

ASSEMBLY INSTRUCTIONS

MAXINE PARSON DINING CHAIR

ASSEMBLY
REQUIREMENTS:

1-Person
Assembly

30 MINUTES
Assembly Time
Per Chair
(Approximate)

Tools Required:
(Not Provided)

Mallet or
Hammer

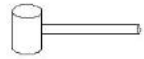

Thank you for purchasing our product!

Please refer and use this assembly instruction to assemble the product.

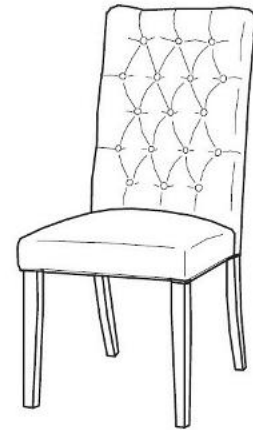

We appreciate your business!

ASSEMBLY PREPARATION

1. Remove all packaging materials, staples and packing straps from the carton.
2. Refer to Parts List and Hardware List and ensure they are complete before you start assembling.
Contact customer service for missing parts.
3. Place all wooden parts on a clean, flat and soft surface (e.g. carpet or rug) to prevent parts from getting scratched.

SAFETY PRECAUTION:

1. KEEP ALL HARDWARE PARTS OUT OF REACH OF CHILDREN.
2. DISPOSE PLASTIC PACKAGING MATERIAL IMMEDIATELY TO AVOID ANY RISK OF SUFFOCATION TO CHILDREN AND ANIMALS.

TIPS FOR ASSEMBLY:

1. Allow ample room for assembly and in close proximity to where product will be placed.
2. Assemble the product on a surface that does not scratch or damage the exterior gloss and finish of the furniture.
3. Identify all of the parts, hardware and quantities required for each step.
4. During assembly, do not over-tighten any fittings as this may cause damage.
5. DO NOT USE POWER TOOLS TO ASSEMBLE THIS PRODUCT.
6. Always place the product on a flat surface.
7. Do not sit or stand on the partially assembled product; only use the product for which it is intended.

CARE AND MAINTENANCE

- Use a slightly damp cloth to clean the product. Do not use bleach or abrasive cleaning material.
- Check all the fittings periodically and re-tighten as necessary. Do not use the product if any of the parts is damaged or broken.
- Never allow any kind of liquid to remain on your furniture. Absorption can cause wood to warp or delaminate.
- Do not place hot items (e.g. hot drinks) directly onto the wood surface.
- Do not drag and/or pull the furniture.

This product is for indoor and household use only - not for commercial use.







ASSEMBLY INSTRUCTIONS

MAXINE PARSON DINING CHAIR

PARTS LIST (FOR 2 COMPLETE CHAIRS)

NO.	COMPONENT	QTY.
P1	CHAIR BACK	2
P2	CHAIR SEAT	2
P3	FRONT LEG	4

HARDWARE LIST (FOR 2 NOS. OF CHAIRS)

NO.	DESCRIPTION	QTY.	EXTRA
H1	JCBC SCREW M6 X 90 	8	1
H2	JCBC SCREW M6 X 60 	8	1
H3	JCBC SCREW M6 X 50 	4	1
H4	SPRING WASHER 	20	2
H5	FLAT WASHER 	20	2
H6	ALLEN KEY 	1	
H7	LEG GLIDES 	8	2

* Extra Hardware For Spare Use

STEP 1

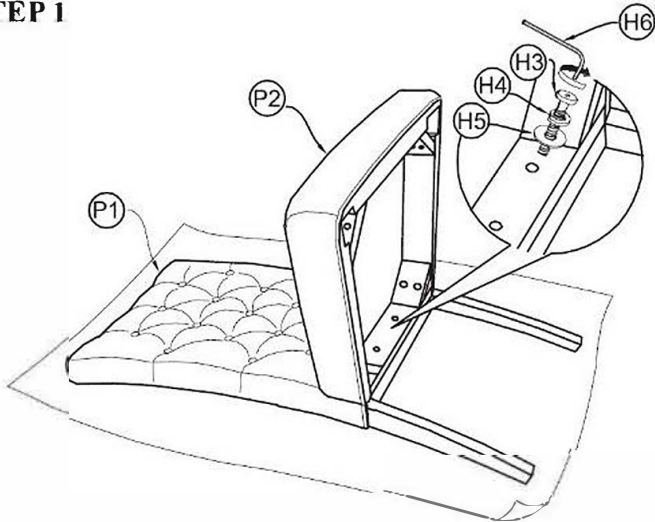

- Lay Chair Back (P1) flat down on a material that does not scratch or damage the part.
- Place Chair Seat (P2) on Chair Back (P1) aligning the middle screw holes on (P2) to screw holes on (P1).
- Use Allen Key (H6) to drive JCBC Screw (H3) fitted with Spring Washer (H4) and Flat Washer (H5) to fasten (P2) to (P1). Do not tighten fully at this time.

STEP 2

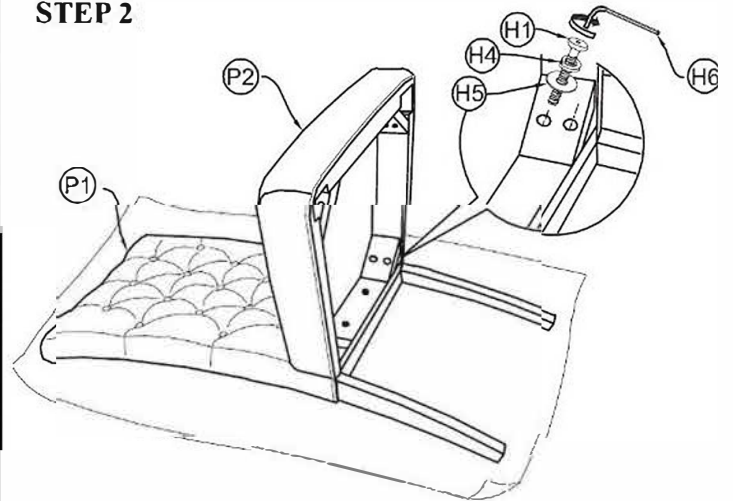

- Use Allen Key (H6) to drive JCBC Screw (H1) fitted with Spring Washer (H4) and Flat Washer (H5) into screw holes on the left and right rear corner blocks of (P2). Do not tighten completely until all 4x (H1) are in place.
- Tighten JCBC Screw (H3) in Step 1 completely.
- Do not over-tighten all of the screws.

STEP 3

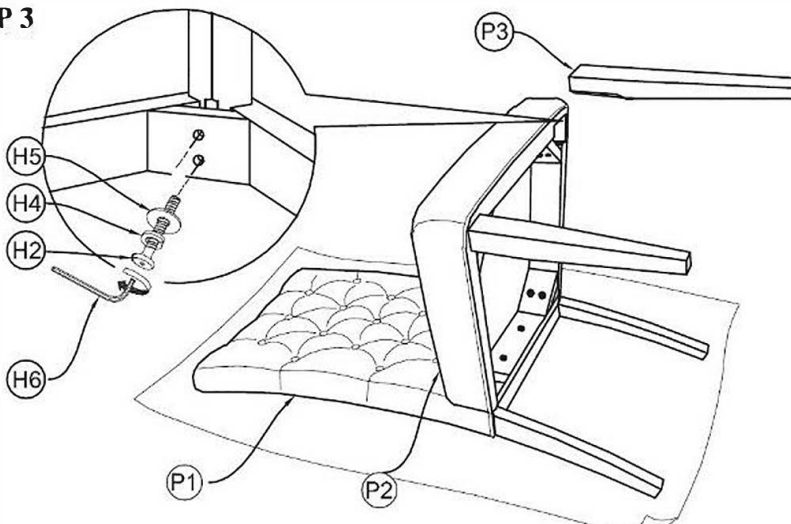

- Insert Front Leg (P3) into the front corners of (P2) as shown, and align the screw holes on (P3) to the screw holes on front corner block.
- Use Allen Key (H6) to drive JCBC Screw (H2) fitted with Spring Washer (H4) and Flat Washer (H5) into screw holes. Do not tighten completely until both screws are in place. Do not over-tighten screws.

STEP 4

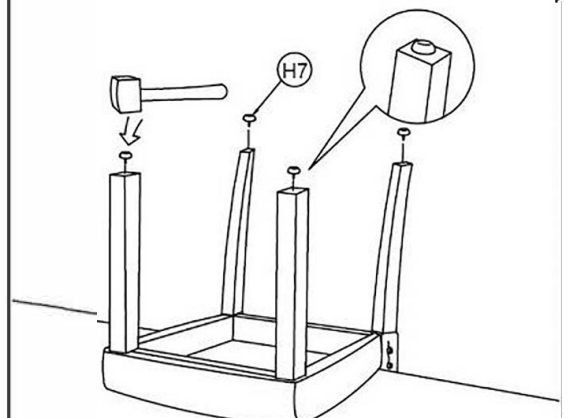

- Place the chair on an elevated surface (e.g. tabletop) as shown.
- Use a mallet or hammer to affix Leg Glide (H7) to each leg.

The assembly of the chair is complete.