

NOTICE

- * Please make sure that you have all parts indicated and they are in good condition before you begin assembly of this item. Refer to part list and hardware list below for guidance.
- * This item should be assembled on a soft surface to prevent scratching the finish during assembly.
- * This item may require periodic tightening.
- * If you are having difficulty, our friendly Customer Care team is always here to help. Please email customersupport@safavieh.com

PREPARATION

- * Before beginning assembly of product, make sure all parts are present. Compare parts with part contents list and hardware contents list.
- * If any part is missing or damaged, do not attempt to assemble the product.
- * Estimated Assembly Time: 15 minutes.
- * Tools Required for Assembly (included): Allen Key.

CARE AND MAINTENANCE

INDOOR METAL/ALUMINUM FURNITURE: Wipe spills immediately. Maintain with regular dusting and clean with mild soap and water, dry thoroughly and do not use a brass cleaner. Adhesive felt pads should always be used/applied in order to prevent damage to the furniture or surfaces on which the furniture is placed.

UPHOLSTERY CARE: To prevent overall soiling, frequent vacuuming or light brushing is recommended. Cushions and pillows should be turned on a weekly basis. Down-filled cushions should be brushed rather than vacuumed. Spot clean, using a mild water-free solvent or dry cleaning product. Only a professional cleaner should undertake a complete overall cleaning. The use of steam or water-based cleaners may cause excessive shrinking or staining.

SAFAVIEH FURNITURE

Model# DCH6400-SET2

Product Dimensions: 20.5"W x 20.25"D x 32"H

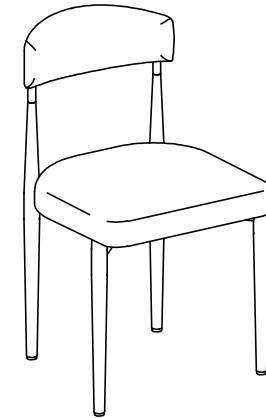











Weight capacity: 275 lbs

WARNING : DO NOT STAND ON THE PRODUCT

WARNING : DO NOT OVER TORQUE BOLTS

Part List and Hardware List

PIECE	DESCRIPTION	PICTURE	QTY
A	Backrest		1x
B	Seat Cushion		1x
C	Upper Leg Frame		1x
D	Lower Leg Frame		1x
E	Connecting Bar		1x

PIECE	DESCRIPTION	PICTURE	QTY
HW1	Hex Socket Bolt 1/4"-20 x 0.6"		2x
HW2	Hex Socket Bolt 1/4"-20 x 1.6"		4x
HW3	Bolt M4 x 0.16"		2x
HW4	Allen Key M2		1x
HW5	Allen Key M4		1x

PREPARATION

- * Before beginning assembly of product, make sure all parts are present. Compare parts with part contents list and hardware contents list.
- * If any part is missing or damaged, do not attempt to assemble the product.
- * Estimated Assembly Time: 15 minutes.
- * Tools Required for Assembly (included): Allen Key.
- * If you are having difficulty, our friendly Customer Care team is always here to help. Please email customersupport@safavieh.com

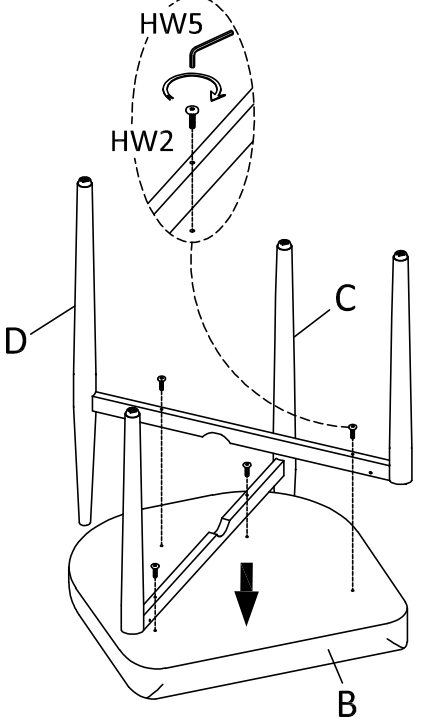
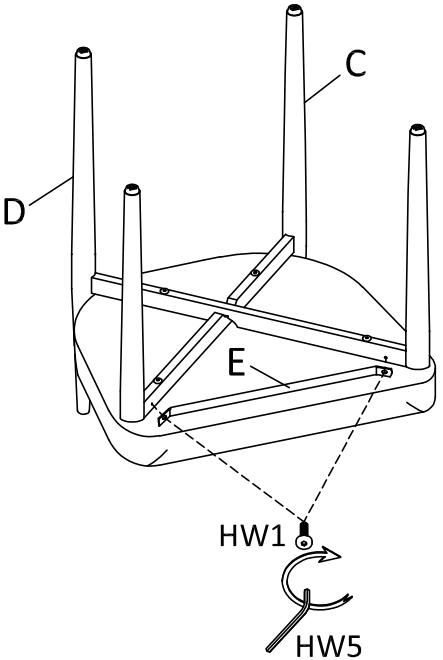
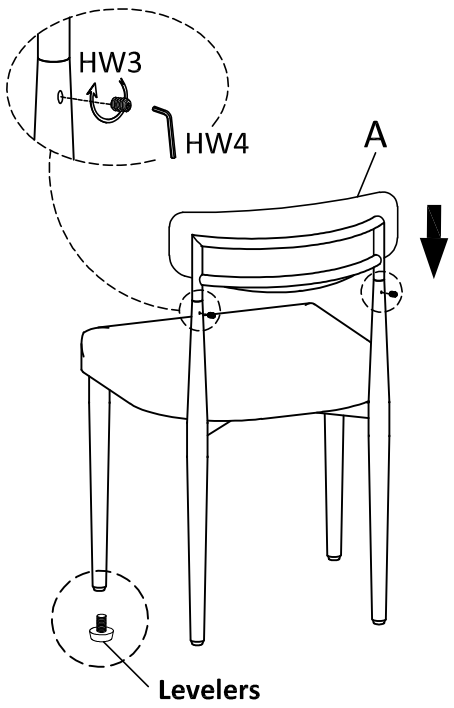
<p>1</p>  <p>*Do not fully tighten the bolts until the product is assembled.</p>	<p>2</p>  <p>*Do not fully tighten the bolts until the product is assembled.</p>	<p>3</p>  <p>*After properly adjusting the levelers for stability, then fully tighten all bolts.</p>
<p>Step 1 Place the Seat Cushion (B) upside down on a clean, soft surface. Align the screw holes on the Seat Cushion (B) to the screw holes on of Upper / Lower Leg Frame (C & D). Attach them by using the Allen Key (HW5) to screw in the Hex Socket Bolt (HW2).</p>	<p>Step 2 Place the Connecting Bar (E) in the front of the assembled Leg Frames. Attach the Connecting Bar (E) to the Leg Frames by using the Allen key (HW5) to screw in the Hex Socket Bolt (HW1).</p>	<p>Step 3 Place the product upright. Insert the Backrest (A) onto the back leg, Attach them by using the Allen Key (HW4) to screw in 2x Bolts (HW3).</p>