

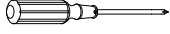

ASSEMBLY INSTRUCTIONS

ASSEMBLY REQUIREMENTS	1.5 Hours Assembly Time (Approximate)	2 -Person Assembly 	Tools Required (Not Provided): Phillips Screwdriver  ⊕ Flat Head Screwdriver  ⊖
-----------------------	---	---	---

Thank you for purchasing our product!

Please refer and use this assembly instruction to assemble the product.
Contact our customer service department in case there are any missing or damage parts or hardware.
Replacement parts are normally shipped within 2 or 3 days.

PRODUCTS PURCHASED THROUGH OUR AUTHORIZED VENDORS ONLY ARE ELIGIBLE FOR REPLACEMENT PARTS.

THIS PRODUCT IS FOR INDOOR AND HOUSEHOLD USE ONLY - NOT FOR COMMERCIAL USE.

ASSEMBLY PREPARATION

1. Remove all packaging materials, staples and packing straps from the carton.
2. Refer to Parts List and Hardware List and ensure they are correct before assembly.
Contact customer service for missing parts.
3. Place all wooden parts on a clean, flat and soft surface (e.g. carpet or rug) to prevent parts from getting scratched.

SAFETY PRECAUTION:

1. KEEP ALL HARDWARE PARTS OUT OF REACH OF CHILDREN.
2. DISPOSE PLASTIC PACKAGING MATERIAL IMMEDIATELY TO AVOID ANY RISK OF SUFFOCATION TO CHILDREN AND ANIMALS.

TIPS FOR ASSEMBLY:

1. Allow ample room for assembly and in close proximity to where product will be placed.
2. Assemble the product on a surface that does not scratch or damage the exterior gloss and finish of the furniture.
3. Identify all of the parts, hardware and quantities required for each step.
4. During assembly, do not over-tighten any fittings as this may cause damage.
5. DO NOT USE POWER TOOLS TO ASSEMBLE THIS PRODUCT.
6. Always place the product on a flat, level surface.
7. Do not sit or stand on the partially assembled product; only use the product for which it is intended.







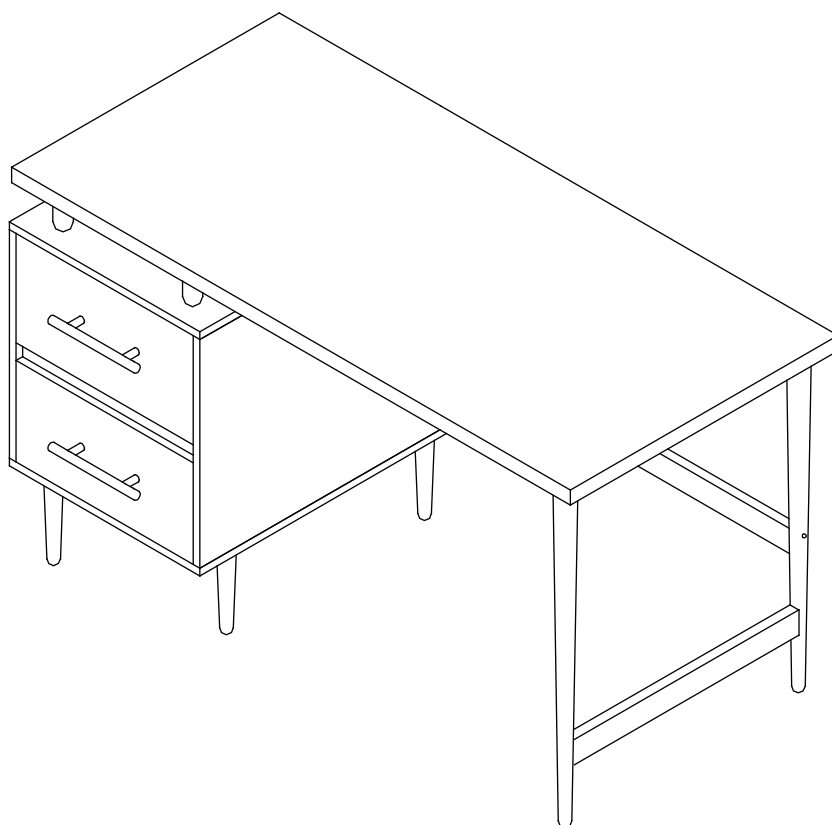









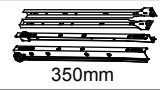

CARE AND MAINTENANCE

1. Wipe clean with a soft, dry cloth; avoid the use of harsh chemicals or household cleaners as they may damage the exterior finish of the furniture.
2. Hardware may loosen over time. Periodically, check that all connections are tight; re-tighten as necessary.
3. Solid wood is impacted by heat and humidity fluctuations which may cause small joint separations or hairline cracks; place the furniture away from direct sunlight and air conditioning vents, heating vents or units to protect the furniture.

ASSEMBLY INSTRUCTIONS











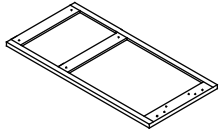
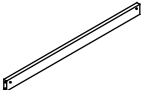

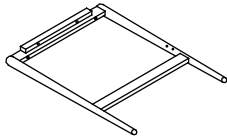
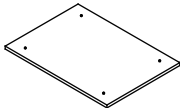

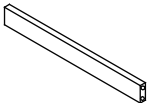
Hardware List

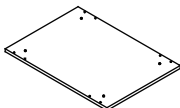
ITEM	DESCRIPTION	PART	QTY	ITEM	DESCRIPTION	PART	QTY
A	Cam-Bolt	 6*35mm	14 pcs	J	Bolt	 6*45mm	2 pcs
B	Cam-Lock	 15*10mm	14 pcs	K	Barrel Nut		2 pcs
C	Wood Dowel	 8*30mm	14 pcs	L	Bolt	 8*35mm	4 pcs
D	Drawer Glide	 350mm	2 sets	M	Lock Nut		4 pcs
E	Screw	 3*12mm	24 pcs	N	Flat Washer		4 pcs
F	Screw	 4*30mm	8 pcs	O	Screw	 7*40mm	8 pcs
G	Handle Bolt	 4*16mm	4 pcs	P	Screw	 2.5*10mm	12 pcs
H	Handle		2 pcs	Q	Allen Wrench	 6mm	1 pc
I	Wrench		1 pc	R	Allen Wrench	 8mm	1 pc

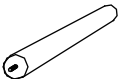
ASSEMBLY INSTRUCTIONS

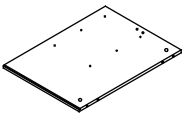
Parts List

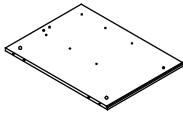
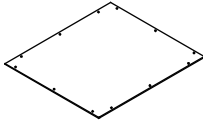
ITEM	DESCRIPTION	PART	QTY	ITEM	DESCRIPTION	PART	QTY
1	Top Panel		1 pc	9	Connect Bar		1 pc
2	Spacer		4 pcs	10	Right Frame		1 pc
3	Cabinet Top Panel		1 pc	11	Drawer Front Panel		2 pcs
4	Connect Bar		1 pc	12	Drawer Back Panel		2 pcs
5	Cabinet Bottom Panel		1 pc	13	Drawer Left Panel		2 pcs
6	Leg		4 pcs	14	Drawer Right Panel		2 pcs
7	Cabinet Left Panel		1 pc	15	Drawer Bottom Panel		2 pcs
8	Cabinet Right Panel		1 pc	16	Back Panel		1 pc

ASSEMBLY INSTRUCTIONS

ASSEMBLY OVERVIEW

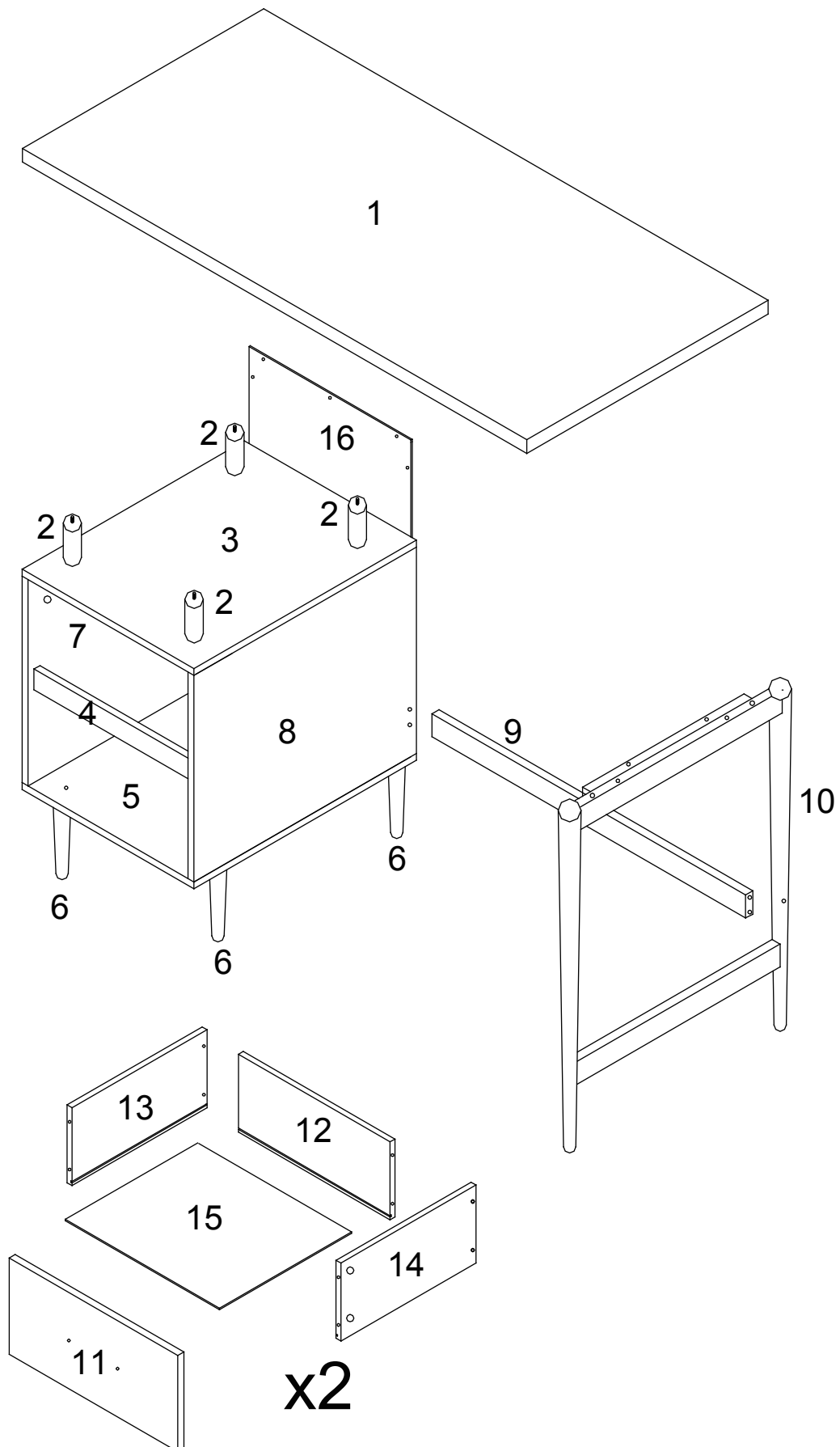

Instructions For Fastening CAM-BOLT and CAM-LOCK



CAM-BOLT



CAM-LOCK

INSERTING AND TIGHTENING CAM-BOLT

Insert Cam-bolt into the pre-drilled hole. Use a Phillips Screwdriver to tighten until shoulder is snug and flushed with panel. See illustrations below.

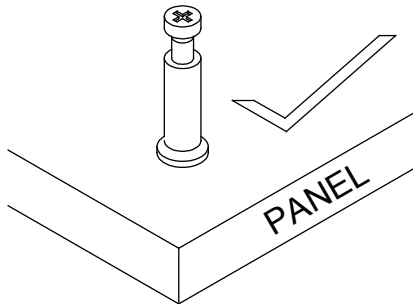
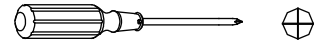

Shoulder is flushed (on the same level) with the panel.

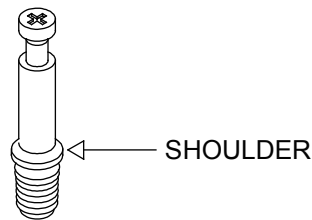

SHOULDER

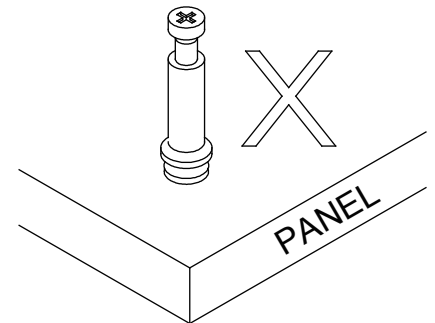

Shoulder is above the panel.

INSERTING CAM-LOCK

Align the arrow on the Cam-lock to the Cam-bolt head and insert the Cam-lock.

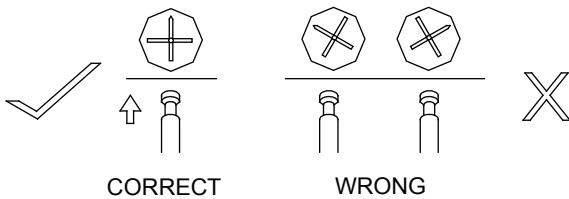

CORRECT

WRONG

TIGHTENING CAM-LOCK

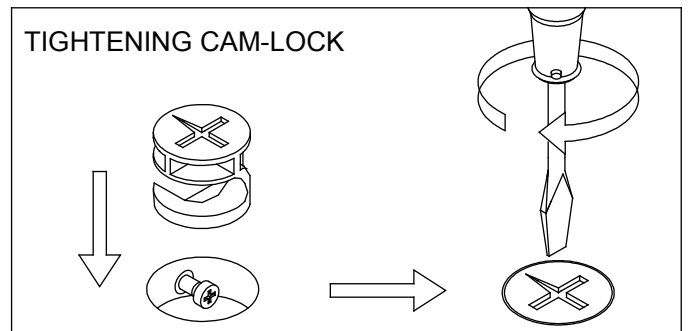

Use a Flat-head Screwdriver to turn Cam-lock clockwise so it locks onto the head of the Cam-bolt. Turn until it is snug (about one half of a turn) -- over-tightening could damage Cam-lock or/and Cam-bolt.

Instructions for installing Barrel Nut

Insert Barrel Nut with the perpendicular hole facing and in-line with the drill hole that the bolt is to be inserted.

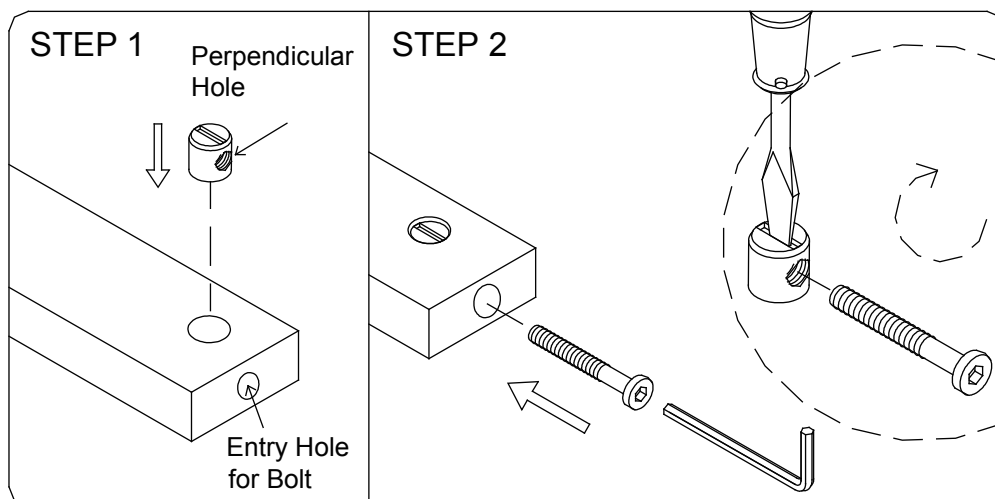

Use a Flat-head Screwdriver to hold Barrel Nut in position before inserting bolt to thread into the Barrel Nut.

STEP 1

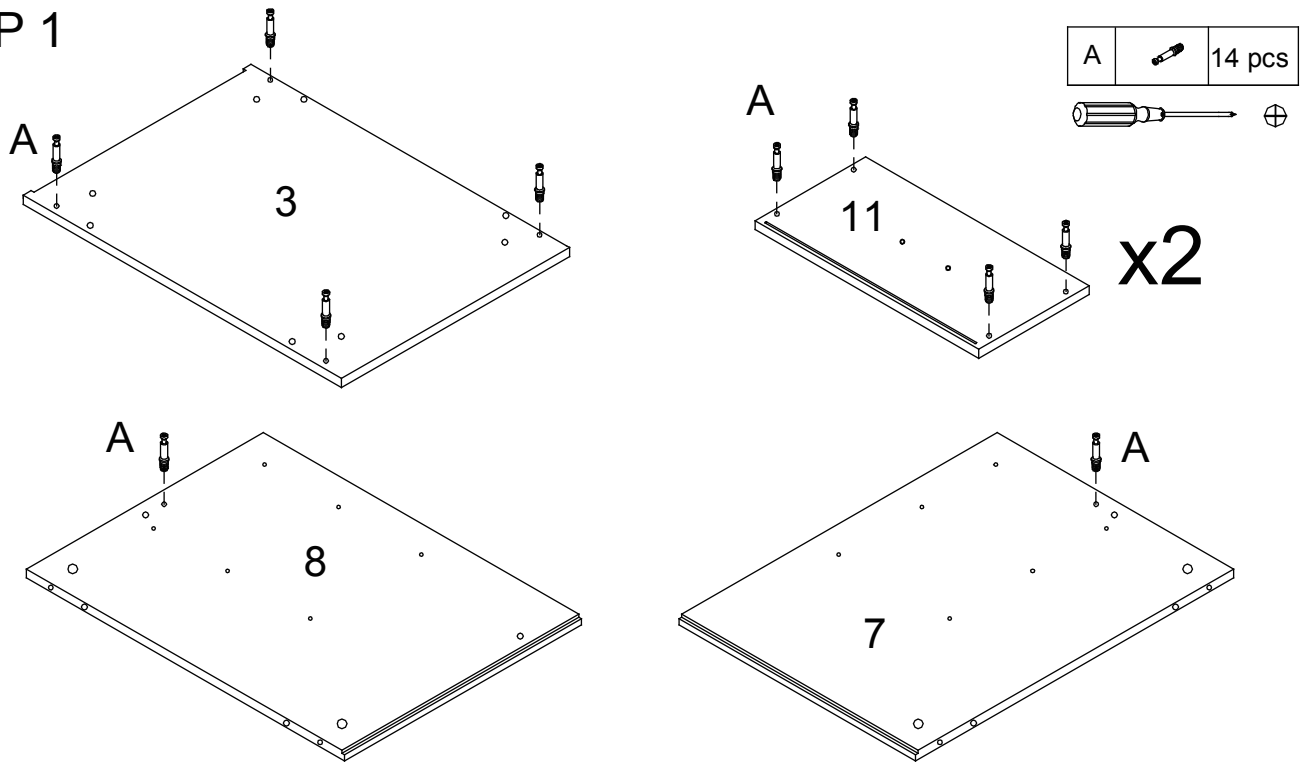

- Lay Cabinet Top Panel (3), Cabinet Left Side Panel (7), Cabinet Right Side Panel (8) and Drawer Front Panel (11) as shown on a material that does not scratch the surface of each part.
- Screw in Cam-bolt (A) into the designated holes on each part. Refer to Page 5 for instructions on inserting and tightening Cam-bolt.

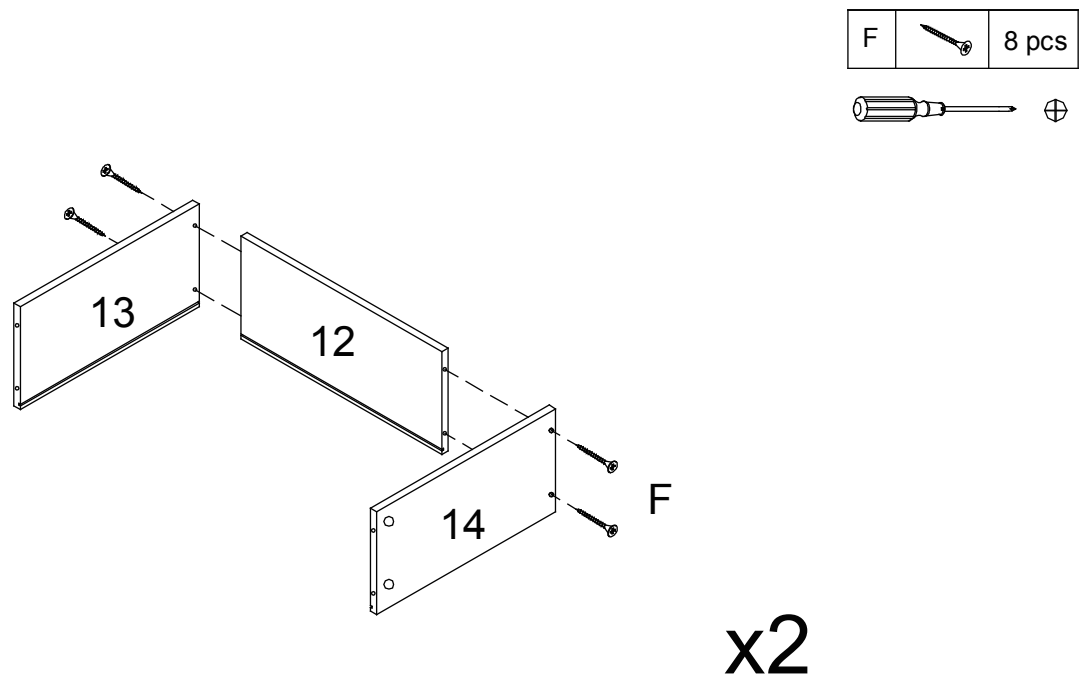

STEP 2

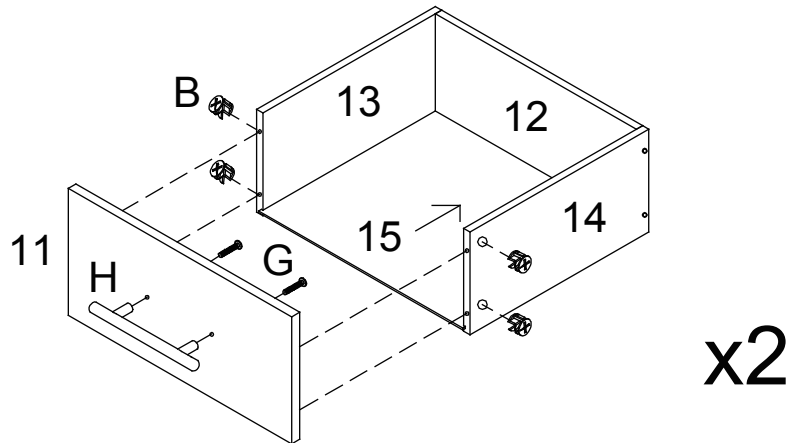

- Position Drawer Back Panel (12) between Drawer Left & Right Panels (13 & 14) as shown. Note: the groove on each panel has to be aligned.
- Use Screw (F) to fasten side panels to back panel. Do not tighten screws completely until both screws are in each Side Panel.

STEP 3



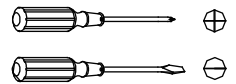

B		8 pcs
G		4 pcs
H		2 pcs

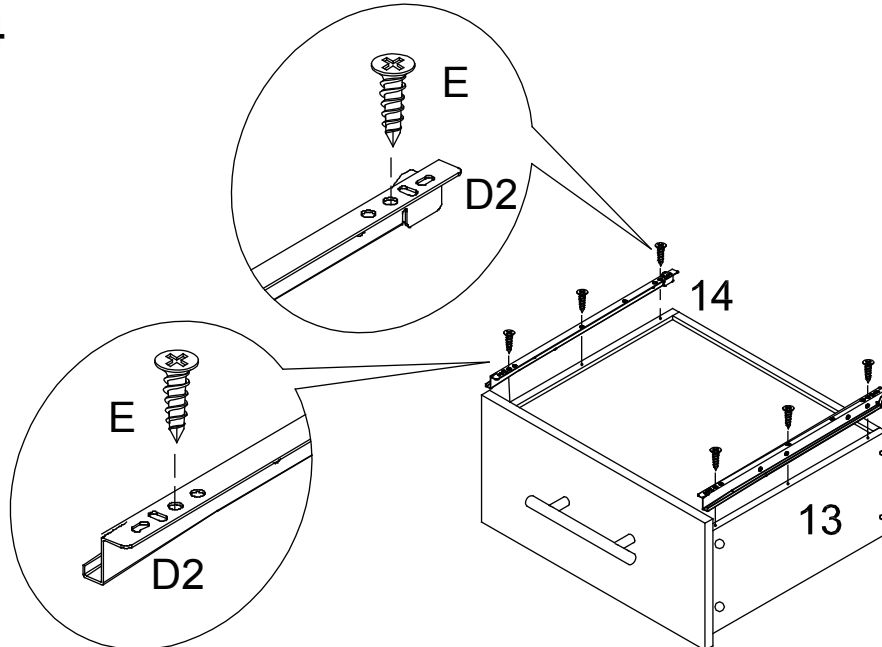

- Fit Drawer Bottom Panel (15) to Drawer Panel (13 & 14) via groove on respective drawer panels. Check that the back edge of (15) also fits into the groove on the Drawer Back Panel (12).
- Attach Drawer Front Panel (11) to Side Panels (13 & 14) firmly via cam-bolts on (11). Check that front edge of Bottom Panel (15) fit into the groove on the inside-face of Front Panel (11).
- Insert Cam-lock (B) into the holes on (13 & 14) then turn clockwise to lock onto Cam-bolt on (11). Refer to Page 5 for instructions on inserting and tightening cam-lock.
- Use Handle Bolt (G) to fasten Handle (H) to (11).

STEP 4



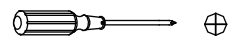

D2		4 pcs
E		12 pcs



- Position Drawer Slide Runner (D2) against the drawer side panels as shown (note: the roller on (D2) is towards the back panel of the drawer) and identify the designated screw holes on (D2) - refer to enlarged drawings.
- Use Screw (E) to fasten (D2) to Side Panels (13 & 14). Use a Phillips screwdriver to drive (E). Do not tighten (E) completely until all 3 screws are in place.

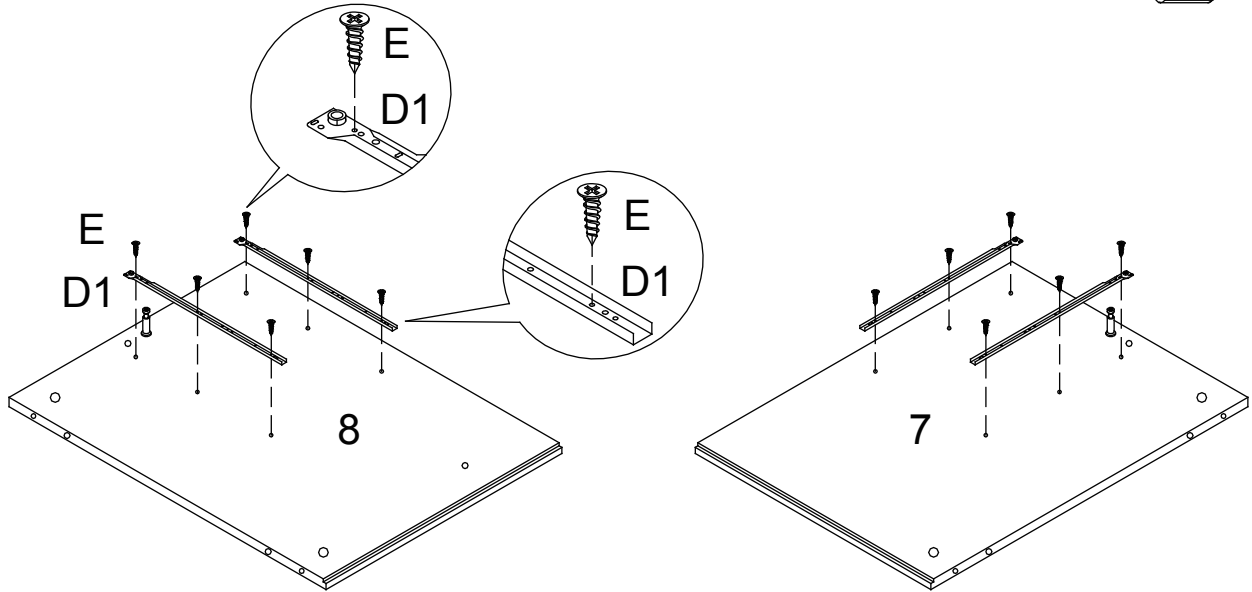
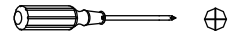

STEP 5

D1		4 pcs
E		12 pcs



- Place Drawer Slide Track (D1) to align the designated screw holes on (D1) to pilot holes on Cabinet Left Panel (7) and Cabinet Right Panel (8) - Refer to enlarged drawings.
- Use Screw (E) to fasten (D1) to (7 & 8). Do not tighten (E) completely until all 3 screws are in place.

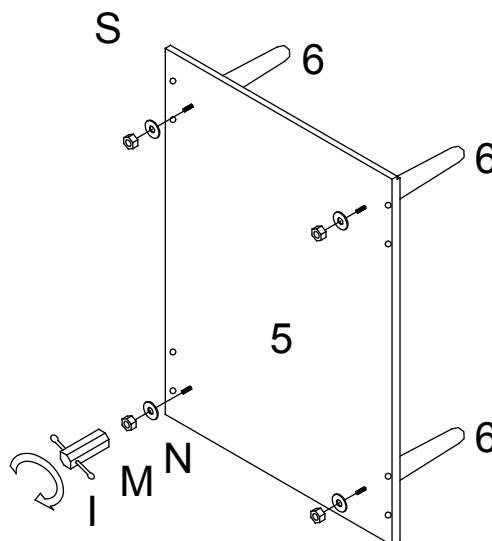

STEP 6

I		1 pc
M		4 pcs
N		4 pcs



- Position the bolt on Leg (6) through the hole on Cabinet Bottom Panel (5) as shown.
- Fit Flat Washer (N) to the bolt and screw the Lock Nut (M) in clockwise direction.
- Use Wrench (I) to tighten (M).

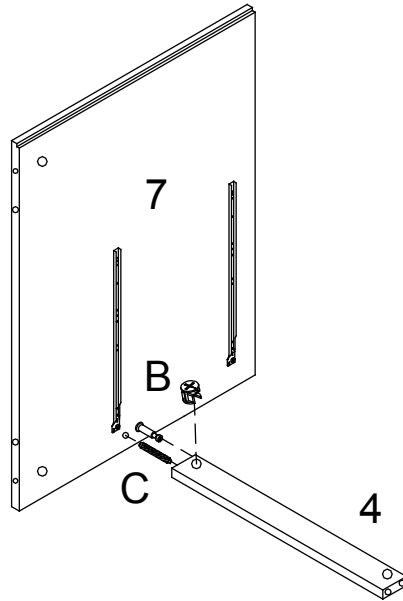
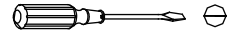

STEP 7

B		1 pc
C		1 pc



- Insert Wood Dowel (C) to Connect Bar (4) as shown.
- Attach Connect Bar (4) to Cabinet Left Side Panel (7) via Cam-bolts on (7) and Wood dowel.
- Insert Cam-lock (B) into the holes on (4) then turn clockwise to lock onto Cam-bolt.

STEP 8

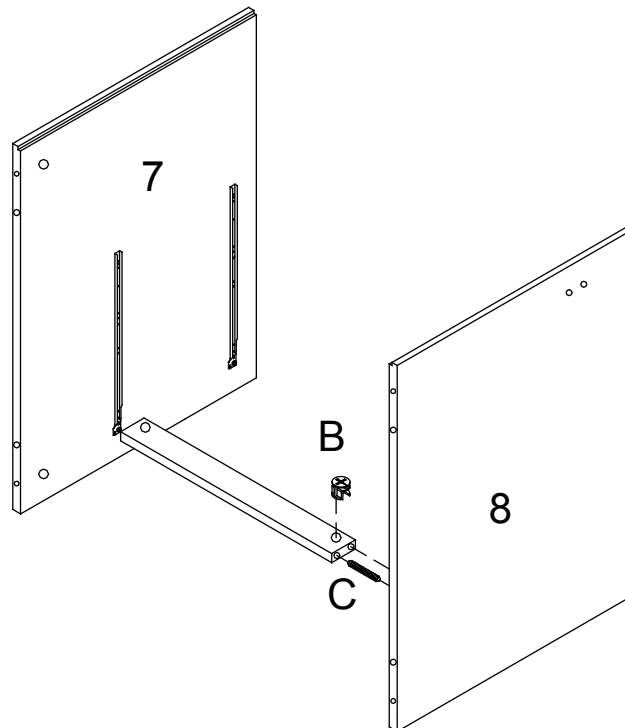

B		1 pc
C		1 pc

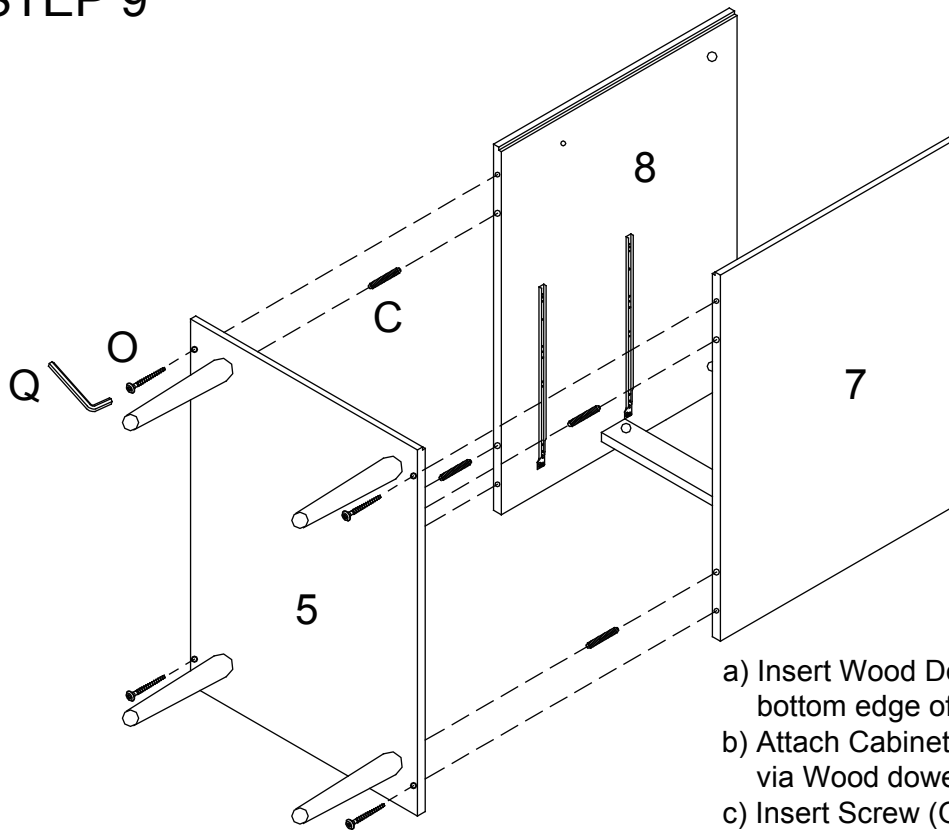

- Insert Wood Dowel (C) to Connect Bar (4) as shown.
- Attach Cabinet Right Side Panel (8) to Connect Bar (4) via Cam-bolts on (8) and Wood dowel.
- Insert Cam-lock (B) into the holes on (4) then turn clockwise to lock onto Cam-bolt.

STEP 9





C		4 pcs
O		4 pcs
Q		1 pc

- Insert Wood Dowel (C) to both inner holes on bottom edge of Cabinet Side Panel (7 & 8).
- Attach Cabinet Bottom Panel (5) to (7 & 8) via Wood dowel.
- Insert Screw (O) through the screw holes on (5) to thread into screw holes on (7 & 8).
- Tighten the Screw (O) using Allen Wrench (Q). Do not tighten screw completely until all 4 screws are in place.

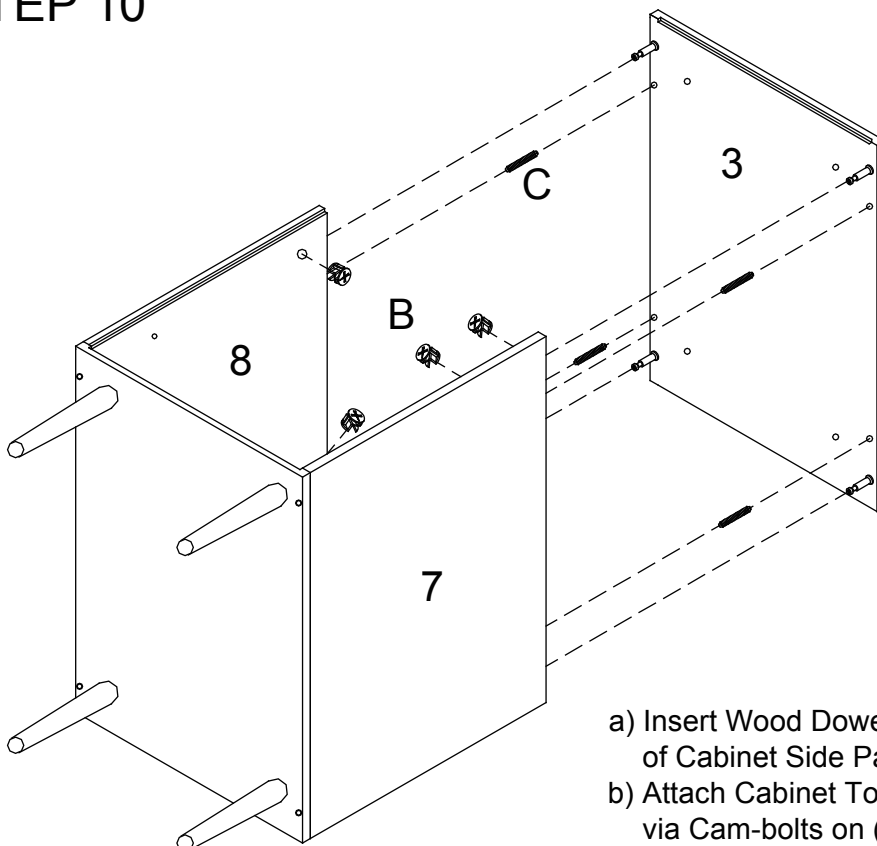
STEP 10



B		4 pcs
C		4 pcs

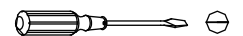

- Insert Wood Dowel (C) to both inner holes on top edge of Cabinet Side Panel (7 & 8).
- Attach Cabinet Top Panel (3) to Side Panels (7 & 8) via Cam-bolts on (3) and Wood dowel.
- Insert Cam-lock (B) into the holes on (7 & 8) then turn clockwise to lock onto Cam-bolt on (3).
- With assistance set the assembly right-side up.

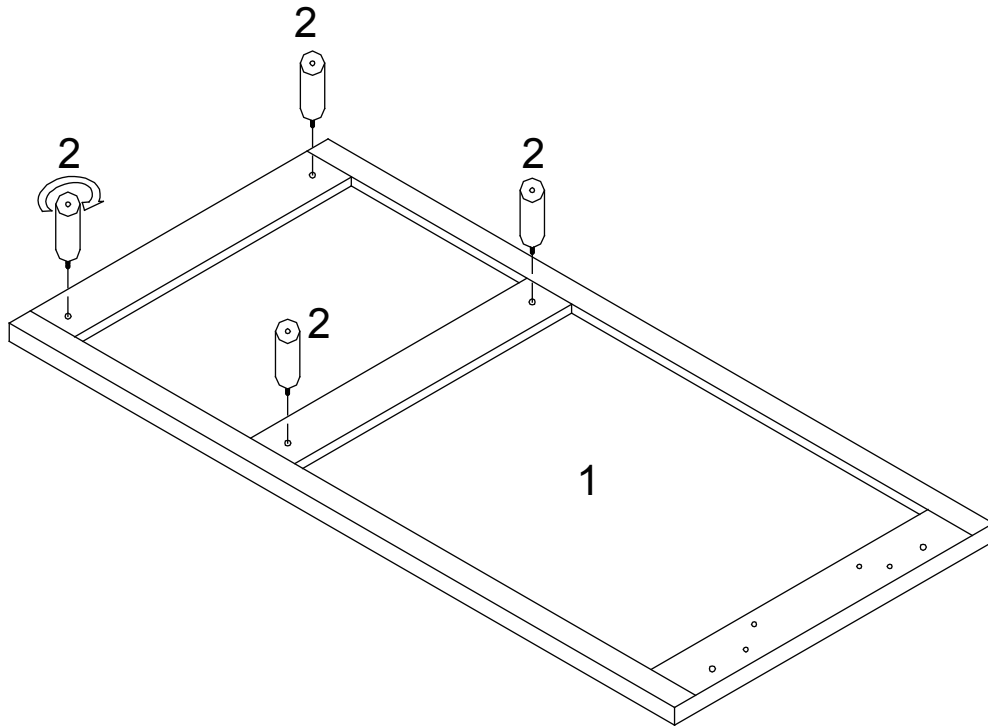

STEP 11



- Lay Top Panel (1) bottom-side up flat on a material that does not scratch or damage the part.
- Screw in Spacer (2) into the designated holes on the bottom-side of (1) in clockwise direction.

STEP 12

- Insert Wood Dowel (C) into the designated holes on Top Panel (1).
- Attach Right Frame (10) to (1) via Wood Dowels.
- Insert Bolt (L) through the bolt hole on connect bar and tighten with Allen Wrench (R).

C		2 pcs
L		4 pcs
R		1 pc

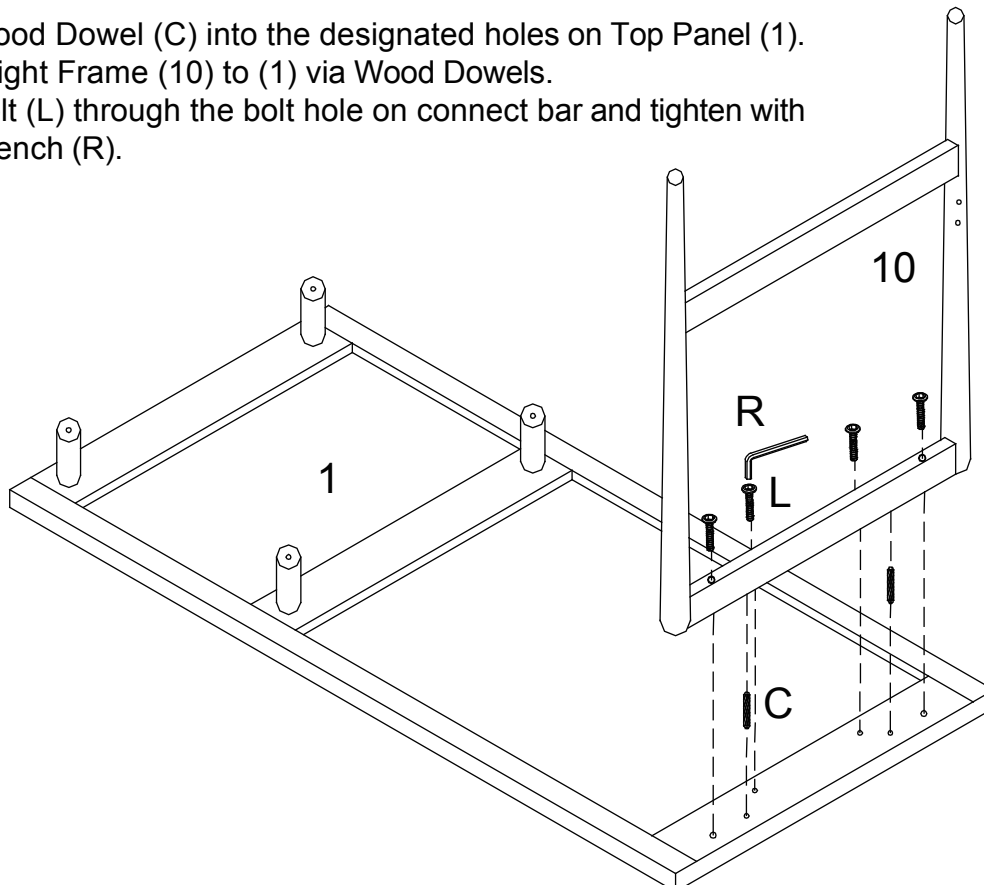

STEP 13

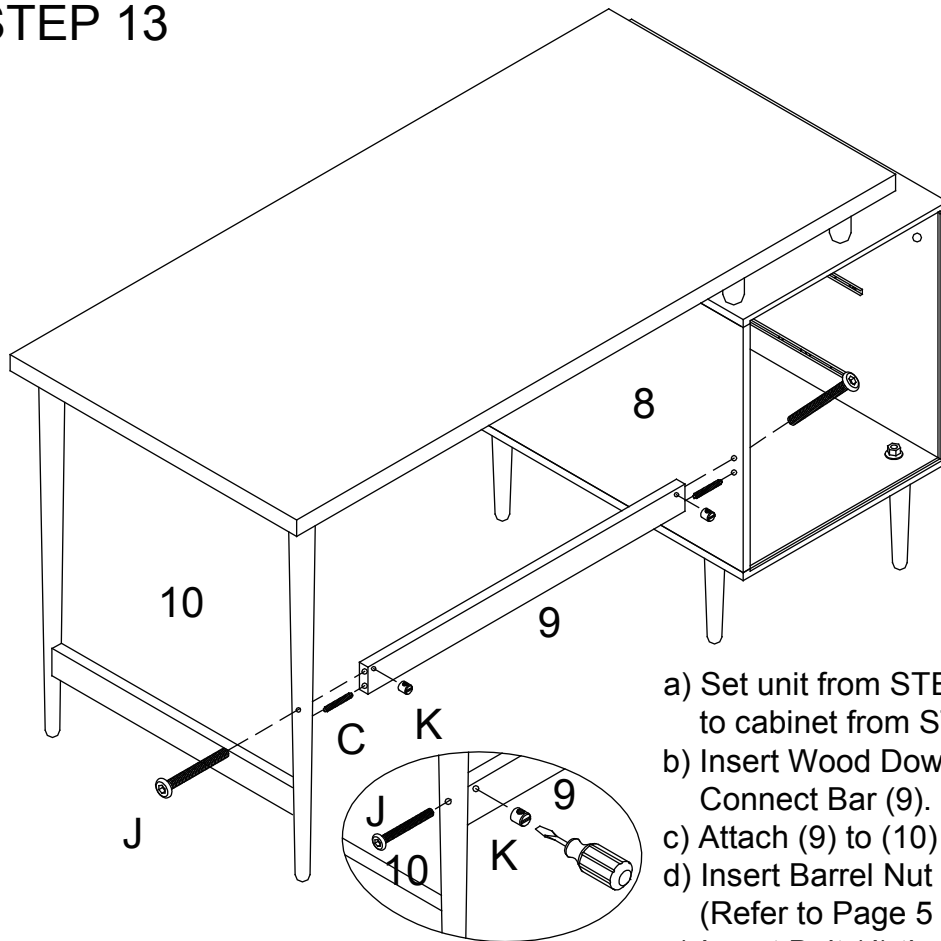

C		2 pcs
J		2 pcs
K		2 pcs

- Set unit from STEP 12 right-side up and attach to cabinet from STEP 10.
- Insert Wood Dowel (C) into designated hole on Connect Bar (9).
- Attach (9) to (10) and (8) via Wood Dowels.
- Insert Barrel Nut (K) to designated hole on (9) (Refer to Page 5 for Barrel Nut instructions)
- Insert Bolt (J) through the bolt hole on (8 & 10) to thread into Barrel Nut. Do not tighten the bolts.

STEP 14

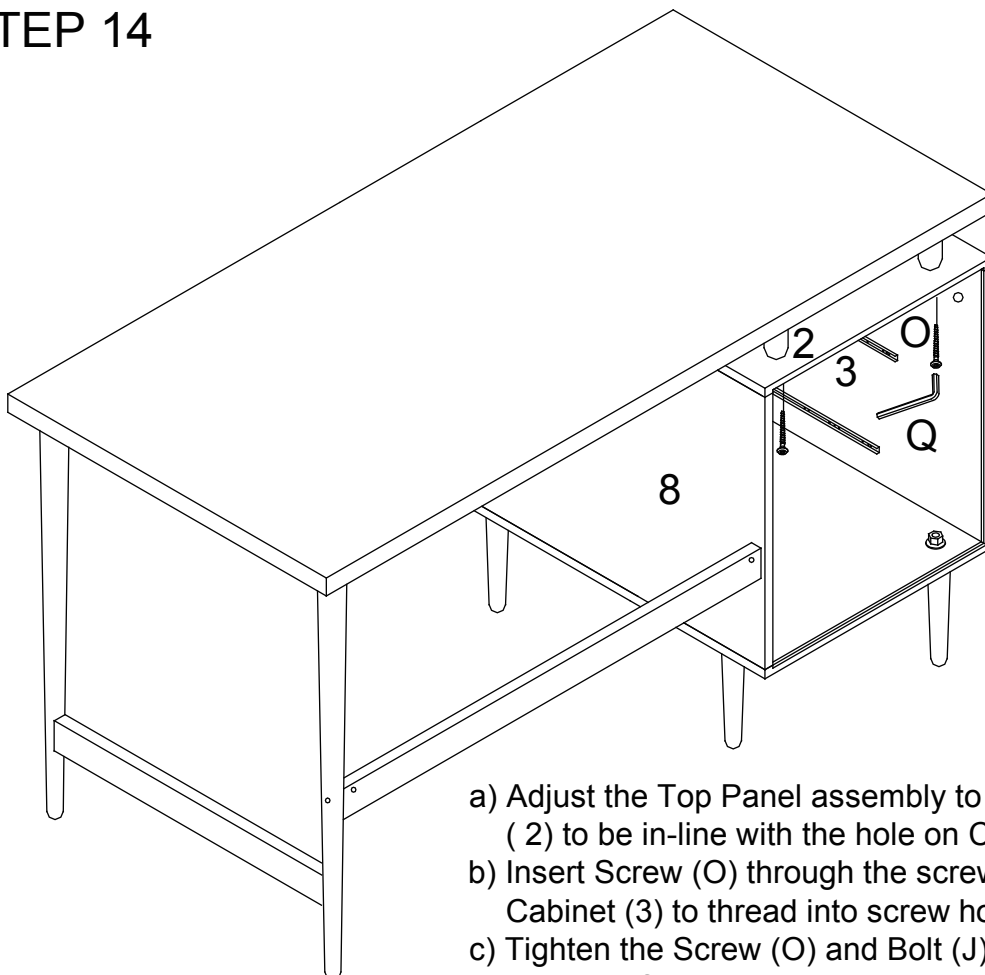

O		4 pcs
Q		1 pc

- Adjust the Top Panel assembly to position the hole on Spacer (2) to be in-line with the hole on Cabinet Top Panel (3).
- Insert Screw (O) through the screw holes on Top Panel of Cabinet (3) to thread into screw holes on (2).
- Tighten the Screw (O) and Bolt (J) from STEP 13 using Allen Wrench (Q). Do not tighten the screws completely until all 4 screws are in place.

STEP 15

P		12 pcs
---	---	--------

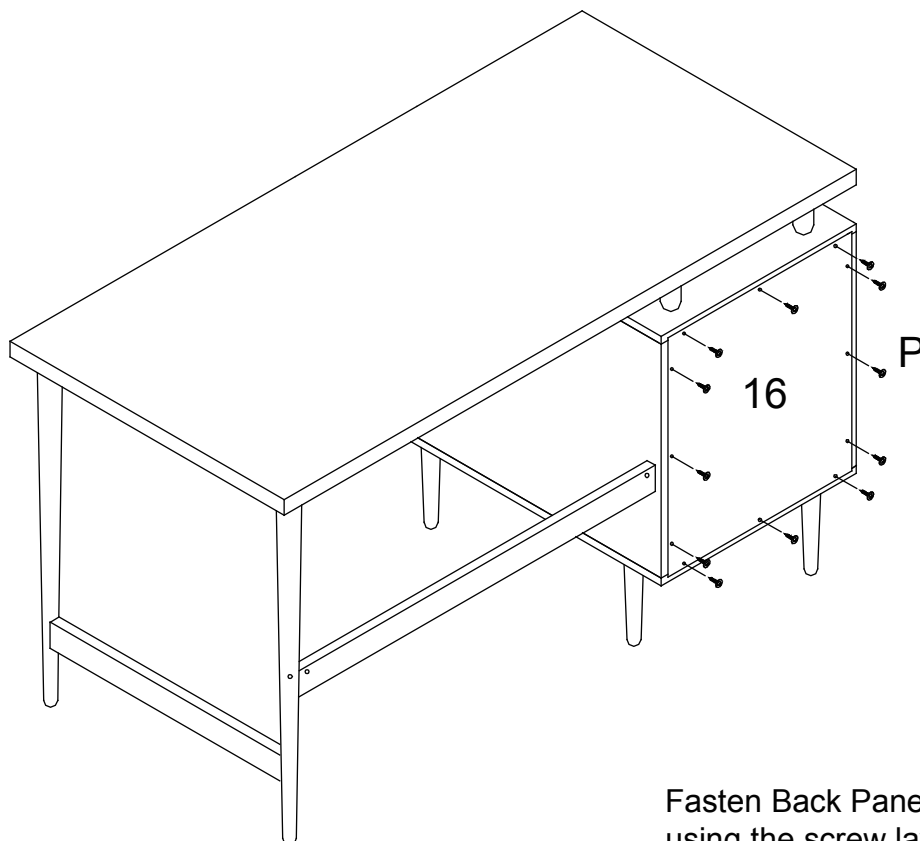
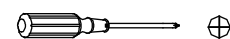

Fasten Back Panel (16) with Screw (P) using the screw layout as shown.

STEP 16

Insert Drawer as shown.

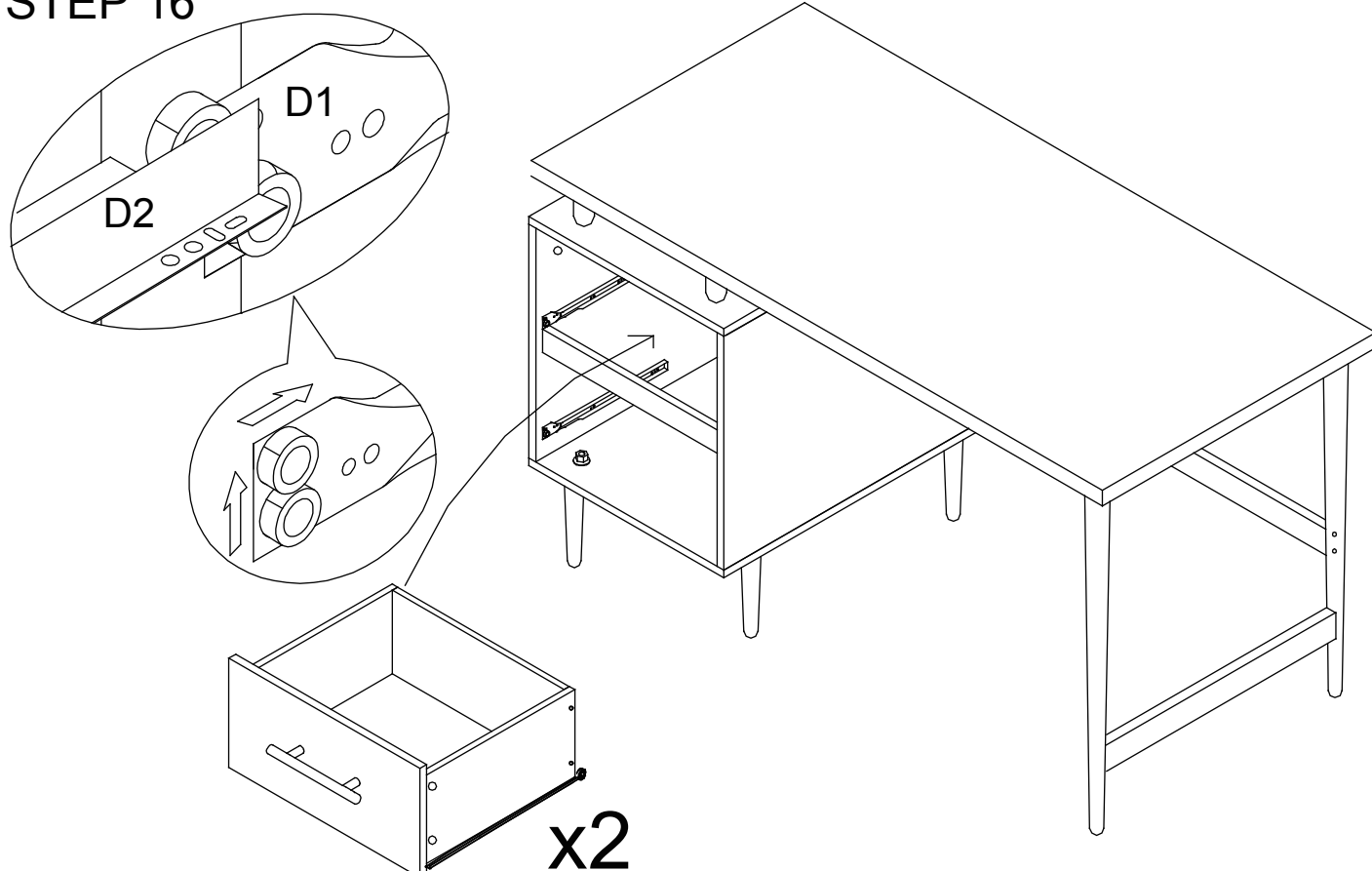

- Align roller on Drawer Slide Runner (D2) on drawer to be above the roller on Drawer Slide Track (D1) on Left/Right & Divide Panel, and slide roller on (D2) into track rail on (D1).
- Push drawer squarely and gently to allow (D2) to slide into (D1).

The assembly of the desk unit is complete.