

ASSEMBLY INSTRUCTIONS



086-925

TOOLS REQUIRED:

Allen Wrench (Provided, Part E)

BEFORE YOU START:

1. Check the hardware against the hardware list to make sure all items are present.
2. Assemble your furniture on a soft, flat surface to avoid scratching the finish.
3. **CAUTION:** Do not over tighten screws, nuts or bolts during assembly.
4. Your furniture may require occasional tightening.

INSTRUCTIONS:

Step 1. Turn the top upside down on a clean soft surface. Attach top stretcher to support legs and tighten Bolt (B) with Flat Washer (D)+Lock Washer (C) by Allen Wrench (E) as Figure 1 shown.

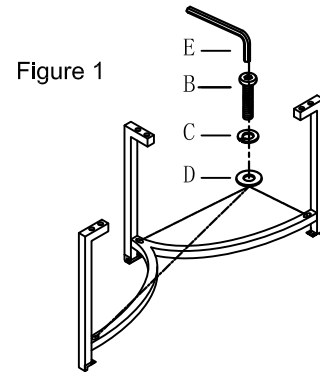

Figure 1

Step 2. Place bottom shelf to support legs and tighten Bolt (B) with Flat Washer (D)+Lock Washer (C) by Allen Wrench (E). Attach L Shape Metal Bracket (F) to center legs and tighten Bolt (A) with Flat Washer (D)+Lock Washer (C) by Allen Wrench (E) as Figure 2 shown.

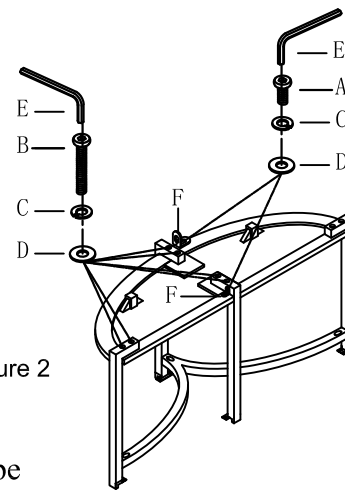

Figure 2

Step 3. Place the table to top round frame to make sure holes on metal cap is aligned with holes on top round frame. Tighten Bolt (A) with Flat Washer (D)+Lock Washer (C) by Allen Wrench (E) as Figure 3 shown.

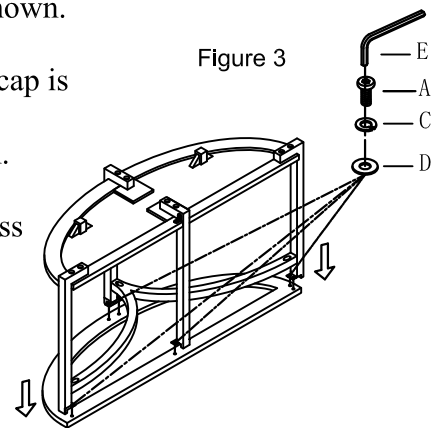

Figure 3

Step 4. Tighten all bolts before setting table back upright. Place the glass on top of the top frame as Figure 3 shown.

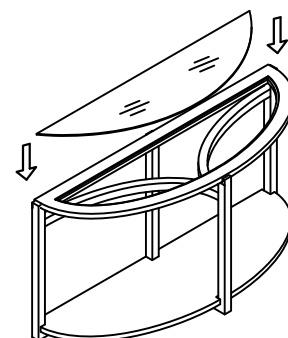







Figure 4

HARDWARE LIST			
A		Bolt (Ø1/4"x3/4")	12pcs
B		Long Bolt (Ø1/4"x1-3/4")	11pcs
C		Lock Washer (Ø1/4")	23pcs
D		Flat Washer (Ø1/4")	23pcs
E		Allen Wrench (Φ1/4"*60*25mm)	1pc
F		L Shape Metal Bracket(32*32*20mm)	2pcs