

N130P375216/N130P375217

Product manual
Gebrauchsanweisung
Manuel du produit
Manual del producto
Manuale del prodotto

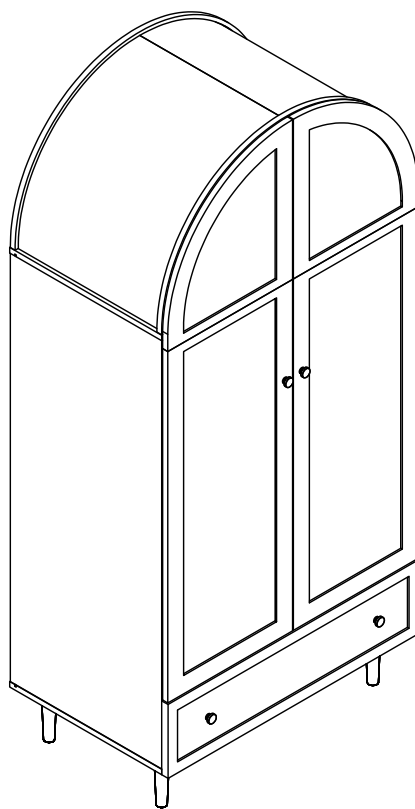

EN:Our product will be delivered to you in 2 packages. The delivery times of these 2 packages may differ, please be patient and thank you for your understanding

DE:Unsere Produkte teilen sich in zwei Pakete auf. Die Lieferung der beiden Pakete kann je nach Jahreszeit variieren, so warten Sie bitte geduldig und danken Sie für Ihr Verständnis

FR:Notre produit vous sera livré en 2 paquets. Les délais de livraison de ces 2 colis peuvent différer, soyez patient et merci de votre compréhension

ES:Nuestro producto le será entregado en 2 paquetes. Los tiempos de entrega de estos 2 paquetes pueden variar, por favor sea paciente y gracias por su comprensión

IT:Il nostro prodotto sarà consegnato in 2 confezioni. I tempi di consegna di questi 2 pacchetti possono variare, per favore siate pazienti e vi ringrazio per la vostra comprensione

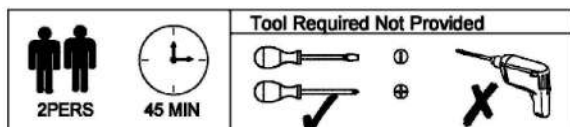



[DE]

Warnung: Lesen Sie die Anleitung vor dem Zusammenbau bitte vollständig durch. Überprüfen Sie, ob Sie alle auf den Seiten aufgeführten Komponenten und Werkzeuge haben.

Warnung: Legen Sie alle Teile auf eine ebene Fläche. Legen Sie eine weiche Decke oder Ähnliches darunter, um sie vor Kratzern oder Flecken zu schützen. Vermeiden Sie es, Komponenten über den Boden zu ziehen oder zu schieben.

Warnung: Überprüfen Sie regelmäßig alle Beschläge und Befestigungen, um sicherzustellen, dass sie sicher sind und um Unfälle zu vermeiden. Wenn Teile fehlen, kaputt, beschädigt oder abgenutzt sind, verwenden Sie das Produkt nicht weiter, bis es mit vom Hersteller autorisierten Teilen repariert wurde.

Warnung: Lassen Sie Kinder nicht auf die Möbel klettern, da dies zum Umkippen und zu schweren Verletzungen führen kann. Bauen Sie die Möbel außerhalb der Reichweite von Kindern zusammen.

Warnung: Stellen Sie die Möbel nicht in die Nähe von Feuerquellen oder heißen Gegenständen, um Brandgefahr zu vermeiden.

Warnung: Reinigen Sie die Möbel mit einem feuchten Tuch oder Alkohol. Verwenden Sie keine Reinigungsmittel mit ätzenden Chemikalien.

Warnung: Dieses Produkt ist mit einer Kippschutzvorrichtung ausgestattet. Bitte installieren Sie diese Vorrichtung unbedingt, um unnötige Verletzungen durch Umkippen zu vermeiden.

[EN]

Warning: Please read instructions fully before starting assembly. Check you have all the components and tools listed on pages.

Warning: Please place all parts on a flat surface. Place a soft blanket or similar underneath to protect against scratches or stains. Avoid dragging or sliding components across the floor.

Warning: Regularly check all fittings and fastenings to ensure they are secure and to prevent accidents. If any parts are missing, broken, damaged, or worn, discontinue use of the product until repairs have been made using factory authorized parts.

Warning: Do not allow children to climb on the furniture as this may result in tipping and serious personal injury. Assemble the furniture away from the reach of children.

Warning: Do not place furniture close to fire sources or high-temperature objects to avoid the risk of fire.

Warning: Clean furniture with a damp cloth or alcohol, avoid using cleaning agents containing corrosive chemicals.

Warning: This product is equipped with an anti-tilt device. Please be sure to install this device to prevent unnecessary injuries caused by tipping.

[FR]

Avertissement : Veuillez lire entièrement les instructions avant de commencer l'assemblage. Vérifiez que vous disposez de tous les composants et outils répertoriés sur les pages.

Avertissement : Veuillez placer toutes les pièces sur une surface plane. Placez une couverture douce ou similaire en dessous pour les protéger des rayures ou des taches. Évitez de faire glisser les composants sur le sol.

Avertissement : Vérifiez régulièrement tous les raccords et fixations pour vous assurer qu'ils sont bien fixés et pour éviter les accidents. Si des pièces manquent, sont cassées, endommagées ou usées, cessez d'utiliser le produit jusqu'à ce que des réparations aient été effectuées à l'aide de pièces autorisées par l'usine.

Avertissement : Ne laissez pas les enfants grimper sur les meubles car cela pourrait entraîner un basculement et des blessures graves. Assemblez les meubles hors de portée des enfants.

Avertissement : Ne placez pas les meubles à proximité de sources de feu ou d'objets à haute température pour éviter tout risque d'incendie.



Avertissement : Nettoyez les meubles avec un chiffon humide ou de l'alcool, évitez d'utiliser des produits de nettoyage contenant des produits chimiques corrosifs.

Avertissement : Ce produit est équipé d'un dispositif anti-basculement. Assurez-vous d'installer ce dispositif pour éviter les blessures inutiles causées par un basculement.

[IT]

Attenzione: leggere attentamente le istruzioni prima di iniziare il montaggio. Verificare di avere tutti i componenti e gli strumenti elencati nelle pagine.

Attenzione: posizionare tutte le parti su una superficie piana. Posizionare una coperta morbida o simile sotto per proteggere da graffi o macchie. Evitare di trascinare o far scivolare i componenti sul pavimento.

Attenzione: controllare regolarmente tutti i raccordi e i dispositivi di fissaggio per assicurarsi che siano sicuri e per prevenire incidenti. Se alcune parti sono mancanti, rotte, danneggiate o usurate, interrompere l'uso del prodotto fino a quando non siano state eseguite le riparazioni utilizzando parti autorizzate dalla fabbrica.

Attenzione: non consentire ai bambini di arrampicarsi sui mobili poiché ciò potrebbe causare ribaltamenti e gravi lesioni personali. Montare i mobili lontano dalla portata dei bambini.

Attenzione: non posizionare i mobili vicino a fonti di fuoco o oggetti ad alta temperatura per evitare il rischio di incendio.

Attenzione: pulire i mobili con un panno umido o alcol, evitare di utilizzare detergenti contenenti sostanze chimiche corrosive.

Attenzione: questo prodotto è dotato di un dispositivo antiribaltamento. Assicurarsi di installare questo dispositivo per prevenire lesioni inutili causate dal ribaltamento.

[ES]

Advertencia: Lea las instrucciones completamente antes de comenzar el montaje. Compruebe que tiene todos los componentes y herramientas que se enumeran en las páginas.

Advertencia: Coloque todas las piezas sobre una superficie plana. Coloque una manta suave o algo similar debajo para protegerlas de rayones o manchas. Evite arrastrar o deslizar los componentes por el piso.

Advertencia: Verifique regularmente todos los accesorios y fijaciones para asegurarse de que estén seguros y evitar accidentes. Si falta alguna pieza, está rota, dañada o desgastada, deje de usar el producto hasta que se hayan realizado las reparaciones con piezas autorizadas de fábrica.

Advertencia: No permita que los niños se suban a los muebles, ya que esto puede provocar que se vuelquen y lesiones personales graves. Monte los muebles fuera del alcance de los niños.

Advertencia: No coloque los muebles cerca de fuentes de fuego u objetos de alta temperatura para evitar el riesgo de incendio.

Advertencia: Limpie los muebles con un paño húmedo o alcohol, evite usar agentes de limpieza que contengan químicos corrosivos.

Advertencia: Este producto está equipado con un dispositivo antivuelco. Asegúrese de instalar este dispositivo para evitar lesiones innecesarias causadas por vuelcos.

Importer	COMHARBOR LIMITED		
Address	Unit C, Swift Point, Cosford Lane, Rugby, CV21 1PY,GB		
Email	harborcomhar@gmail.com		
Manufacturer	ZHANGZHOU SHUJIAN FURNITURE CO.,LTD		
Add	ROOM 101,BUILDING 21,NO.60 BAOXING ROAD, XIANGCHENG DISTRICT,ZHANGZHOU,FUJIAN,CHINA		
Email/URL	Freja_zsj@163.com		
Product identification	N130P375216/N130P375217		
Made in	China		
<table border="1"><tr><td>UK</td><td>REP</td></tr></table>	UK	REP	COMHARBOR LIMITED Unit C, Swift Point, Cosford Lane, Rugby, CV21 1PY,GB harborcomhar@gmail.com
UK	REP		

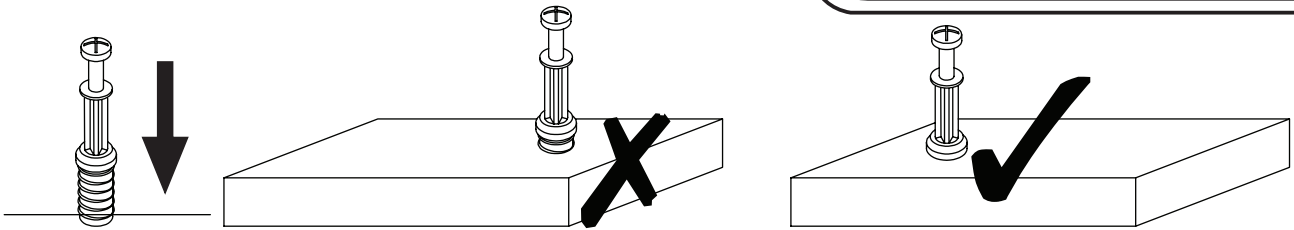

EN_QUICKFIT: Tighten quickfit until shoulder is flush with panel. Do not overtighten or undertighten.

FR_RACCORD RAPIDE: Faites serrer le raccord rapide jusqu'à ce que l'épaulement soit parfaitement encastré dans le panneau. Il ne faut ni trop serrer ni insuffisamment serrer.

ES_QUICKFIT: Apriete quickfit hasta que el hombro se descargue con el panel. NO lo sobreapriete ni lo apriete poco.

DE_QUICKFIT: Ziehen Sie den Quickfit fest, bis die Schulter mit der Platte bündig ist. Bitte nicht zu fest oder zu schwach anziehen.

IT_MONTAGGIO RAPIDO: Stringere il montaggio rapido fino a quando la spalla è a filo con il pannello, non stringere troppo o troppo poco.

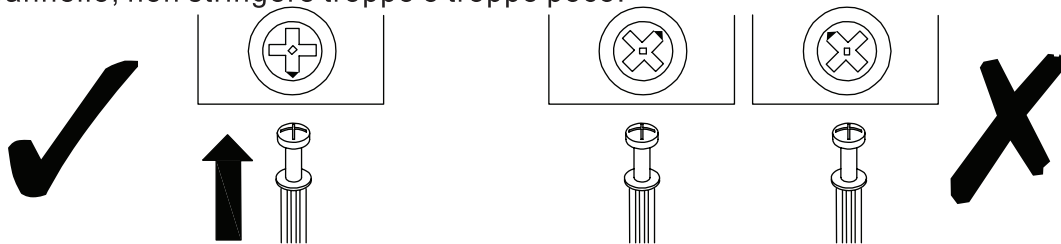

EN_CAM LOCK: When fitting cam lock, ensure starting position is correct before you insert connecting quickfit.

FR_SERRURE BATTEUSE: Avant d'insérer la serrure batteuse, veillez à la bonne orientation avant d'insérer le raccord rapide.

ES_CIERRE DE LA CÁMARA: Cuando instale el cierre de la cámara, asegúrese de que la posición de inicio es correcta antes de que inserte el quickfit conector.

DE_CAM-LOCK: Achten Sie bei der Montage des Cam-Locks auf die richtige Ausgangsposition, bevor Sie den Quickfit einsetzen.

IT_BLOCCAGGIO A CAMMA: Quando si monta il bloccaggio a camma, assicurarsi che la posizione iniziale sia corretta prima di inserire il montaggio rapido di collegamento.

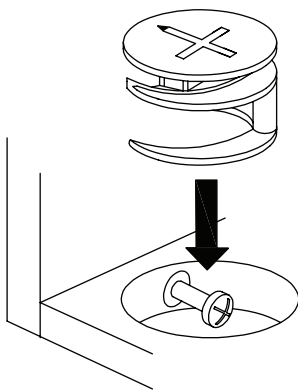

EN_Quickfit head should be in the centre of the cam lock when the two panels are joined.

Cam lock should be inserted before quickfit.

FR_Lorsque les deux panneaux sont assemblés, la tête du raccord rapide doit reposer au centre de la serrure batteuse. Il faut insérer la serrure batteuse avant le raccord rapide.

ES_El cabezal del quickfit debe estar en el centro del cierre de la cámara cuando se unan los dos paneles.

Se debe insertar el cierre de la cámara antes que el quickfit.

DE_Der Quickfit-Kopf sollte sich in der Mitte des Cam-Locks befinden, wenn die beiden Platten zusammengefügt sind. Der Cam-Lock sollte vor dem Quickfit eingesetzt werden.

IT_La testa del montaggio rapido deve trovarsi al centro del bloccaggio a camma quando i due pannelli sono uniti.

Il Bloccaggio a Camma deve essere inserito prima del montaggio rapido.

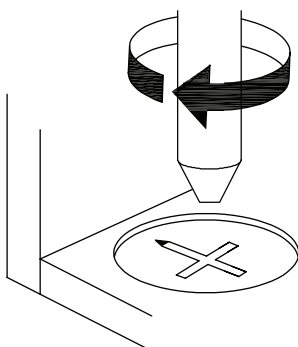

EN_Turn cam lock clockwise to tighten.

FR_Faites tourner la serrure batteuse dans le sens des aiguilles d'une montre pour la resserrer.

ES_Gire el cierre de la cámara en sentido horario para apretarlo.







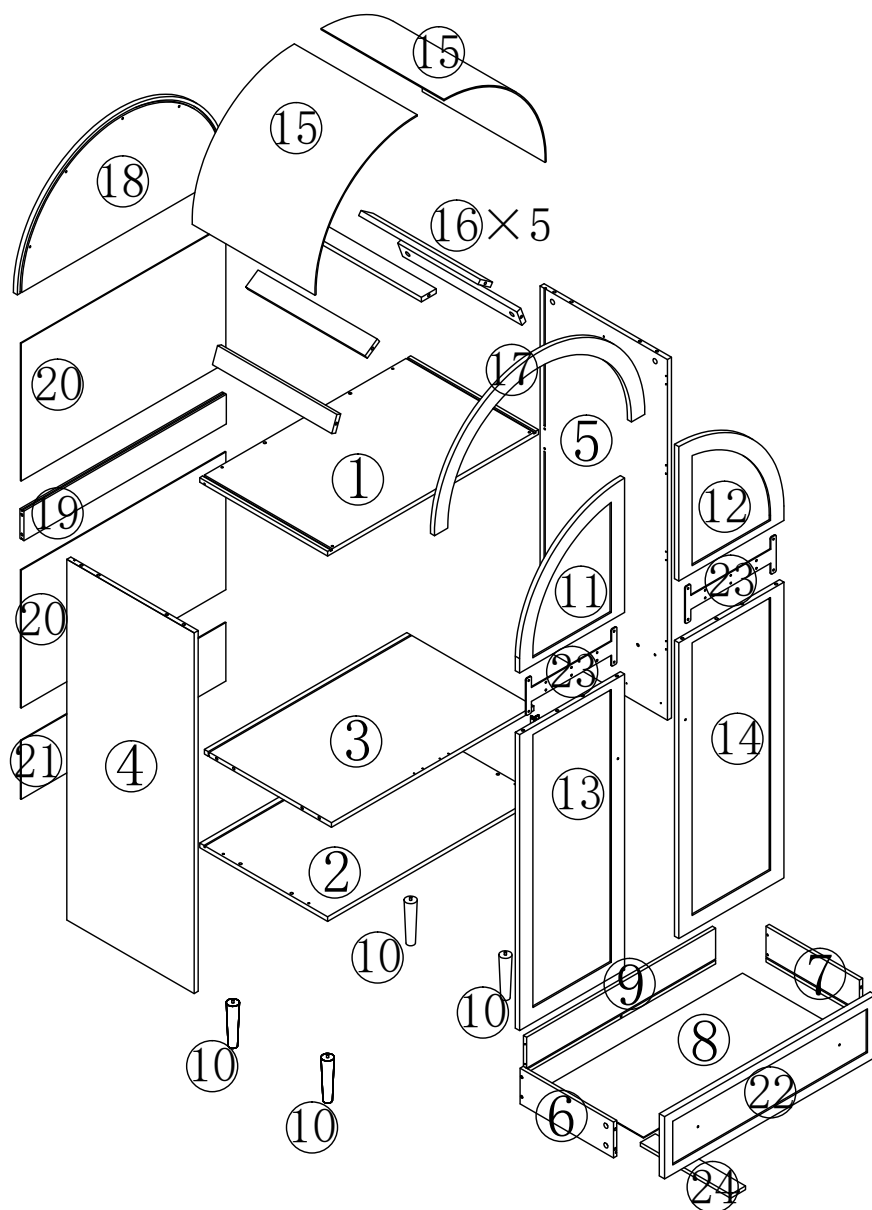

DE_Drehen Sie den Cam-Lock im Uhrzeigersinn, um ihn festzuziehen.

IT_Ruotare il bloccaggio a camma in senso orario per stringere.

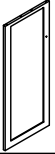

Parts List

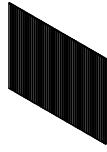





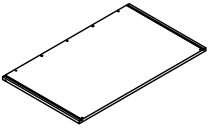
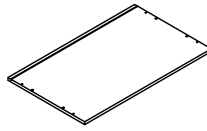
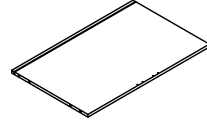
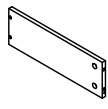
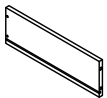
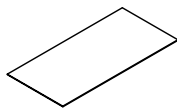
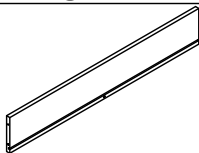

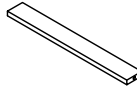
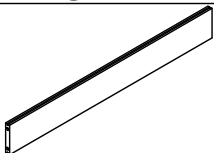
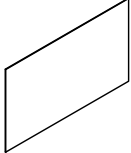
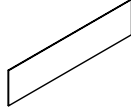
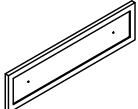
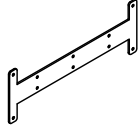
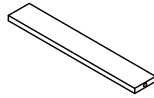



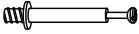

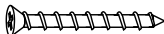

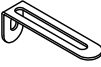



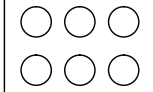
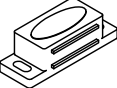

N130P375216

				
④ x1pc	⑤ x1pc	⑪ x1pc	⑫ x1pc	⑬ x1pc
				
⑭ x1pc	⑮ x2pcs	⑰ x1pc	⑱ x1pc	

N130P375217

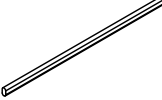
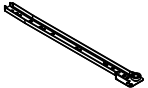
				
① x1pc	② x1pc	③ x1pc	⑥ x1pc	⑦ x1pc
				
⑧ x1pc	⑨ x1pc	⑩ x4pcs	⑯ x5pcs	⑲ x1pc
				
⑳ x2pcs	㉑ x1pc	㉒ x1pc	㉓ x2pcs	㉔ x1pc

Hardware N130P375217

 Ø6x35mm Ⓐx27pcs	 Ø15x9mm Ⓑx27pcs	 Ø8x30mm Ⓒx22pcs	 M4x40mm Ⓓx16pcs	 M3.5x14mm Ⓔx22pcs
 Ⓕx2pcs	 Ⓖx8pcs	 M3.0x14mm Ⓗx94pcs	 Ⓘx16pcs	 Ⓙx2pcs
 Ⓚx1pc	 M4x20mm Ⓛx4pcs	 Ⓜx4pcs	 Ⓝx27pcs	 Ⓞx4pcs
 Ⓟx2pcs	 Ⓠx4pcs	 Ⓡx2pcs	 Ⓢx1pc	
 CL 350mm ⒸⓁx1pc	 CR 350mm ⒸⓇx1pc	 DL 350mm ⒸⓁx1pc	 DR 350mm ⒸⓇx1pc	

	
M3.0x14mm	M3.5x14mm
Hx94pcs	Ex18pcs

DE: Bitte beachten Sie, dass die Formen der Schrauben H und E ähnlich sind. Bitte installieren Sie entsprechend der Anleitung und unterscheiden Sie sie!

EN: Please note that the shapes of screws H and E are similar. Please install according to the instructions and distinguish them!

FR: Notez que les vis H et E ont des formes similaires. Veuillez les installer en suivant les instructions pour les séparer!

IT: Si prega di notare che le forme delle viti H e E sono simili. Si prega di installarle seguendo le istruzioni e di distinguerle!

ES: Por favor, tenga en cuenta que las formas de los tornillos H y E son similares. Por favor, instálelos de acuerdo con las instrucciones y distíngalos.

1

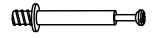



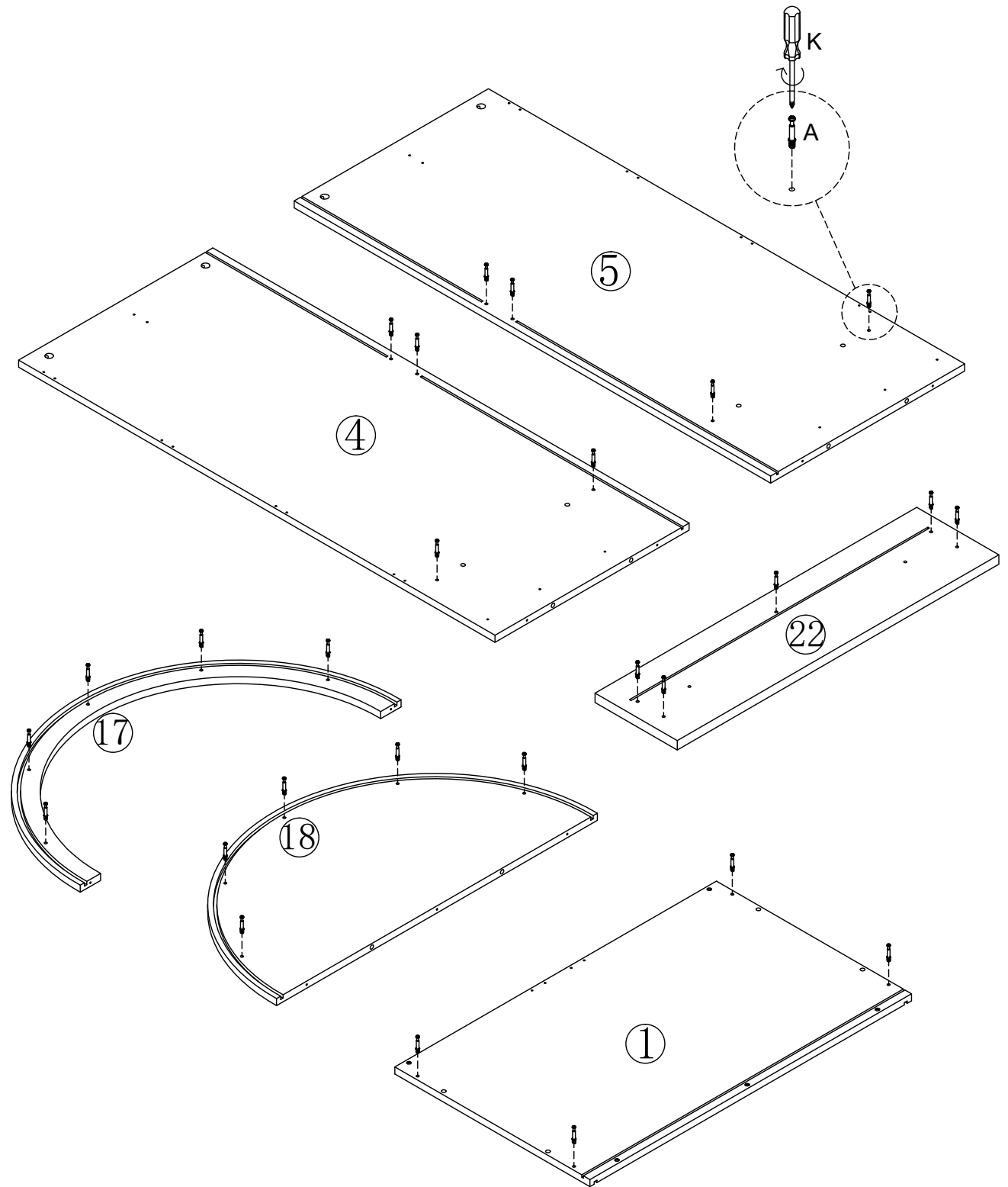

Ø6x35mm

(A)x27pcs



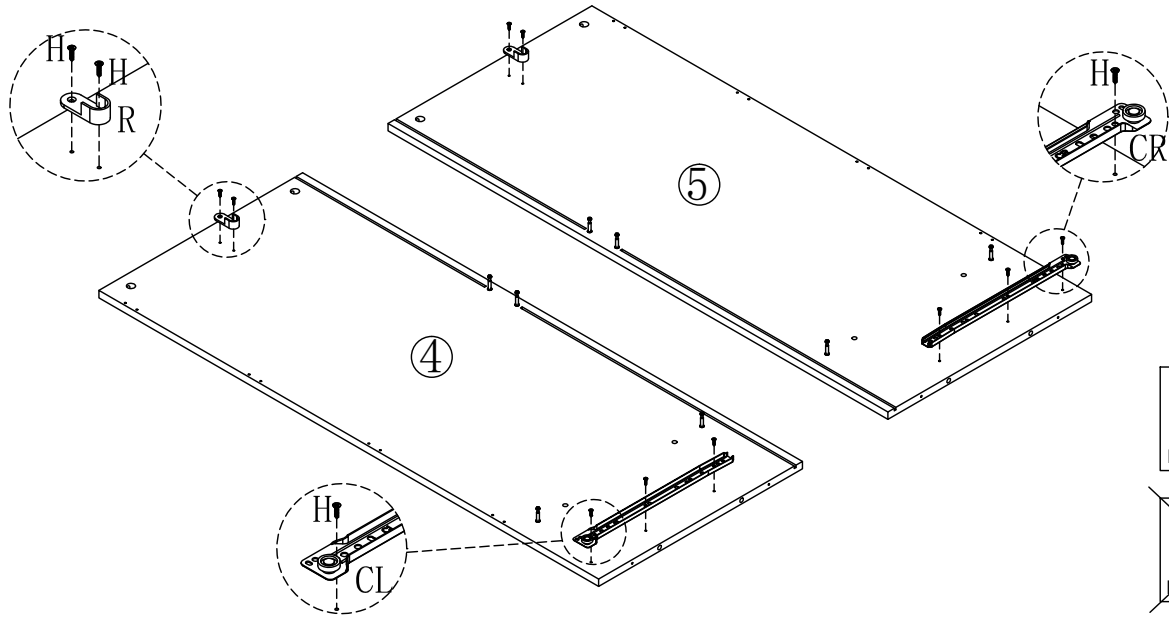
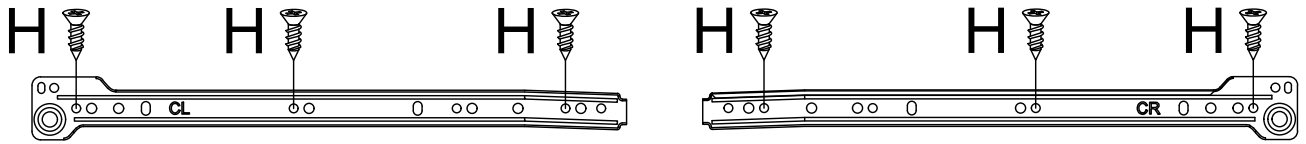

2

 M3.0x14mm Ⓜx10pcs	 R Ⓜx2pcs	 CL 350mm Ⓞx1pc	 CR 350mm Ⓞx1pc
---	--	---	--



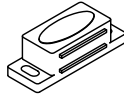

3

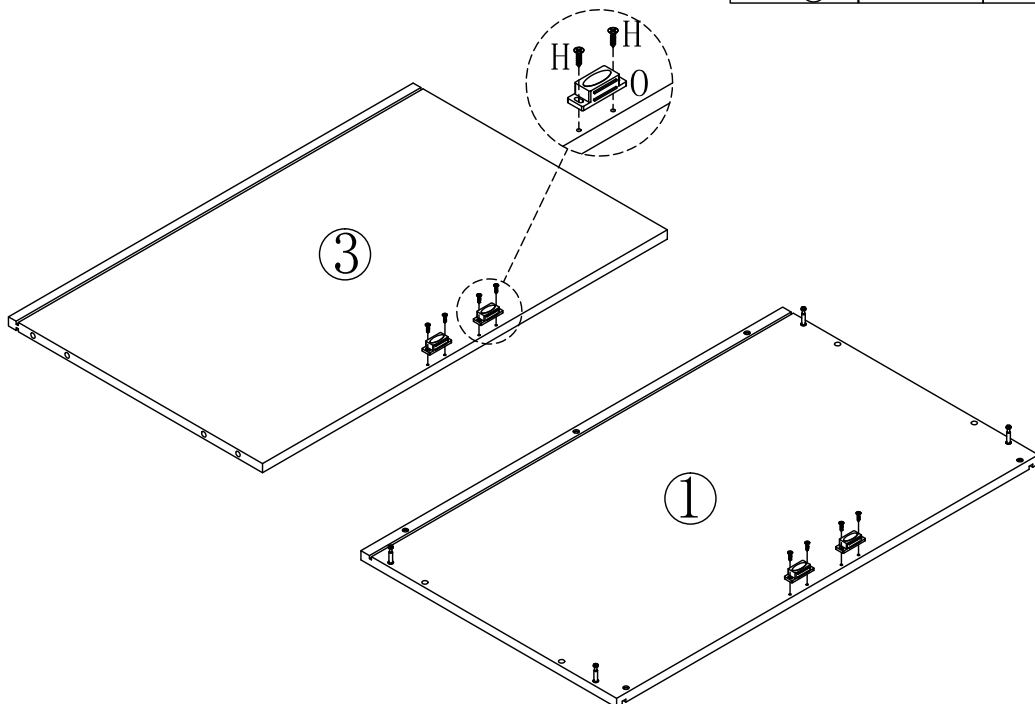
 O Ⓞx4pcs	 M3.0x14mm Ⓜx8pcs
--	--

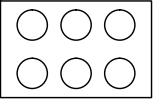

4

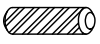
		
Ⓝx4pcs	ⓑx4pcs Ø15x9mm	ⓒx2pcs Ø8x30mm

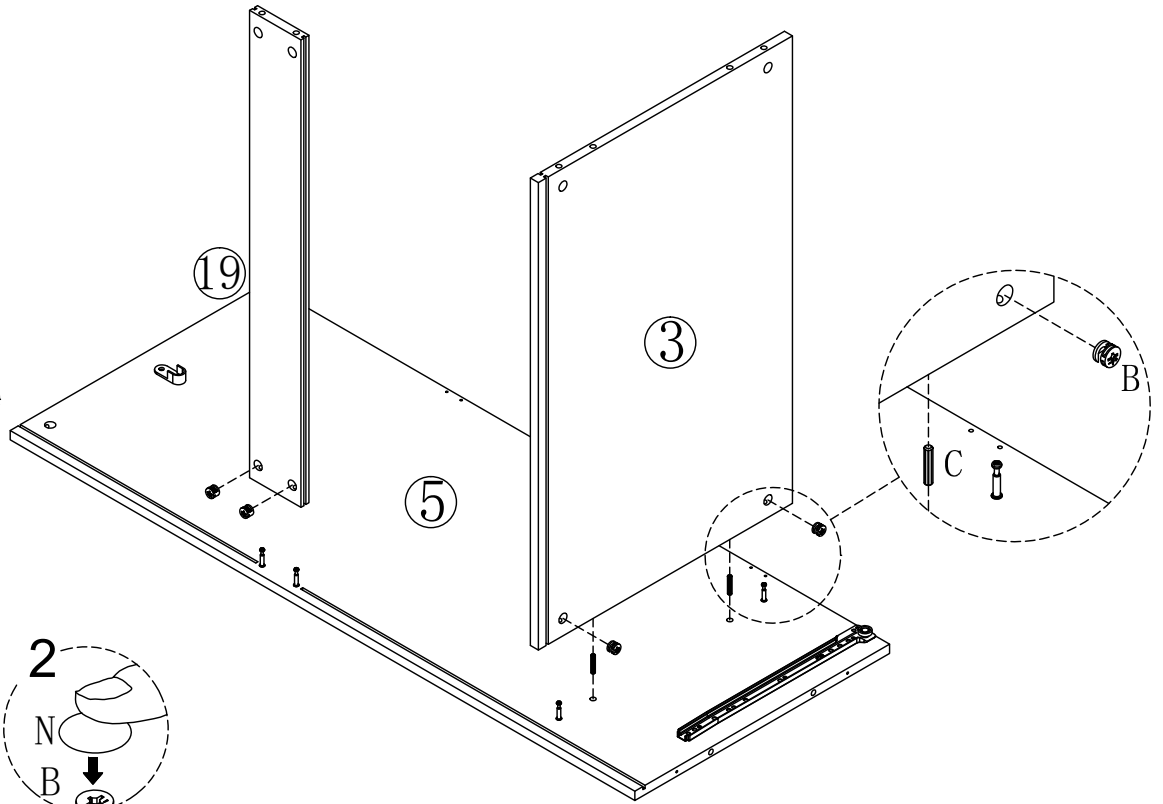
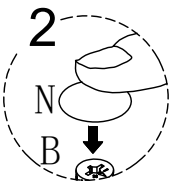
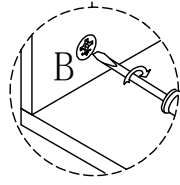
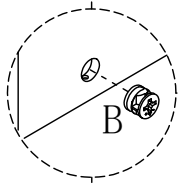
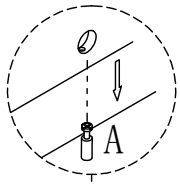

5

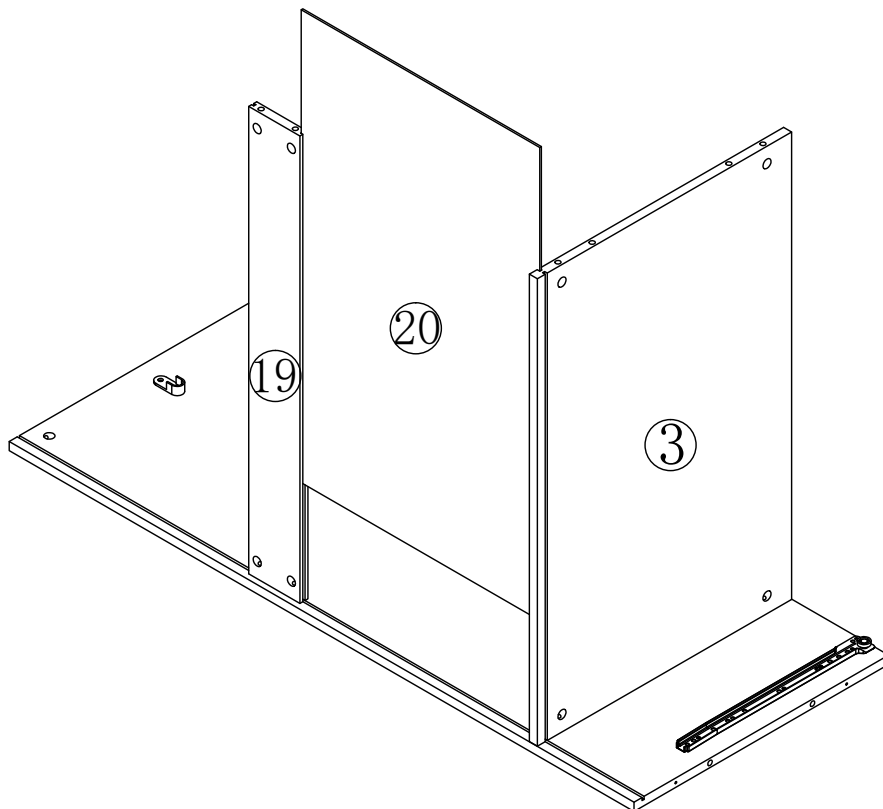

6

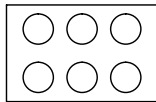

N x4pcs



Ø15x9mm

B x4pcs



Ø8x30mm

C x2pcs

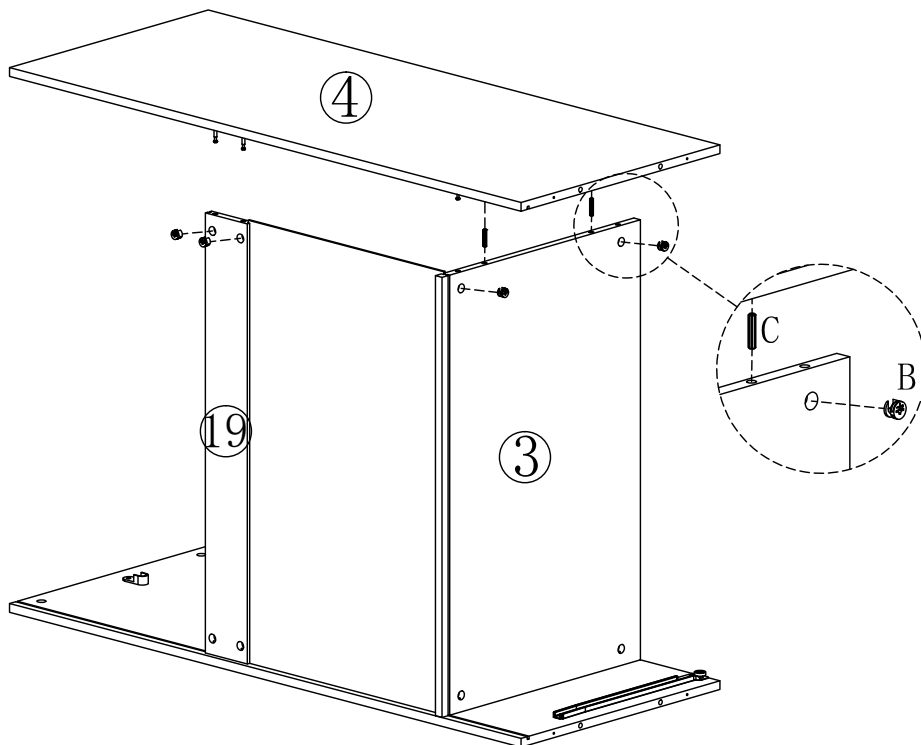
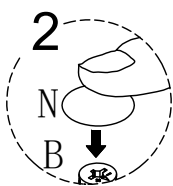
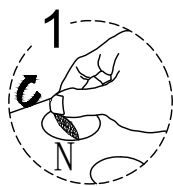
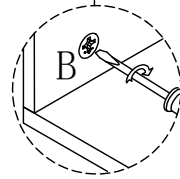
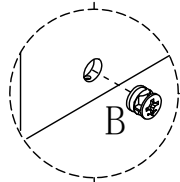
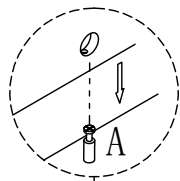

7



Ø8x30mm

C x4pcs

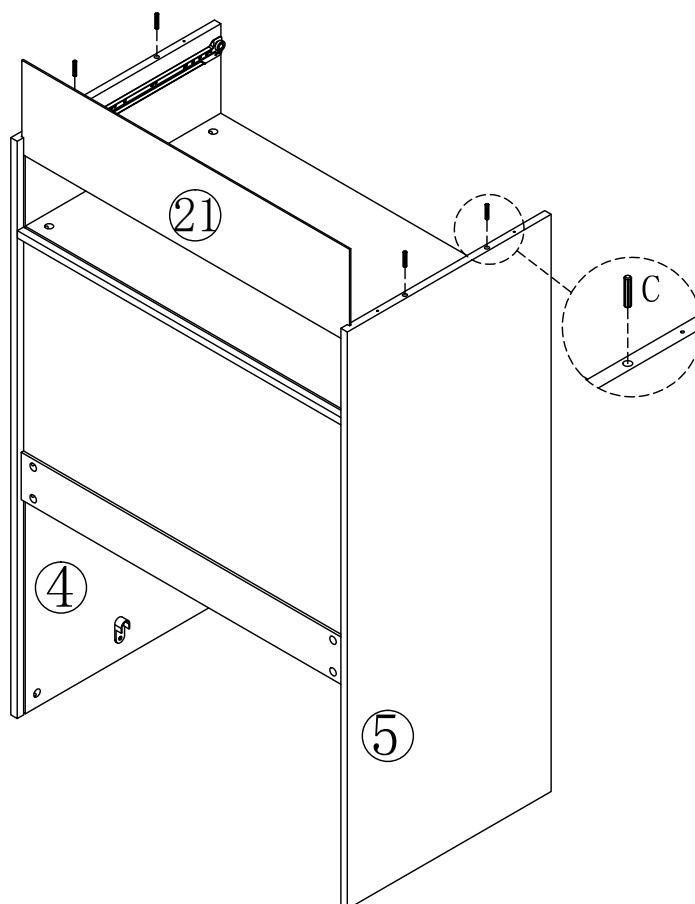

8

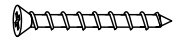
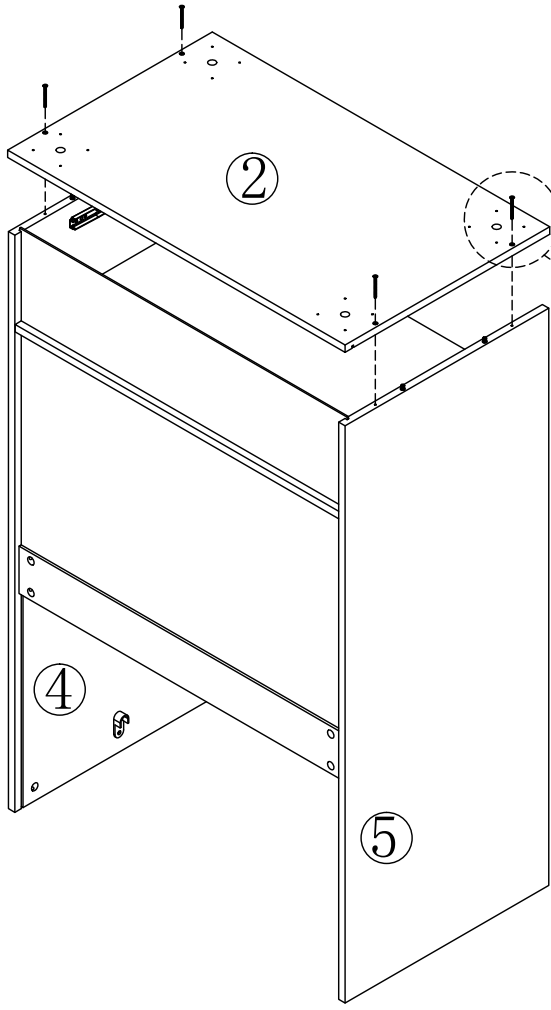

M4x40mm

ⓓx4pcs

9

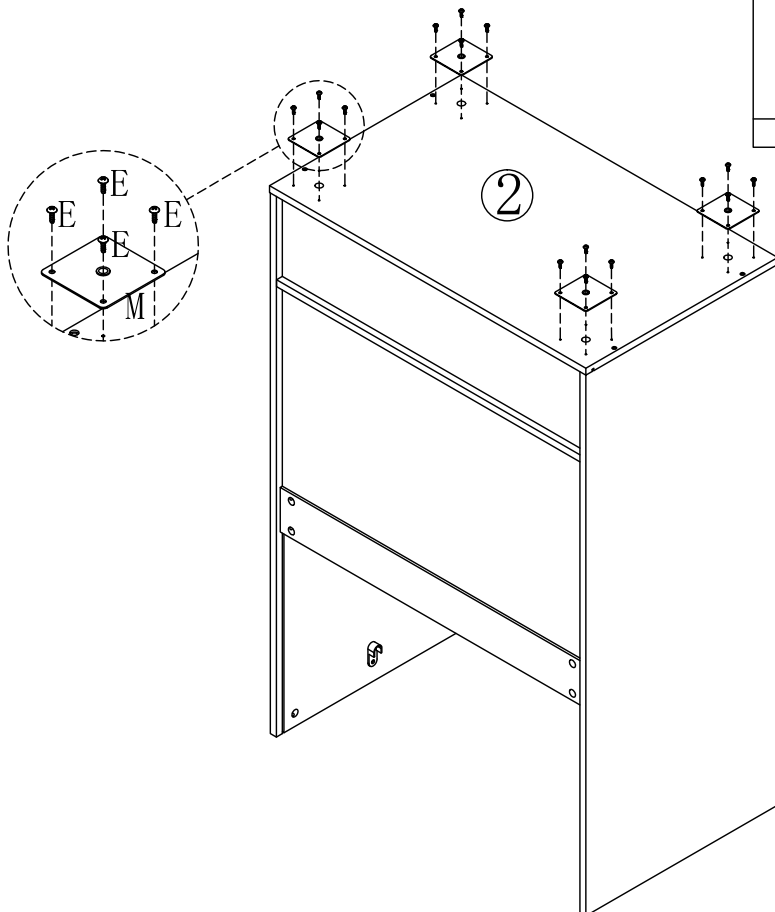

Ⓜx4pcs



M3.5x14mm

ⓔx16pcs

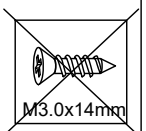

~~M3.0x14mm~~

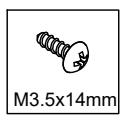

M3.5x14mm

10

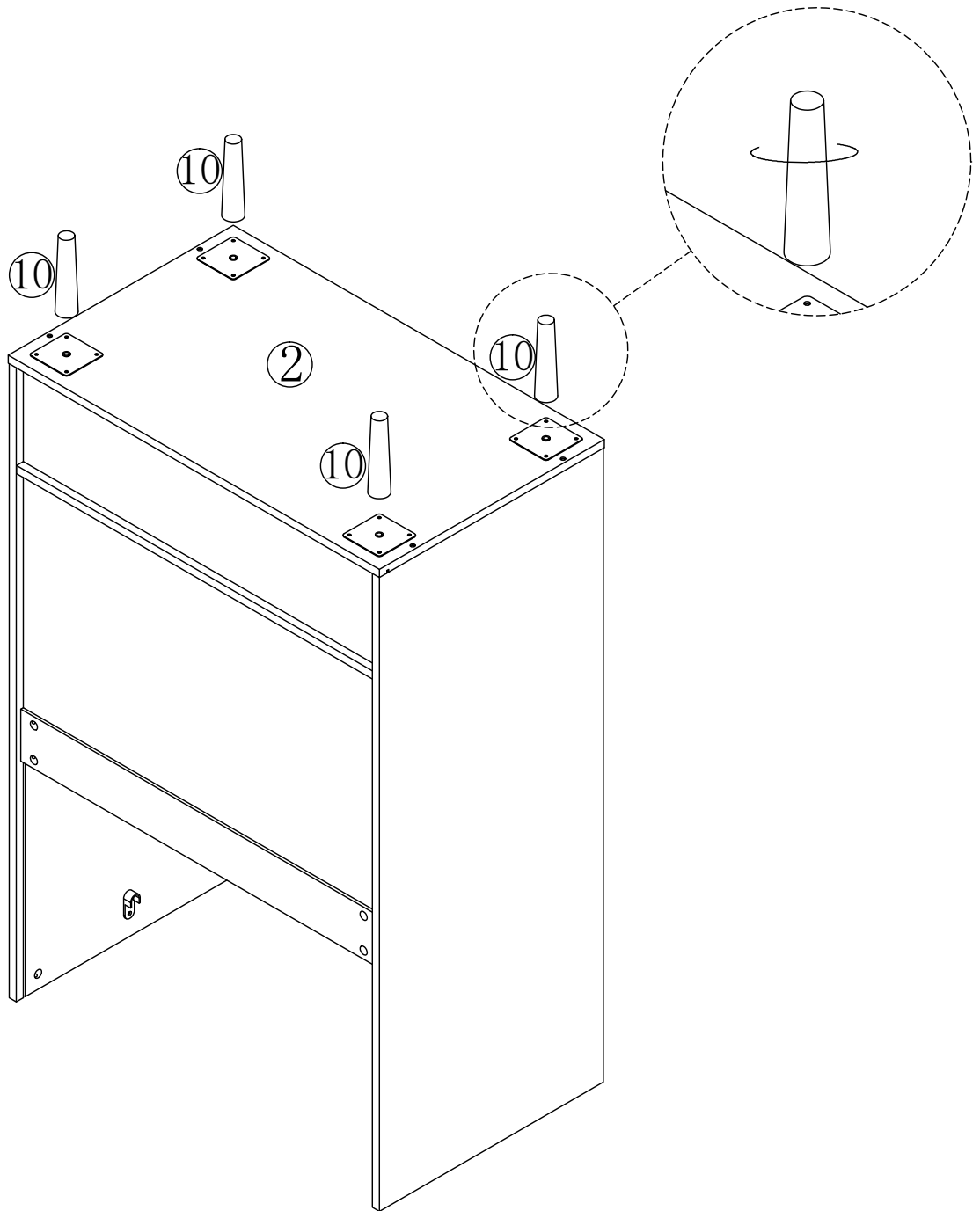

11

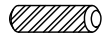

Ø8x30mm

©x4pcs

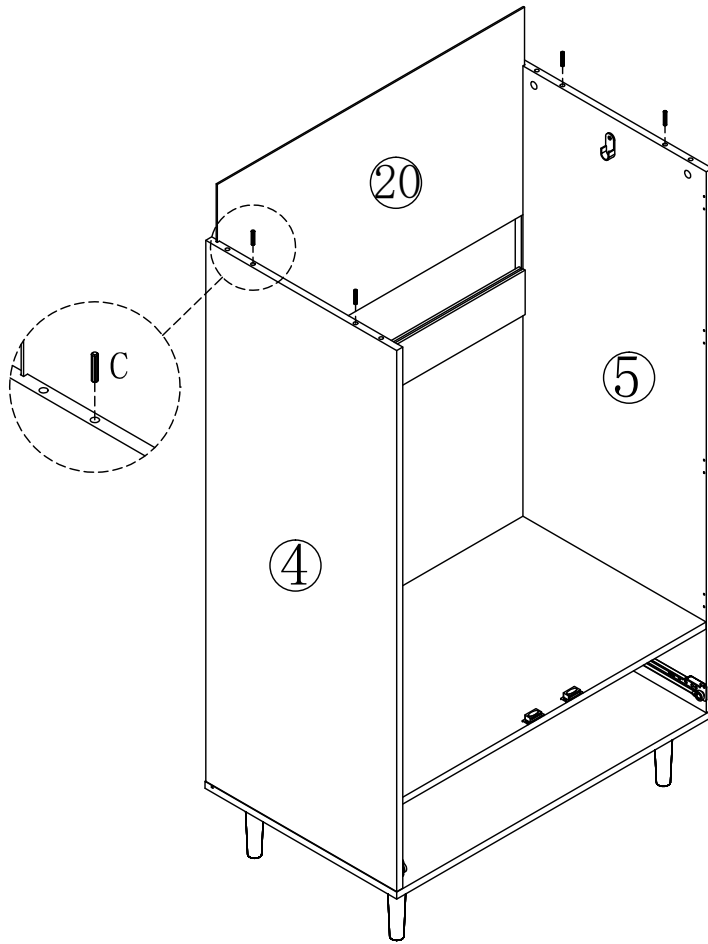

12

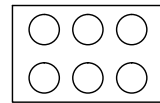

Ⓝx5pcs



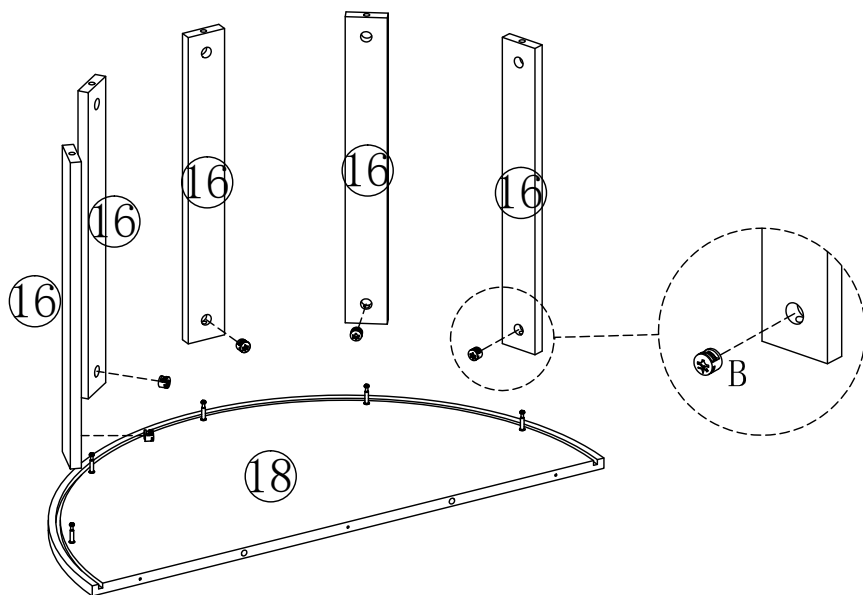
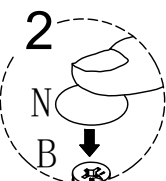
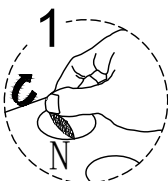
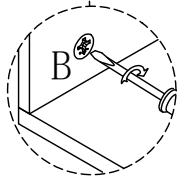
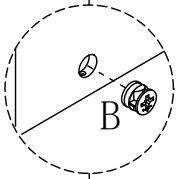
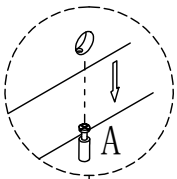

Ø15x9mm

ⓑx5pcs

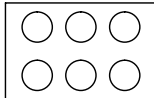

13

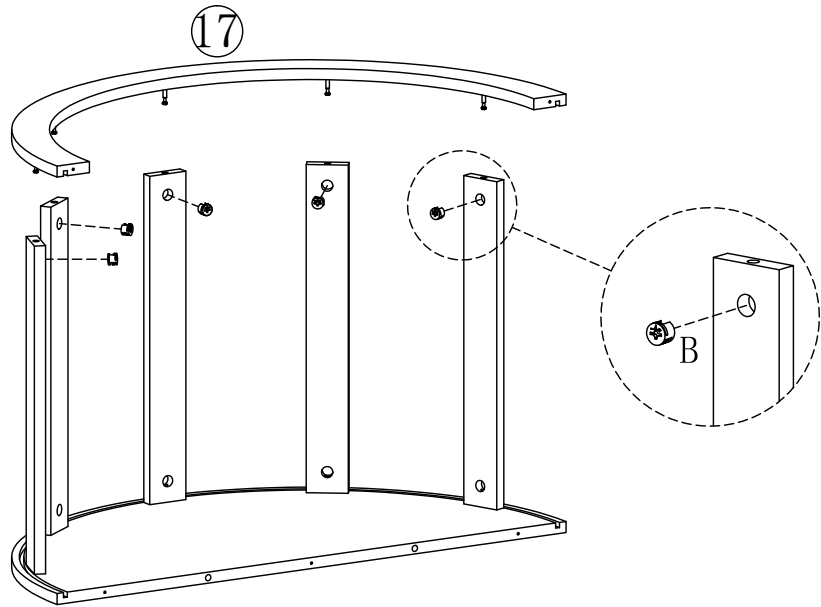
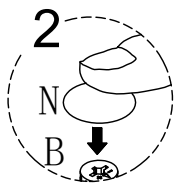
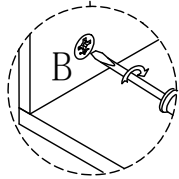
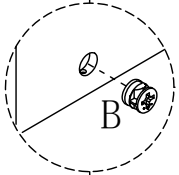
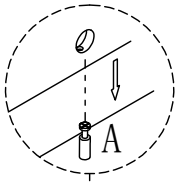

	
Ⓐ x5pcs	Ⓑ x5pcs

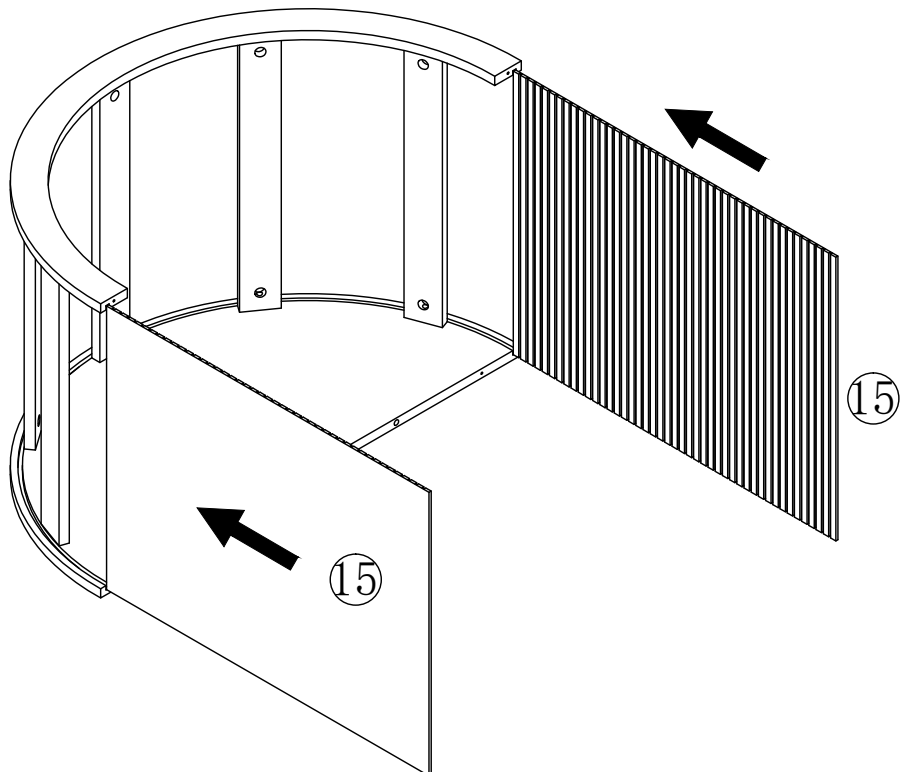

14



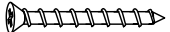

15

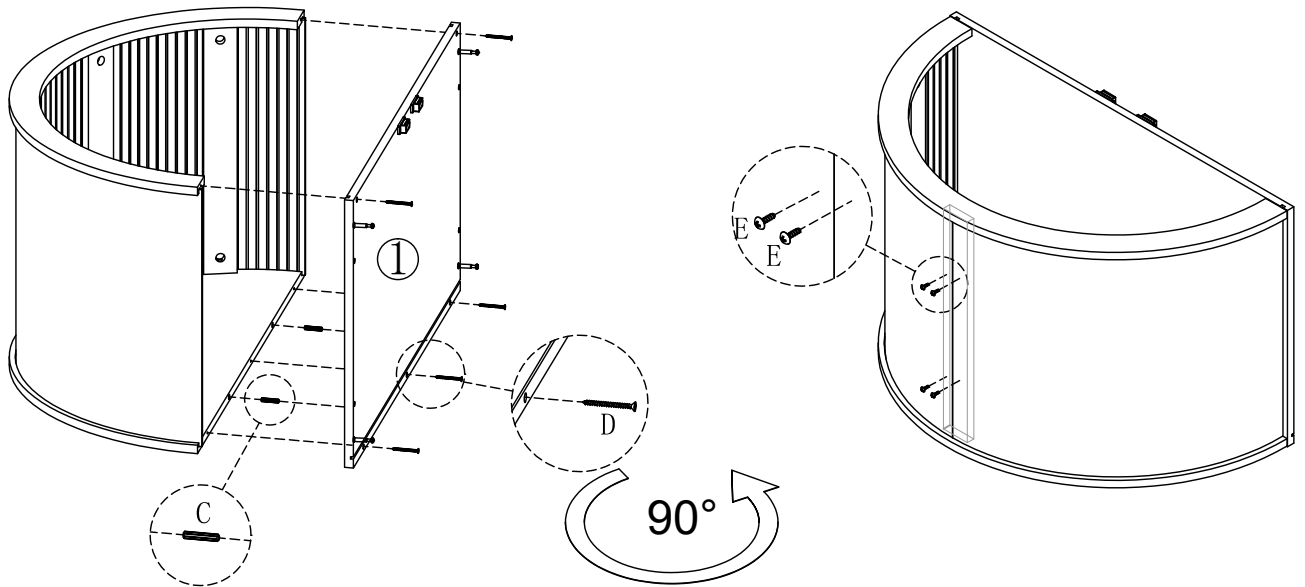
		
M3.5x14mm	Ø8x30mm	M4x40mm
Ⓔx4pcs	Ⓒx2pcs	Ⓓx5pcs

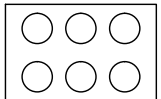

16

	
Ⓝx4pcs	Ø15x9mm
	Ⓑx4pcs

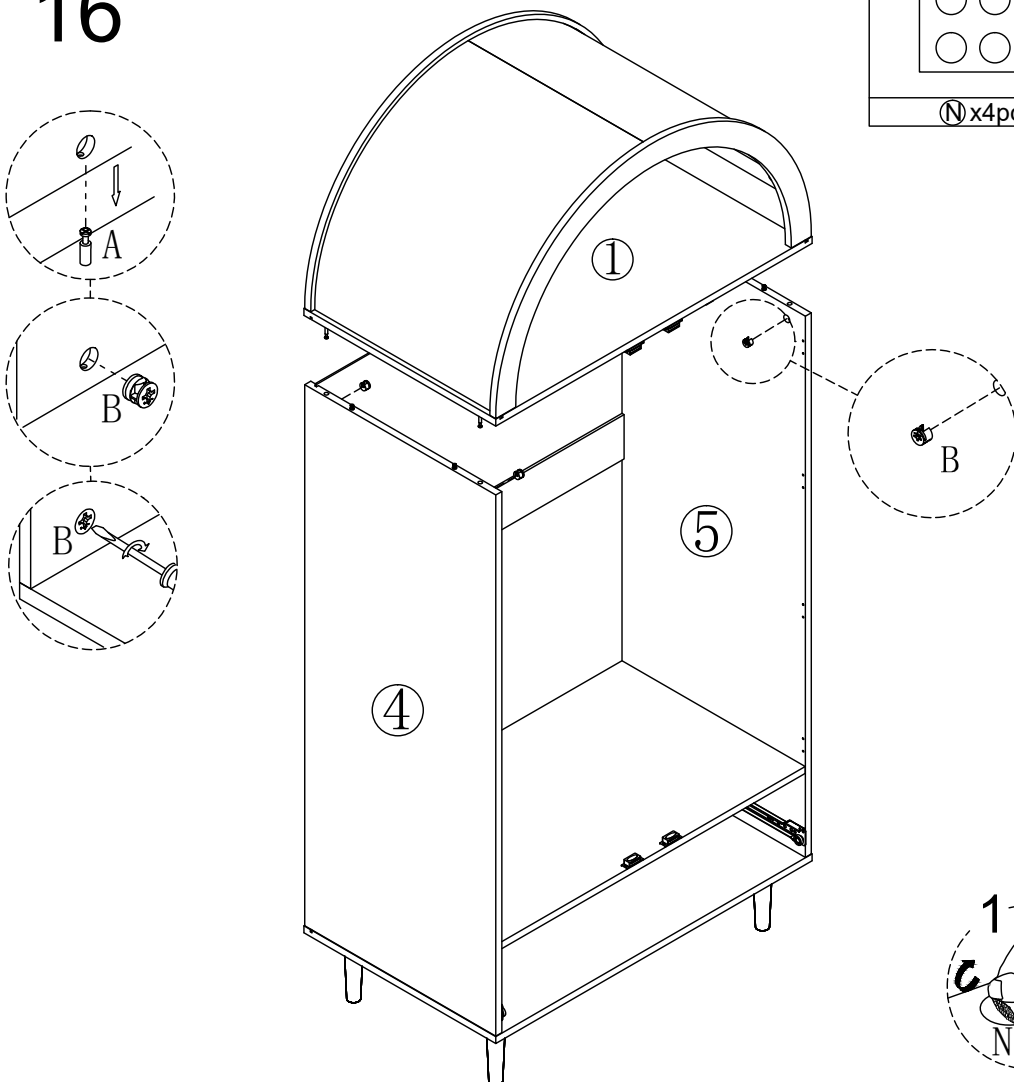

17

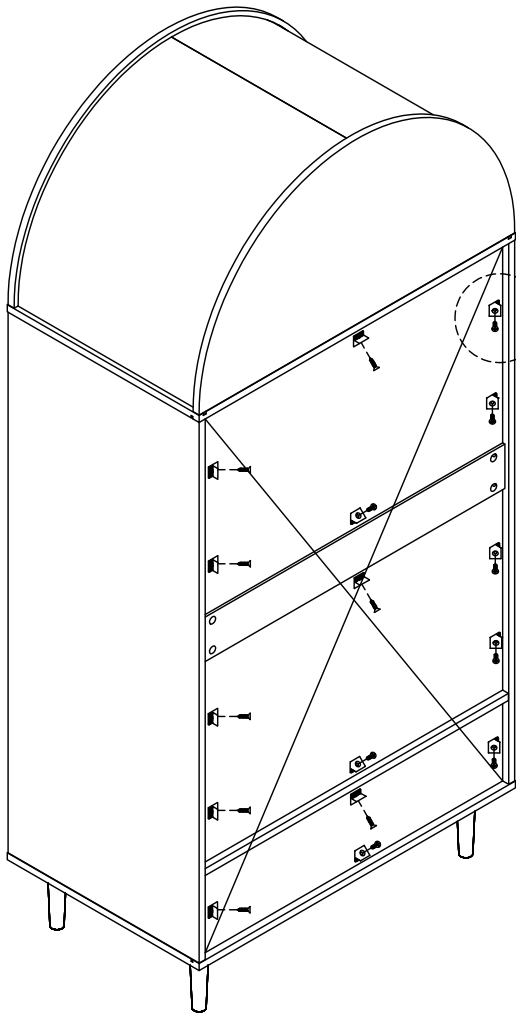

M3.0x14mm

Ⓜx16pcs



Ⓛx16pcs

DE: Bevor Sie I montieren, messen Sie bitte die Diagonalen und stellen Sie sicher, dass sie gleich lang sind, um den Schrank senkrecht auszurichten.

EN: Before installing I, please measure the diagonals to ensure they are equal in length, keeping the cabinet upright.

FR: Avant d'installer I, veuillez mesurer les diagonales et vous assurer qu'elles sont de même longueur afin de maintenir l'armoire droite.

IT: Prima di installare I, misurare le diagonali e assicurarsi che siano della stessa lunghezza per mantenere l'armadio in posizione verticale.

ES: Antes de instalar I, mida las diagonales y asegúrese de que tengan la misma longitud para mantener el armario en posición vertical.

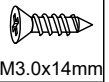

M3.0x14mm

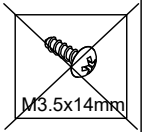

M3.5x14mm

18

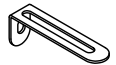
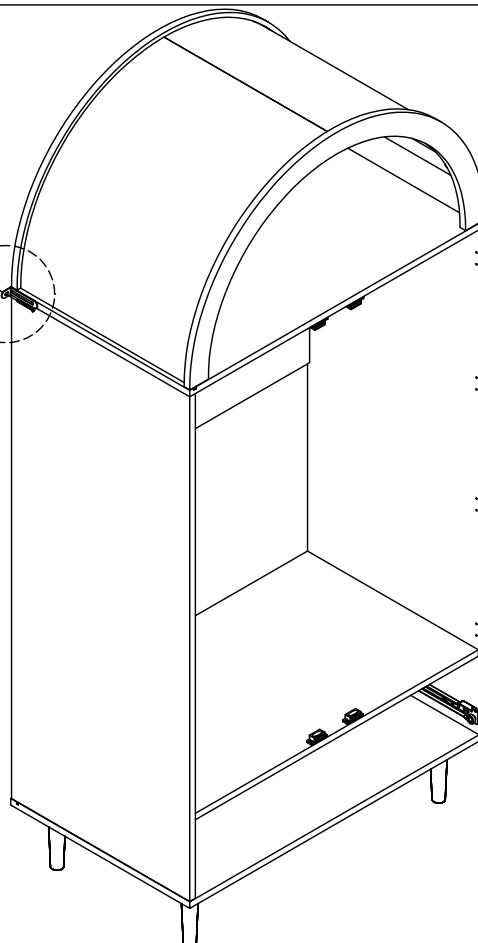

Ⓧx2pcs



Ⓛx2pcs

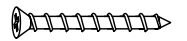

M4x40mm

Ⓧx2pcs

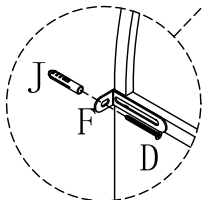
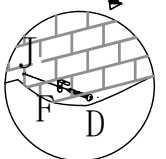
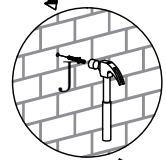

19

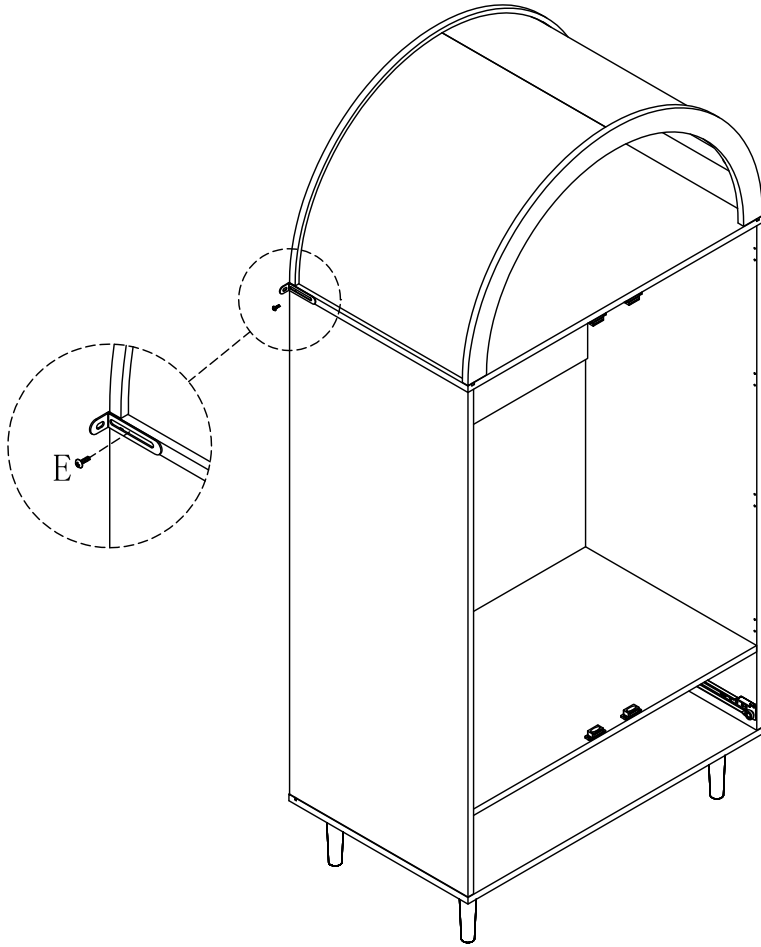

M3.5x14mm

ⓔx2pcs

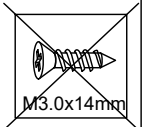

M3.0x14mm



M3.5x14mm

20

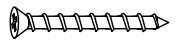
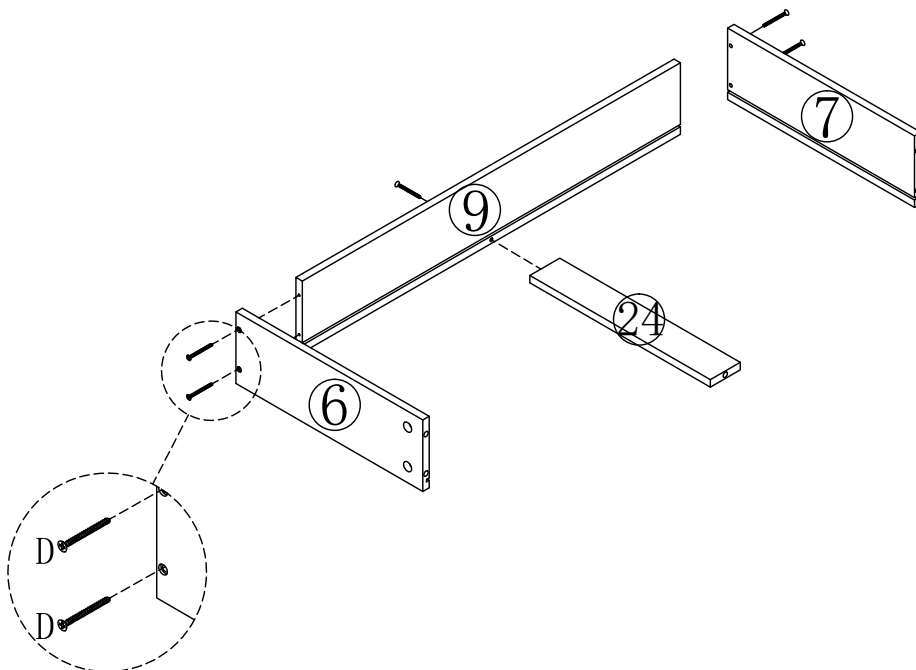



M4x40mm

ⓓx5pcs

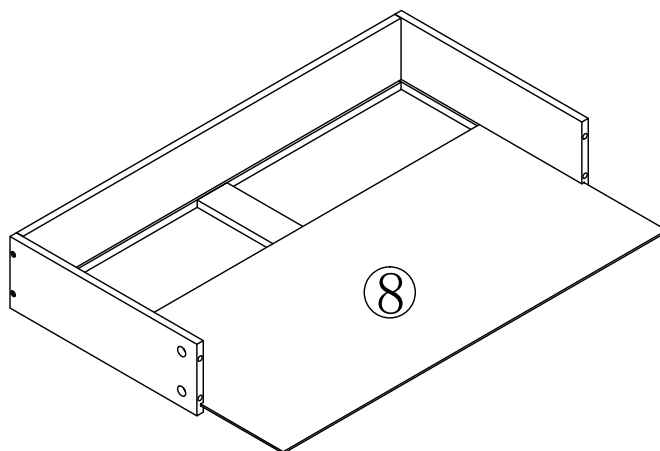
21

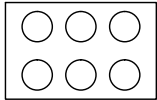

22

	
Ⓝ x5pcs	Ⓟ x5pcs

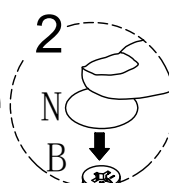
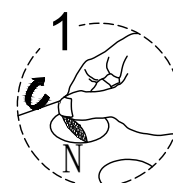
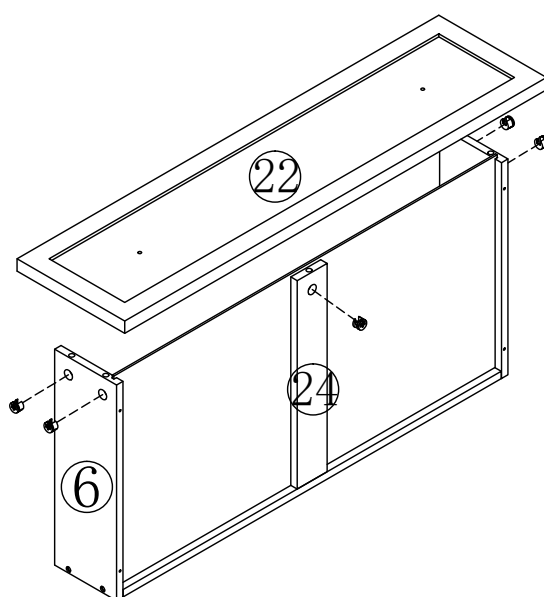
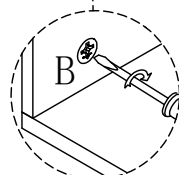
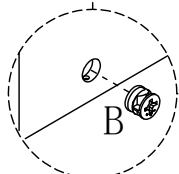
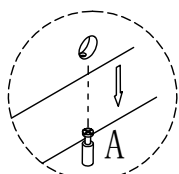

23



DL 350mm

Ⓛx1pc

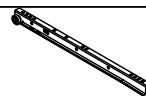

DR 350mm

Ⓛx1pc



M3.0x14mm

Ⓜx4pcs

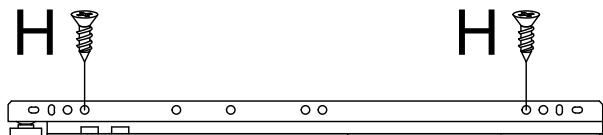

H



H

H

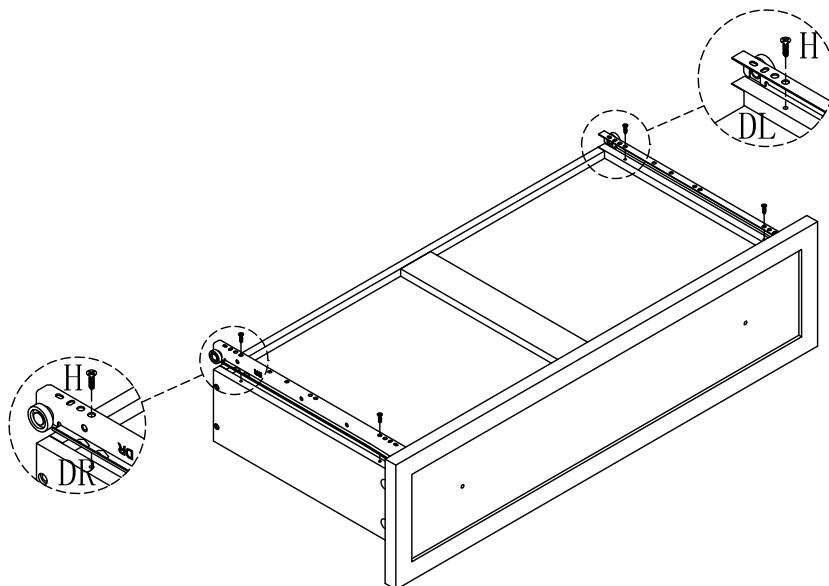

24



M4x20mm

Ⓛx2pcs



Ⓢx2pcs

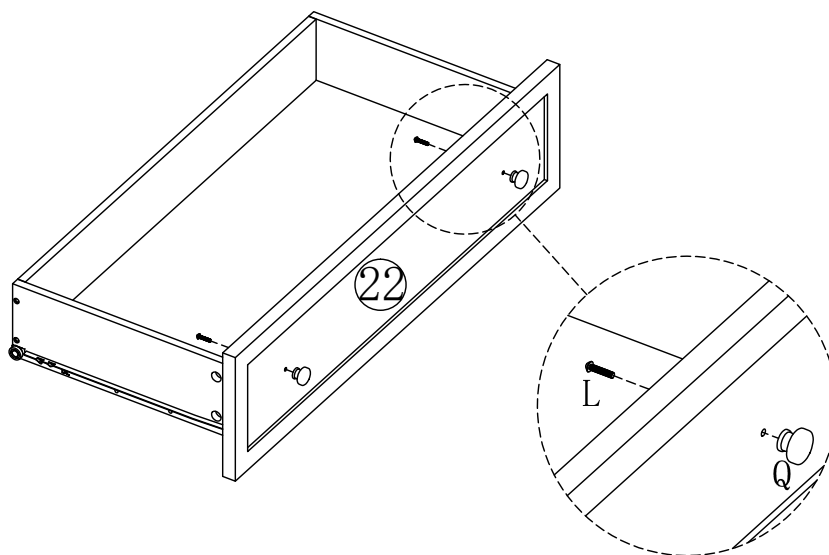

22

L

S

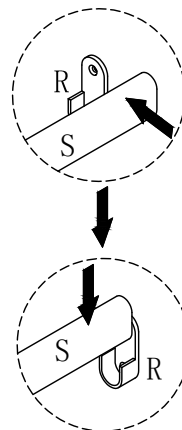
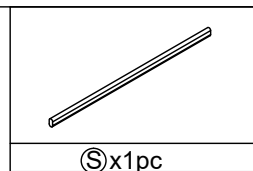
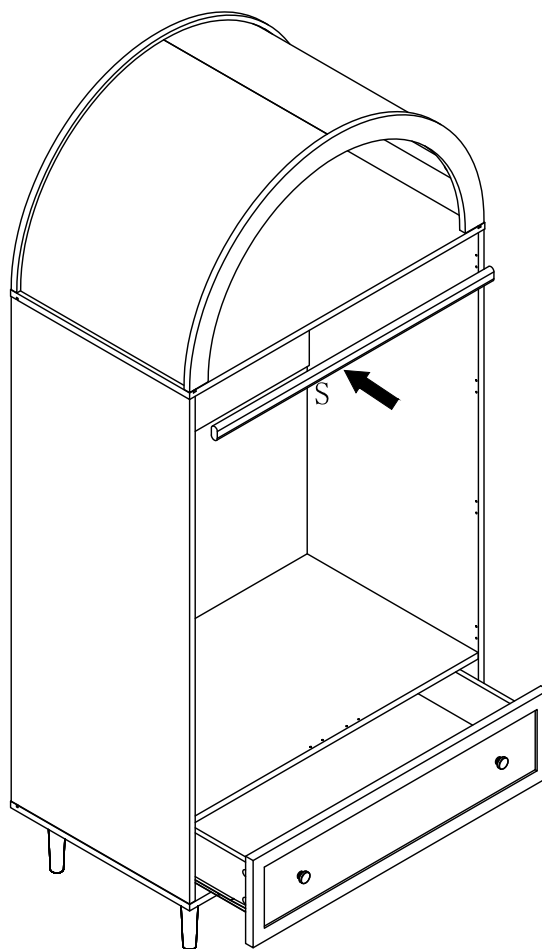

25

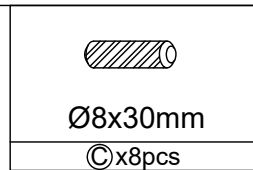
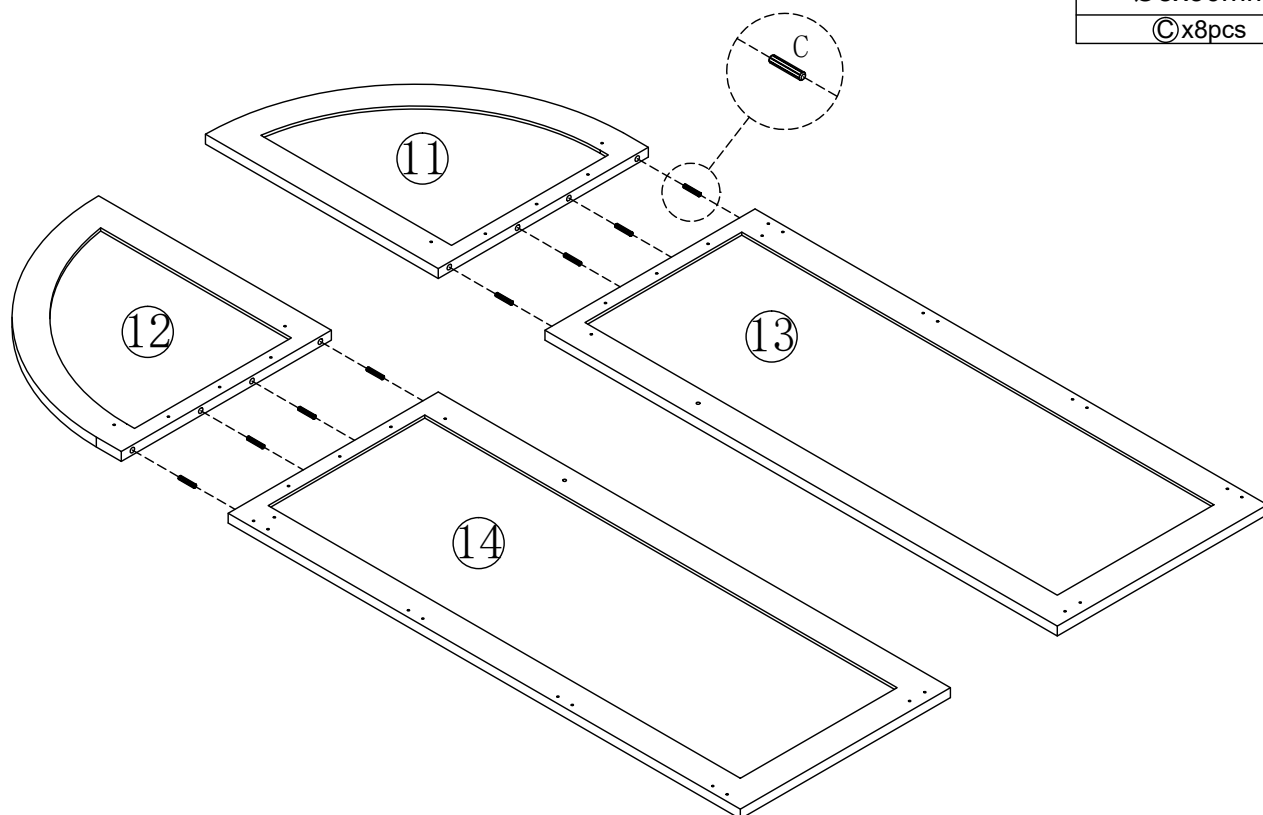

26

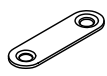

27

		
Ⓟ x2pcs	Ⓞ x8pcs	M3.0x14mm
		Ⓜ x40pcs

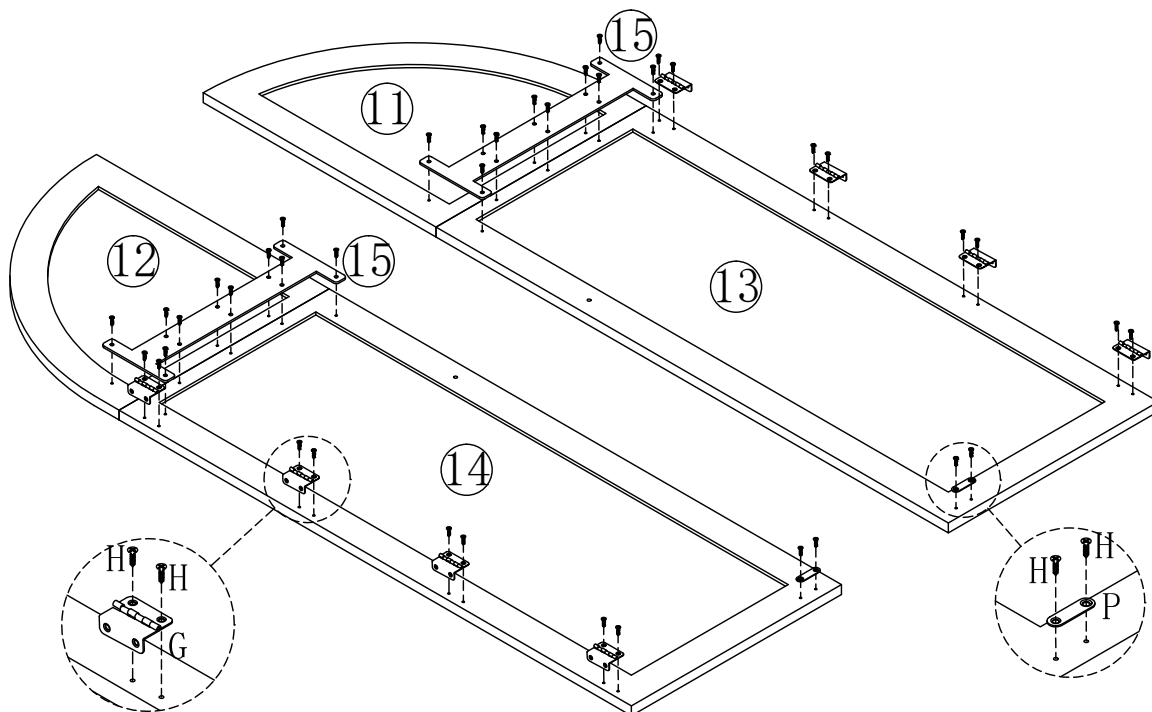

28

M3.0x14mm
Ⓜ x8pcs

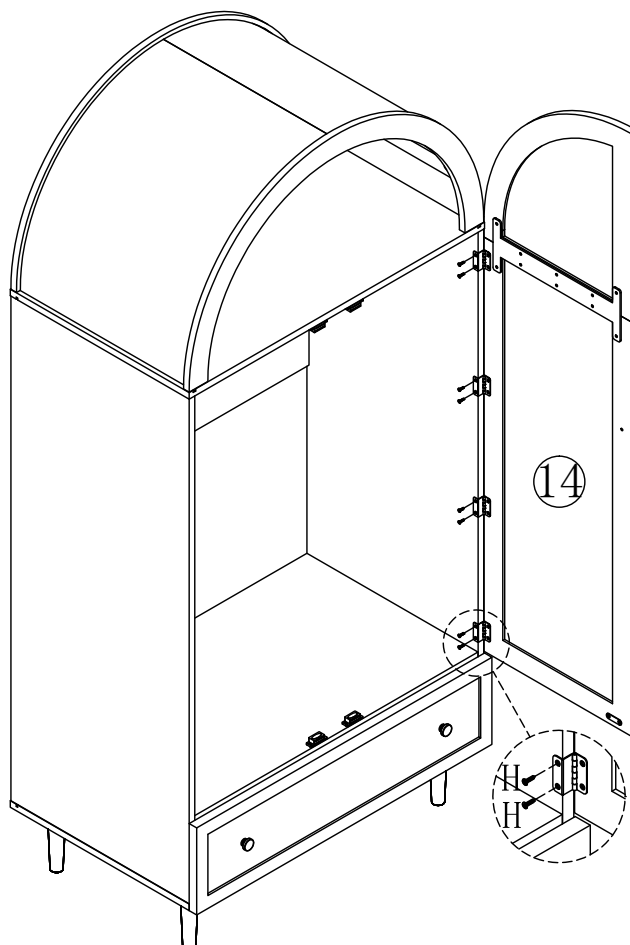

29

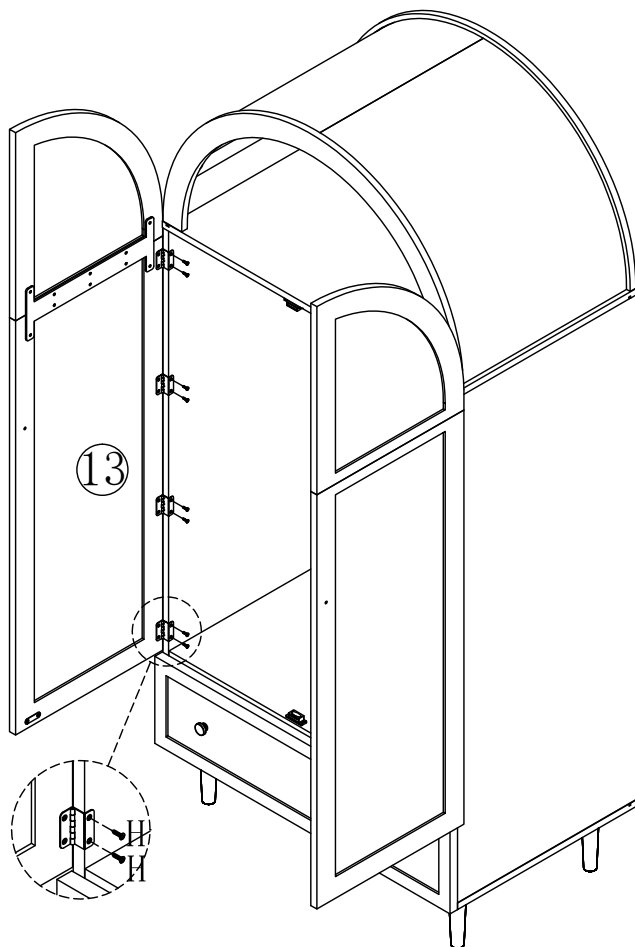

M3.0x14mm

Ⓜ x8pcs

30

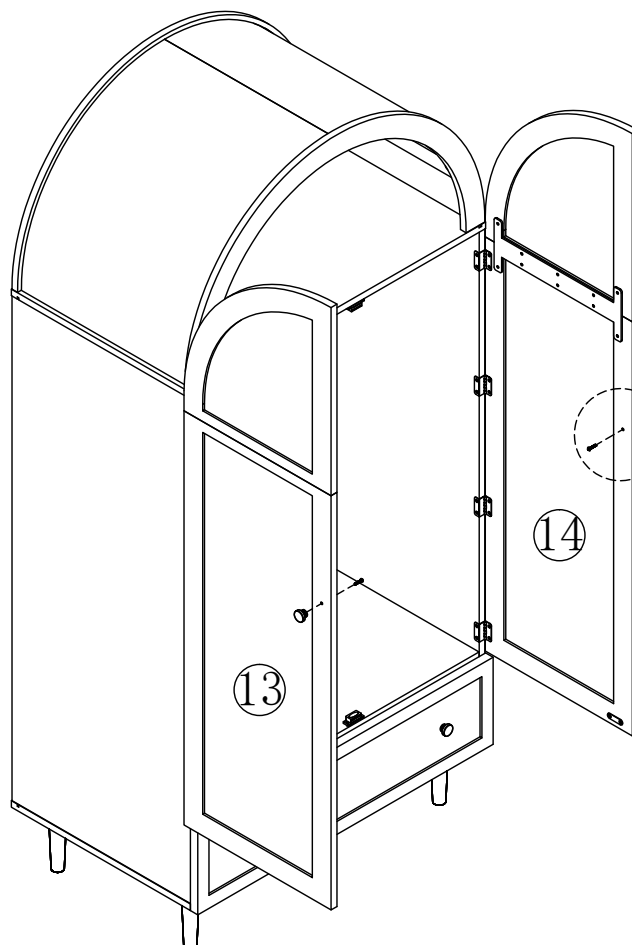

ⓐ x2pcs



M4x20mm

Ⓛ x2pcs

14

13

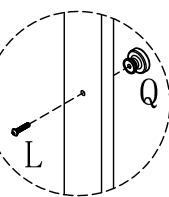

31

