

CARE AND MAINTENANCE

Spot clean using a mild water-free solvent. Only a professional cleaner should undertake a complete overall cleaning.

The use of steam or water-based cleaners may cause excessive shrinking or









NOTICE

* Please make sure that you have all parts indicated before you begin assembly of this item

* This item should be assembled on a soft surface to prevent scratching the finish during assembly

* This item may require periodic tightening

Part List and Hardware List

PIECE	DESCRIPTION	PICTURE	QUANTITY
A	SEAT		1X
B	CHASSIS		1X
C	PEDAL		1X
D	AIR BOLT POLE		1X
E	Spring washer(M8)		4X
F	Metal Gasket(M8)		4X
G	Bolt(M8*30mm)		4X
H	Allen key		1X

Dimensions:21.26"WX22.05"D \times 34.25"H~44.1"H

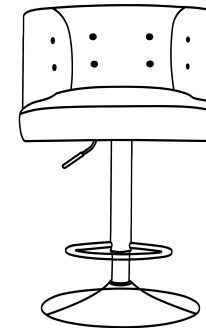

Weight Capacity: 275 lbs

WARNING: DO NOT STAND ON CHAIR

WARNING: DO NOT OVER TORQUE BOLTS/SCREWS

The base and hardware are located around the chair

PREPARATION

Before beginning assembly of product, make sure all parts are present. Compare parts with package contents list and hardware contents list.

If any part is missing or damaged, do not attempt to assemble the product.

Estimated Assembly Time: 10 minutes.

Tools Required for Assembly (included): Allen key

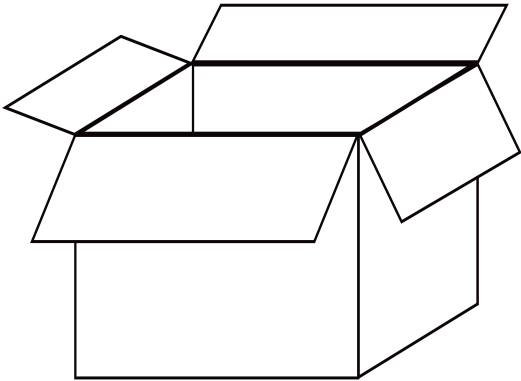
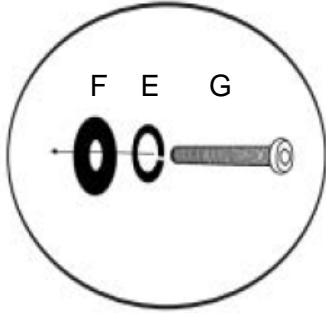
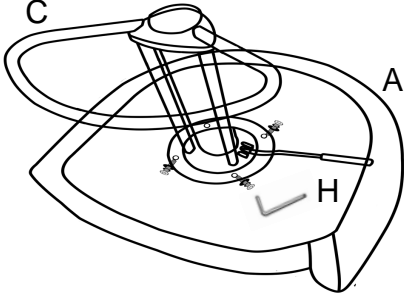
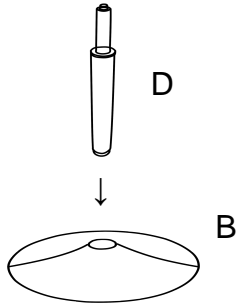
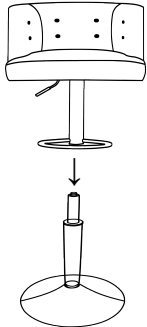
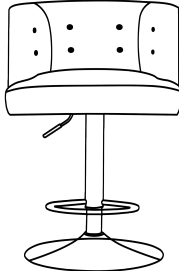
	
<p>STEP1 OPEN THE CARTON BOX AND TAKE OUT BASE AND HARDWARE</p>	<p>STEP2 PUT THE WASHERS ON THE BOLT IN THE ORDER SHOWN IN THE PICTURE</p>
	
<p>STEP3 INSERT THE PEDAL AND SCREW IN THE BOLTS. REPEAT THE SAME STEPS FOR THE OTHER THREE.</p>	<p>STEP4 PUT THE AIR BOLT POLE INTO THE CHASSIS WOLE, IT WILL CONNECT FIRMLY ONCE SOMEONE SITS AFTER FINISHED</p>
	
<p>STEP5 PUT THE FINISHED PERT OF STEP3 AND STEP4 TOGETHER, IT WILL CONNECT FIRMLY ONCE SOMEONE SITS AFTER FINISHED</p>	<p>STEP6 FINISHED.</p>
<p>The base and hardware are located around the chair</p>	