

ASSEMBLY INSTRUCTIONS



Fine Furniture for every stage of life

Twin Bed

ASSEMBLY INSTRUCTIONS

ASSEMBLY TIPS:

1. Remove hardware from box and sort by size.
2. Please check to see that all hardware and parts are present prior to start of assembly.
3. Please follow attached instructions in the same sequence as numbered to assure fast & easy assembly.



WARNING!

1. Don't attempt to repair or modify parts that are broken or defective. Please contact the store immediately.
2. This product is for home use only and not intended for commercial establishments.









ASSEMBLY TIME





20 MINUTES

PARTS IDENTIFICATION

B1 (BOX 1)

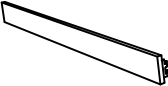
| | | | | | | | | |
|---|-----------------------|---|-----|--|---|--------------------------|---|------|
| A | HEADBOARD PANEL |  | 1PC | | D | RIGHT HEADBOARD LEG |  | 1PC |
| B | FOOTBOARD PANEL |  | 1PC | | E | FOOTBOARD SUPPORT BAR |  | 1PC |
| C | LEFT HEADBOARD LEG |  | 1PC | | F | BED SLAT |  | 4PCS |

B2 (BOX 2)

| | | | | | | | | |
|----|----------------------------------|---|-----|--|----|-------------------------------------|---|------|
| G | LEFT BED RAIL |  | 1PC | | I | FOOTBOARD LEG |  | 2PCS |
| H | RIGHT BED RAIL |  | 1PC | | HB | FROM BOX 1 HEADBOARD COMPLETE |  | 1PC |
| FB | FROM BOX 1 FOOTBOARD PANEL |  | 1PC | | | | | |

NOTE:

Phillips head screw driver is required in the assembly process; however, manufacturer does not provide this item.

ASSEMBLY INSTRUCTIONS

ASSEMBLY TIPS:

1. Remove hardware from box and sort by size.
2. Please check to see that all hardware and parts are present prior to start of assembly.
3. Please follow attached instructions in the same sequence as numbered to assure fast & easy assembly.







WARNING!



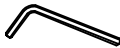

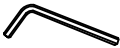

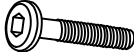
1. Don't attempt to repair or modify parts that are broken or defective. Please contact the store immediately.
2. This product is for home use only and not intended for commercial establishments.

HARDWARE IDENTIFICATION

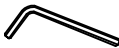
BOX 1 - HARDWARE PACK

| | | | | | | | |
|---|--|---|------|---|--|---|------|
| 1 | SMALL ALLEN WRENCH (M4 x 65mm - BLK) |  | 1PC | 4 | LOCK WASHER (1/4" - BLK) |  | 6PCS |
| 2 | BIG ALLEN WRENCH (M5 x 65mm - BLK) |  | 1PC | 5 | FLAT WASHER (1/4" ID x 13mm - BLK) |  | 6PCS |
| 3 | SHORT BOLT (M6 x 35mm - BLK) |  | 6PCS | | | | |

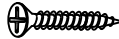
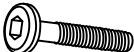
BOX 2 - HARDWARE PACK

| | | | | | | | |
|---|--|---|------|----|---|---|------|
| 6 | SMALL ALLEN WRENCH (M4 x 65mm - BLK) |  | 1PC | 10 | LOCK WASHER (1/4" - BLK) |  | 6PCS |
| 7 | BIG ALLEN WRENCH (M5 x 65mm - BLK) |  | 1PC | 11 | FLAT WASHER (1/4" ID x 13mm - BLK) |  | 6PCS |
| 8 | LONG BOLT (M6 x 80mm - BLK) |  | 2PCS | 12 | SHORT FLAT HEAD SCREW (M4 x 32mm - RBW) |  | 8PCS |
| 9 | MEDIUM BOLT (M6 x 50mm - BLK) |  | 4PCS | 13 | LONG FLAT HEAD SCREW (M4 x 50mm - RBW) |  | 4PCS |

NOTE:

Phillips head screw driver is required in the assembly process; however, manufacturer does not provide this item.

ASSEMBLY INSTRUCTIONS

STEP 1

Note : Please take note of the marking sticker (L&R) on the headboard legs.

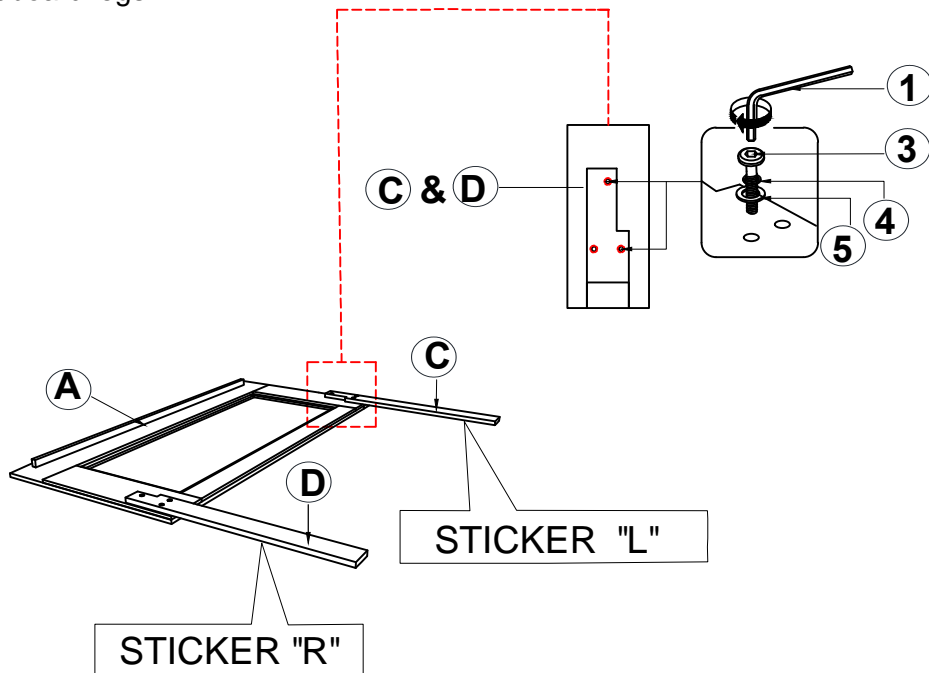

****BACK VIEW****

STEP 2

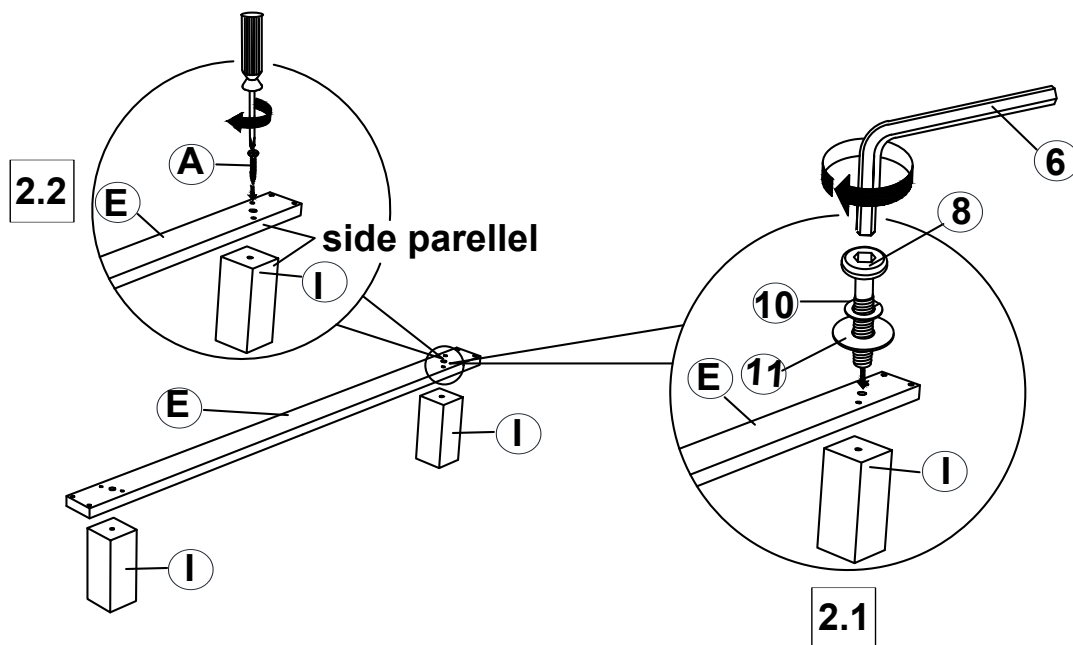

ASSEMBLY INSTRUCTIONS

STEP 3

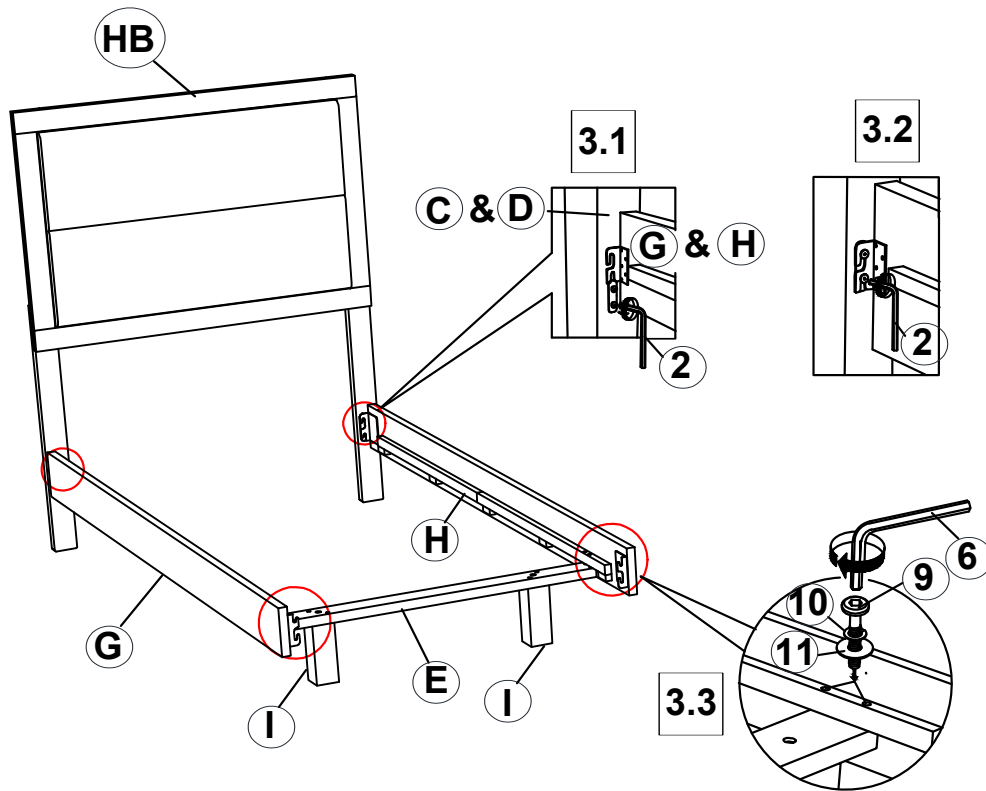

STEP 4

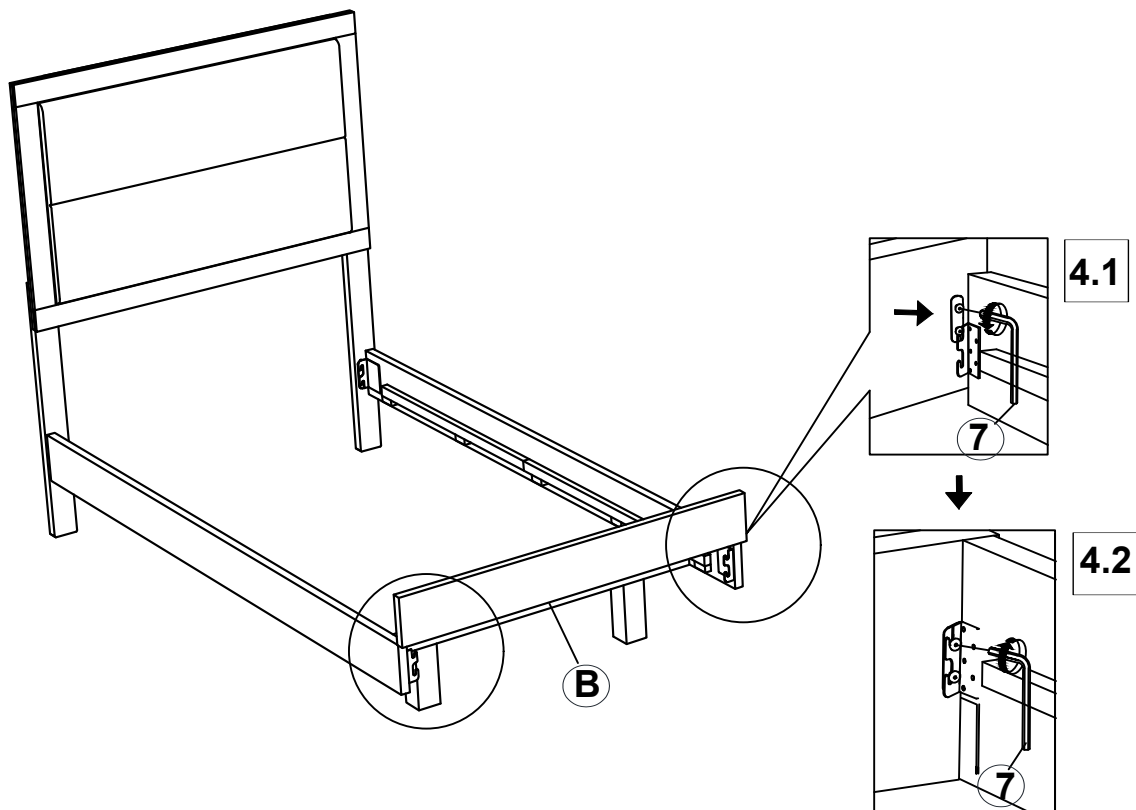

ASSEMBLY INSTRUCTIONS

STEP 5

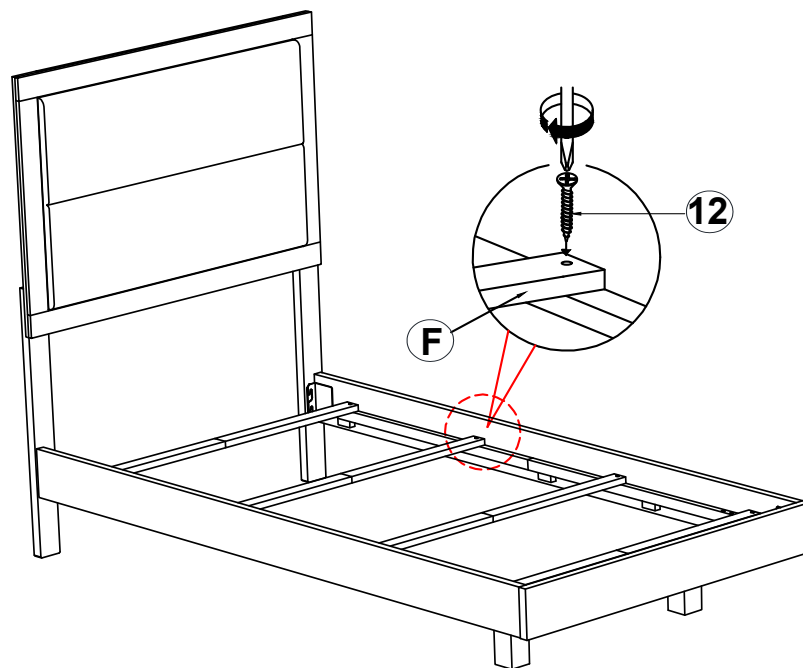

STEP 6

COMPLETE

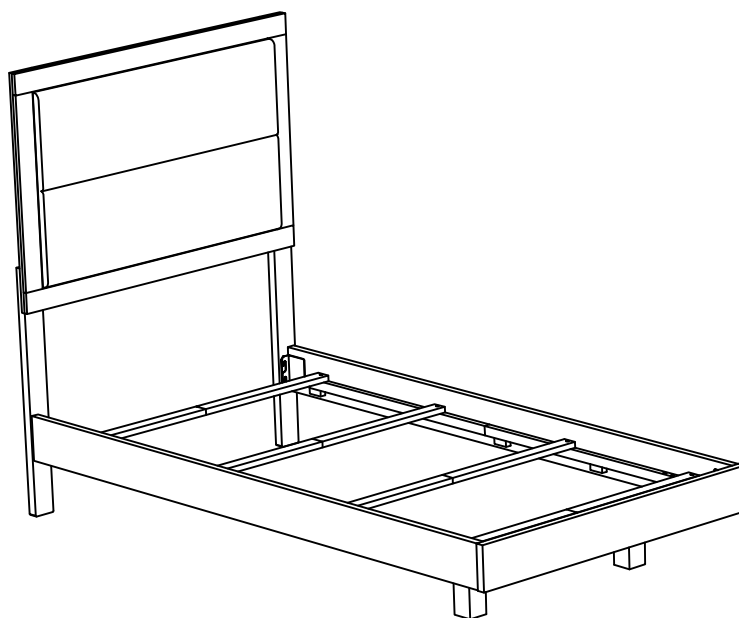

Inner Size : 39.75"W X 76.00"D

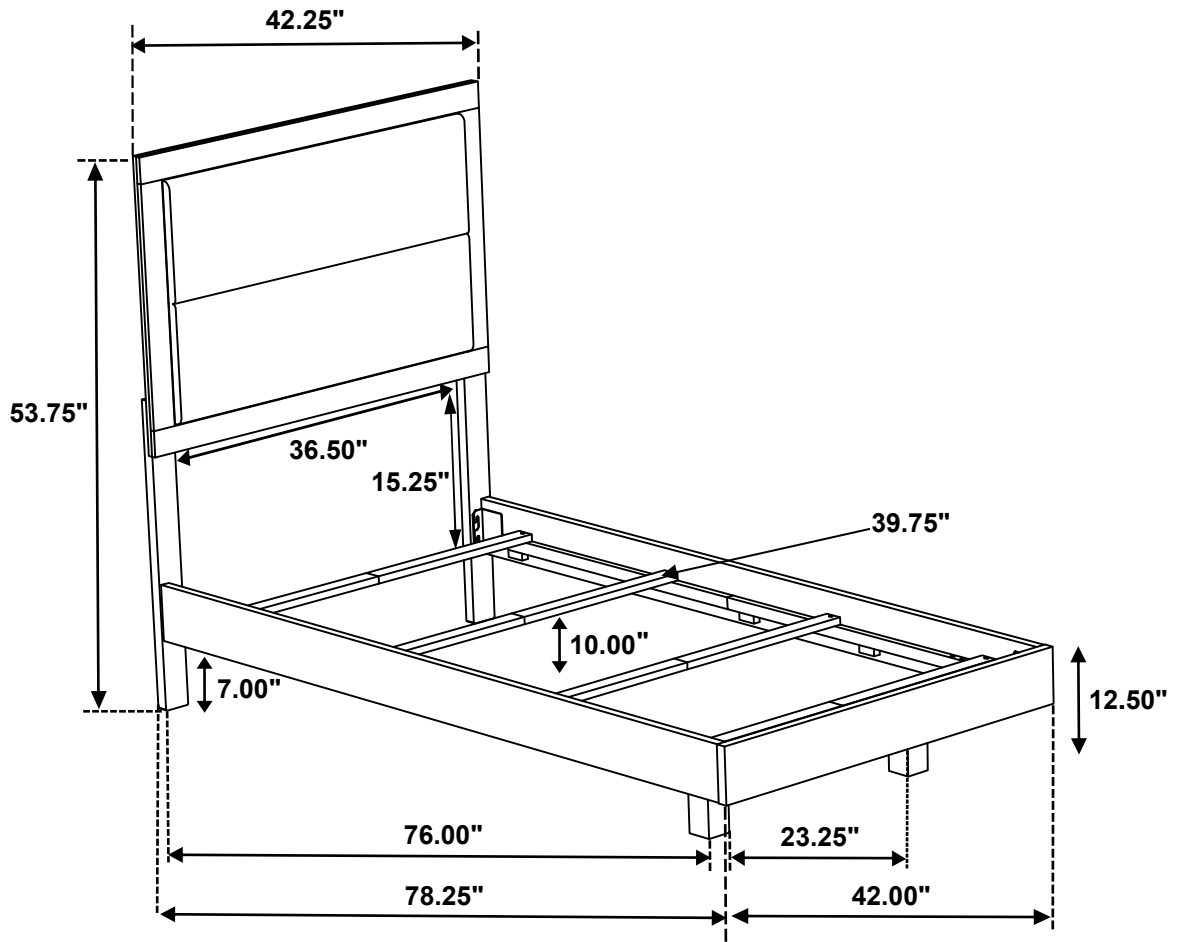

Note : Dimension tolerance $\pm 5\%$

ASSEMBLY INSTRUCTIONS

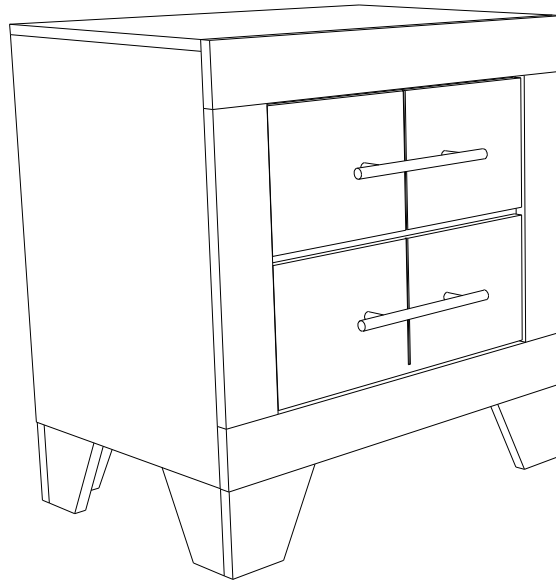

Fine Furniture for every stage of life

Nightstand

ASSEMBLY INSTRUCTIONS

ASSEMBLY TIPS:

1. Remove hardware from box and sort by size.
2. Please check to see that all hardware and parts are present prior to start of assembly.
3. Please follow attached instructions in the same sequence as numbered to assure fast & easy assembly.



WARNING!

1. Don't attempt to repair or modify parts that are broken or defective. Please contact the store immediately.
2. This product is for home use only and not intended for commercial establishments.



ASSEMBLY TIME

5 MINUTES

PARTS IDENTIFICATION

A NIGHTSTAND

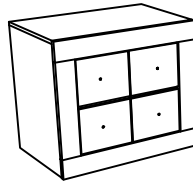

1PC

B LEG WITH LABEL "R"



2PCS

C LEG WITH LABEL "L"



2PCS

HARDWARE IDENTIFICATION

1

BOLT
(M6 x 35mm - BLK)



4PCS

2

LOCK WASHER
(1/4" - BLK)



4PCS

3

FLAT WASHER
(1/4" ID x 19mm - BLK)



4PCS

4

WOOD DOWEL
(8 x 20mm)



4PCS

5

ALLEN WRENCH
(M4 x 60mm - BLK)



1PC

NOTE:

Phillips head screw driver is required in the assembly process; however, manufacturer does not provide this item.

ASSEMBLY INSTRUCTIONS

STEP 1

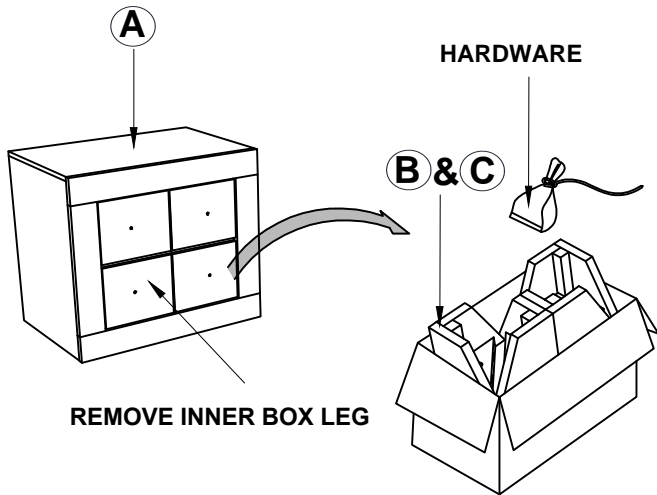

STEP 2

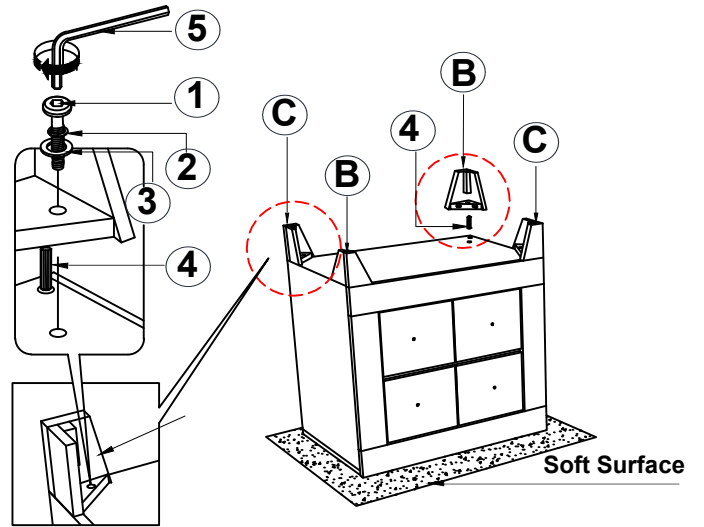

Bottom View

STEP 3

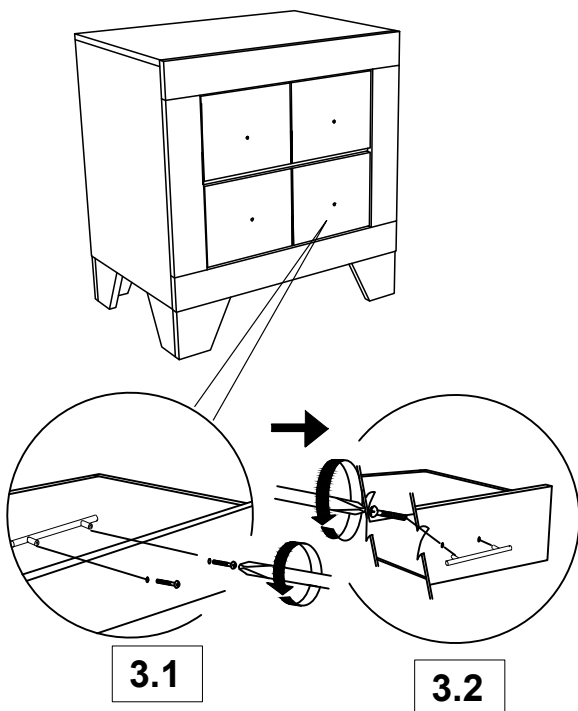

STEP 4 COMPLETE

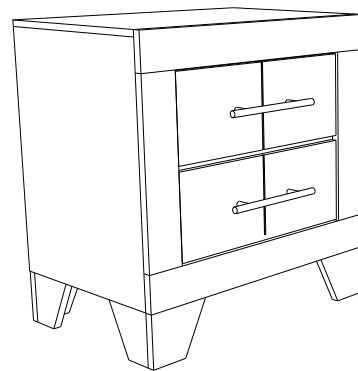

Inner Size of Drawer : 12.75"W x 11.25"D x 4.25"H x 0.25"T

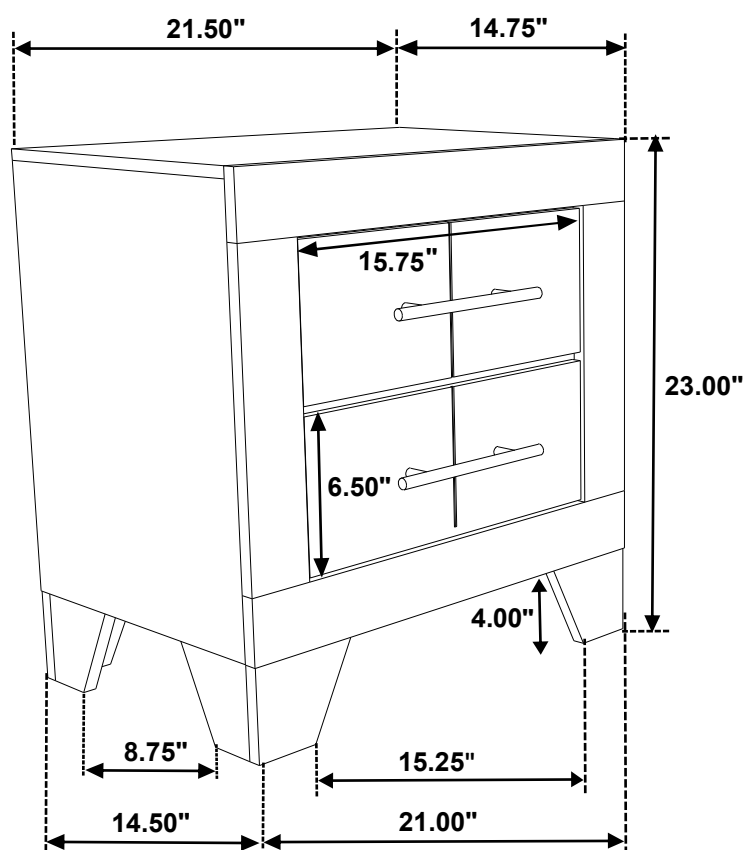

Note : Dimension tolerance $\pm 5\%$

ASSEMBLY INSTRUCTIONS

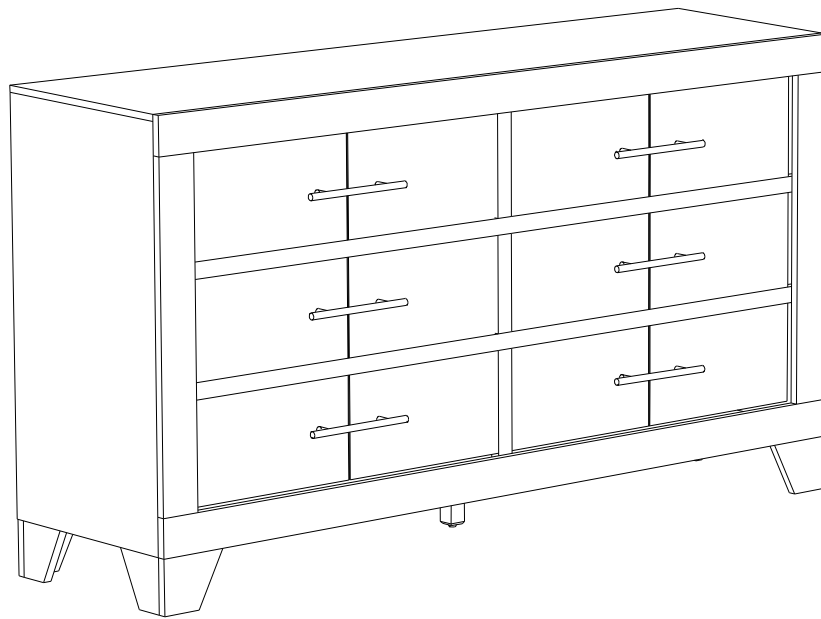

Fine Furniture for every stage of life

Dresser

ASSEMBLY INSTRUCTIONS

ASSEMBLY TIPS:

1. Remove hardware from box and sort by size.
2. Please check to see that all hardware and parts are present prior to start of assembly.
3. Please follow attached instructions in the same sequence as numbered to assure fast & easy assembly.



WARNING!





1. Don't attempt to repair or modify parts that are broken or defective. Please contact the store immediately.
2. This product is for home use only and not intended for commercial establishments.





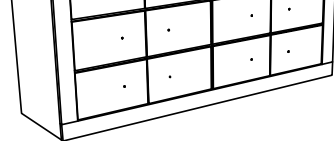

ASSEMBLY TIME

5 MINUTES

PARTS IDENTIFICATION

| | | | |
|---|---------------------------------|---|------|
| A | DRESSER |  | 1PC |
| B | LEG WITH LABEL "R" |  | 2PCS |
| C | LEG WITH LABEL "L" |  | 2PCS |
| D | CENTER SUPPORT LEG WITH LEVELER |  | 1PC |

HARDWARE IDENTIFICATION

| | | | |
|---|--------------------------------------|---|------|
| 1 | BOLT (M6 x 35mm - BLK) |  | 4PCS |
| 2 | LOCK WASHER (1/4" - BLK) |  | 4PCS |
| 3 | FLAT WASHER (1/4"ID x 19mm - BLK) |  | 4PCS |
| 4 | WOOD DOWEL (8 x 20mm) |  | 4PCS |
| 5 | ALLEN WRENCH (M4 x 60mm - BLK) |  | 1PC |

NOTE:

Phillips head screw driver is required in the assembly process; however, manufacturer does not provide this item.

ASSEMBLY INSTRUCTIONS

STEP 1

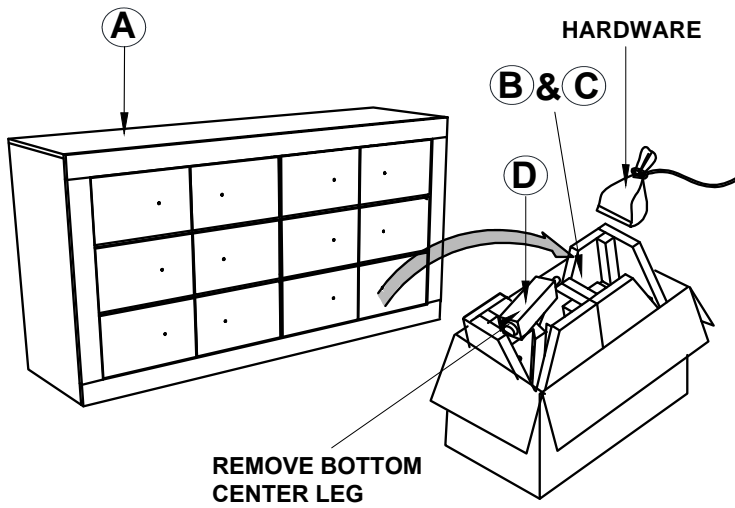

STEP 2

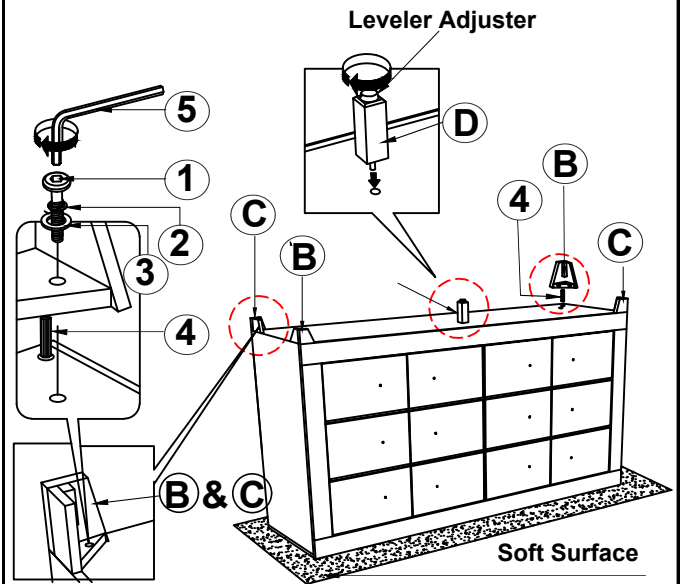

STEP 3

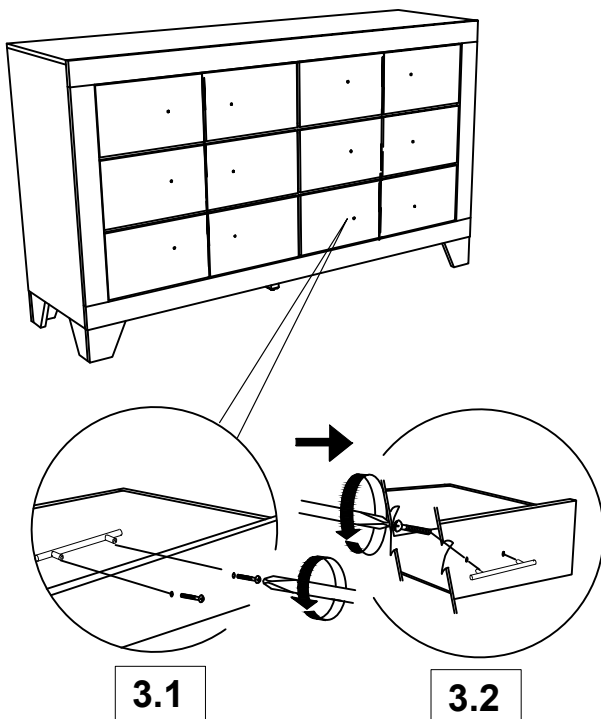

STEP 4 **COMPLETE**



Inner Size of Drawer : 23.25"W x 11.25"D x 5.25"H x 0.25"T

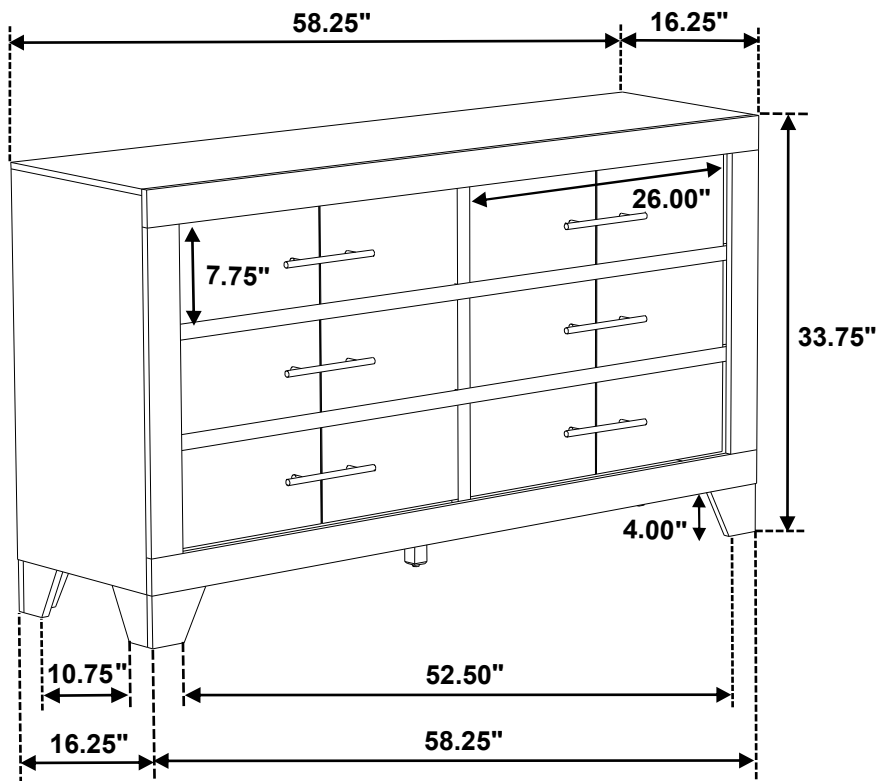

Note : Dimension tolerance $\pm 5\%$

ASSEMBLY INSTRUCTIONS



Fine Furniture for every stage of life

Mirror

REVISION 0 : 11/23/2024
REVISION 1 : 06/18/2025

ASSEMBLY INSTRUCTIONS

ASSEMBLY TIPS:

1. Remove hardware from box and sort by size.
2. Please check to see that all hardware and parts are present prior to start of assembly.
3. Please follow attached instructions in the same sequence as numbered to assure fast & easy assembly.



WARNING!

1. Don't attempt to repair or modify parts that are broken or defective. Please contact the store immediately.
2. This product is for home use only and not intended for commercial establishments.



ASSEMBLY TIME

10 MINUTES

PARTS IDENTIFICATION

A MIRROR

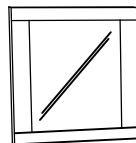

1PC

B DRESSER



1PC

C MIRROR SUPPORT
(PACK WITH DRESSER)



2PCS

HARDWARE IDENTIFICATION

1 FLAT HEAD SCREW
(M4 x 32mm - RBW)



10PCS

NOTE:

Phillips head screw driver is required in the assembly process; however, manufacturer does not provide this item.

ASSEMBLY INSTRUCTIONS

STEP 1

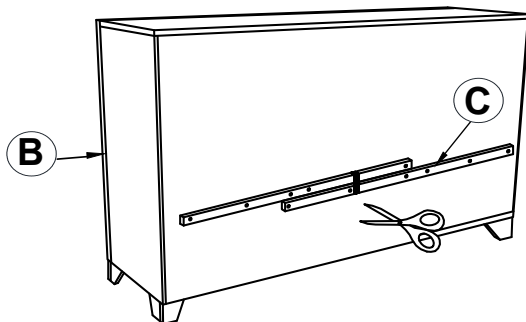

****BACK VIEW****

STEP 2

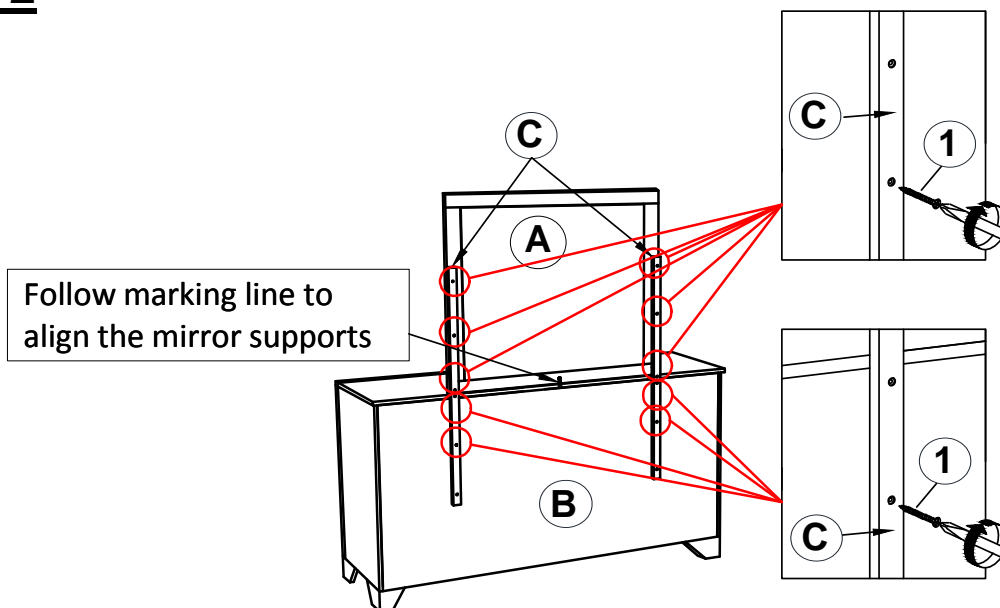

STEP 3 **COMPLETE**



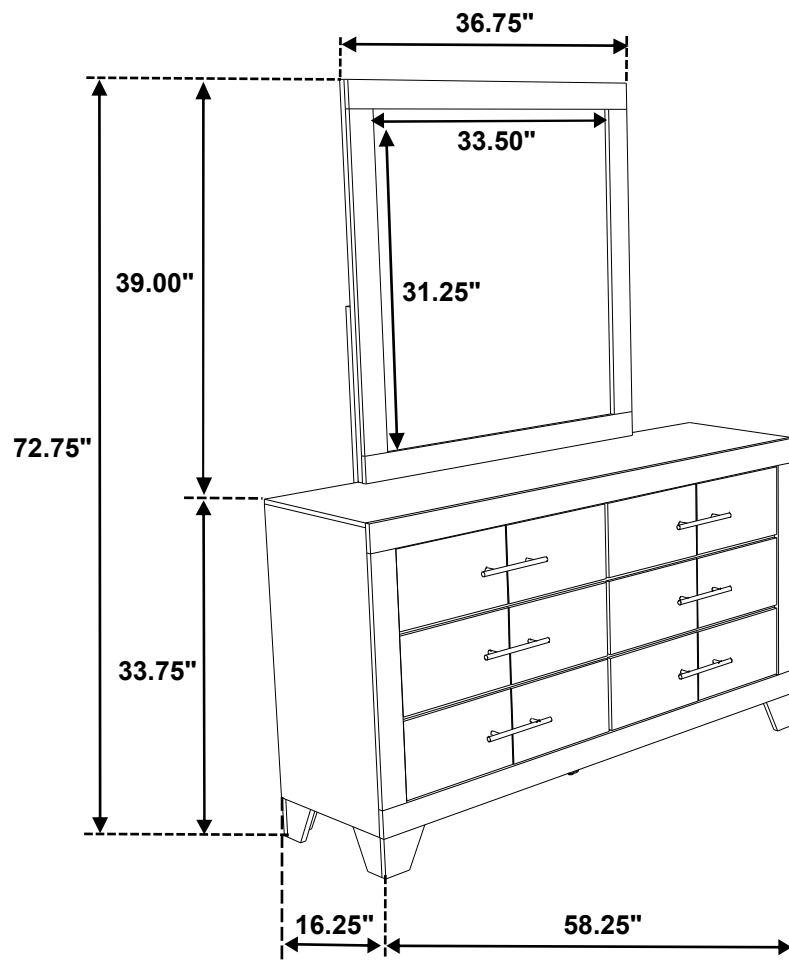

Note : Dimension tolerance $\pm 5\%$