



# **Thank you for shopping from us!**

In order to enable you to better install or use this product, please carefully review the precautions and detailed functional operation instructions provided in this manual before using this product formally.

**Hope you have a positive experience with it!**

## **Assembly Guide**

**The assembly guide includes a Part List, Installation Steps, and Warning Tips.**

Please note that your item may arrive in multiple packages to facilitate transportation, and it's important to check all packages once you receive them. If any questions or concern regarding the product, please don't hesitate to reach out to our customer

# Parts List

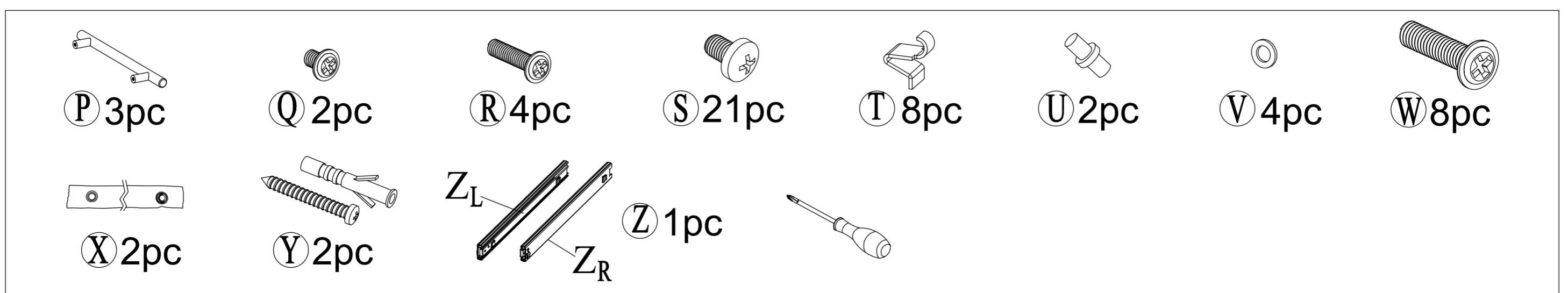
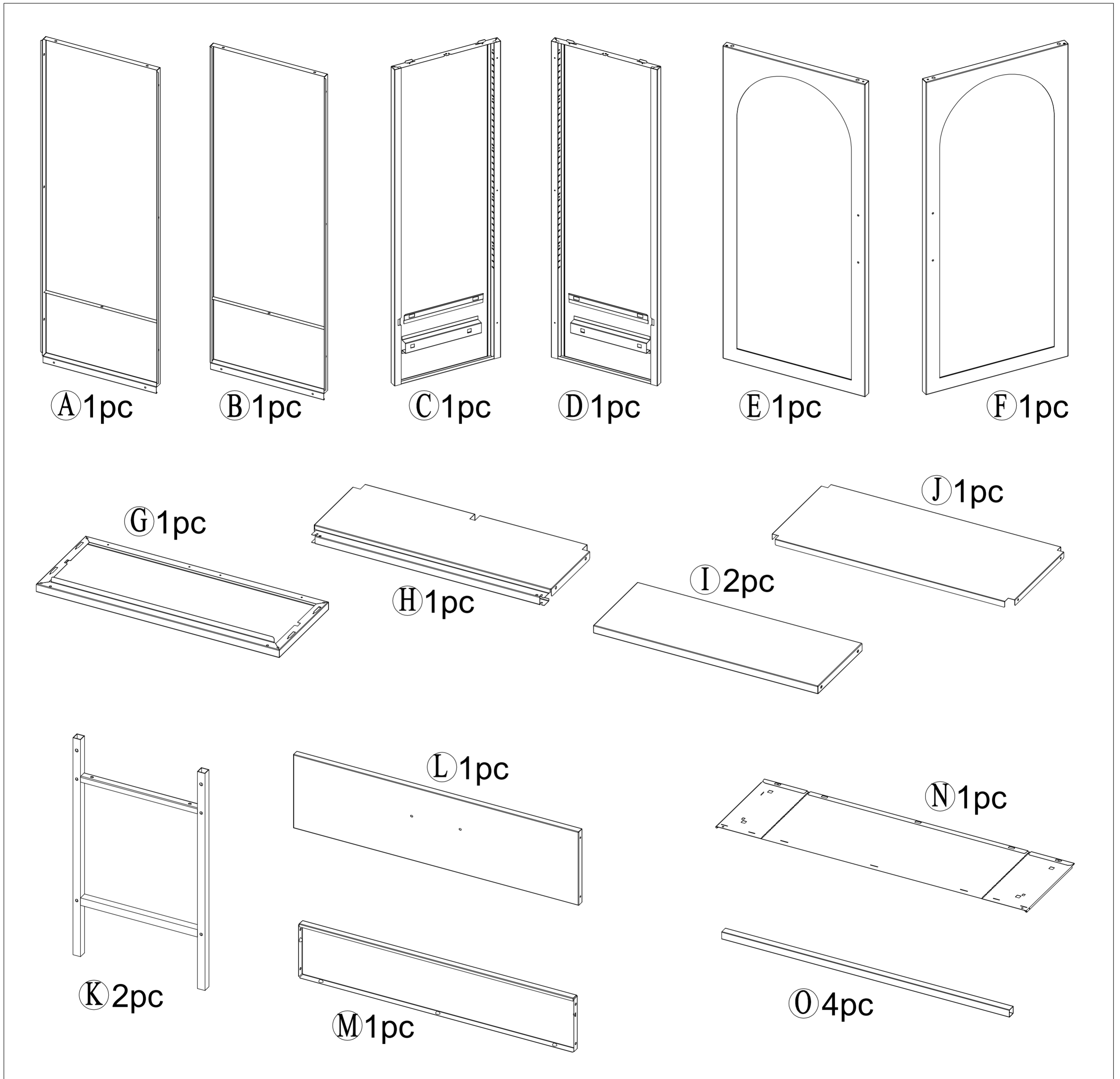

# Installation Steps

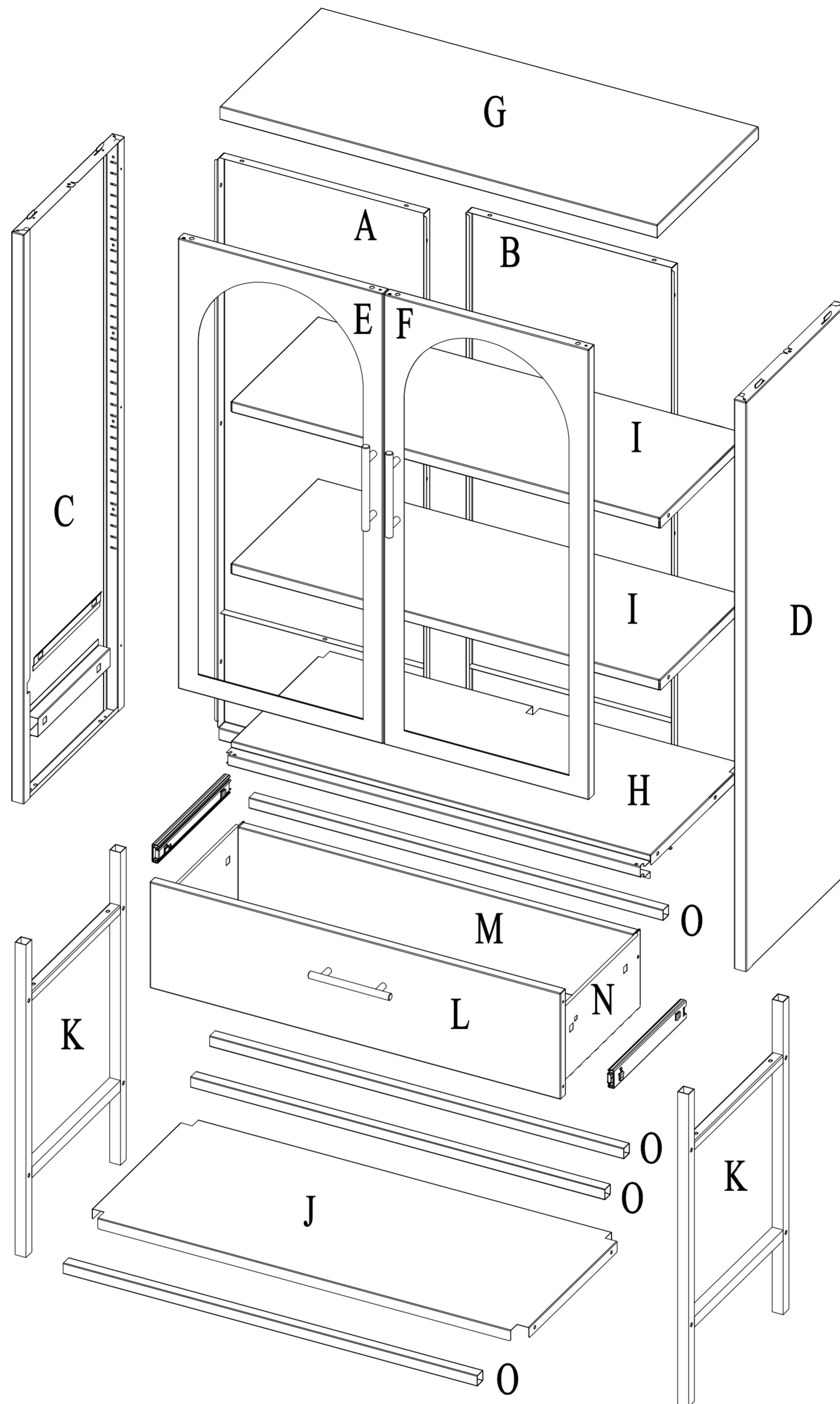

## Checking

Before starting the installation process, please check that all parts are present and undamaged.

Ensure that the parts and quantities in the pack age correspond with the Part List. If there are any mistakes or missing parts, kindly contact us through the purchase platform for assistance.

# STEP 1

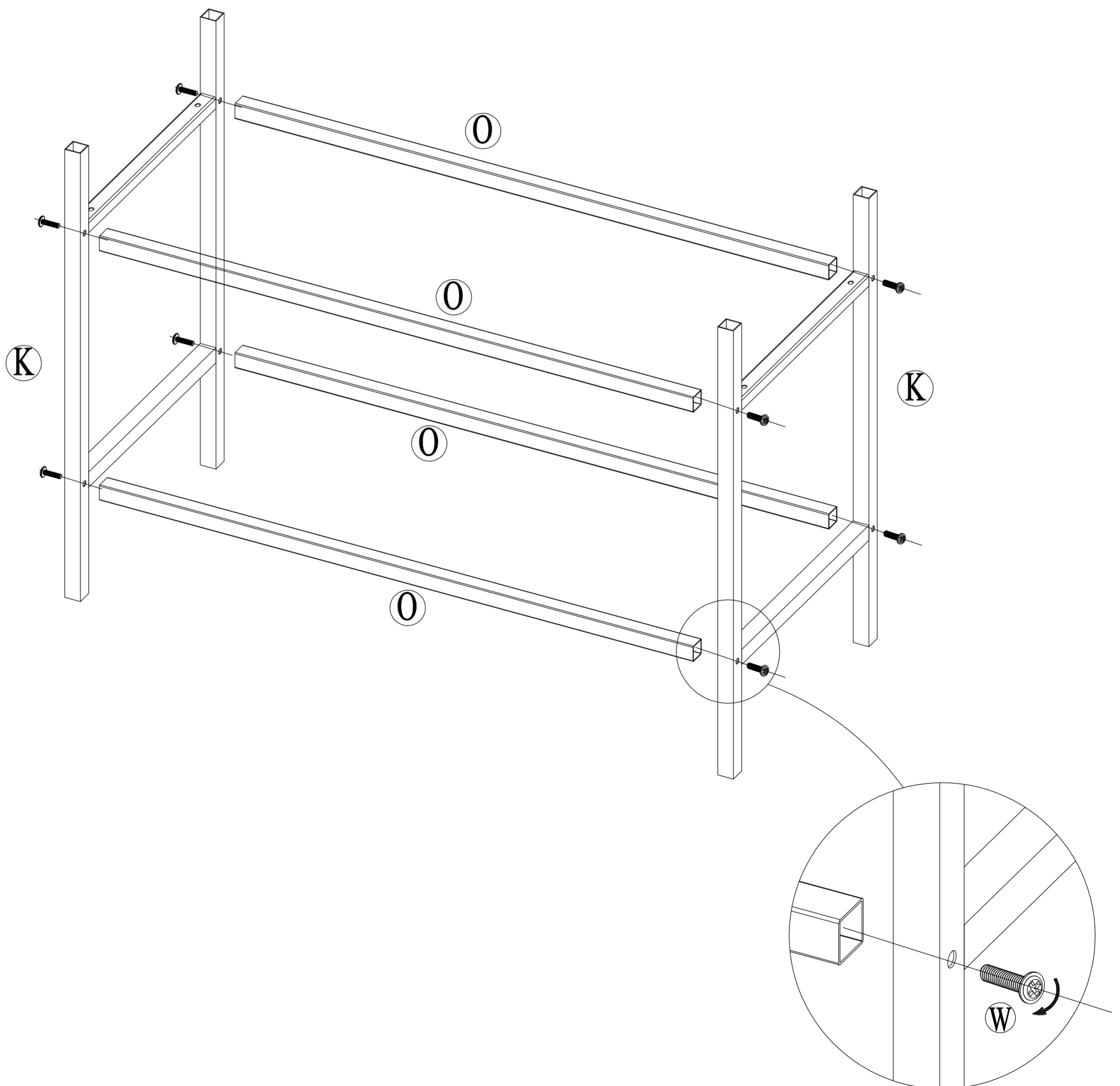
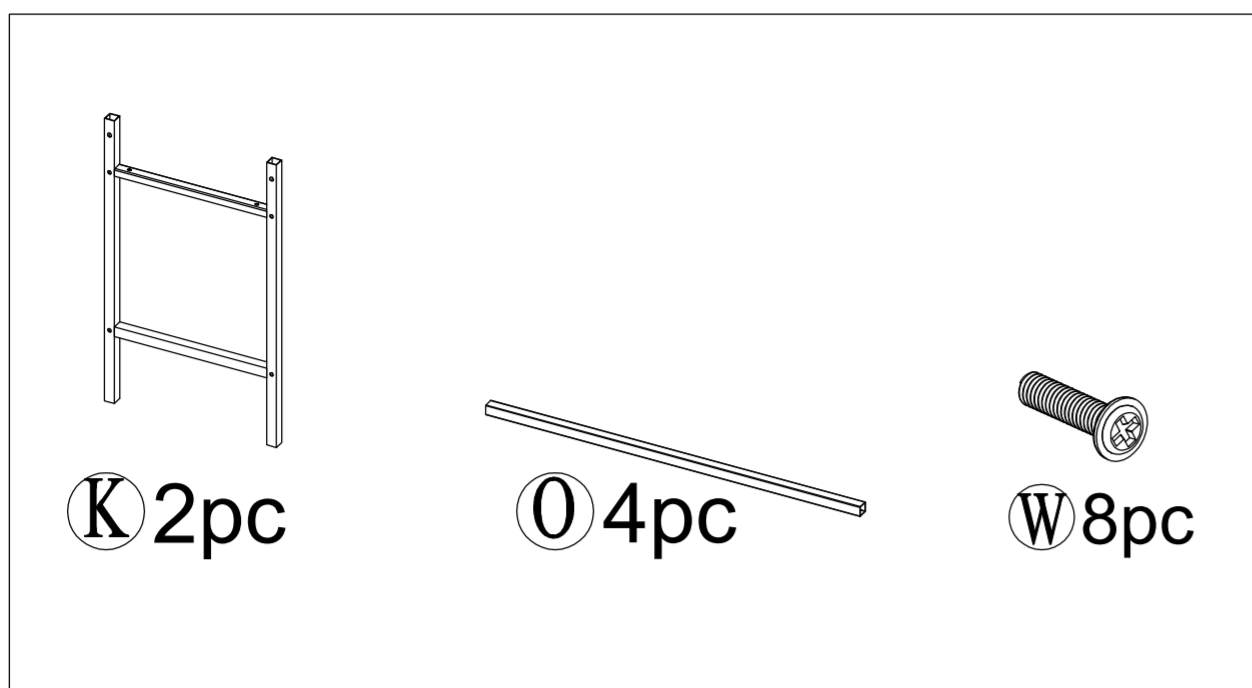

## STEP 2

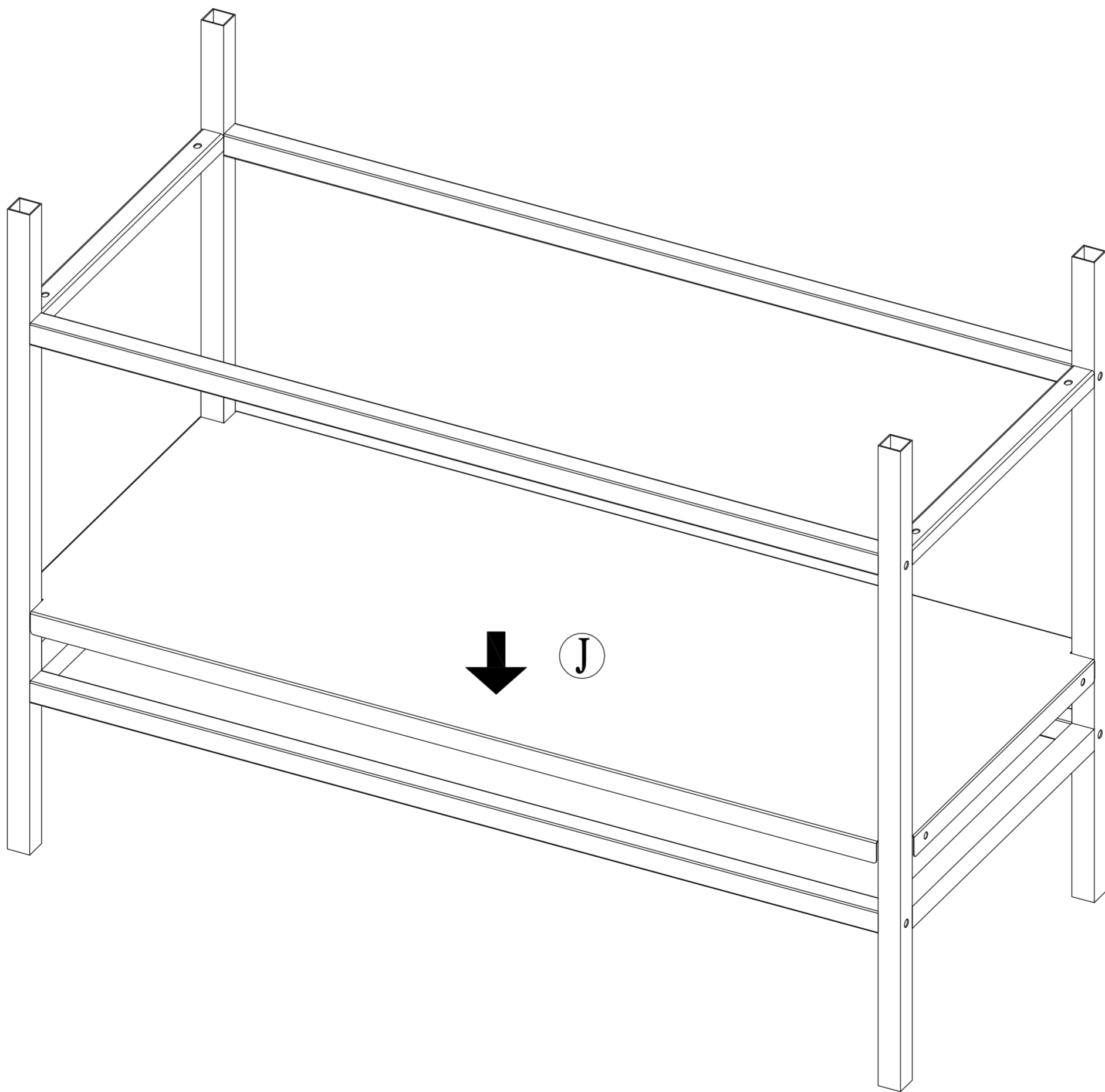
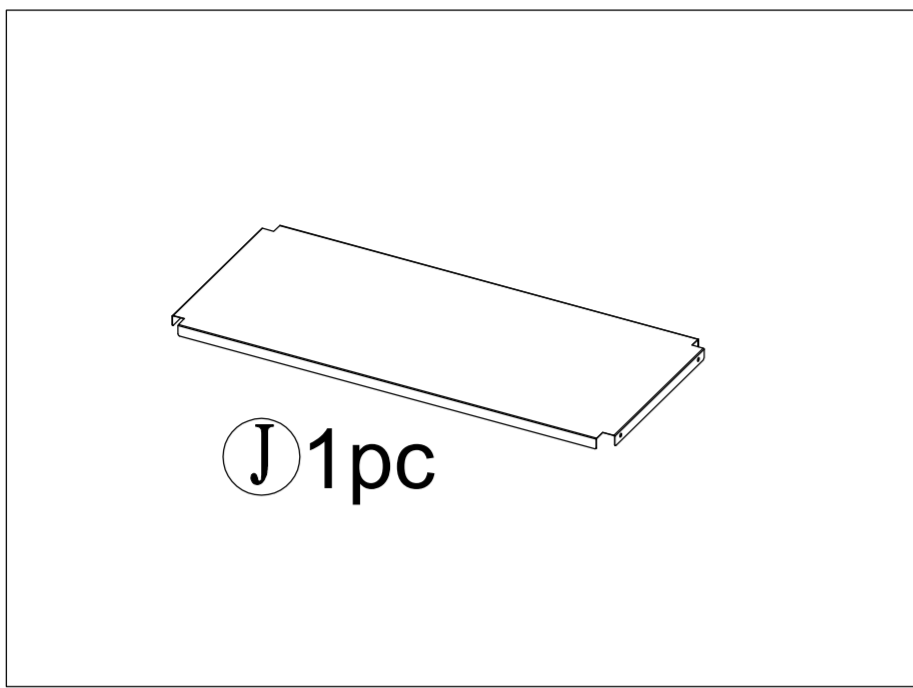

# STEP 3

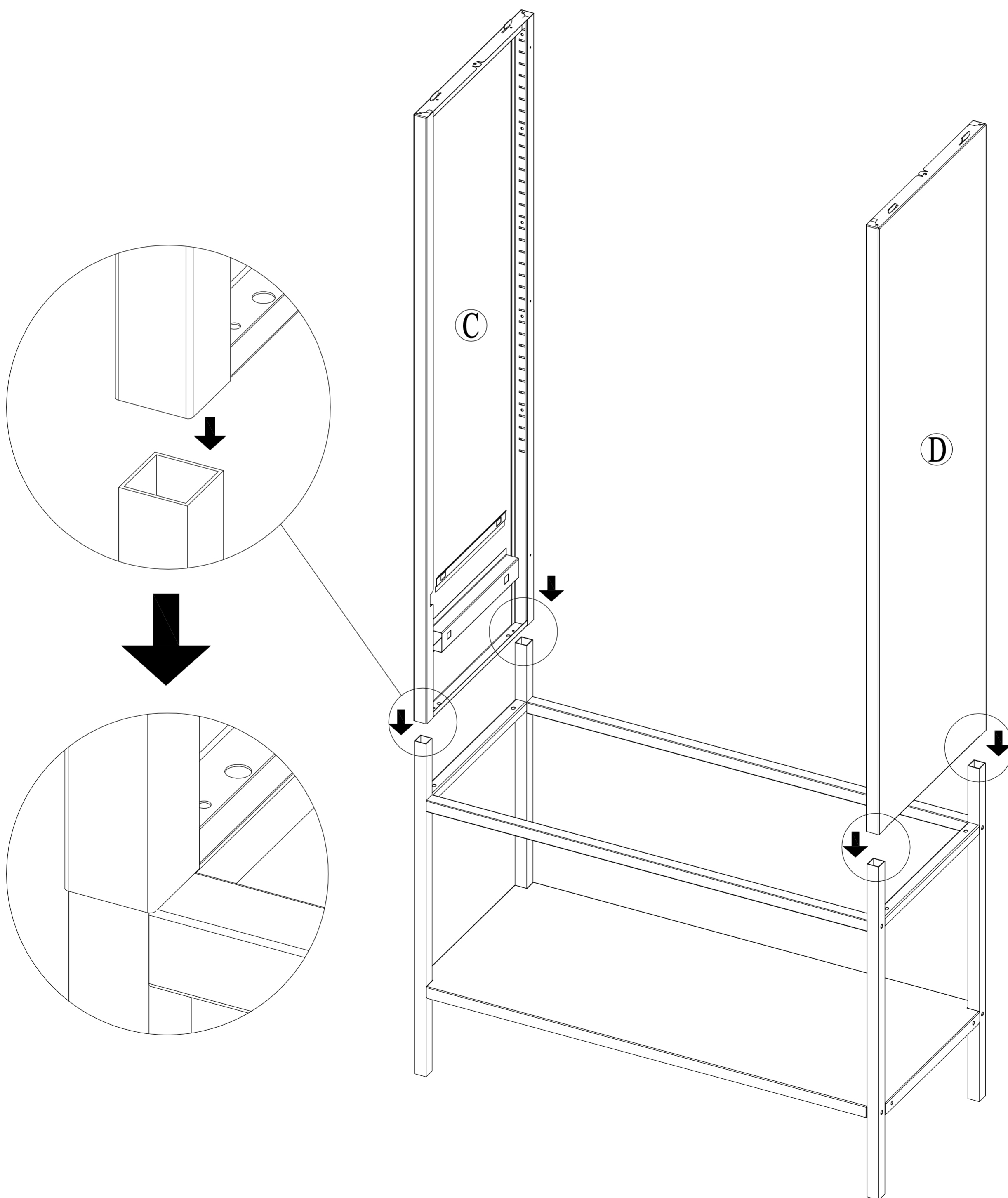
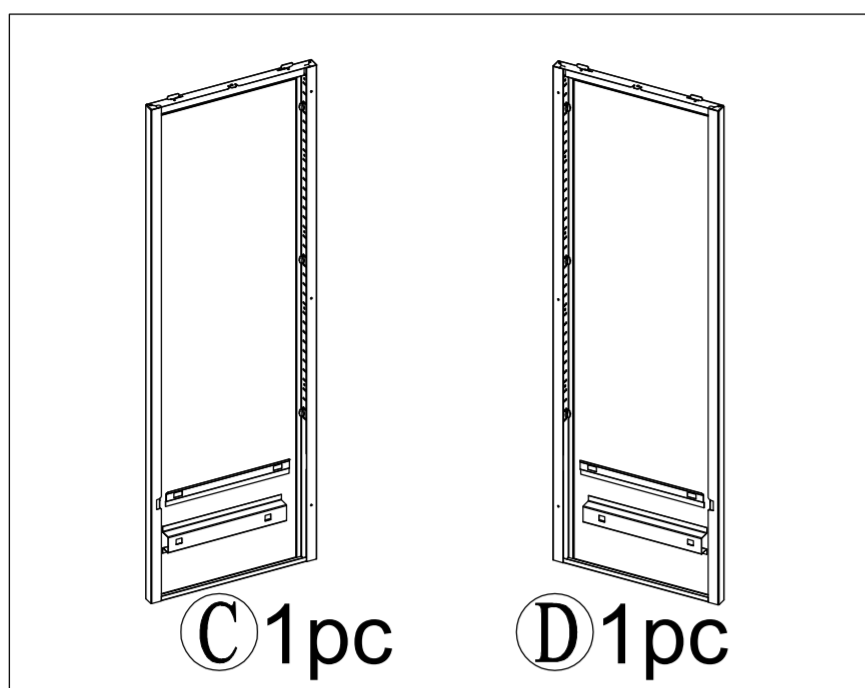

# STEP 4

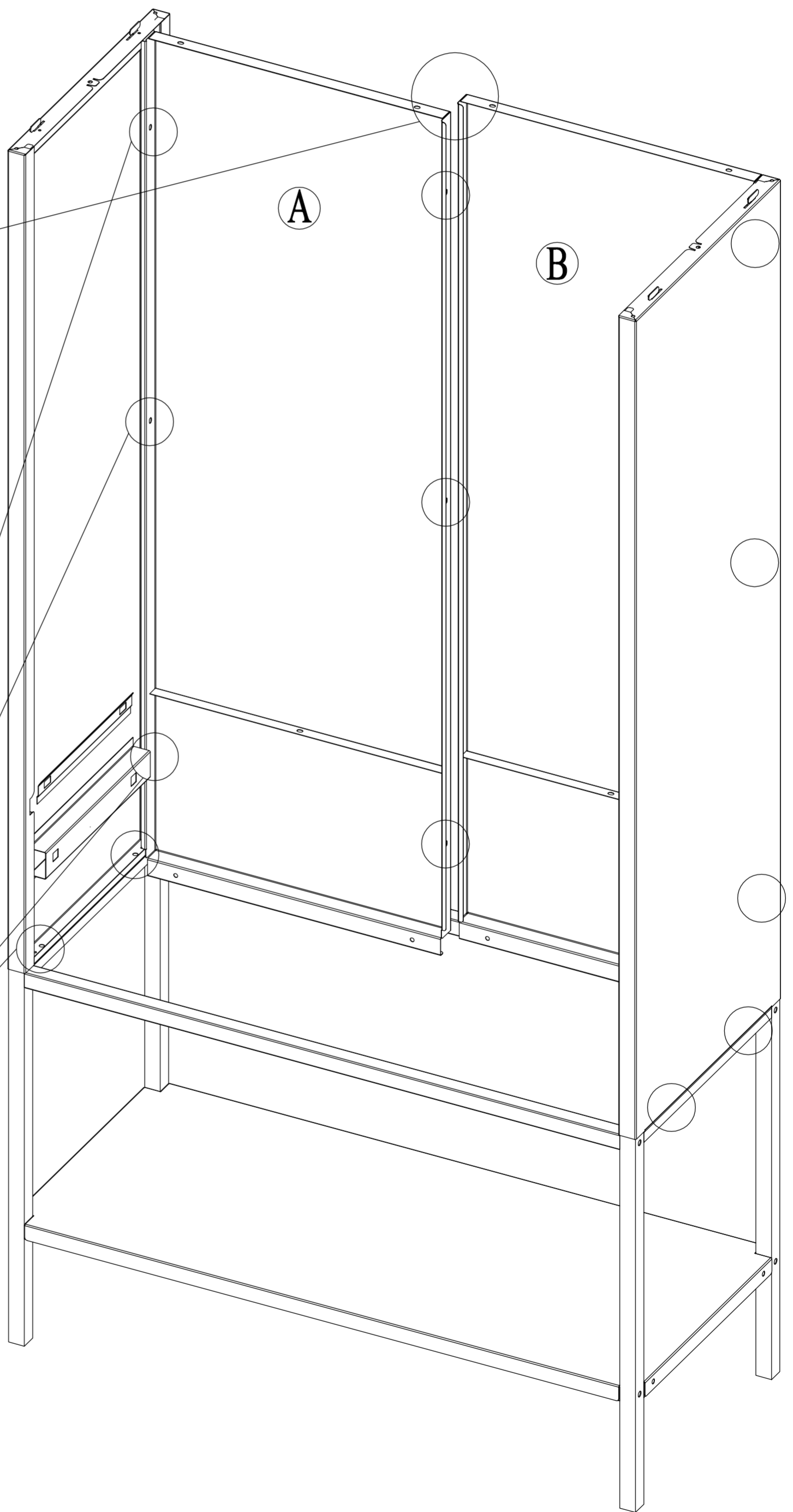
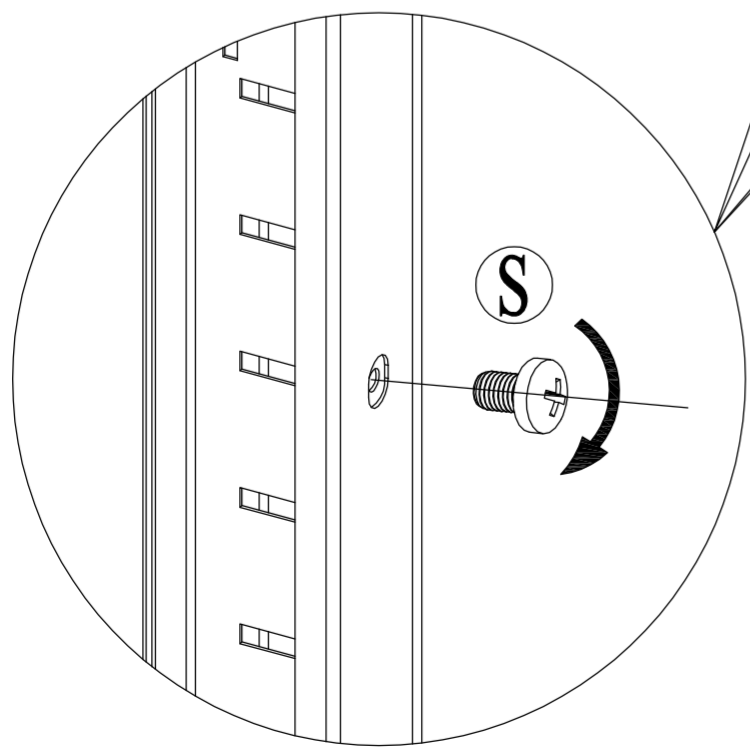
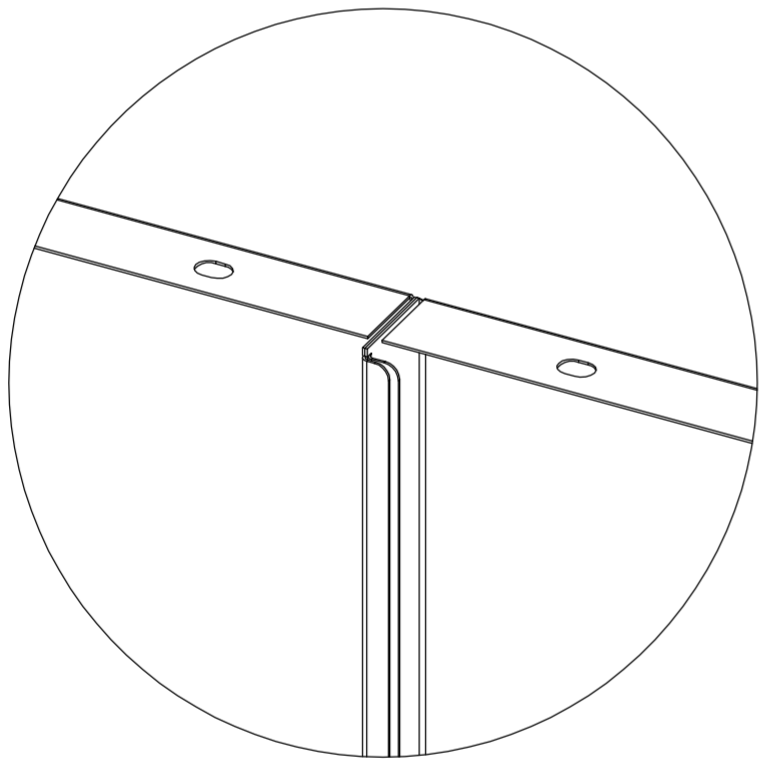
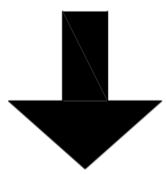
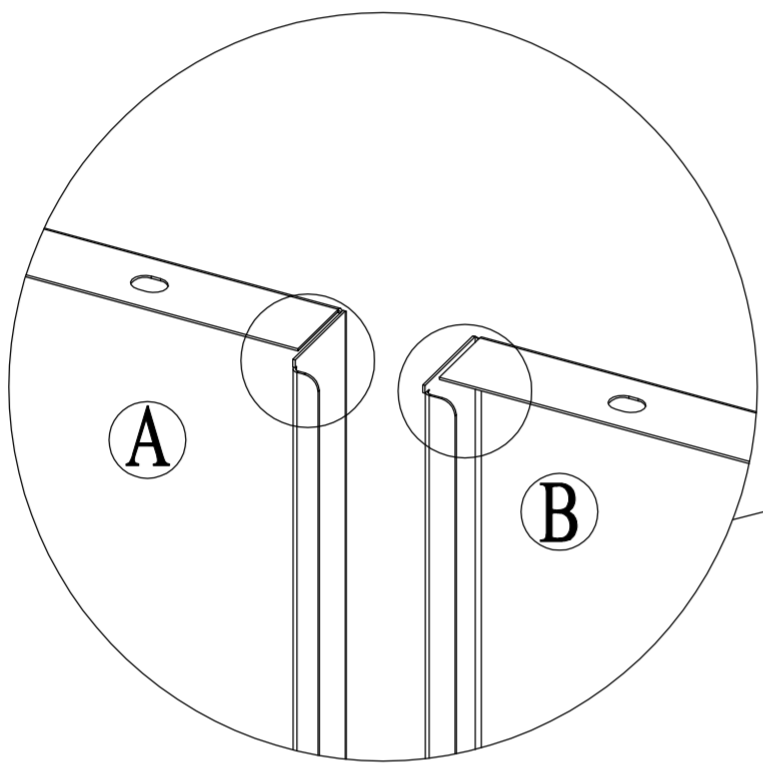
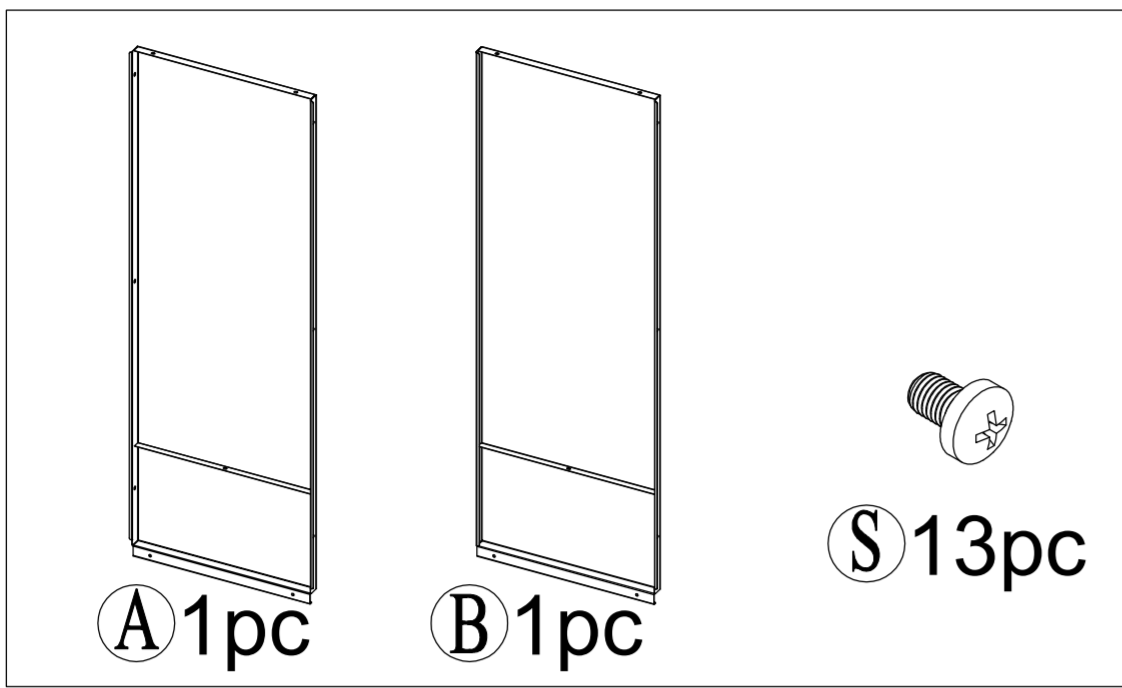

# STEP 5

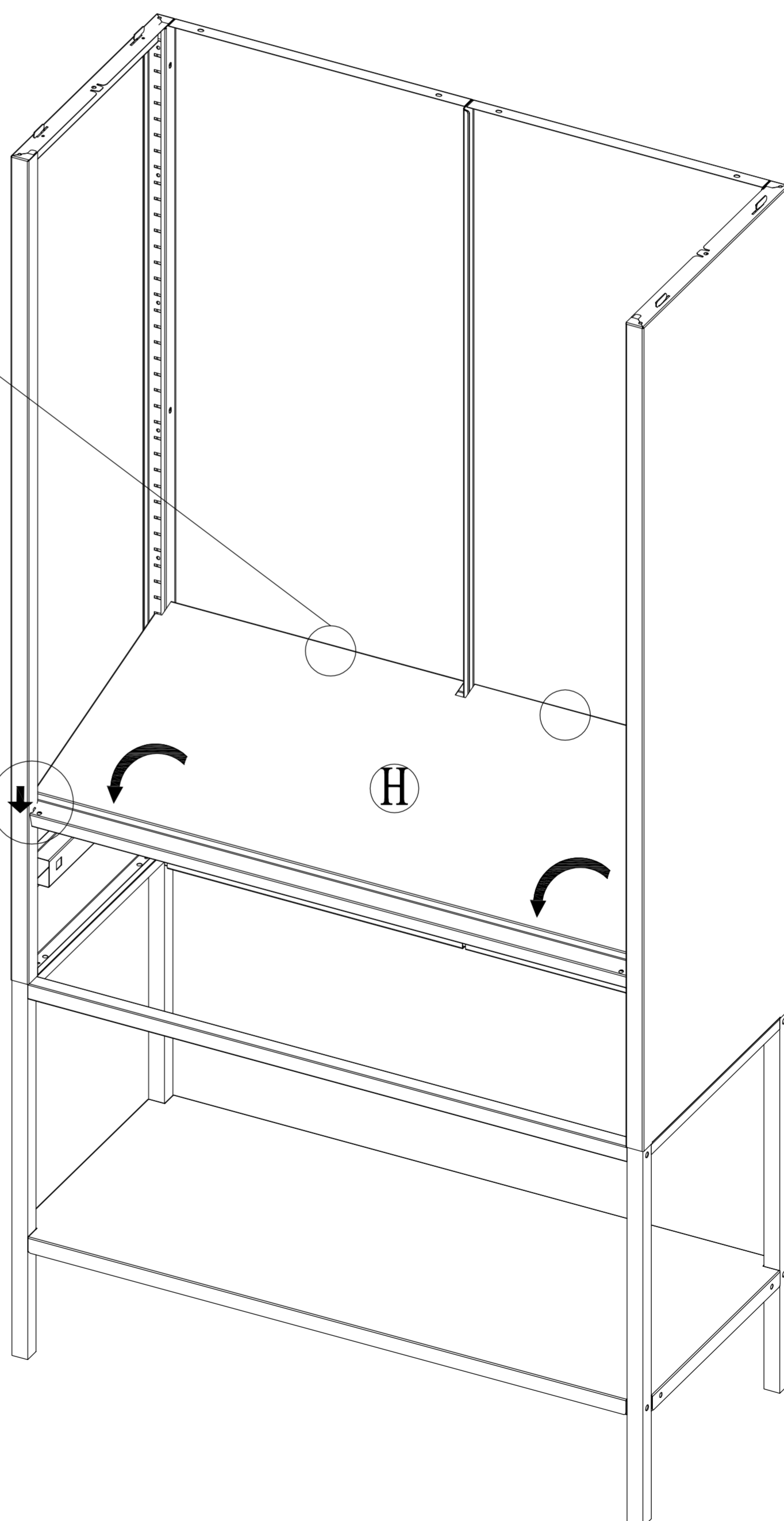
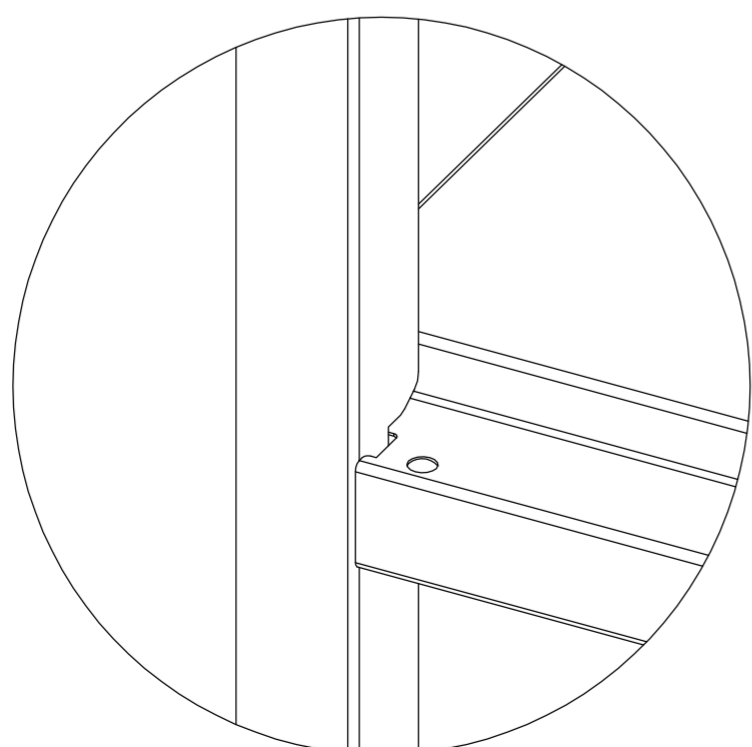
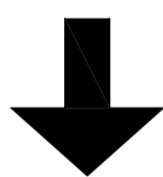
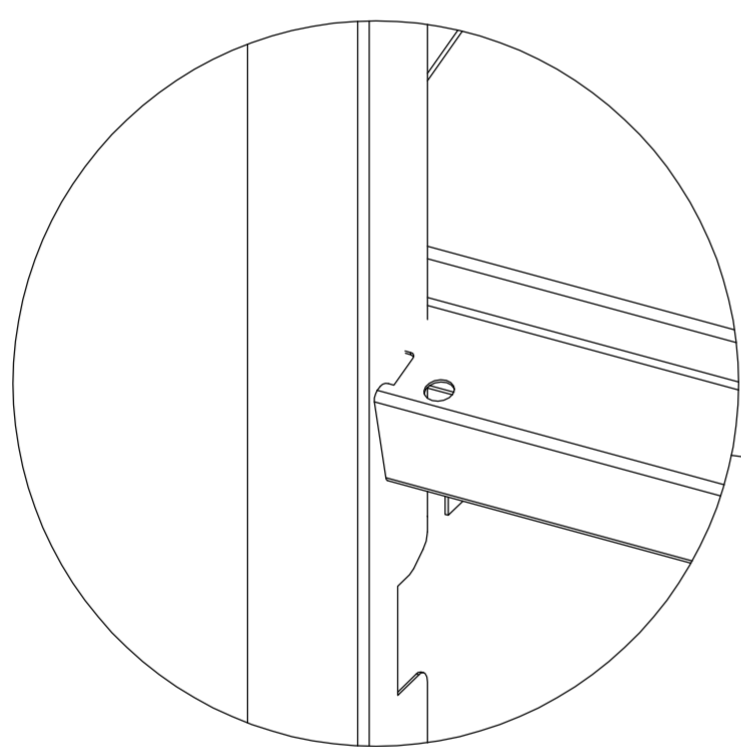
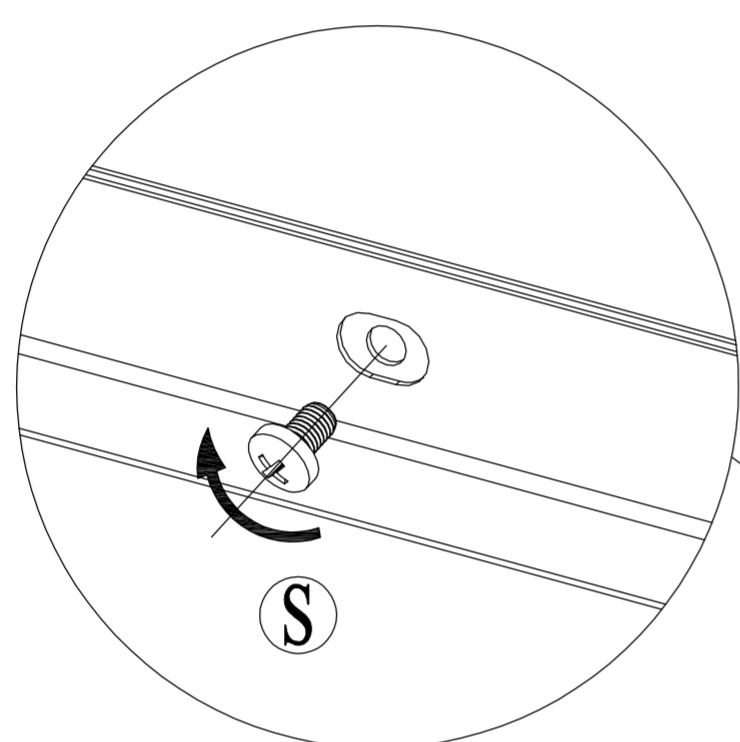
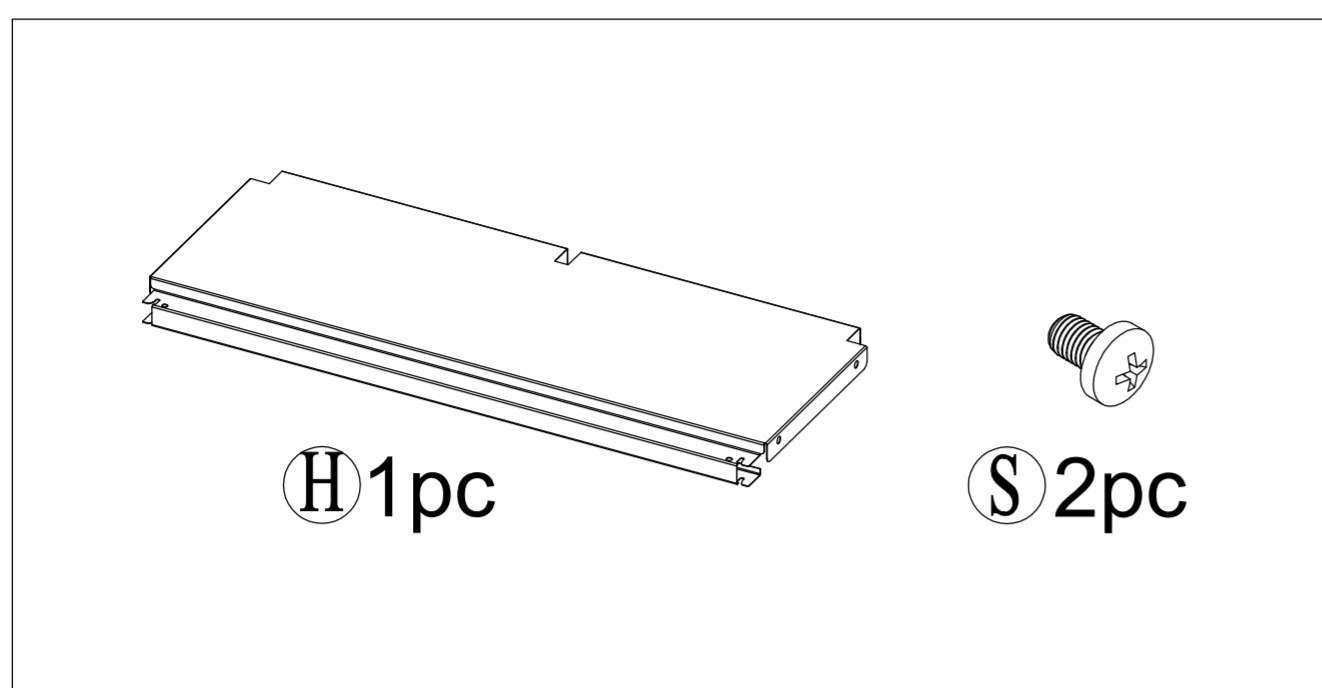

# STEP 6

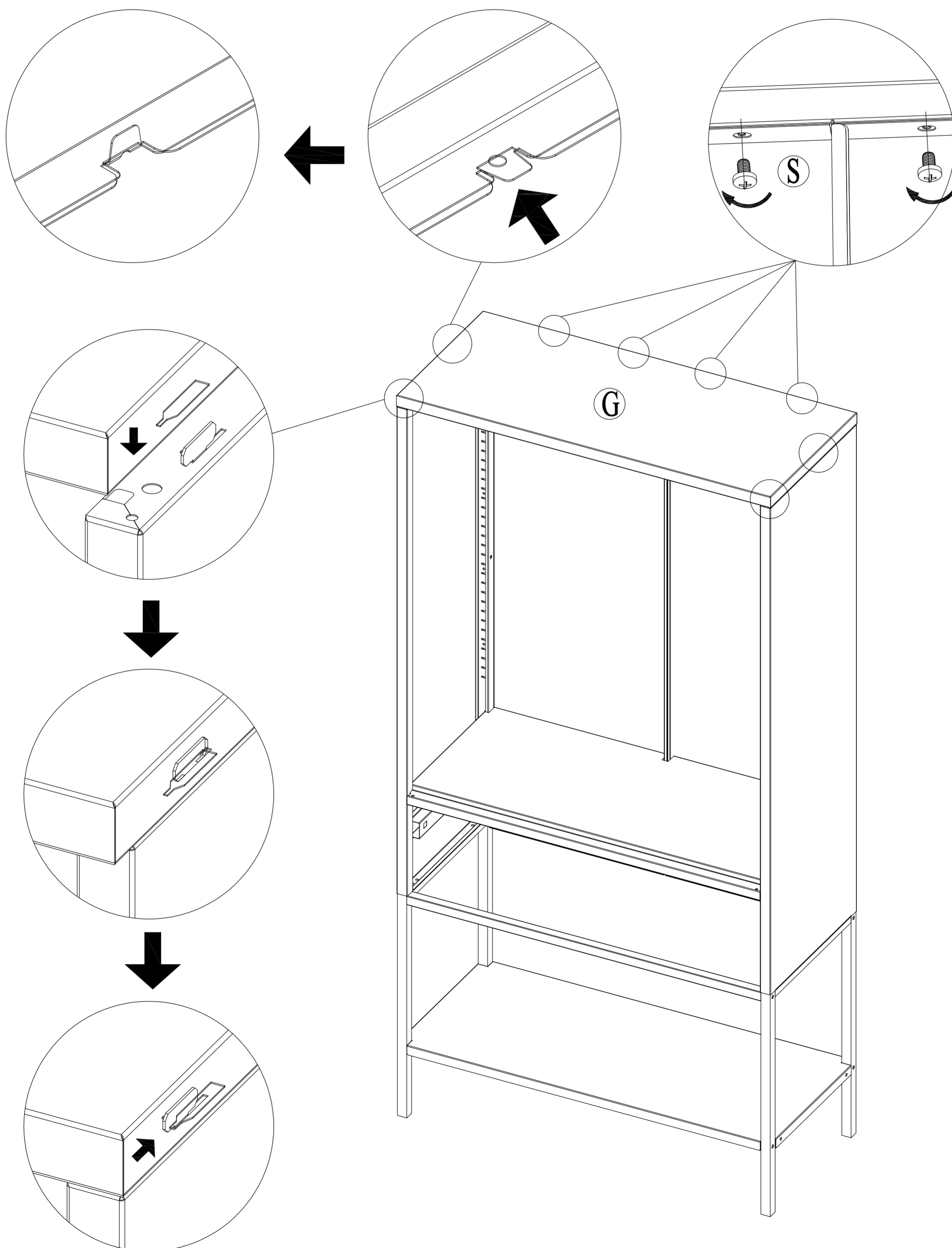
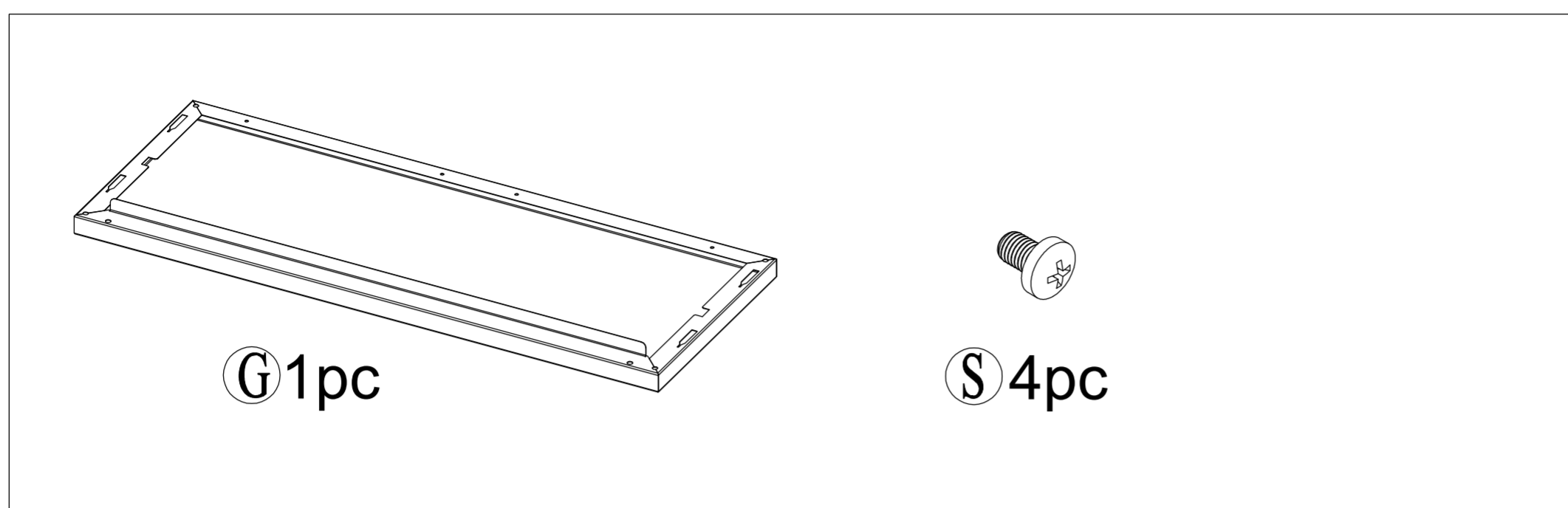

# STEP 7

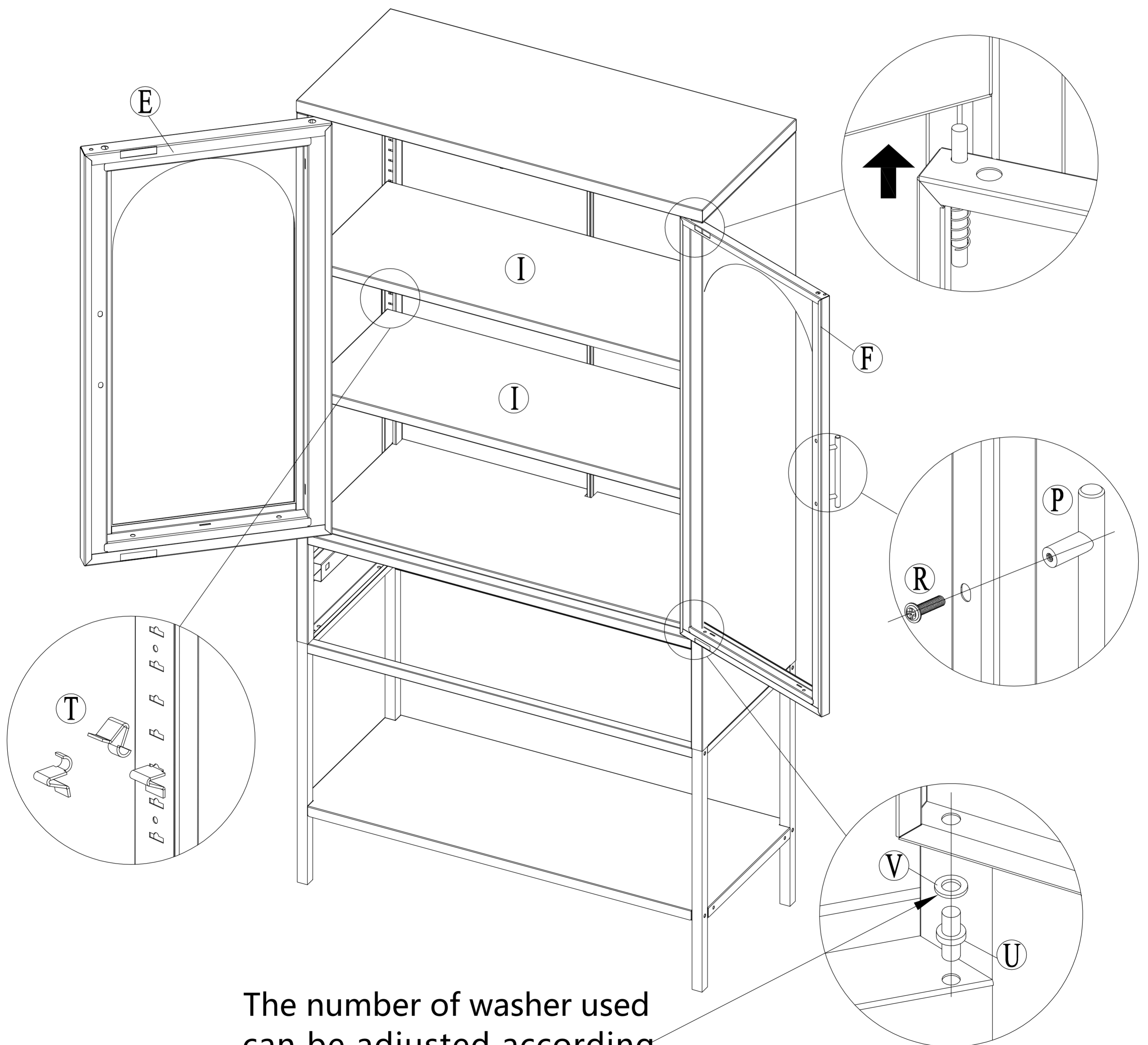
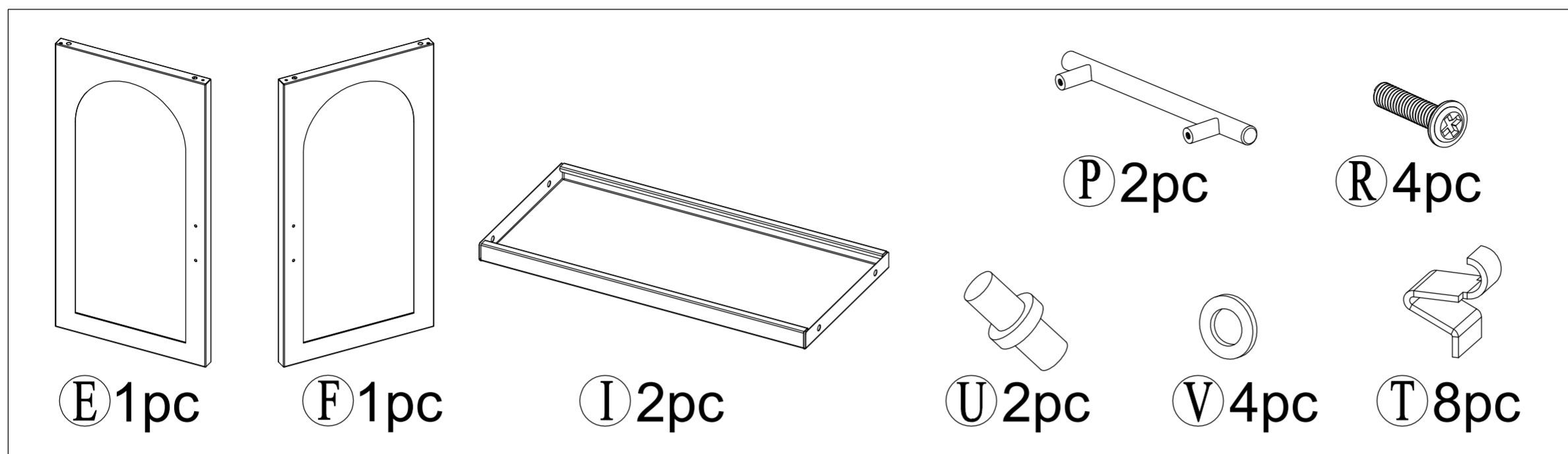

The number of washer used can be adjusted according to the actual situation

# STEP 8

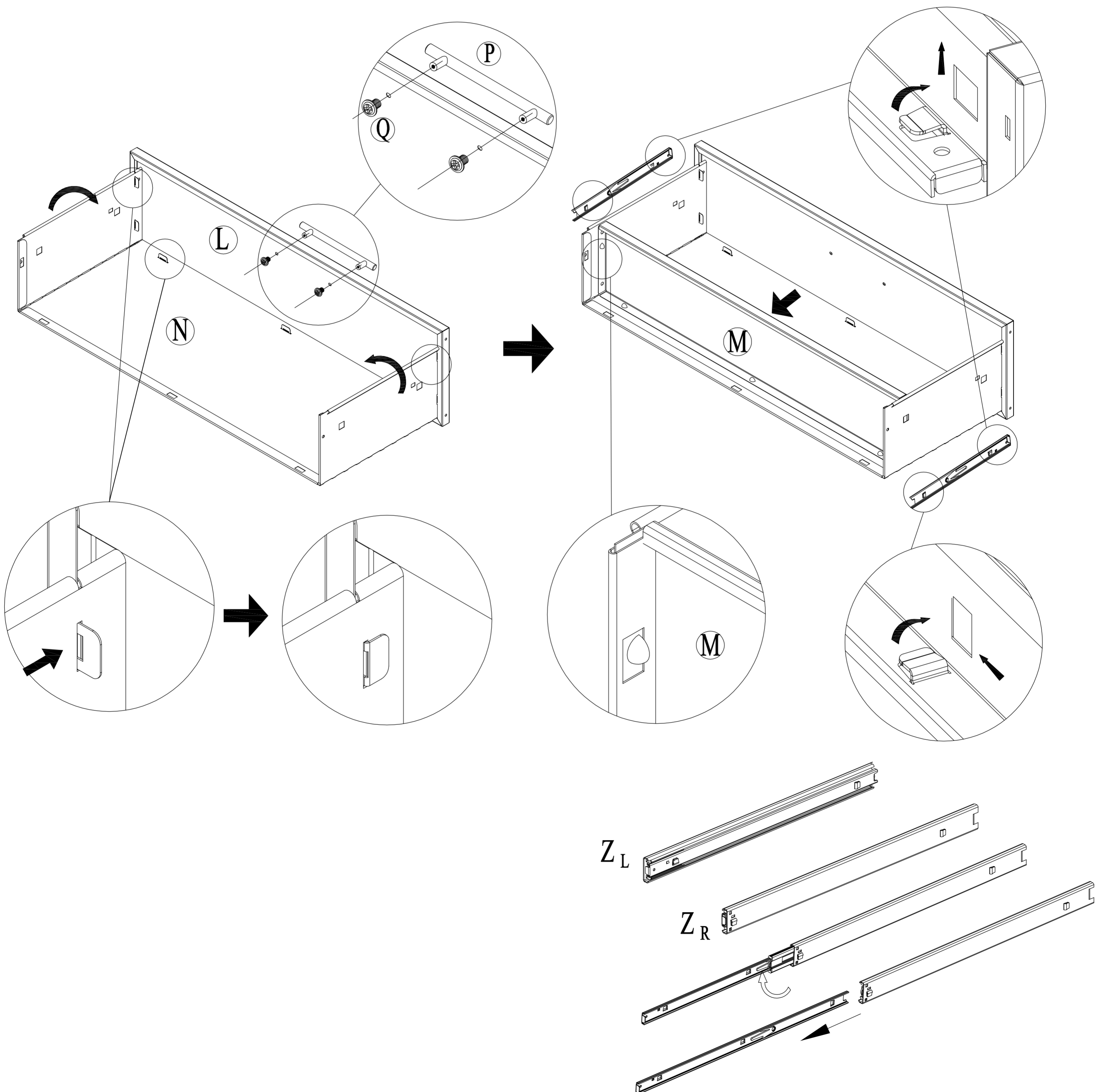
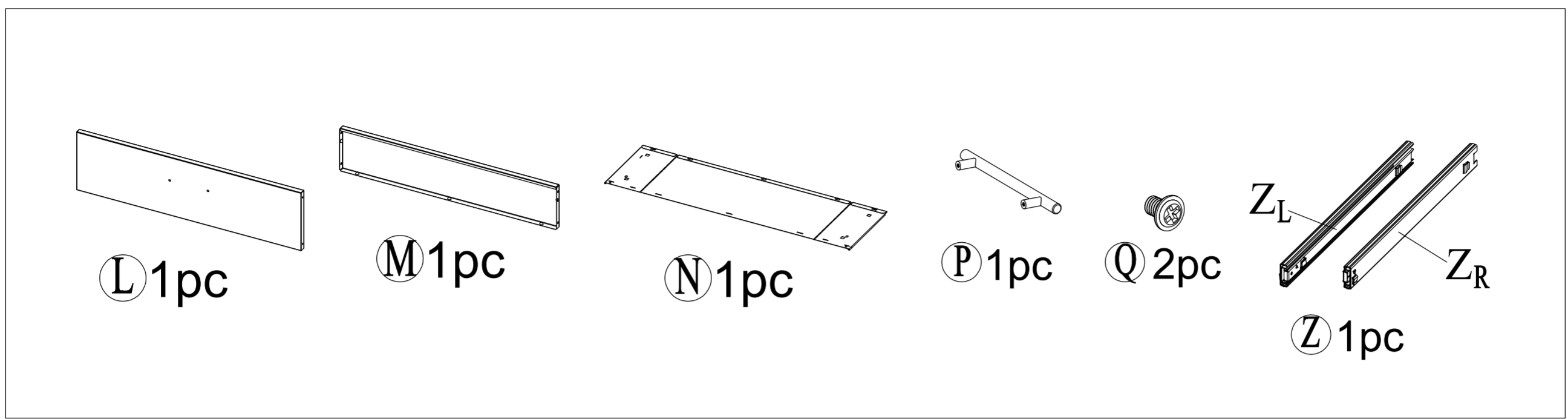

# STEP 9

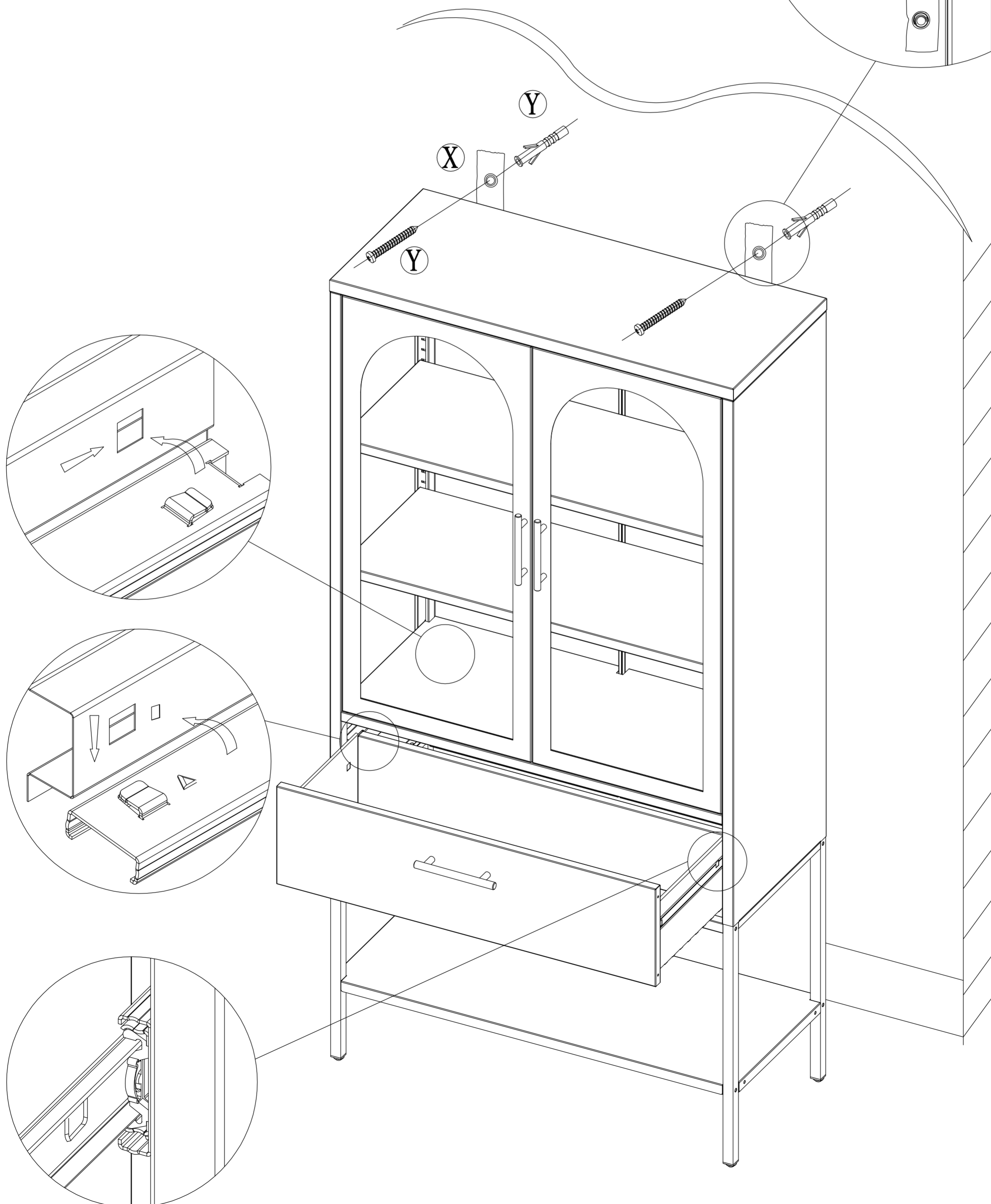
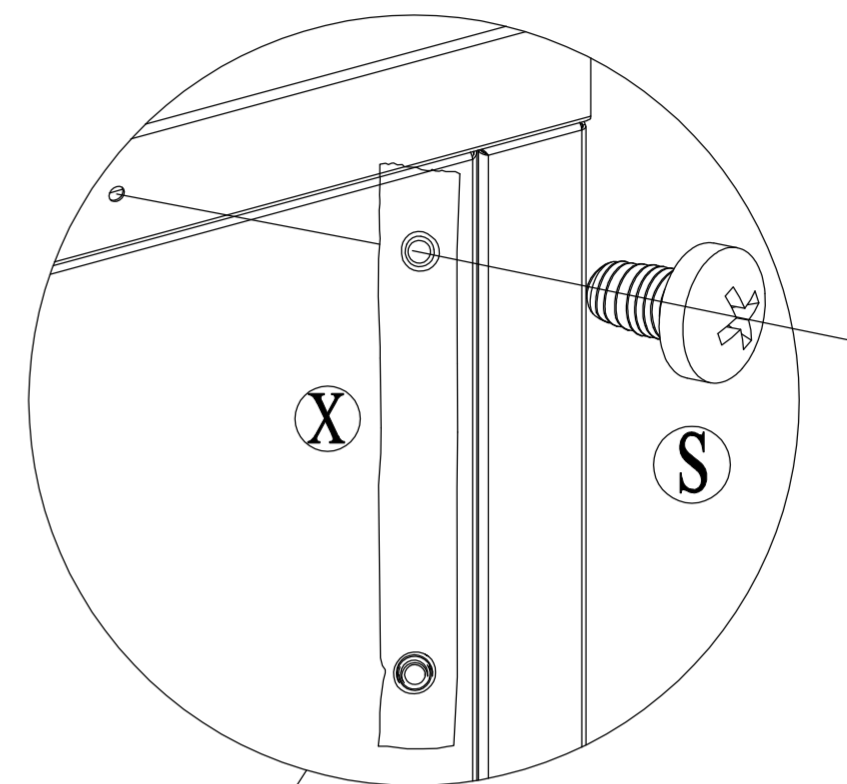
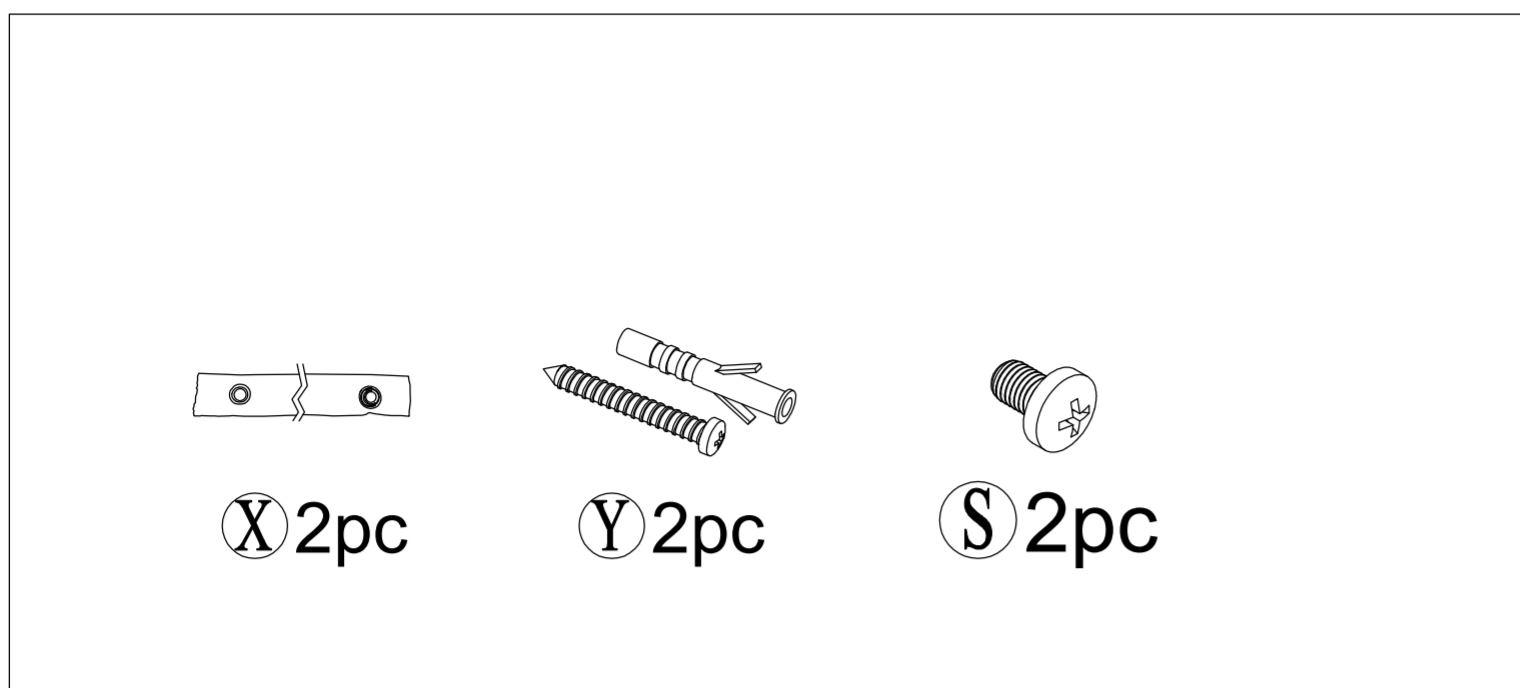

## STEP 10

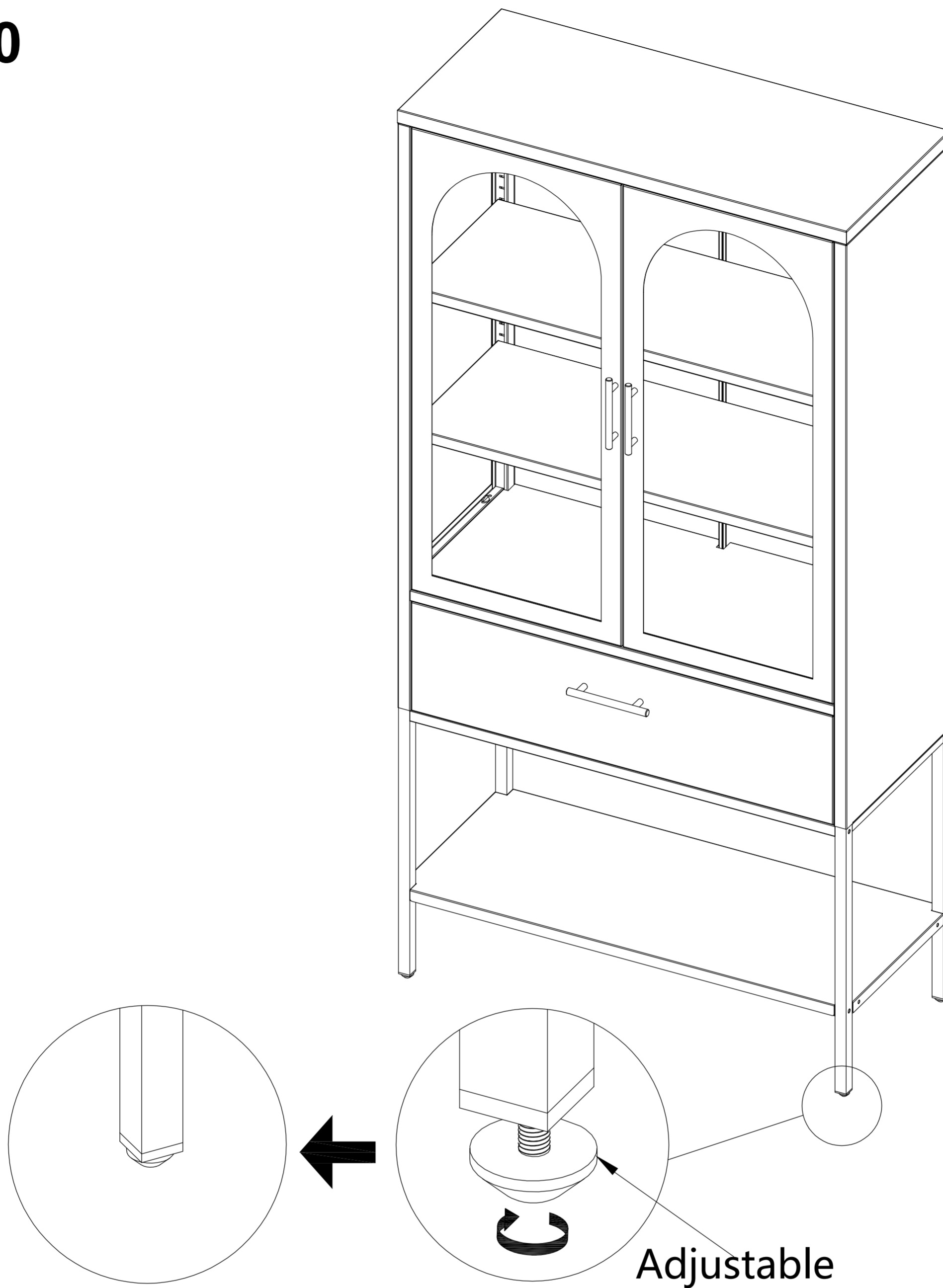

## Security/ Notice

- To ensure safe installation and use of this product, please follow these security notices:
- During initial assembly, fasten screws loosely and avoid firmly tightening them until the item is fully assembled.
  - Some parts of the product may be heavy and have sharp edges. Please handle with care.
  - Stop using this item immediately if any parts are missing, broken, damaged, or worn, until repairs are made or factory replacement parts are installed.
  - Reconfirm that all bolts, screws, and knobs are securely fastened every 90 days.
  - Avoid using this item in a way inconsistent with the manufacturer's instructions, as this could void the product warranty.

# Warranty Guidelines

**.We offer a limited warranty period that begins on the date of shipment from Walsport for factory direct purchases, or on the date of purchase from an authorized reseller. Please keep a copy of your purchase receipt.**

**·If this product or any associated parts are found to be defective or missing at the time of receipt, Walsport will repair or replace the defective parts at no charge to the original purchaser. Replacement parts or repaired parts shall be covered for the remainder of the Original Limited Warranty Period.All shipping costs will be the responsibility of the seller.**

**·We provide continuous free technical support, including online diagnosis and troubleshooting to help solve any issues that arise. To process your warranty claim, please upload a copy of your receipt along with AT LEAST 2 photos of the issue/damaged parts. Failure to do so may result in the supplier refusing replacement parts or credit.**

**.If a warranty claim is made 30 days after purchase for missing or defective parts, the consumer is responsible for the costs of parts and shipping.**

**·Walsport reserves the right to the final explanation of the above warranty policy.Please contact our customer service team via email at for more information. What is not covered by this limited warranty?.Item past the warranty.**

**.Products that have been subjected to abuse, obesity, accident, alteration,modification, tampering, vandalism, negligence, misuse, abrasive contact, faulty installation or lack of reasonable care.**

**.Damage to the contents of products, any person or property is excluded. Normal and foreseeable service wear or tear.**

**.Parts were damaged due to improperinstallation or assembly.**

**.Damage that occurs due to acts of nature, i.e. hurricane, tornado, wind, flood, snow, wind driven debris, etc.**

**·Third party labor or installation fees of any kind are not recoverable under the warranty. Other circumstances are stipulated by law.**