

ASSEMBLY INSTRUCTION

Thank you for purchasing this quality product. Be sure to check all packing material carefully for small parts which may have come loose inside the carton during shipment. Separate, identify and count all parts and hardware. Compare with the parts list to be sure all parts are present.

IMPORTANT : PLEASE READ INSTRUCTION BEFORE STARTING THE ASSEMBLY.

"DO NOT TIGHTEN SCREWS UNTIL COMPLETELY ASSEMBLED"

"DO NOT OVERTIGHT ANY HARDWARE"

WARNING : SMALL PARTS AND HARDWARE NOT FOR CHILDREN UNDER 3 YEARS. ADULT ASSEMBLY REQUIRED.

TABLE OF CONTENTS

HARDWARES LIST	PAGE 2
PARTS LIST	PAGE 3
PARTS' LOCATION	PAGE 4
ASSEMBLY STEPS	PAGE 5 - 7
ASSEMBLY COMPLETED	PAGE 8

ASSEMBLY TOOLS REQUIRED

1. Screwdriver (not provide)



2. Hammer (not provide)









Skip the power drill this time.

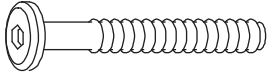
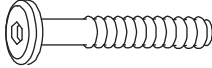
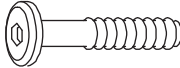
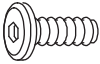

60024-311 ASSEMBLY INSTRUCTION

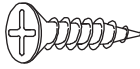
HARDWARES LIST

ITEM	DESCRIPTION	DRAWING	QTY
A	JCBC SCREW M6 x 65MM		12 PCS
B	JCBC SCREW M6 x 45 MM		12 PCS
C	JCBC SCREW M6 x 30MM		6 PCS
D	JCBC SCREW M6 x 15MM		16 PCS
E	WOOD DOWEL M8 x 30MM		8 PCS
F	SPRING WASHER M6 x 12MM		30 PCS
G	FLAT WASHER M6 x 13MM		24 PCS
H	FLAT WASHER M6 x 19MM		6 PCS
I	CSK SCREW M3.5 x 16MM		6 PCS
J	M4 ALLEN KEY (100MM)		1 PC

ASSEMBLY INSTRUCTION

PARTS LIST

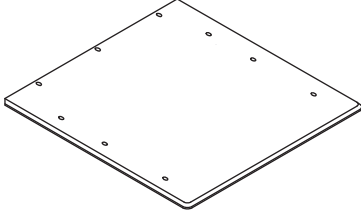
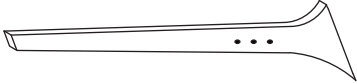
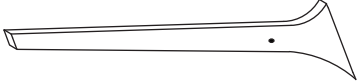
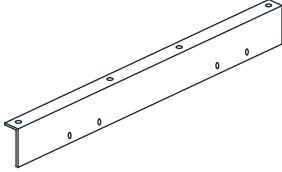
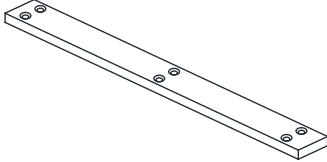
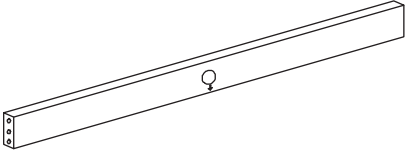
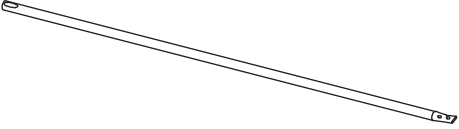
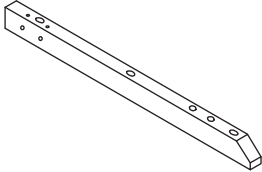
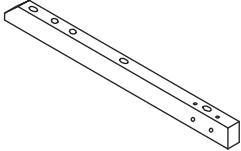
ITEM	DESCRIPTION	DRAWING	QTY
1	TABLE TOP		2 PCS
2	LEFT TABLE LEG		2 PCS
3	RIGHT TABLE LEG		2 PCS
4	METAL PLATE		2 PCS
5	CENTER SUPPORT		1 PC
6	LEG SUPPORT		2 PCS
7	METAL TUBE		2 PCS
8	LEFT APRON		2 PCS
9	RIGHT APRON		2 PCS

ASSEMBLY INSTRUCTION

PARTS ' LOCATION

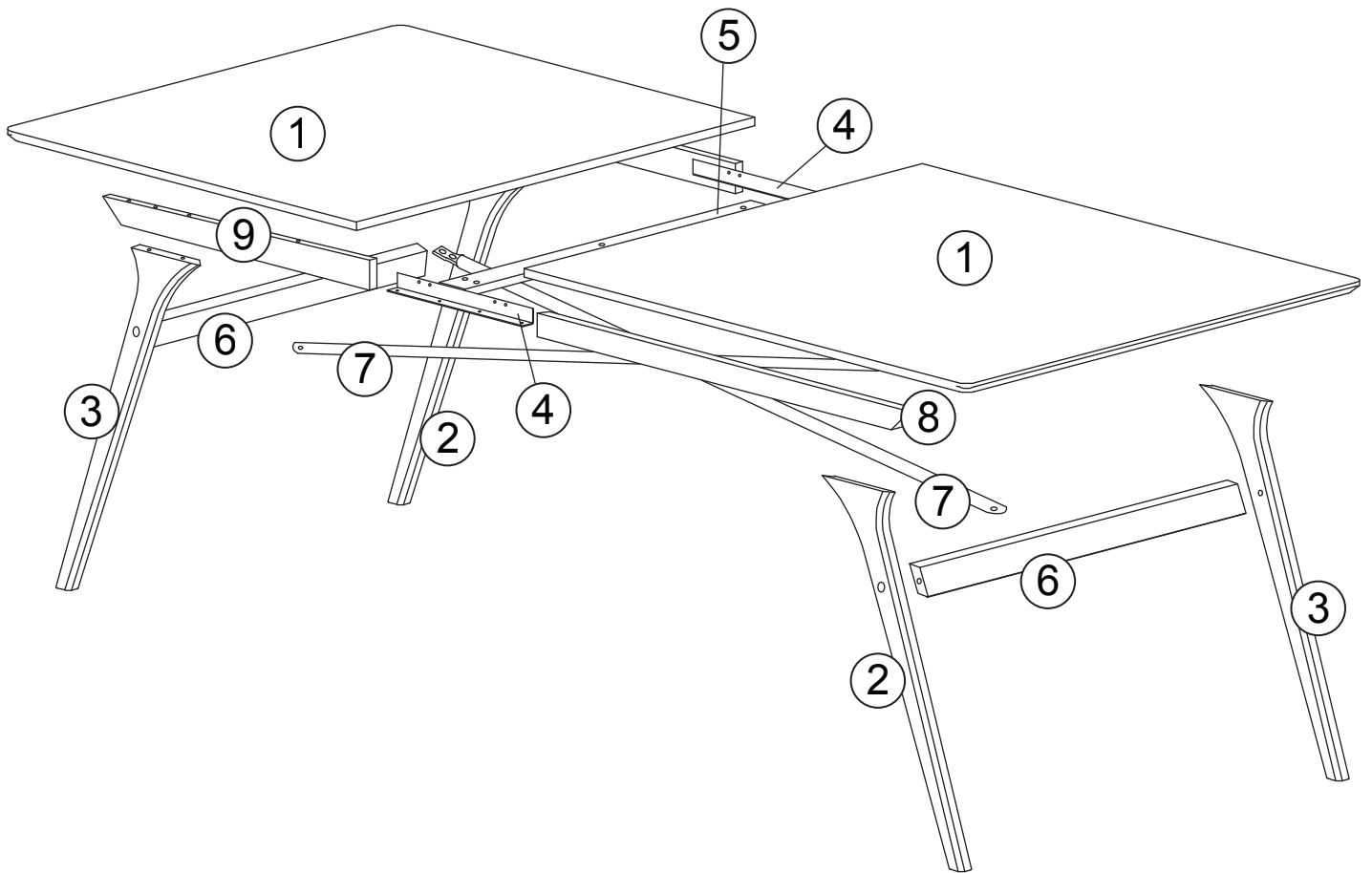

STEP 1

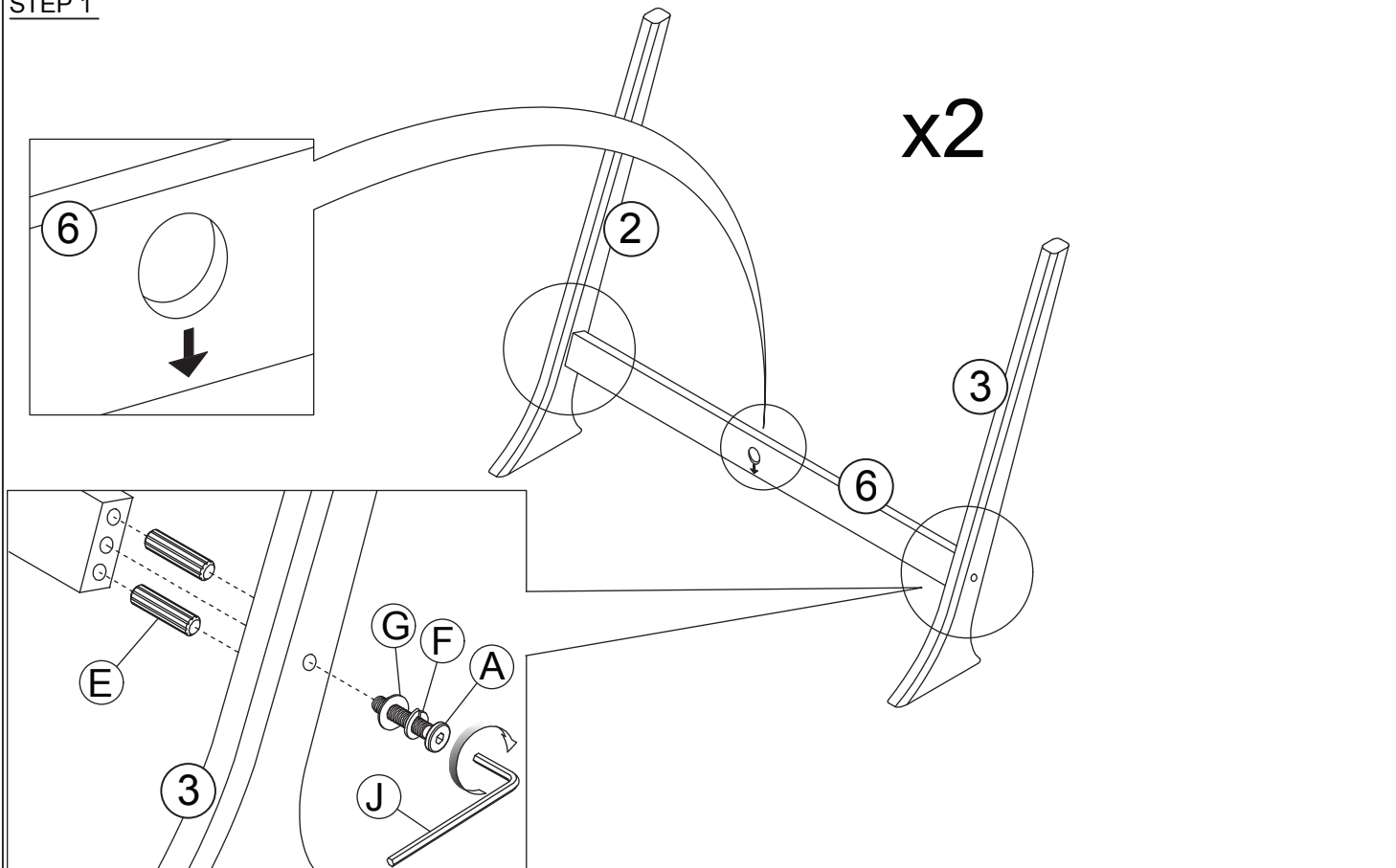

STEP 2

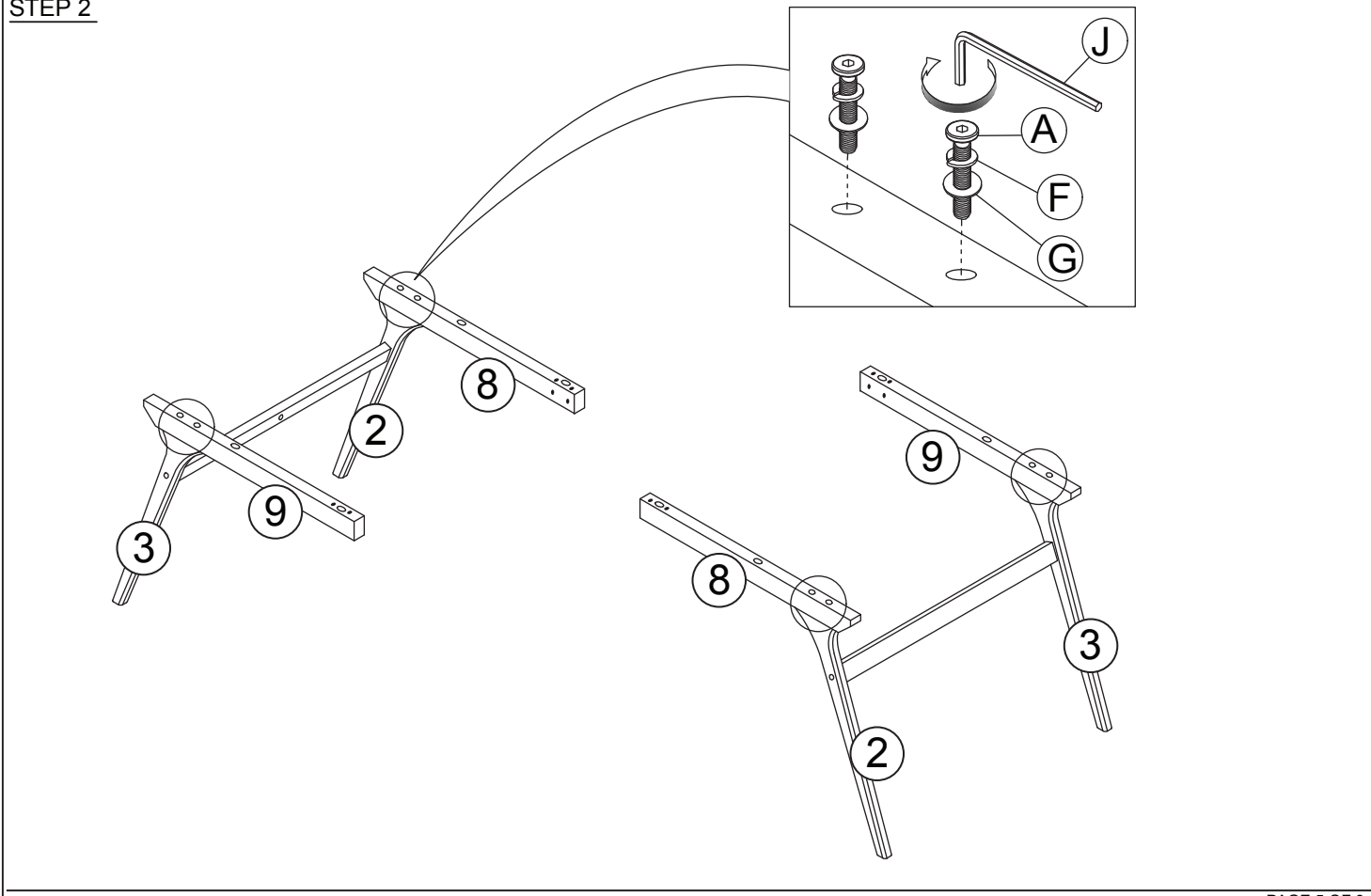

ASSEMBLY INSTRUCTION

STEP 3

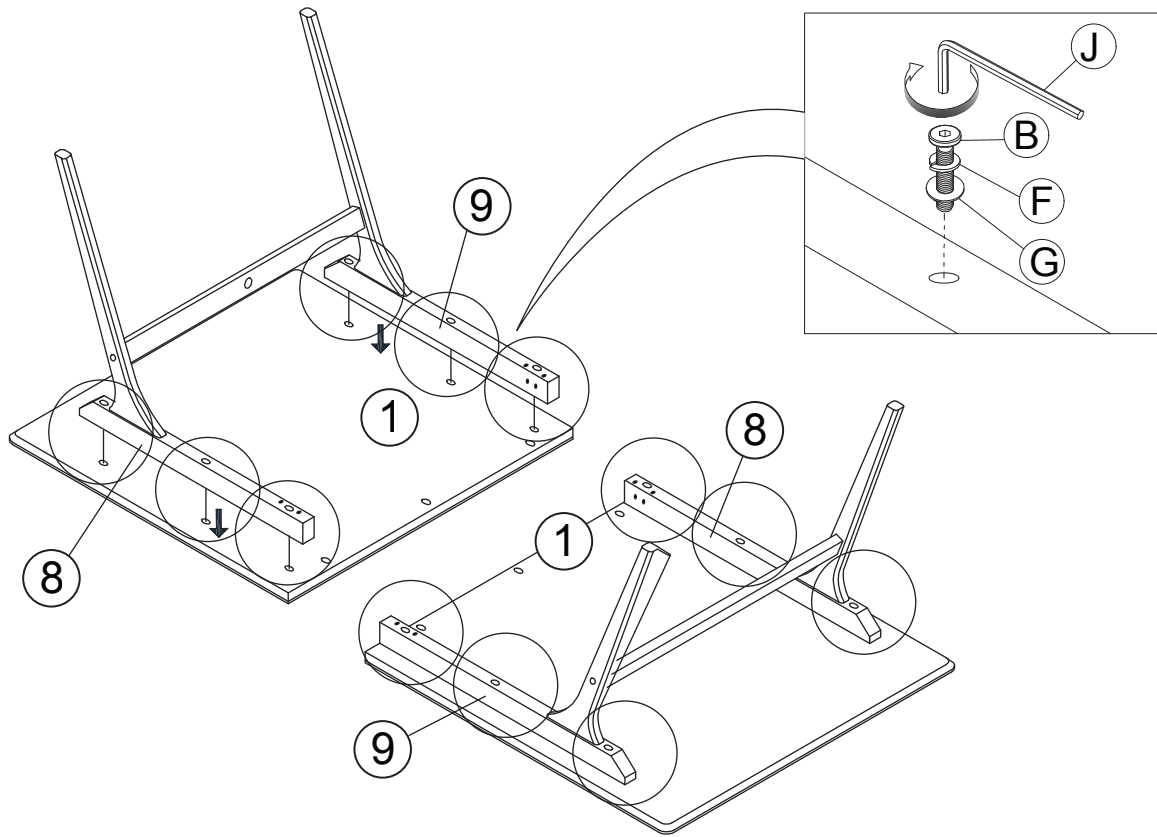

STEP 4

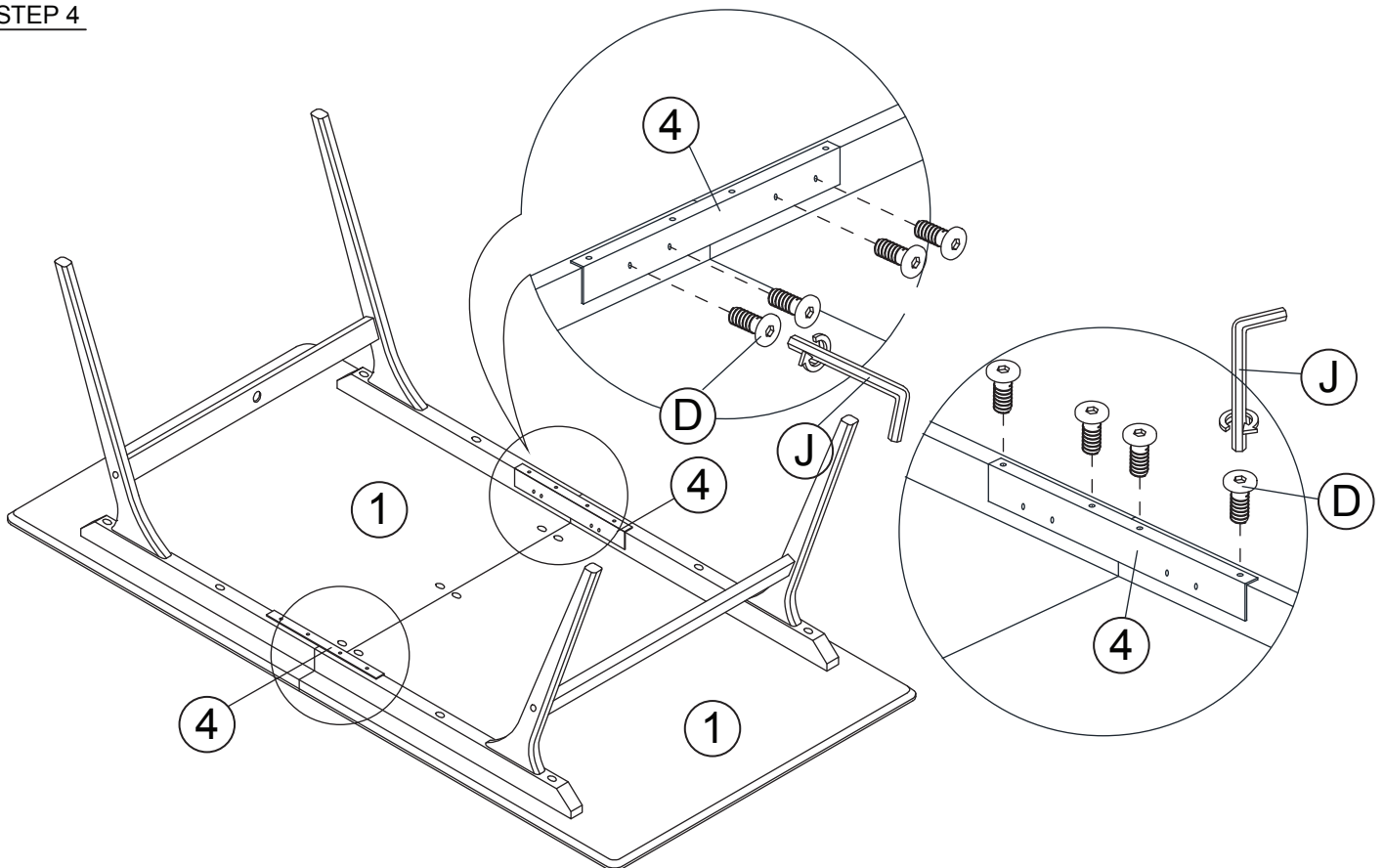

STEP 5

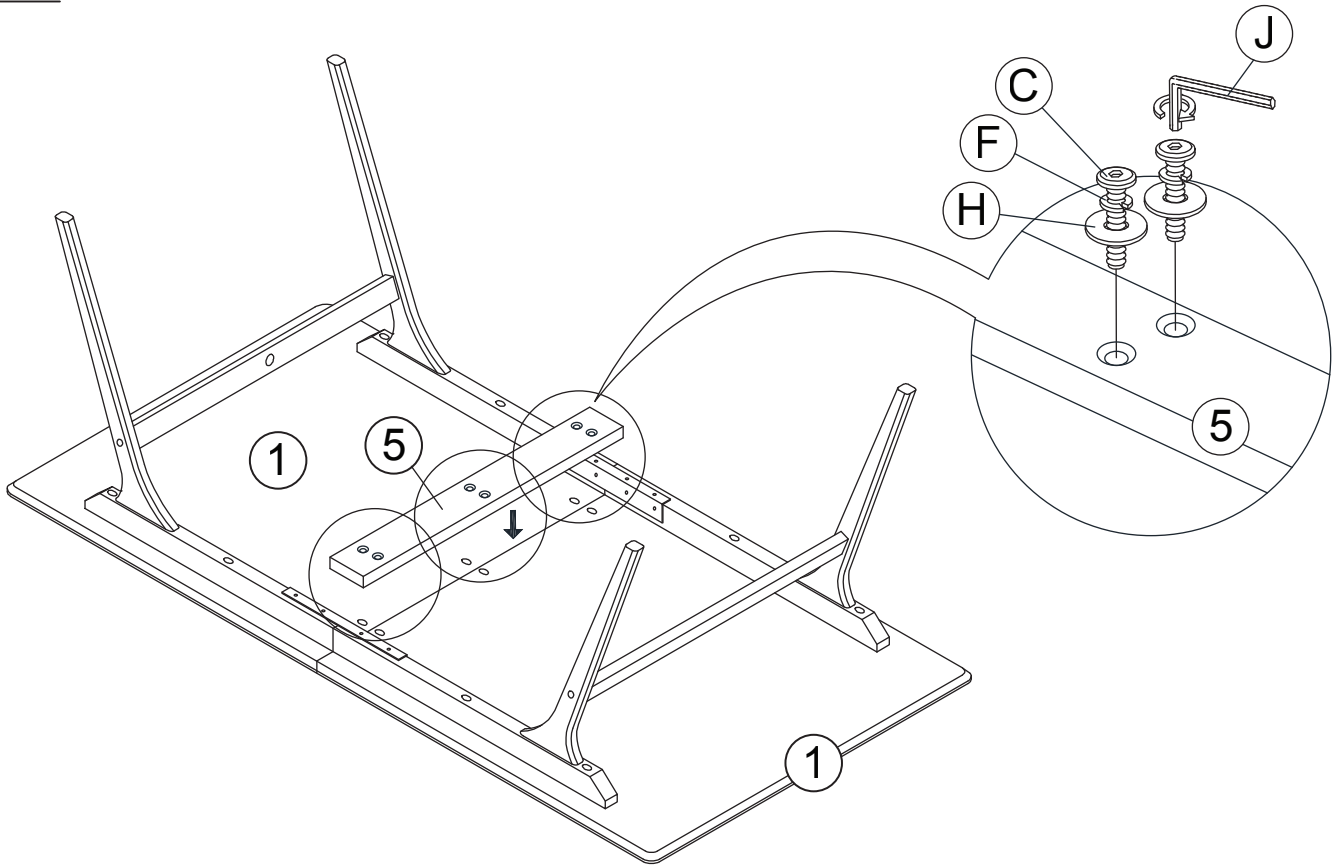

STEP 6

REMARK:
Screw must be tighten
near the midpoint.

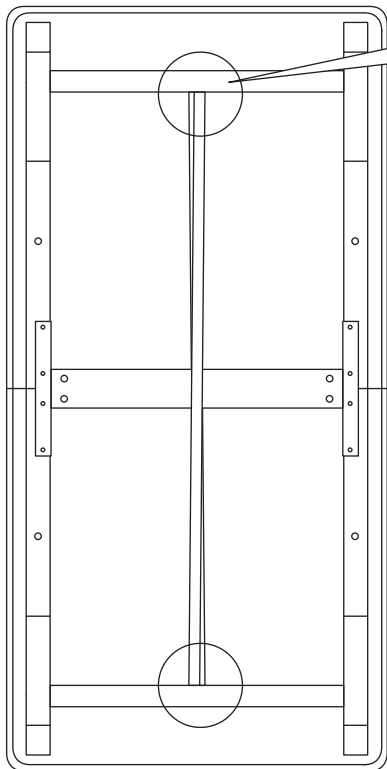

STEP 6.2

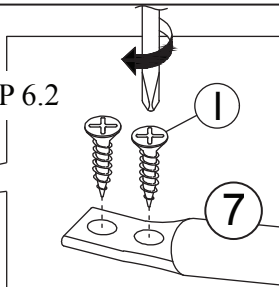

STEP 6.1

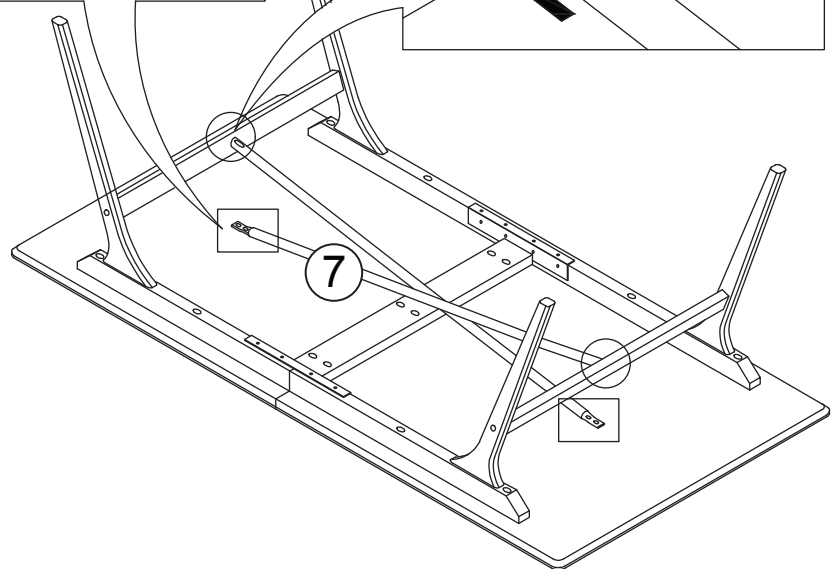
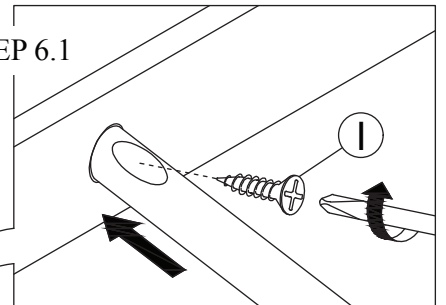

ASSEMBLY INSTRUCTION

STEP 7

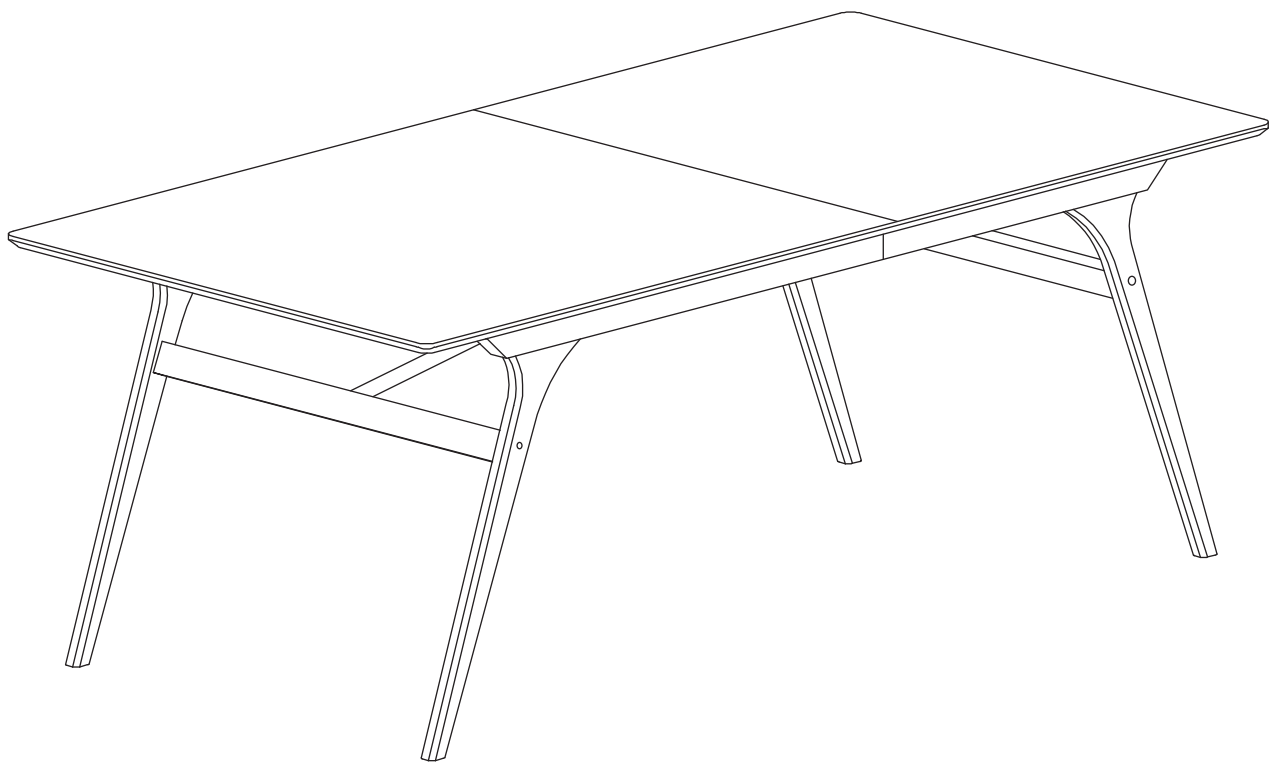

ASSEMBLY COMPLETED