

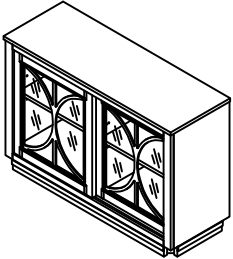







ASSEMBLY INSTRUCTIONS
ACCT CABINET

ACCT CABINET PARTS & HARDWARE LIST

 <p>(A)</p> <p>CABINETS x 1</p>	 <p>(B)</p> <p>FRONT LEGS x 2</p>	 <p>(C)</p> <p>BACK LEGS LEFT x 1</p>	 <p>(D)</p> <p>BACK LEGS RIGHT x 1</p>
<p>(H1)</p>  <p>ALLEN BOLT x 8 (Ø1/4" *50 MM)</p>	<p>(H2)</p>  <p>FLAT WASHER x 8 (Ø1/4")</p>	<p>(H3)</p>  <p>SPRING WASHER x 8 (Ø1/4")</p>	<p>(H4)</p>  <p>ALLEN KEY x 1 (M4)</p>
<p>(H4)</p>  <p>TIPPING RESTRAINT x 1</p>			

NOTES :

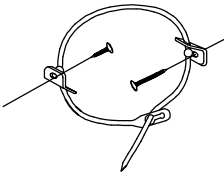
1. CHECK CAREFULLY FOR SMALL PARTS WHICH MAY COME LOOSE DURING SHIPMENT.
2. REMOVE ALL COMPONENTS FROM THE PACK AND PLACE ON A CLEAN, SOFT SURFACE TO ASSEMBLE.
3. UNITS SHOULD BE ASSEMBLED BY TWO OR MORE PEOPLE.
4. DO NOT OVER - TIGHTEN SCREW/ BOLTS UNTIL ASSEMBLY IS COMPLETED.
5. WITH USE, SCREW/ BOLT MAY BE COME LOOSE & MUST BE TIGHTENED PERIODICALLY.



ACCT CABINET PARTS & HARDWARE LIST

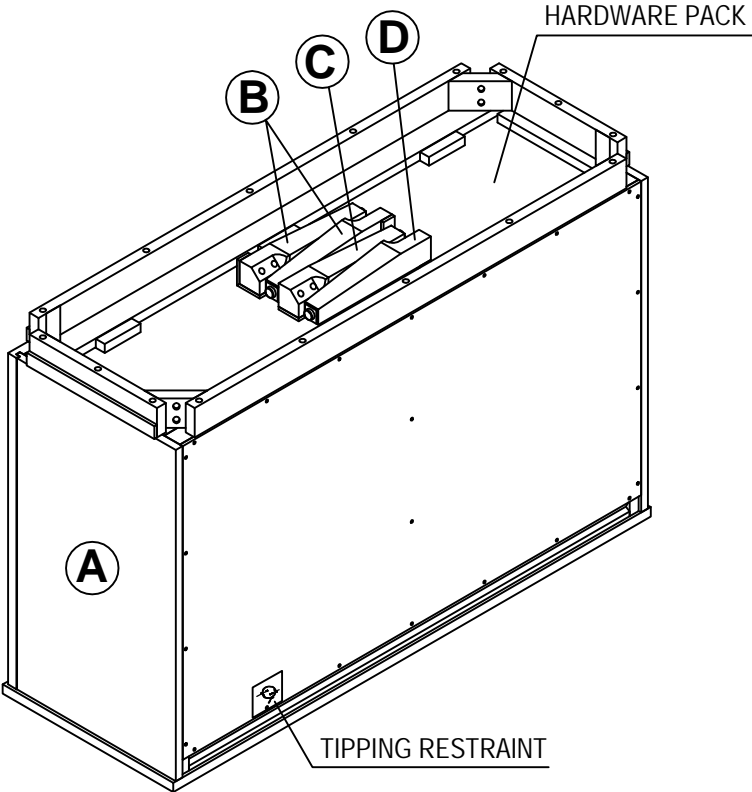

NOTES :

- 1. CHECK CAREFULLY FOR SMALL PARTS WHICH MAY COME LOOSE DURING SHIPMENT.
- 2. REMOVE ALL COMPONENTS FROM THE PACK AND PLACE ON A CLEAN, SOFT SURFACE TO ASSEMBLE.
- 3. UNITS SHOULD BE ASSEMBLED BY TWO OR MORE PEOPLE.
- 4. DO NOT OVER - TIGHTEN SCREW/ BOLTS UNTIL ASSEMBLY IS COMPLETED.
- 5. WITH USE, SCREW/ BOLT MAY BE COME LOOSE & MUST BE TIGHTENED PERIODICALLY.



ADJUSTABLE LEVELER

STEP 1

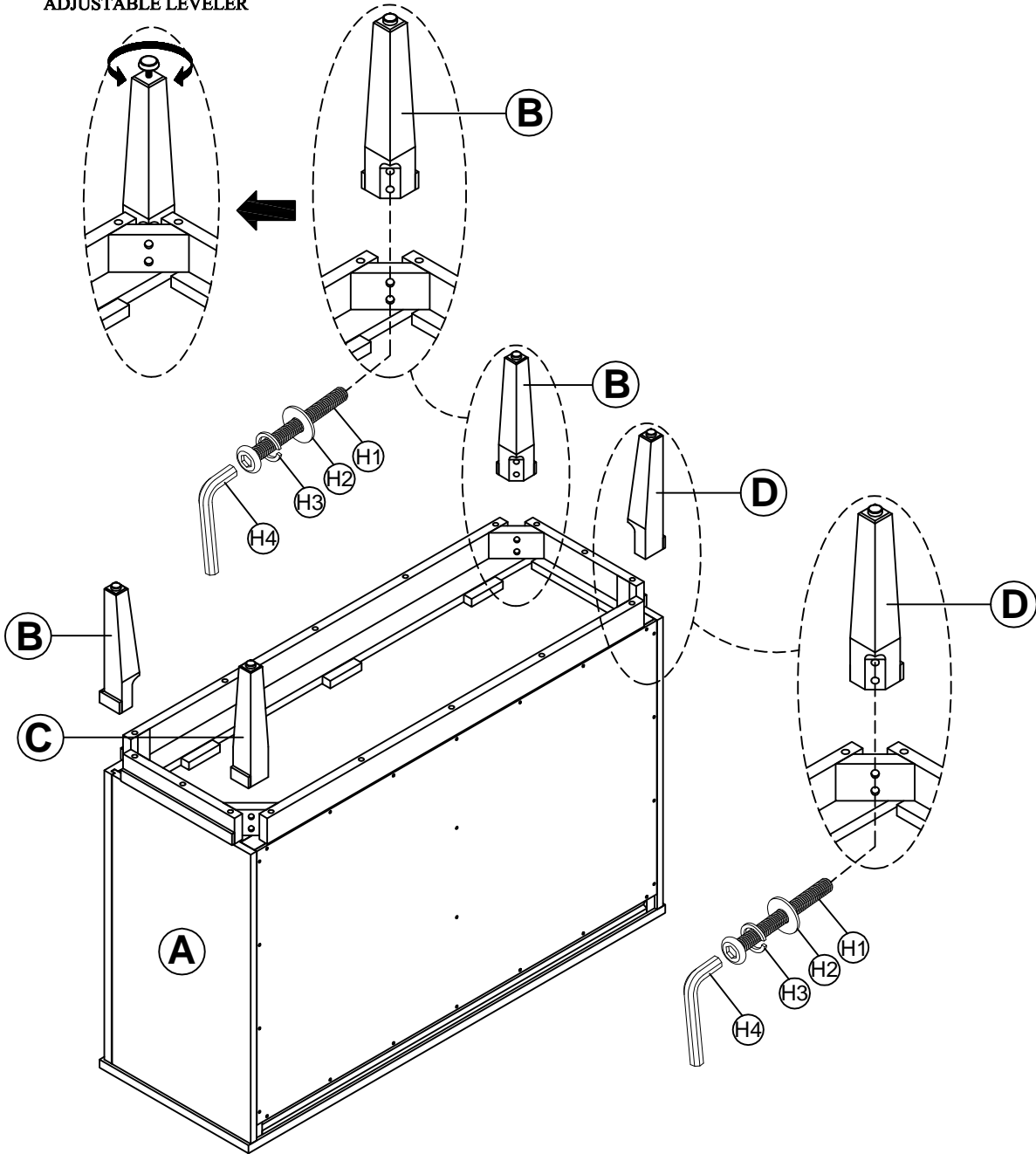

NOTES :

- 1. CHECK CAREFULLY FOR SMALL PARTS WHICH MAY COME LOOSE DURING SHIPMENT.
- 2. REMOVE ALL COMPONENTS FROM THE PACK AND PLACE ON A CLEAN, SOFT SURFACE TO ASSEMBLE.
- 3. UNITS SHOULD BE ASSEMBLED BY TWO OR MORE PEOPLE.
- 4. DO NOT OVER - TIGHTEN SCREW/ BOLTS UNTIL ASSEMBLY IS COMPLETED.
- 5. WITH USE, SCREW/ BOLT MAY BE COME LOOSE & MUST BE TIGHTENED PERIODICALLY.



ACCT CABINET

STEP 2

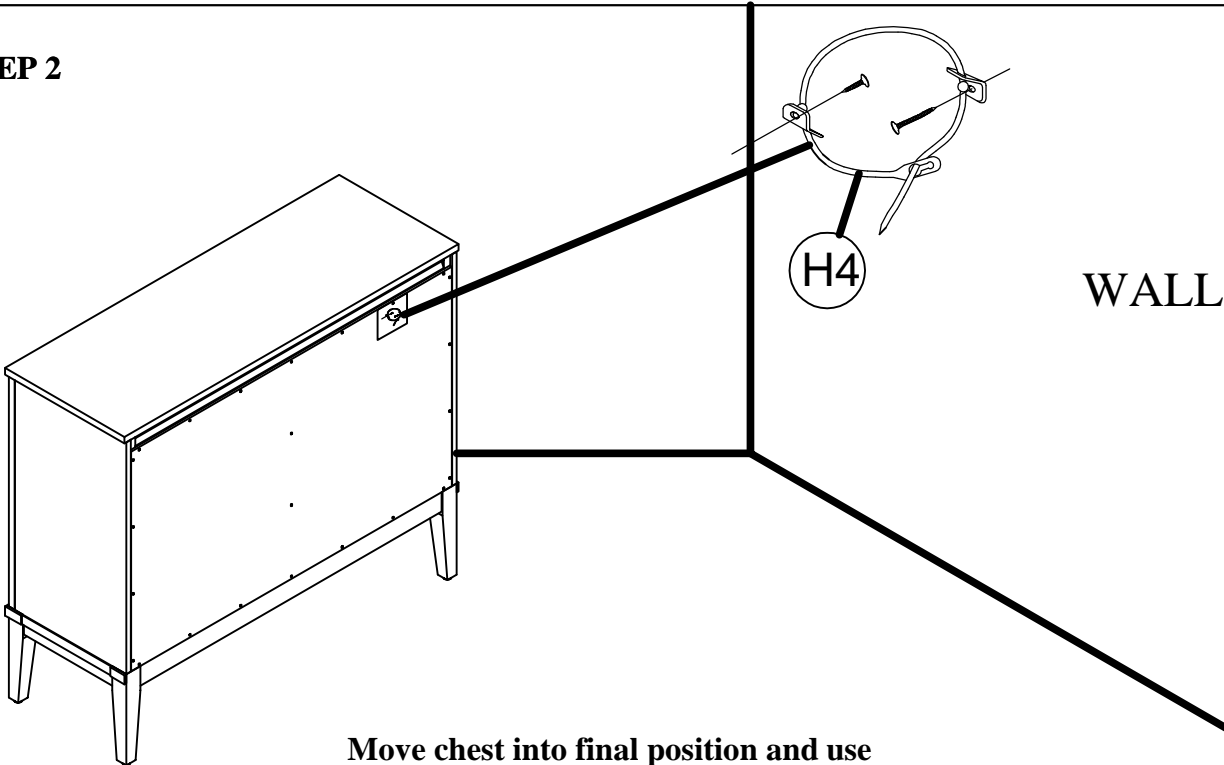

Move chest into final position and use tipping restraint to attach to the wall.

STEP 3

COMPLETED ASSEMBLY

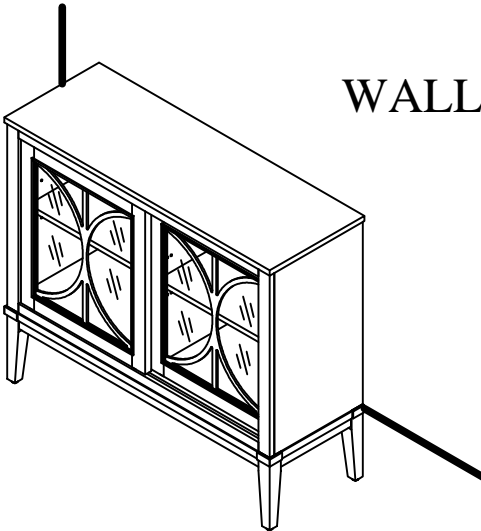

NOTES :

- 1. CHECK CAREFULLY FOR SMALL PARTS WHICH MAY COME LOOSE DURING SHIPMENT.
- 2. REMOVE ALL COMPONENTS FROM THE PACK AND PLACE ON A CLEAN, SOFT SURFACE TO ASSEMBLE.
- 3. UNITS SHOULD BE ASSEMBLED BY TWO OR MORE PEOPLE.
- 4. DO NOT OVER - TIGHTEN SCREW/ BOLTS UNTIL ASSEMBLY IS COMPLETED.
- 5. WITH USE, SCREW/ BOLT MAY BE COME LOOSE & MUST BE TIGHTENED PERIODICALLY.



STEP 4

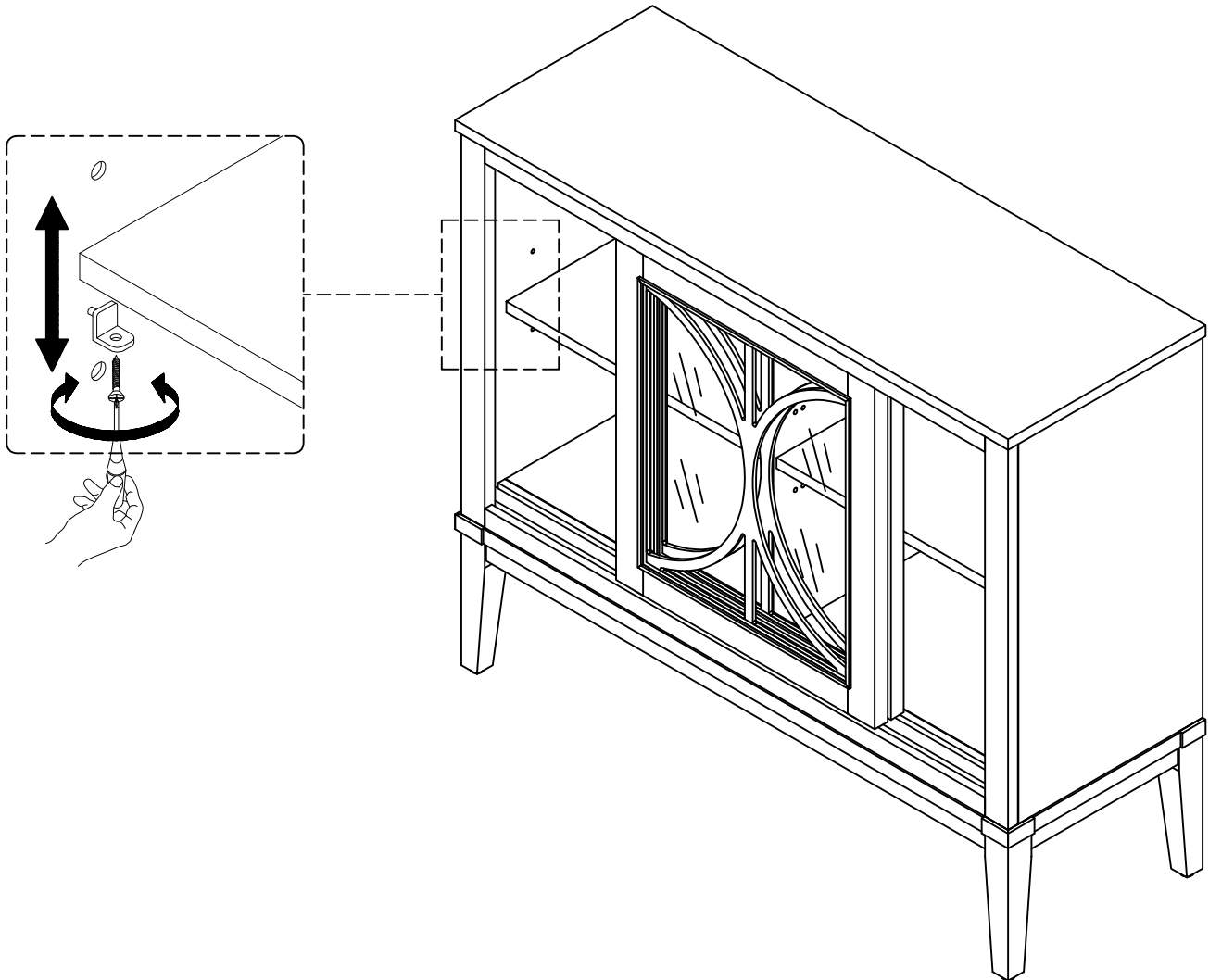

NOTES :

1. CHECK CAREFULLY FOR SMALL PARTS WHICH MAY COME LOOSE DURING SHIPMENT.
2. REMOVE ALL COMPONENTS FROM THE PACK AND PLACE ON A CLEAN, SOFT SURFACE TO ASSEMBLE.
3. UNITS SHOULD BE ASSEMBLED BY TWO OR MORE PEOPLE.
4. DO NOT OVER - TIGHTEN SCREW/ BOLTS UNTIL ASSEMBLY IS COMPLETED.
5. WITH USE, SCREW/ BOLT MAY BE COME LOOSE & MUST BE TIGHTENED PERIODICALLY.



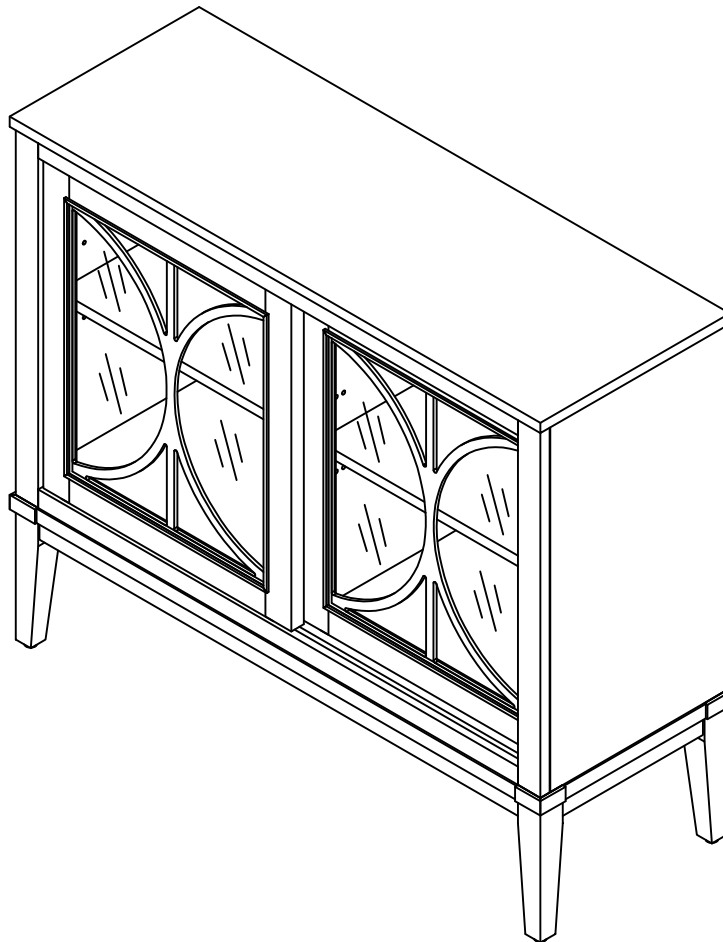

ASSEMBLY COMPLETED

NOTES :

1. CHECK CAREFULLY FOR SMALL PARTS WHICH MAY COME LOOSE DURING SHIPMENT.
2. REMOVE ALL COMPONENTS FROM THE PACK AND PLACE ON A CLEAN, SOFT SURFACE TO ASSEMBLE.
3. UNITS SHOULD BE ASSEMBLED BY TWO OR MORE PEOPLE.
4. DO NOT OVER - TIGHTEN SCREW/ BOLTS UNTIL ASSEMBLY IS COMPLETED.
5. WITH USE, SCREW/ BOLT MAY BE COME LOOSE & MUST BE TIGHTENED PERIODICALLY.

