

Assembly Instructions

Caution: You must read this before you proceed

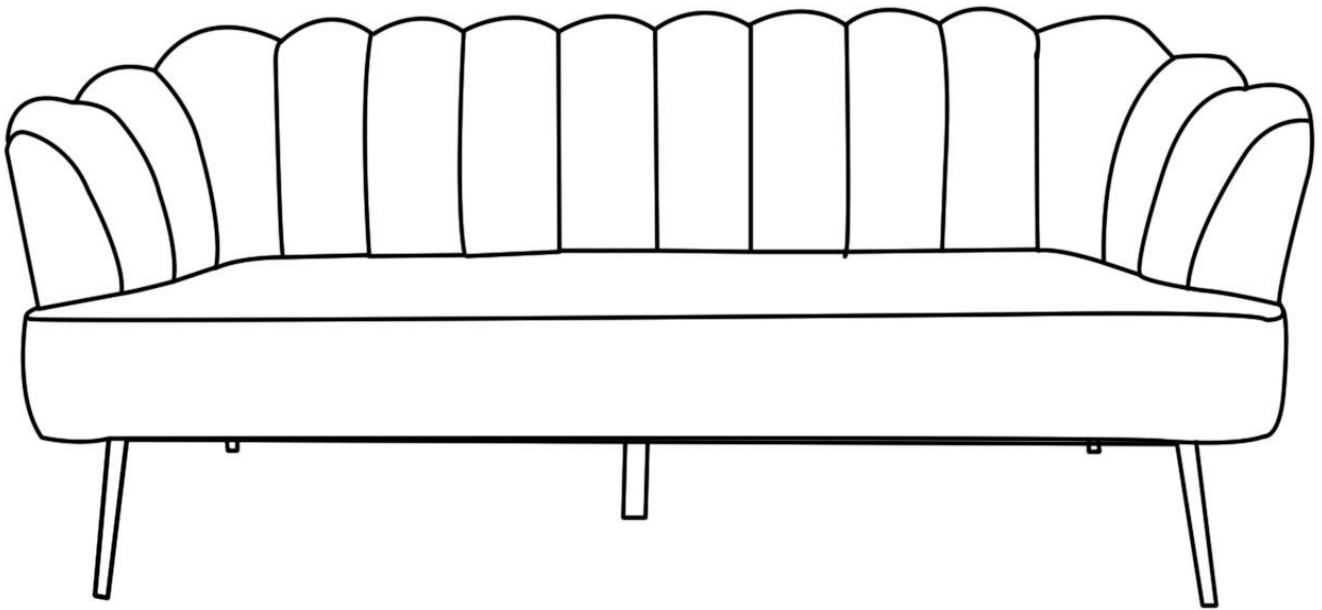

Please look in the bottom of the seat for hardware packs

3 Seater Sofa



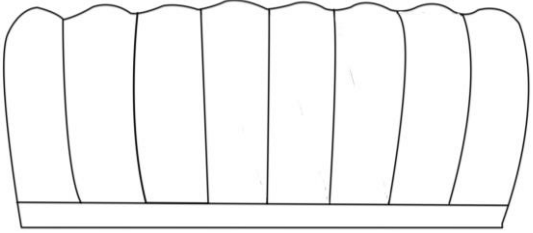
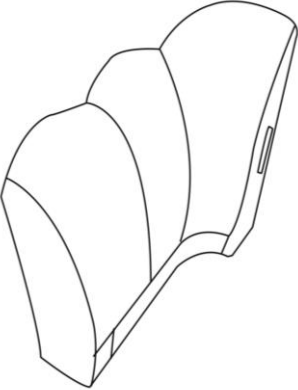
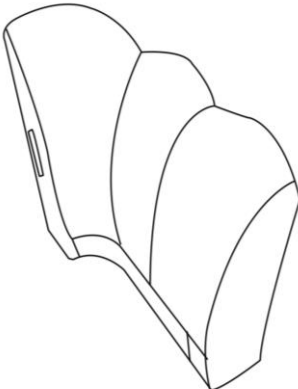
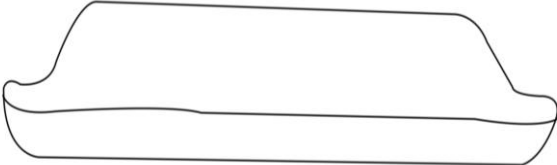







Part List

Label	Picture	Description	QTY
A		Backrest	1
B		Left Armrest	1
C		Right Armrest	1
D		Seat	1

E		Leg	4
F		Middle Support Leg	1

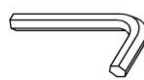
Hardware

Label	Picture	Description	QTY
①		Bolt (M8*65MM)	6
②		Washer (M8*22*2MM)	6
③		Spring Washer (M8*12*2MM)	6
④		Bolt (M6*20MM)	17
⑤		Washer (M6*16*1MM)	17
⑥		Spring Washer (M6*9*1.5MM)	17
⑦		Allen Wrench(M8)	1
⑧		Allen Wrench(M6)	1
⑨		Gasket	2

Assembly Preparation

Before
Beginning
Assembly:

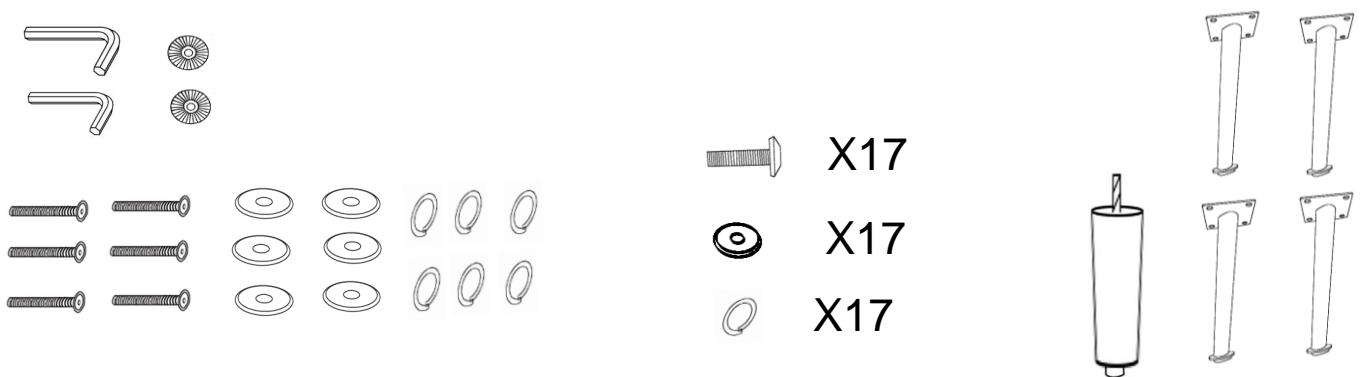
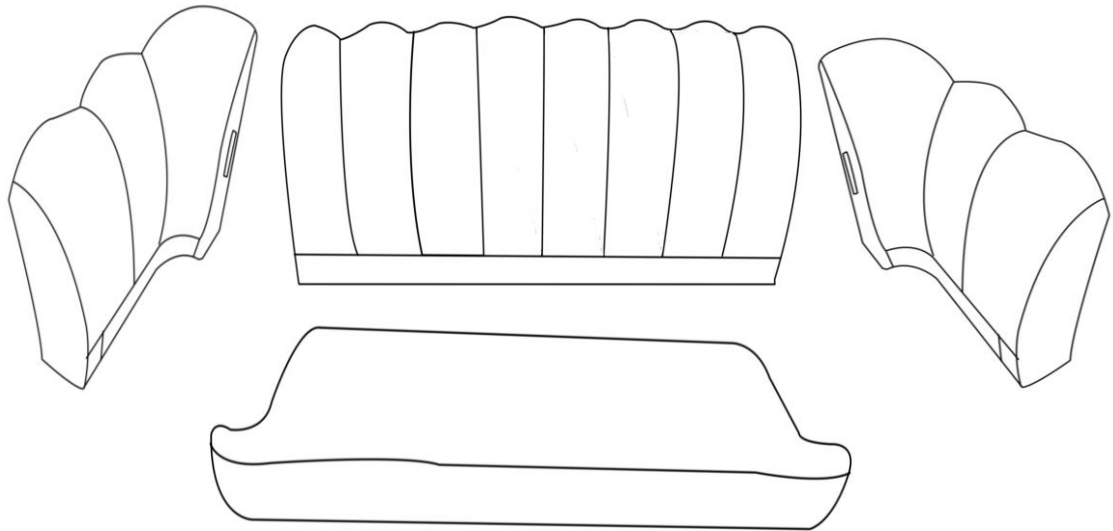

- Read instructions, cover to cover-



- Have 2 adults on hand for assembly-



- Do not assemble on flooring or carpet-



- Assemble on a clean non-marring surface (packing foam)-



- Save all packaging until finished-

Assembly Steps

Overview

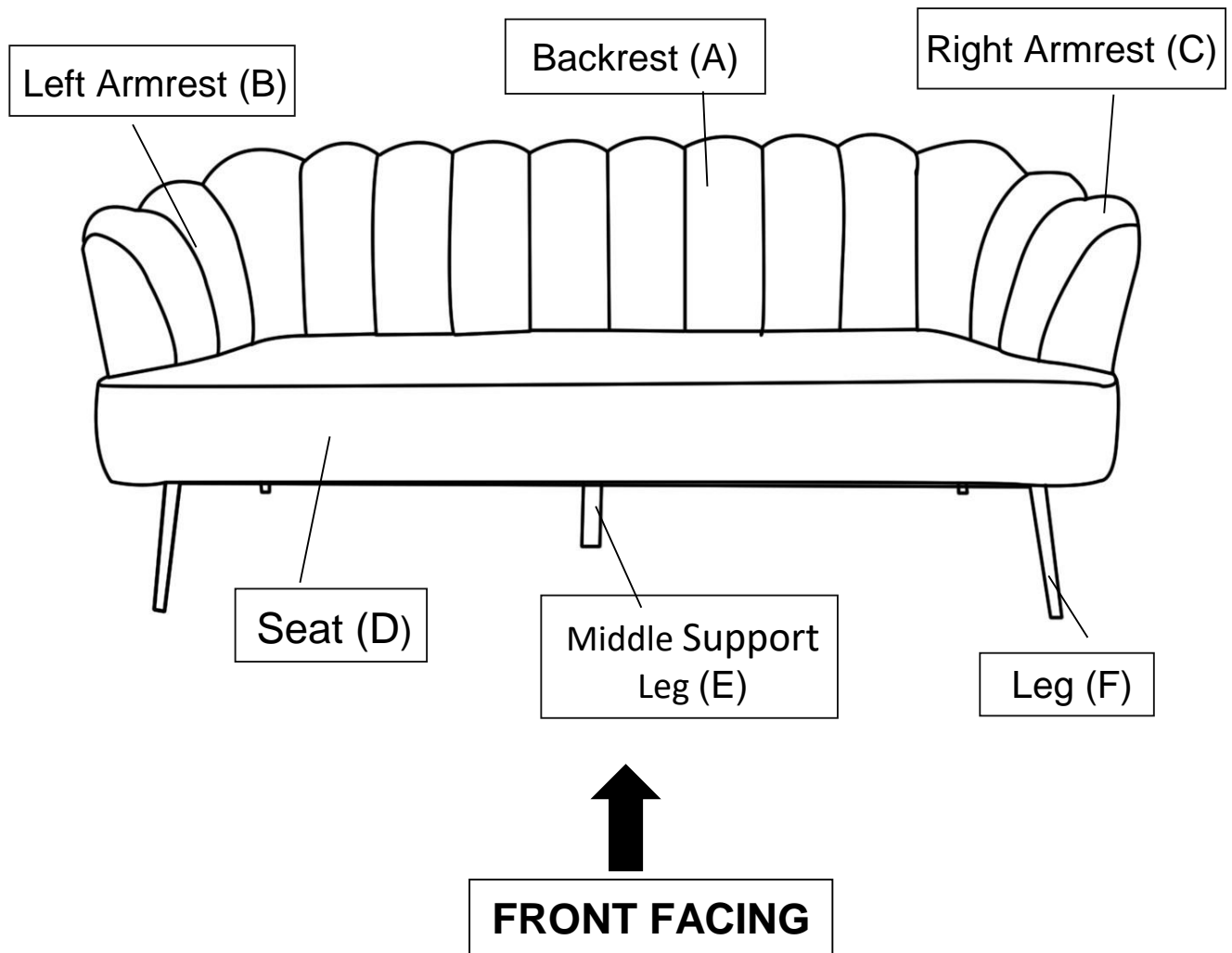

This Sofa has multiple parts and may require up to 60 minutes to assemble. To give you an overview of the Sofa parts, the above picture is to help you put the various parts into perspective. Please read through the instructions below to familiarise yourself with the parts and steps before assembly.

Note: It is recommended that you have an adult partner to assist during the entire assembly process.

Step 1

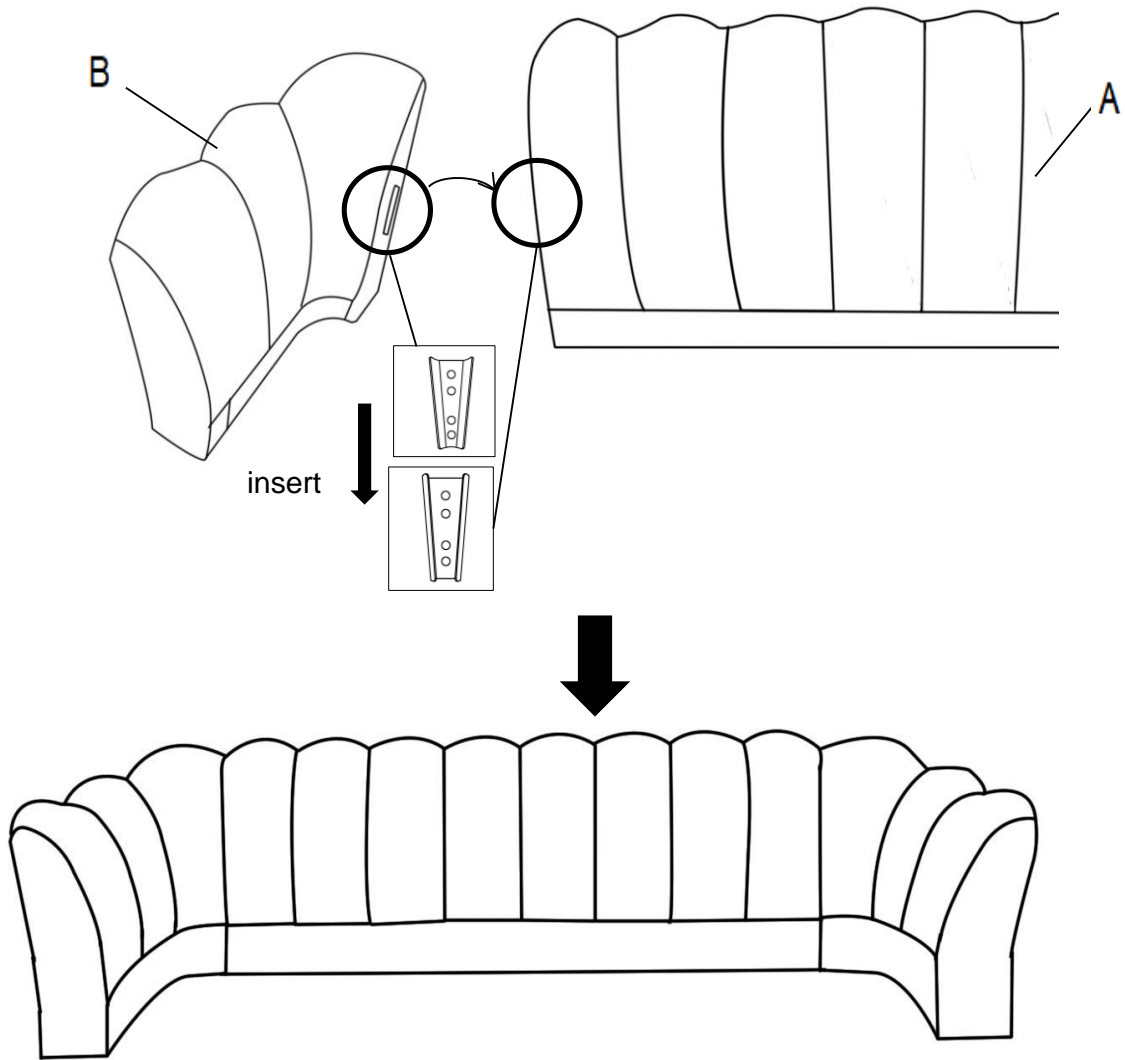

Open the carton and place all the parts on a clean, non-marring surface.

With the assistance of your adult partner, align the mounting brackets on the Left Armrest(B) with those on the left of Backrest(A). Then slide the Left Armrest(B) downwards to make sure it locks into place as pictured.

Repeat the same process to attach the Right Armrest(C) into the Backrest(A).

Note: Make sure the mounting brackets on the Left Armrest(B) and the Right Armrest(C) lock into the mounting brackets on the Backrest(A).

During this assembly process you may need to use your hand to press down and or pave away the padded surface to facilitate the 'slip and slide' assembly.

Caution: Ensure that your fingers do not get caught or pinched in the assembly process. Push the Armrest downwards until it is fully slotted and locked into position onto the Backrest.

Fully locked position: Check and assess that the base of the Armrests(B&C) and Backrest(A) are aligned and level.

Step 2

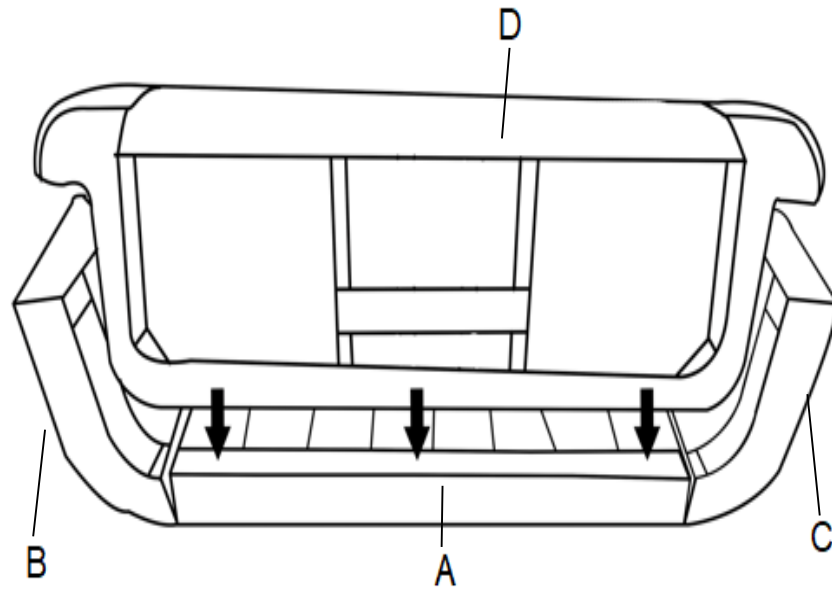

With the assistance from your adult partner, lay the assembled Backrest down on a flat surface. Attach the Seat (D) to the assembled Backrest (A) by aligning the mounting position on the Seat (D) with those on the Left Armrest (B), the Right Armrest (C) and the Backrest (A).

Step 3

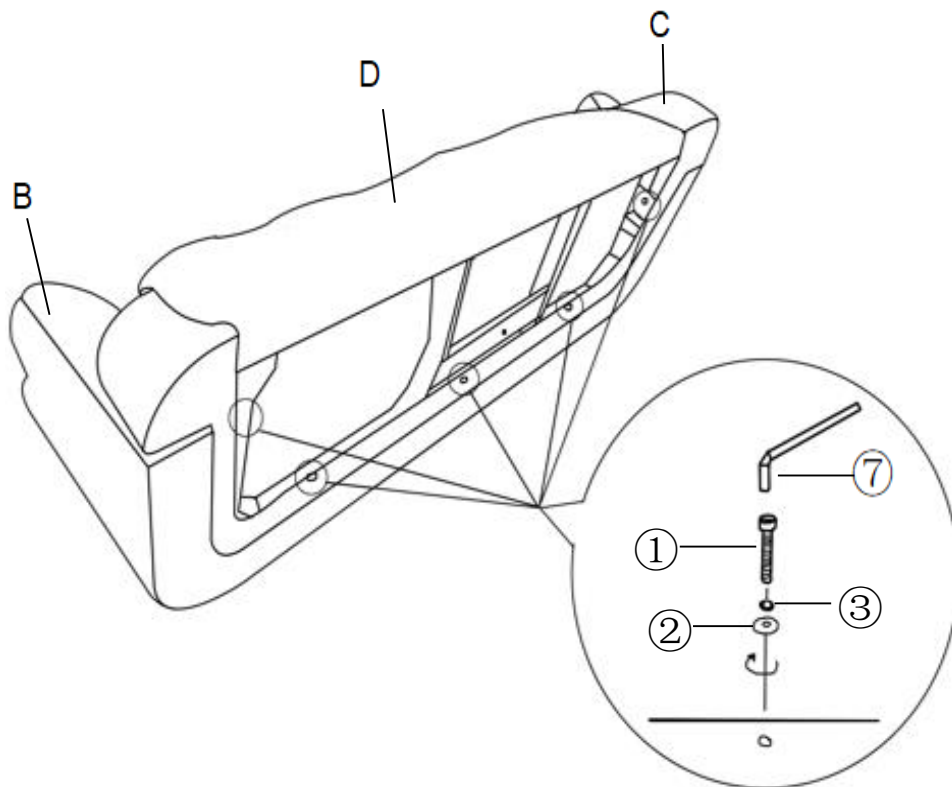

Tighten the Seat (D) to the assembled Backrest using Bolts (①), Spring Washers (③), and Washers (②) with the Allen Wrench (⑦) as pictured above.

Tighten the Bolts fully in a sequential manner.

DO NOT fully tighten a Bolt in one go and then move on to the next.

Rather, In a sequential manner, gradually tighten each Bolt until all Bolts are evenly secured.

This methodology will ensure maximum evenness once all Bolts are fully tightened.

Note: If you can not insert the Bolts into position, please go back to Step 2.

Step 4

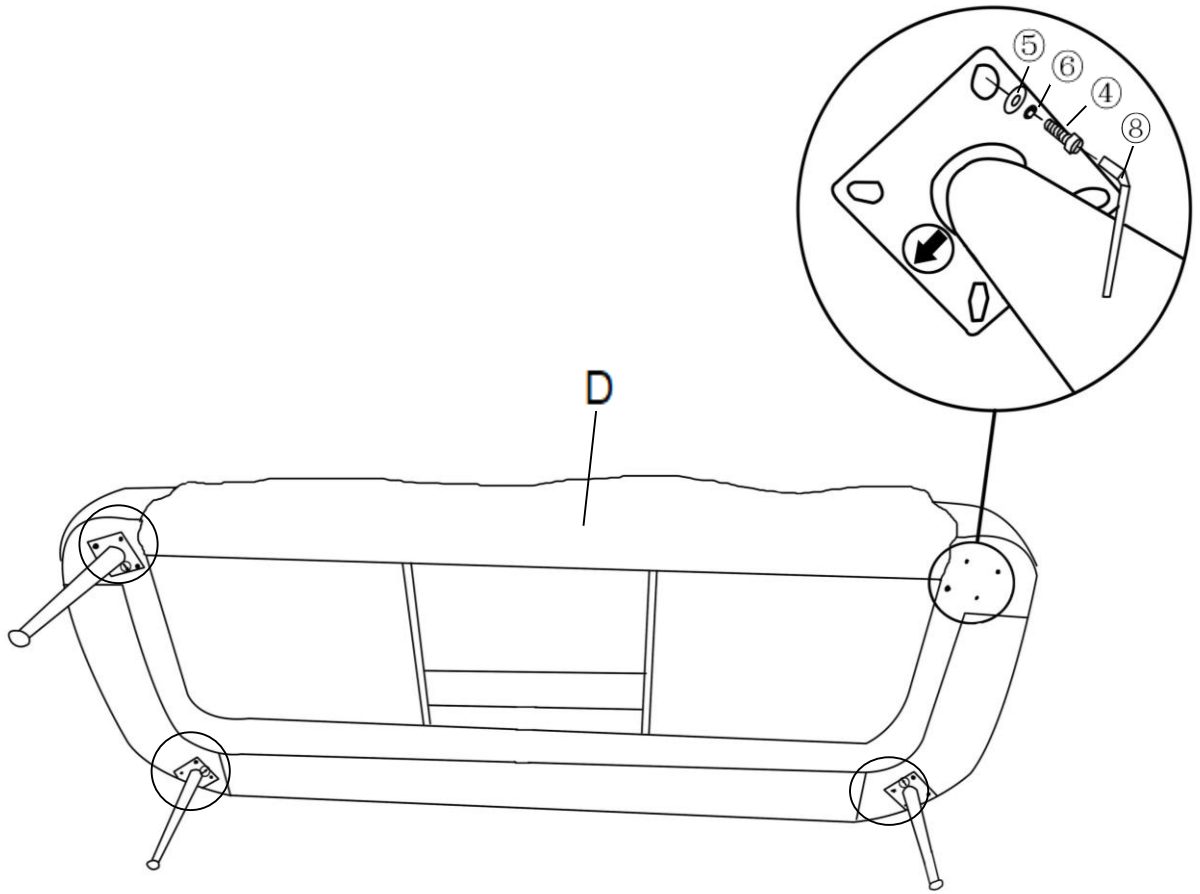

Attach the Legs(E) to the Seat(D) using Bolts(④), Spring Washers(⑥), and Washers(⑤) with the Allen Wrench(⑧).

Note :Please pay attention that all legs(E) should be installed in an outward facing position.

Step 5

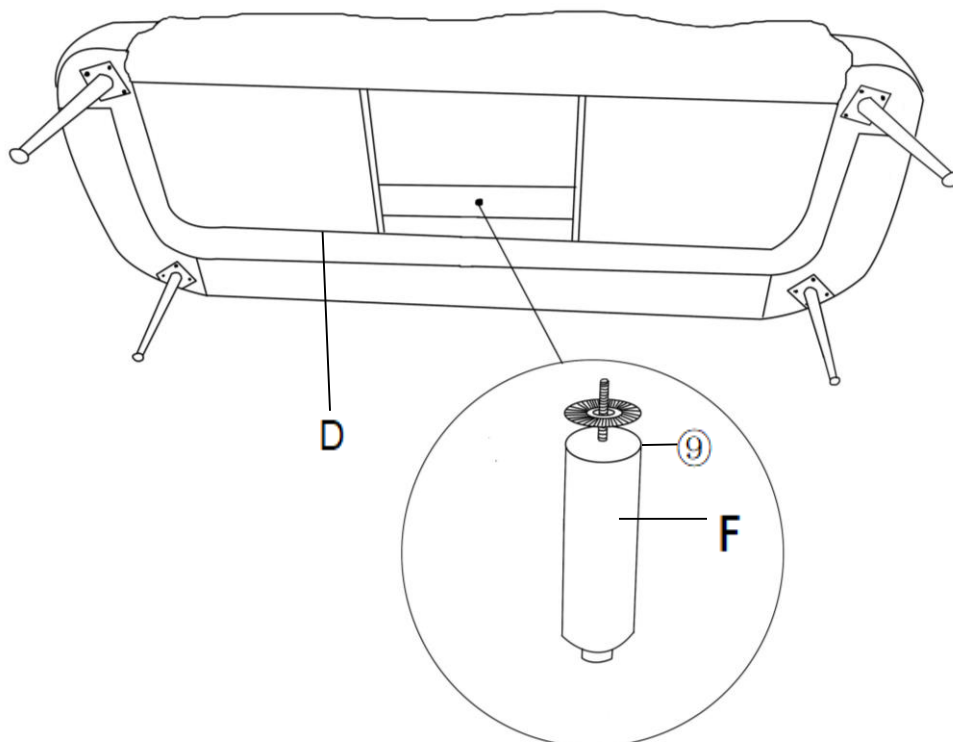

Attach the Middle Support Leg(F) onto the middle of the Sofa(D) bottom using one Gasket(Ⓞ).

Tighten by turning the Leg clockwise.

Note:If the Middle Support Leg(F) is too short, you can add an extra Gasket.

Step 6

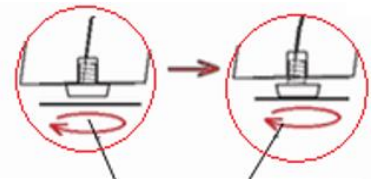
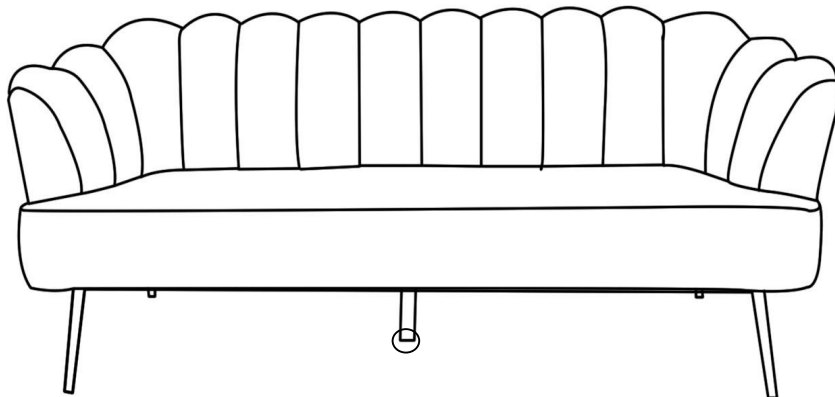

Adjust Pre-installed Levellers height to achieve balance

With the assistance from your adult partner,turn the Sofa up.

If the Sofa wobbles, adjust the Pre-installed Levellers on the Middle Support Leg(F) until the Sofa is level.

Your Sofa is ready for use.

This Sofa can only be used on a flat, level surface.

Care & Maintenance



- Furniture may scratch floors. We recommend using furniture pads to protect your floors.



- Do not put hot items directly on furniture surface.



- Do not clean furniture with harsh cleansers or polish.



- Do not place furniture under direct sunlight.



- Do not place furniture near heating or cooling vents.



- Do not write on furniture without a padded barrier to protect the surface.



- Do not place furniture outside . For indoor use only.



- Not for commercial use. For residential use only.



- Stains may be removed with mild soap solution and damp cloth.



- Children should not climb or jump on the furniture.



- Dust and pick-up spills using a clean, non-colored, lint-free cloth.