

ASSEMBLY INSTRUCTIONS

MODEL #

CM4401E

Questions?

GIVE US A CALL: 1-888-980-5122
MON – FRI 8:30AM – 5:30PM (PST)

TOOLS REQUIRED



Allen Wrench

(Included)

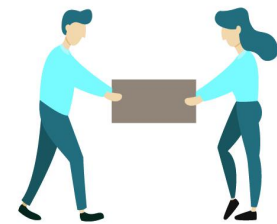
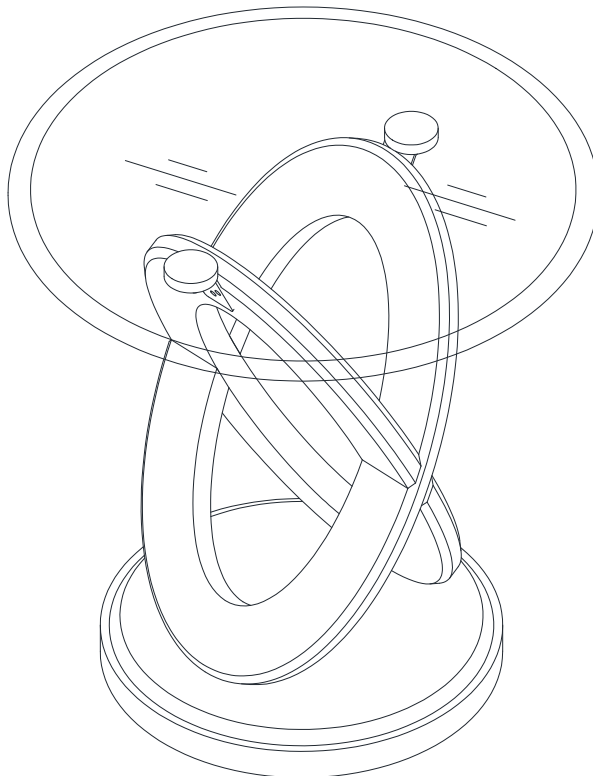

**2 - Persons
Recommended**

ASSEMBLY RATING



EASY —————> DIFFICULT

The Assembly Rating is a 5-point system showing the level of effort needed to assemble a specific product.



Thank you for your purchase!

We hope you enjoy this new addition to your home for many years to come.

Our commitment to providing quality products does not simply end when you purchase our product. We fully stand behind our products from start to finish. Our customer service department is available Monday – Friday 8:30 AM – 5:30 PM Pacific and can help with assembly questions as well as, if necessary, replacing damaged or missing parts. To help expedite our service, please have these assembly instructions readily available, along with your order receipt.



Consumer Hotline
Toll-Free 1-888-980-5122



Monday to Friday
8:30AM- 5:30PM (PST)



WEBSITE
www.foagroup.com



E-MAIL
cs.ec@foagroup.com



foagroup



FurnitureOfAmerica



CHECK BEFORE STARTING



Are you missing anything?

Double-check all parts, hardware and accessories listed on Page 6 are accounted for.



Check out our Quick Tips!

We recommend reviewing the pre-assembly handouts. Even experts need a refresher now and then!



Should we send any replacements?

Are there any irregularities or flaws in the parts? We can send replacements!



Prep Time!

Please review the assembly instructions and all diagrams prior to assembling. Set up your workspace by laying the parts and hardware out separately, then begin!

PRE ASSEMBLY INTRODUCTION

We understand building ready-to-assemble furniture can be a challenging experience for some. To help avoid confusion, we have provided some helpful tips that may speed up the process.

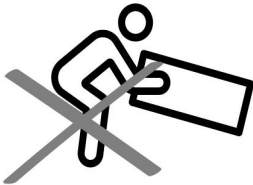

Teamwork

ALWAYS have at least two people to help with transporting and assembling the product to avoid potential injury and/or damage.

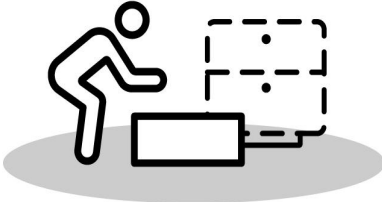
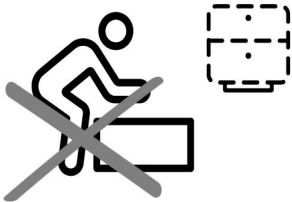

Suitable Location

Assembling near the area of the intended location is highly recommended.



Sufficient Space

Make sure you have enough space to move around during the assembly.



Avoid Scratches

Use cardboard, blankets or a carpeted area while assembling furniture to prevent scratches.

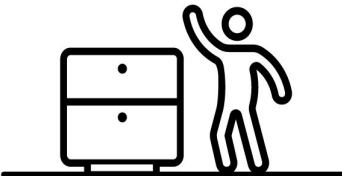
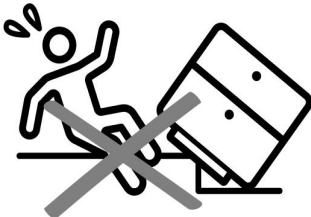

Flat Surface

Make sure the furniture rests on a flat and level surface with each leg evenly touching the floor.

ASSEMBLY AND CARE ADVICE



FAILURE TO FOLLOW THE GUIDELINES BELOW MAY RESULT IN INJURY AND/OR PROPERTY DAMAGE.



Position each part correctly and insert screws or bolts into their respective holes.

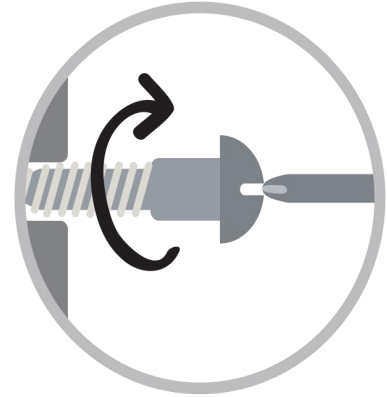

Turn clockwise to tighten and only tighten when step is completed or when instructed to do so.



Use the appropriate hand tools or power tools for assembly. Select steps, such as tightening screws and/or bolts, may require hand tools to avoid causing damage during assembly.



Save the instructions and store any supplied tools for later maintenance.

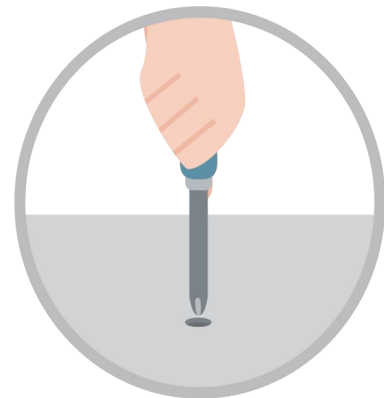

After two weeks, check and tighten any loose hardware and repeat again every six months thereafter.

IT IS THE USER'S RESPONSIBILITY TO MAINTAIN THE FURNITURE. THE HARDWARE MAY LOOSEN OVER TIME AND MAY CAUSE THE FURNITURE TO BE WOBBLY AND UNABLE TO SUPPORT ITS INTENDED WEIGHT CAPACITY. THIS MAY LEAD TO COLLAPSE AND MAY CAUSE SERIOUS INJURY.

END TABLE

CM4401E



- Please keep instructions for future reference.
- Check the quantity and irregularity of parts and hardware before you start.

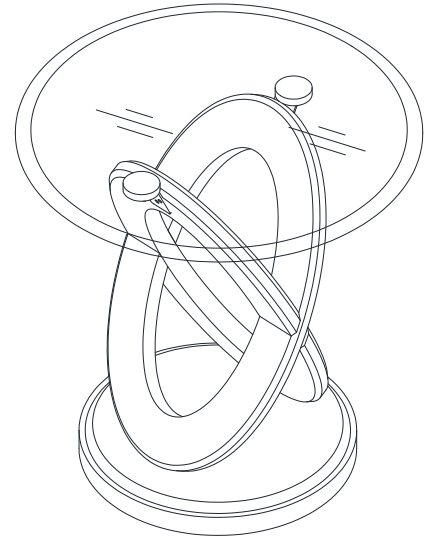

PARTS

#1 1pc

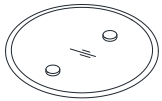

Glass Top

#2 1pc



Leg (A)

#3 1pc



Leg (B)

#4 1pc

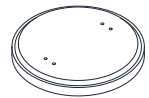

Bottom

HARDWARE

#A 6pcs

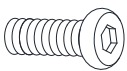

Bolt \varnothing 5/16" x 1/2"

#B 8pcs

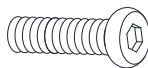

Bolt \varnothing 5/16" x 3/4"

#C 4pcs

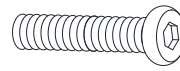

Bolt \varnothing 5/16" x 1-1/4"

#D 18pcs



Lock Washer \varnothing 5/16"

#E 18pcs



Flat Washer \varnothing 5/16"

#F 1pc



Allen Wrench

#G 2pcs



Metal Plate

#H 1pc



Bracket

ASSEMBLY INSTRUCTIONS

1

Remove the bolts on the bracket (#H) that is attached to leg B (#3) by using an Allen wrench (#F), then remove the bracket (#H) from leg B (#3).

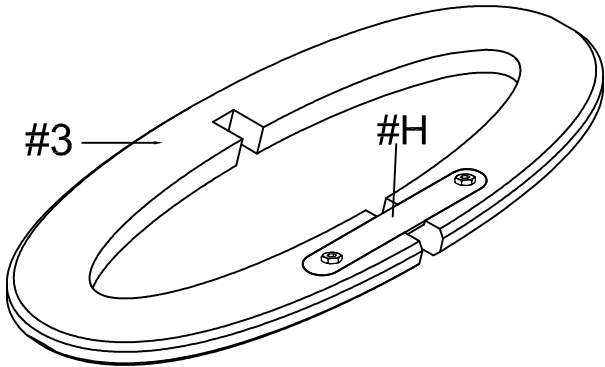
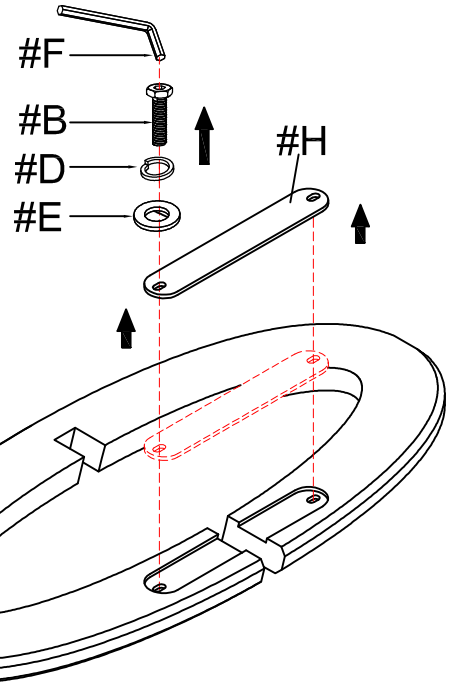

#3

- 2
- Part #2 x1pc
 - Part #3 x1pc
 - Hardware #B x 8pcs
 - Hardware #D x 8pcs
 - Hardware #E x 8pcs
 - Hardware #G x 2pcs
 - Hardware #H x 1pc

1) Prepare 8 bolts assembly by inserting lock washer (#D), then flat washer (#E) onto bolts (#B).

3) Insert bracket (#H) through leg A (#2), then secure bracket (#H) with bolts (#B).

2) Attach leg A (#2) to leg B (#3).

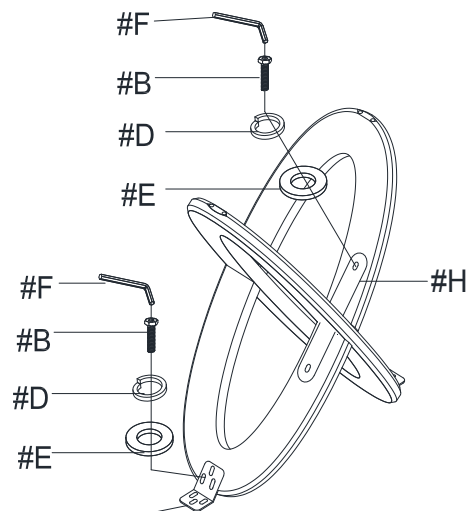
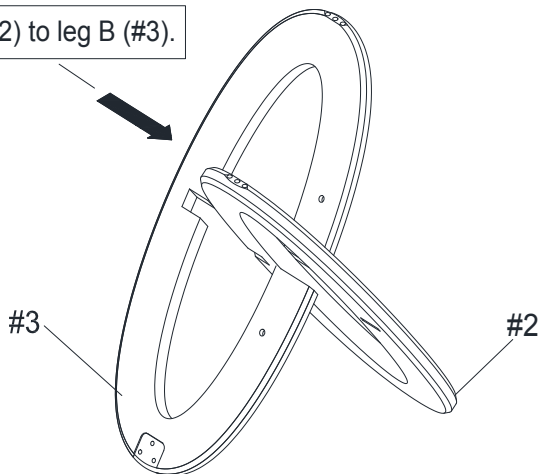

4) Align metal plate (#G) to the holes of leg (#2,3), then secure with bolts (#B).

#G

ASSEMBLY INSTRUCTIONS

3

- Part #4 x1pc
- Hardware #C x4pcs
- Hardware #D x4pcs
- Hardware #E x4pcs

Prepare 4 bolts assembly by inserting lock washer (#D), then flat washer (#E) onto bolts (#C).

Align bottom (#4) to the holes of the legs (#2,3), then secure with bolts (#C).

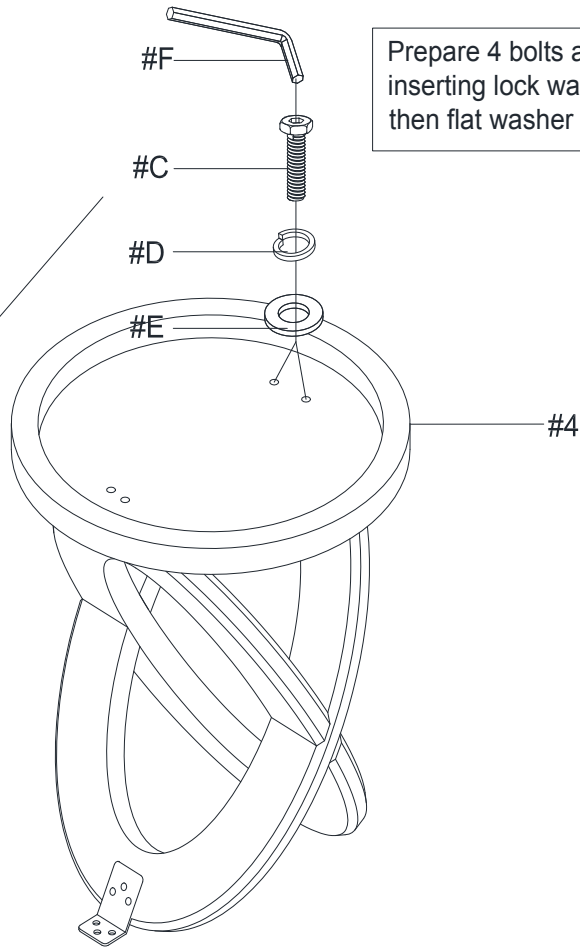

4

- Part #1 x1pc
- Hardware #A x6pcs
- Hardware #D x6pcs
- Hardware #E x6pcs

Prepare 6 bolts assembly by inserting lock washer (#D), then flat washer (#E) onto bolts (#A).

Align the metal plate on the base to the holes of the glass top (#1). Secure with bolts (#A).

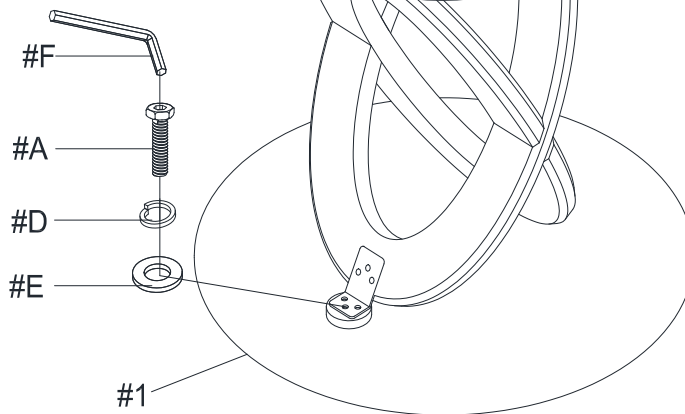

ASSEMBLY COMPLETED

Please ensure the furniture rests on an even and flat surface. If the product wobbles or feels loose, double-check all bolts and/or screws are properly tightened and secured.



Keep this handy!

Please retain this instruction manual and any order-related information for future reference.