

ASSEMBLY INSTRUCTIONS



WRITING DESK

ASSEMBLY INSTRUCTIONS

ASSEMBLY TIPS:

1. Remove hardware from box and sort by size.
2. Please check to see that all hardware and parts are present prior to start of assembly.
3. Please follow attached instructions in the same sequence as numbered to assure fast & easy assembly.



WARNING!

1. Don't attempt to repair or modify parts that are broken or defective. Please contact the store immediately.
2. This product is for home use only and not intended for commercial establishments.





ASSEMBLY TIME

40 MINUTES

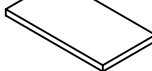
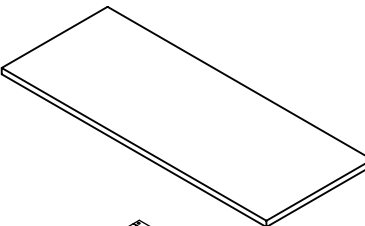
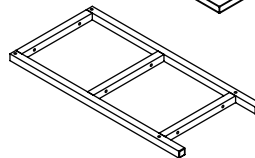
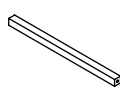
PARTS IDENTIFICATION

A	SHELF		4 PCS
B	TOP		1 PC
C	METAL FRAME		4 PCS
D	CROSSBAR		8 PCS

HARDWARE IDENTIFICATION

Z NO	DESCRIPTION	FIGURE	Q'TY
1	BOLT M6x44mm BLK		40 PCS
2	ALLEN WRENCH 4mm SR		1 PC

NOTE:

Phillips head screw driver is required in the assembly process; however, manufacturer does not provide this item.

STEP 1

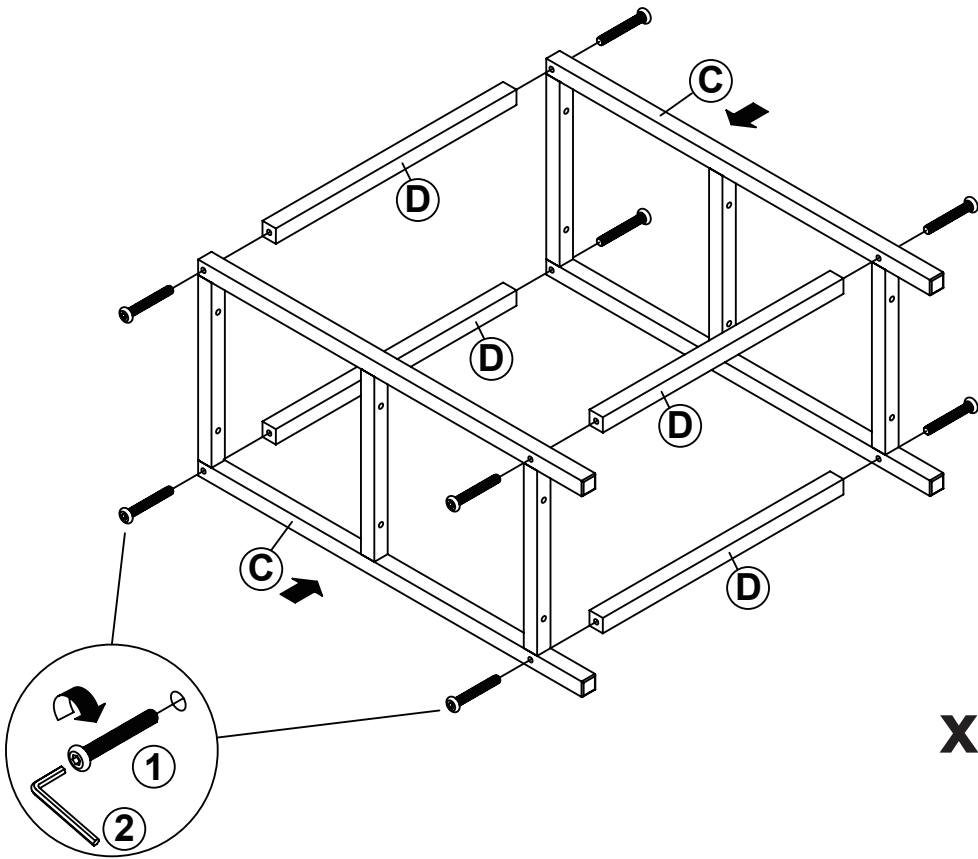
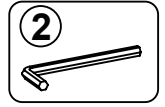
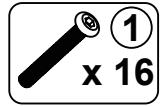

x 2

STEP 2

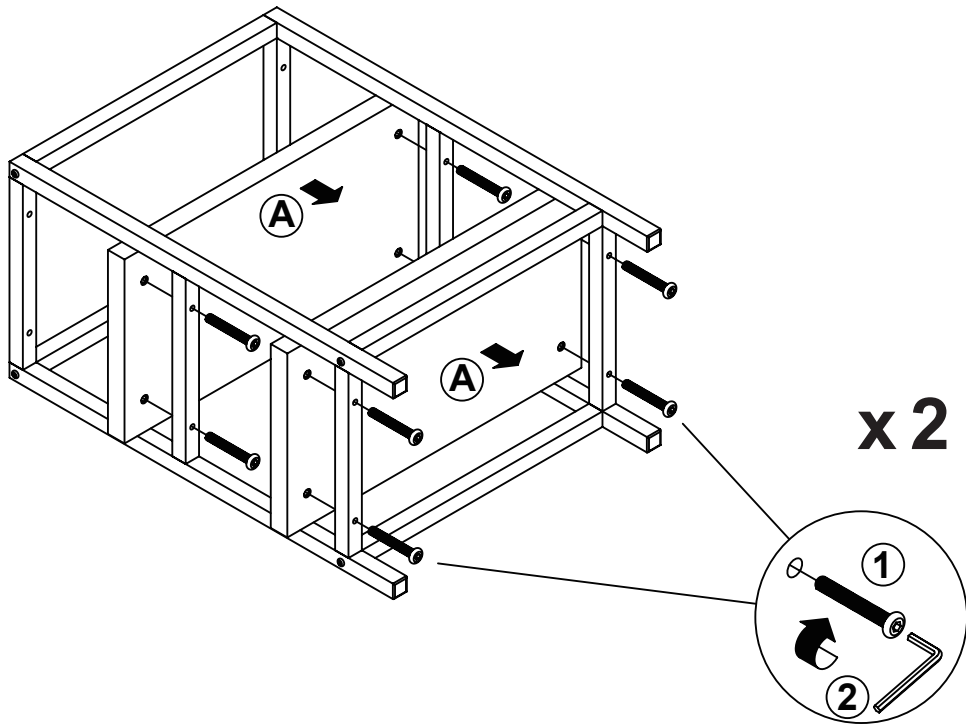
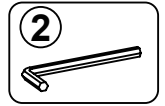
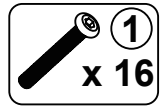

x 2

STEP 3

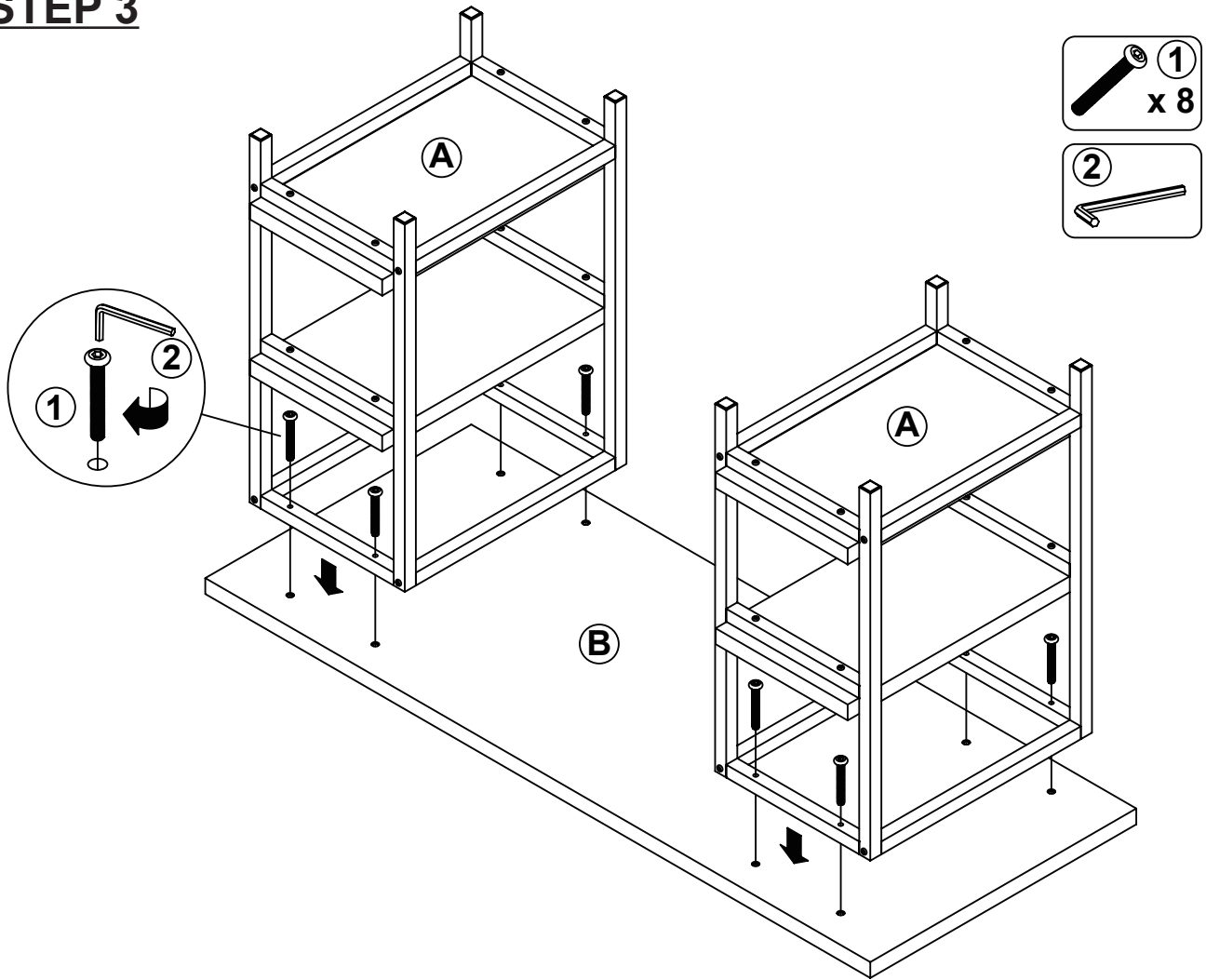

STEP 4

COMPLETE

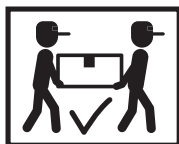
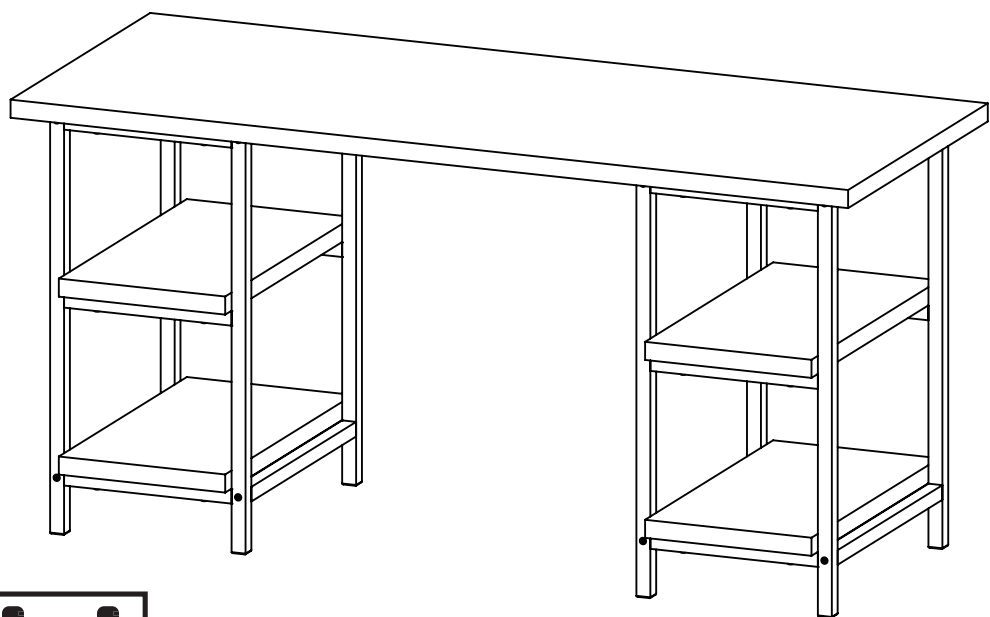

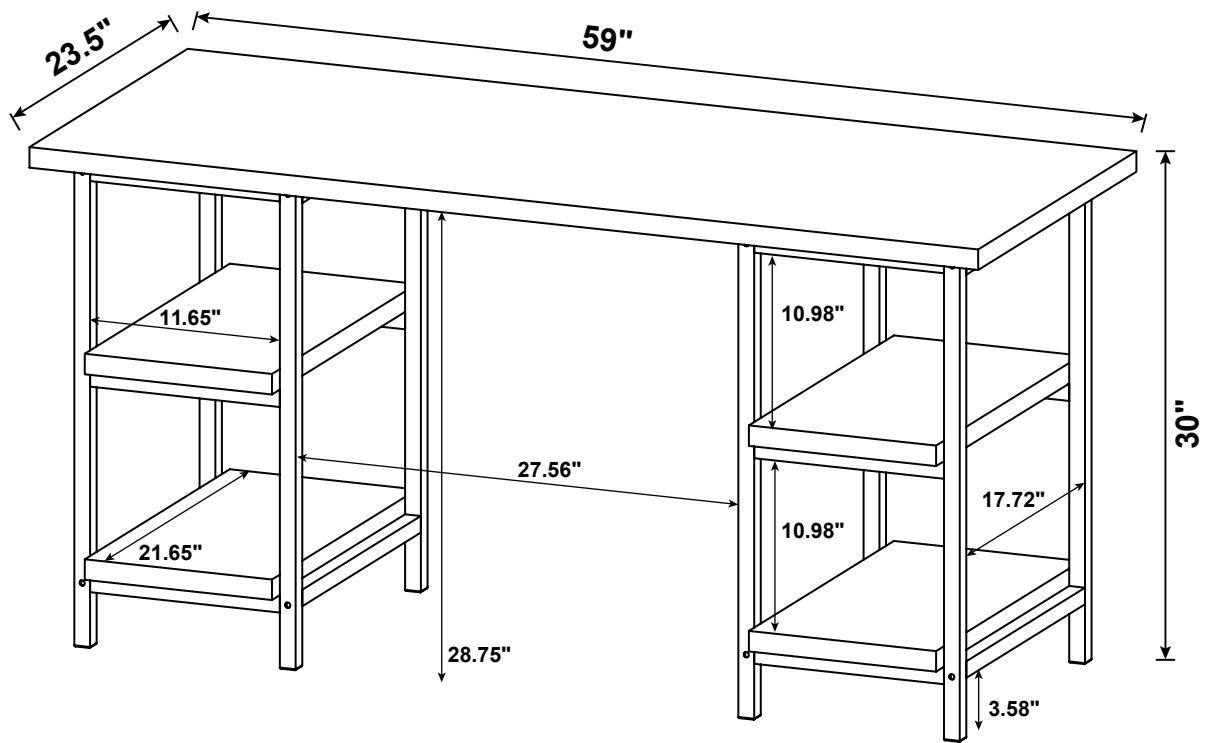

Note : Dimension tolerance $\pm 5\%$