

# Assembly Instruction

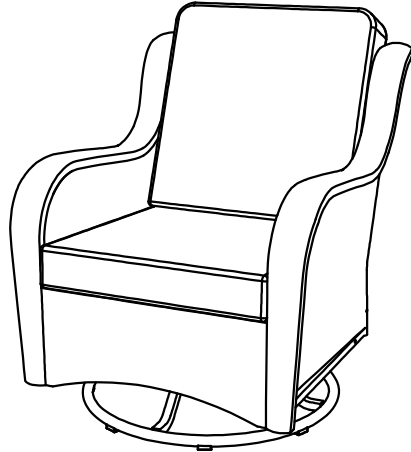







## Advice:

1. Power tools are suggested to be used during installation.
2. More than one person may be required to assemble this product.
3. The best advice is not tightening up any screws until the whole piece is assembled. If having difficulty aligning holes, loosen the screws already installed and readjust the armrest.
4. To avoid mess-up or mismatch, please use the hardware of each box to install the furniture in the same box.



Single Swivel Chair

## Parts List

NO.	Picture	Description	QTY	NO.	Picture	Description	QTY
SC-A		Chair Back	1	V		Screw (M6*35)	6
SC-B		Chair Seat	1	T		Screw (M6*45)	4
SC-D		Right Arm	1	N		Washer (M6)	10
SC-E		Left Arm	1	L		Allen Key	1

STEP 1

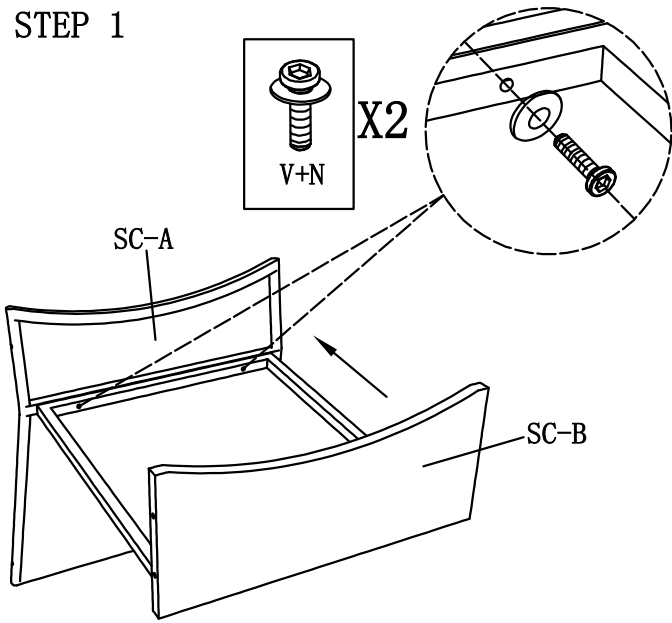

STEP 2

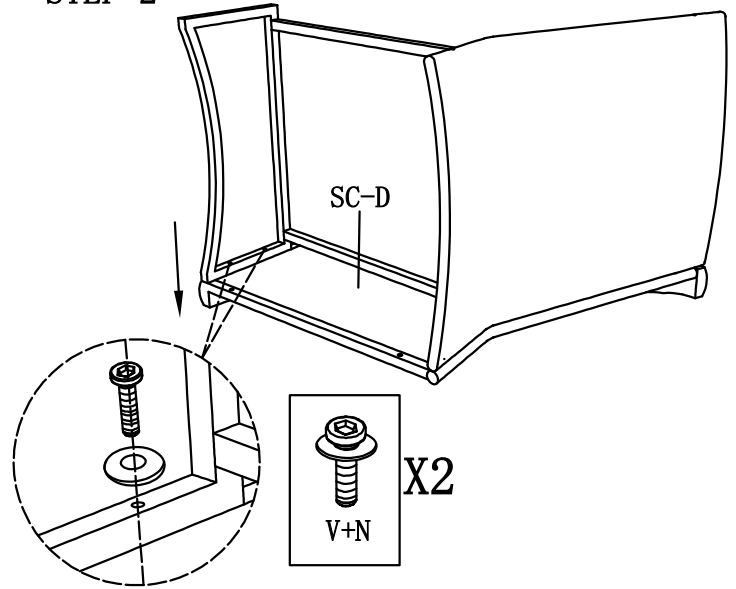

The best advice is not tightening up any screws until the whole piece is assembled.

STEP 3

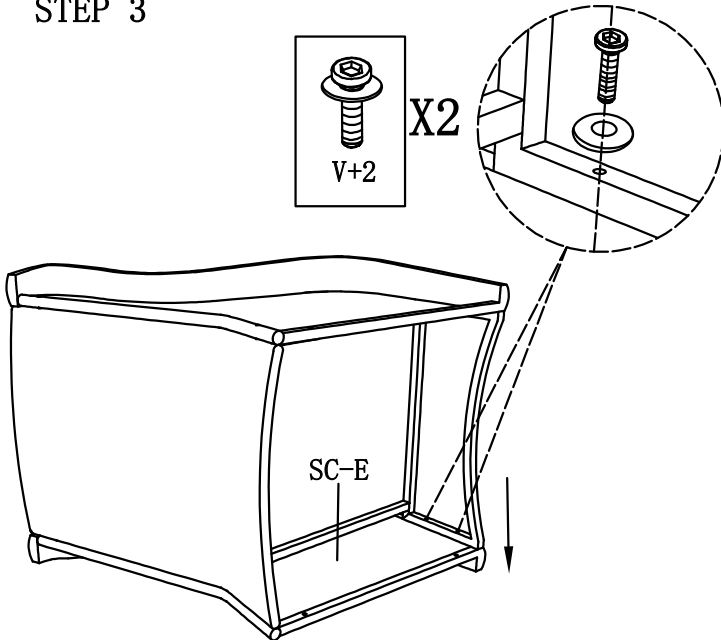

STEP 4

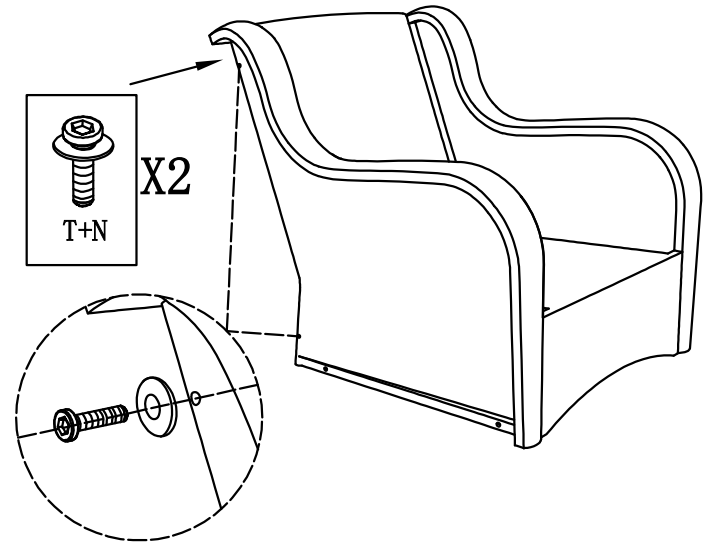

FINISH

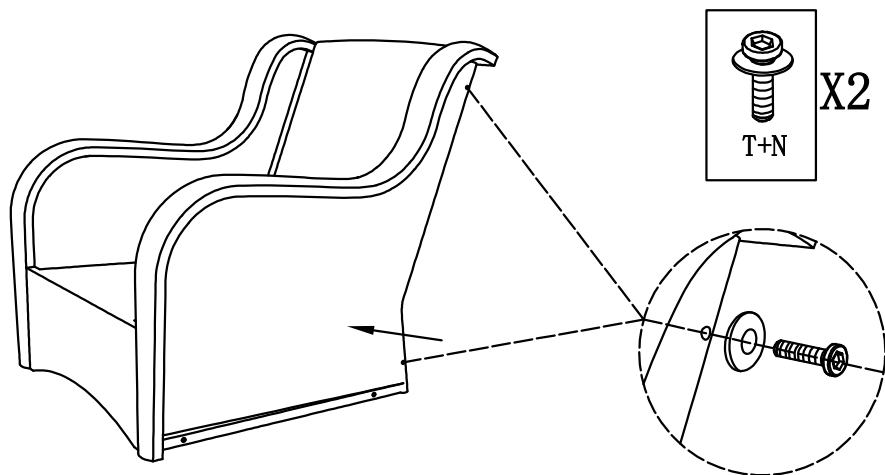

# Assembly Instruction

## Advice:

1. Power tools are suggested to be used during installation.
2. More than one person may be required to assemble this product.
3. The best advice is not tightening up any screws until the whole piece is assembled. If having difficulty aligning holes, loosen the screws already installed and readjust the armrest.
4. To avoid mess-up or mismatch, please use the hardware of each box to install the furniture in the same box.

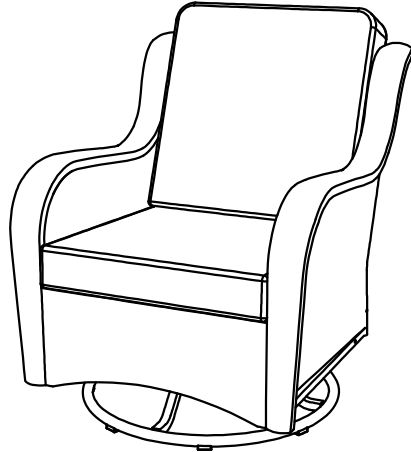

Single Swivel Chair

## Parts List

NO.	Picture	Description	QTY	SC-N			
				SC-N		Chair Base #7	1
SC-F		Back Cushion	1	A2		Screw (M6*20)	5
SC-G		Seat Cushion	1	V		Screw (M6*35)	8
SC-H		Chair Base #1	2	U		Screw (M6*40)	8
SC-I		Chair Base #2	4	T		Screw (M6*45)	8
SC-J		Chair Base #3	1	N		Washer (M6)	53
SC-K		Chair Base #4	1	H		Anti-slip Screw (M6)	24
SC-L		Chair Base #5	1	L		Allen Key	1
SC-M		Chair Base #6	1	J		Wrench (M6)	1

STEP 1

Ensure the protruding side faces outward when assembling (SC-I)

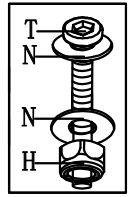

X4

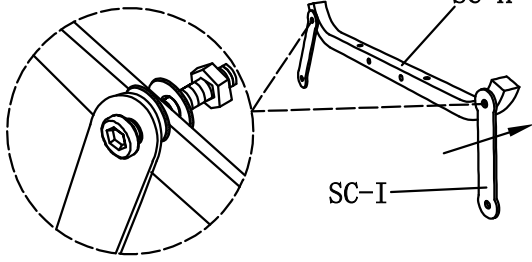

STEP 2

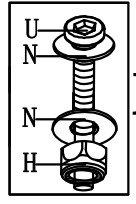
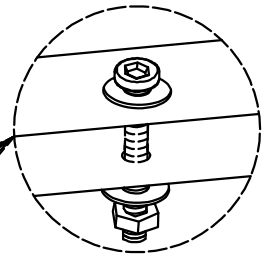
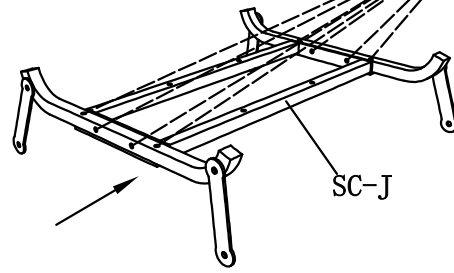

X8

The best advice is not tightening up any screws until the whole piece is assembled.

STEP 3

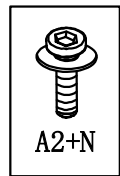
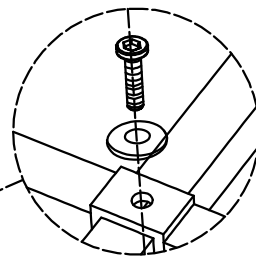
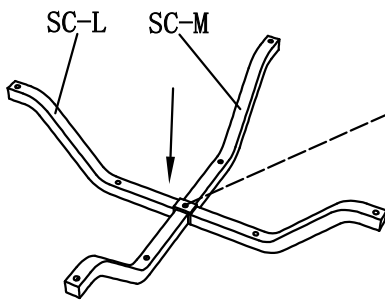

X1

Do not tighten this screw until (SC-N) is fully assembled

STEP 4

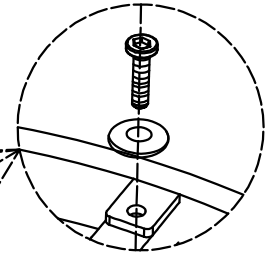
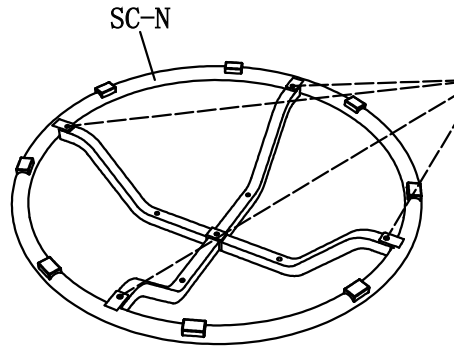

X4

Adjust the components to be parallel before proceeding with screw assembly

STEP 5

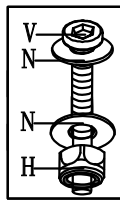
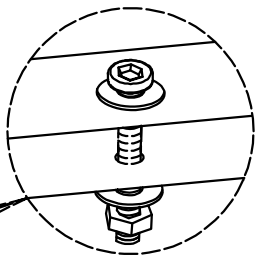
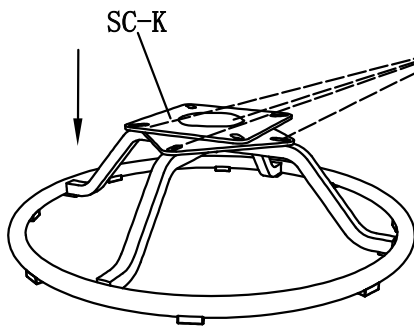

X4

STEP 6

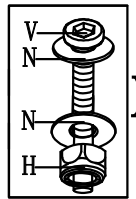
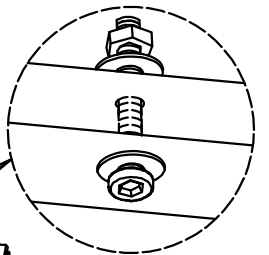
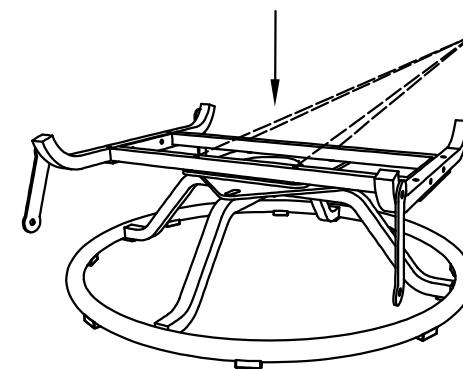

X4

STEP 7

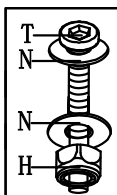
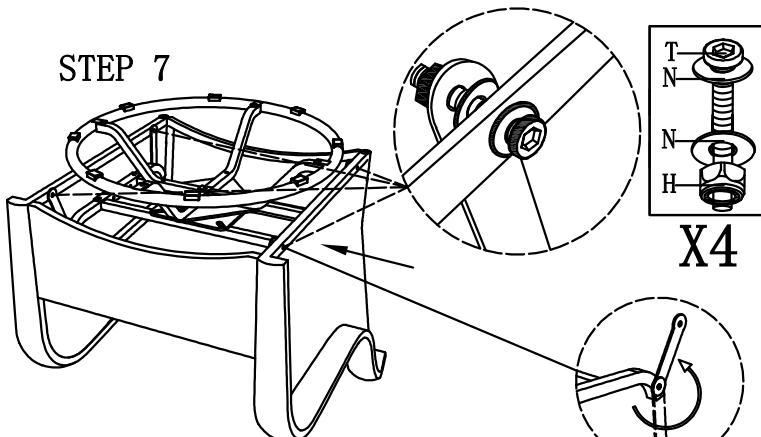

X4

After placing the base, rotate the pivot arm upwards to the appropriate position before proceeding with screw assembly

FINISH

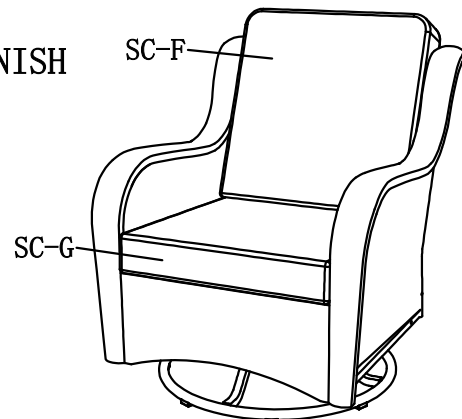

Please tap the cushions and wait 48 to 72 hours to fully rebound