

# Assembly | Asambla | Assemblage

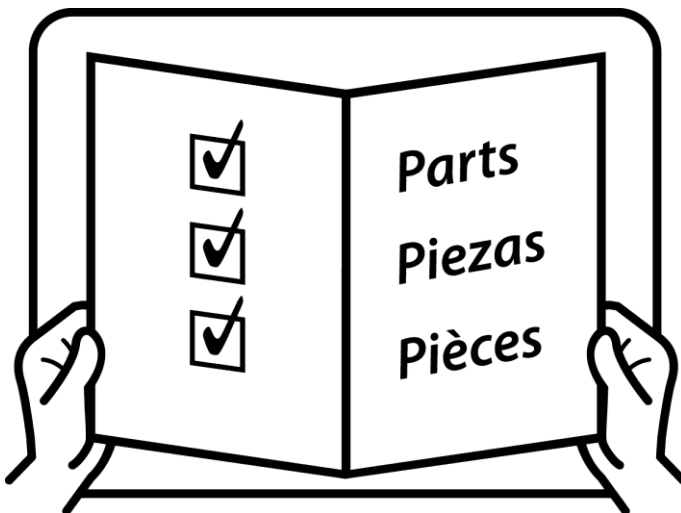

# Assembly | Asamblea | Assemblage

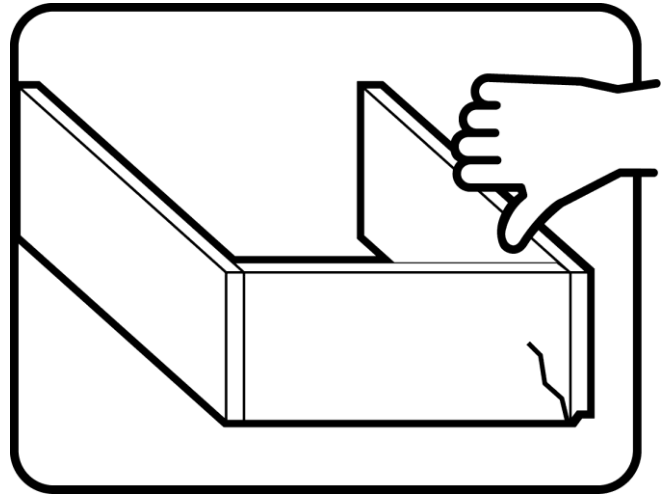
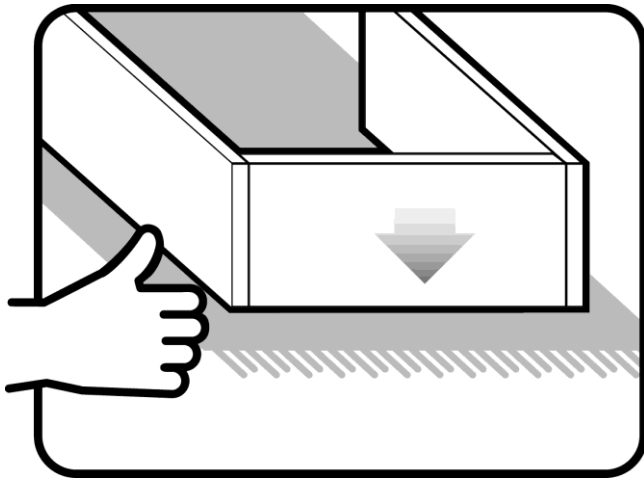
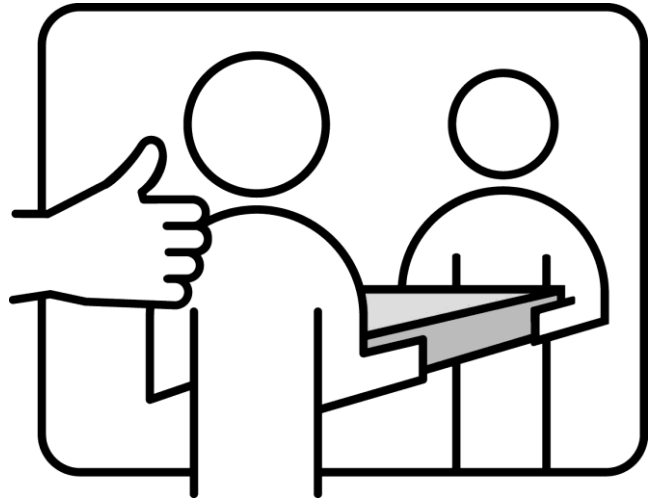
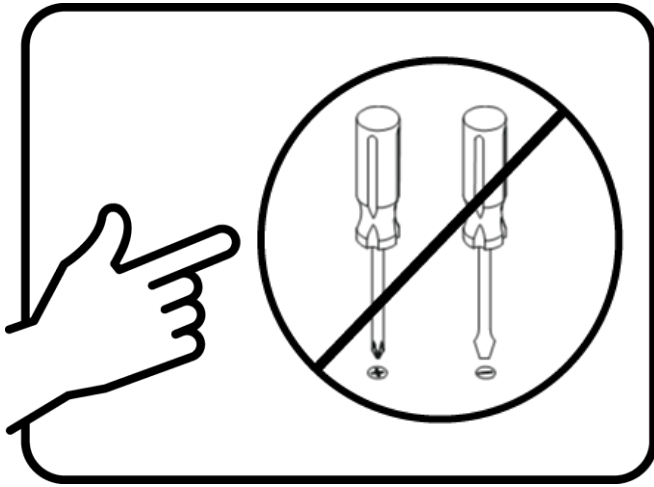

# Assembly | Asamblea | Assemblage

Techniques | Técnicas | Techniques

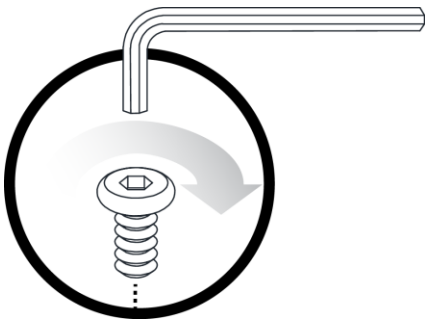

Care | Cuidado | Entretien



Safety | Seguridad | Sécurité



Note! | ¡Nota! | Remarque!



# Assembly | Asambla | Assemblage

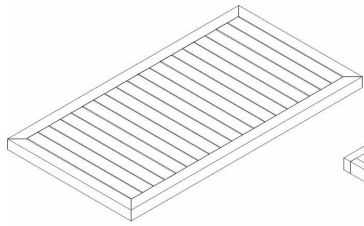

1 x (A)

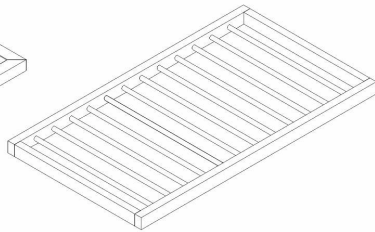

1 x (B)

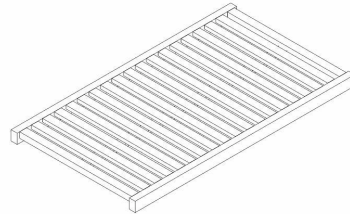

1 x (C)

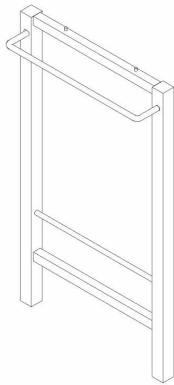

1 x (D)



1 x (E)



2 x (F)



2 x (G)

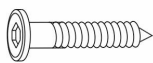

4 x (1)

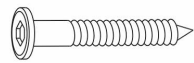

8 x (2)



2 x (3)



2 x (4)



2 x (5)



2 x (6)



2 x (7)



1 x (8)

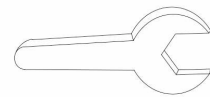

1 x (9)

# Assembly | Asambla | Assemblage

1

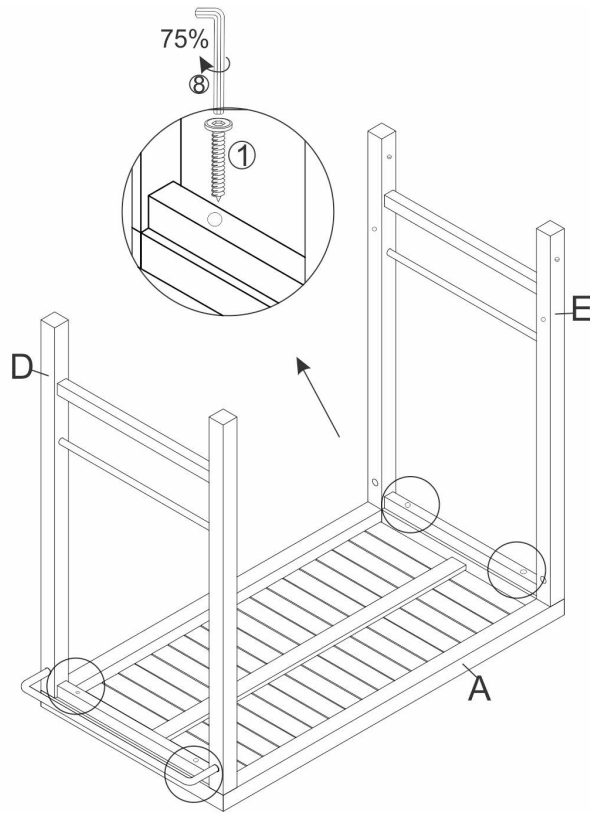

2

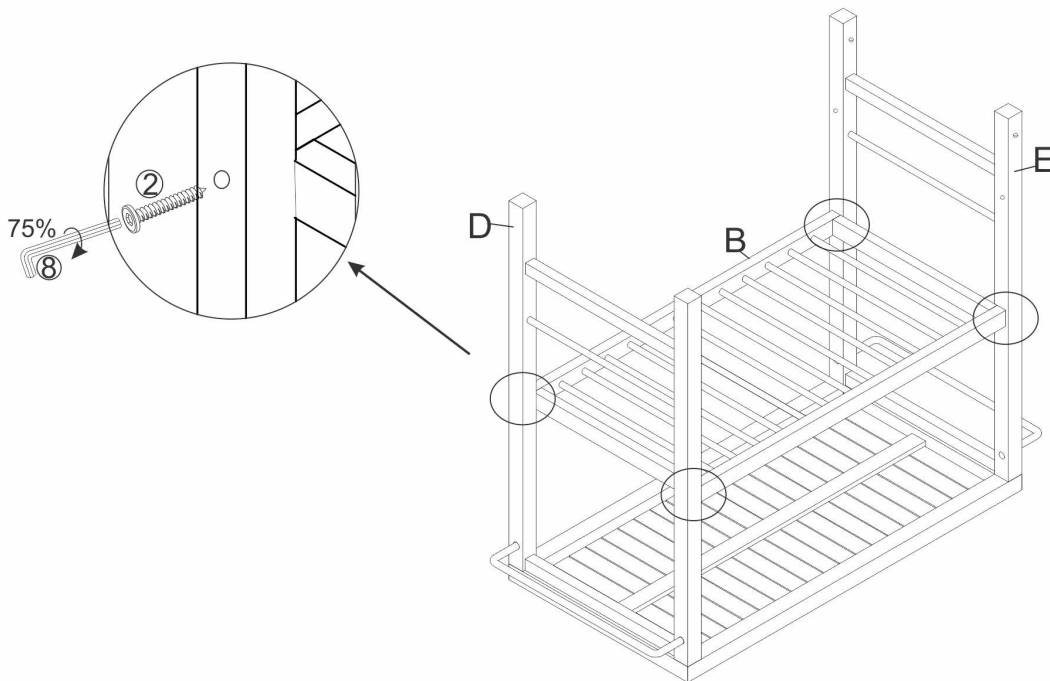

# Assembly | Asambla | Assemblage

3

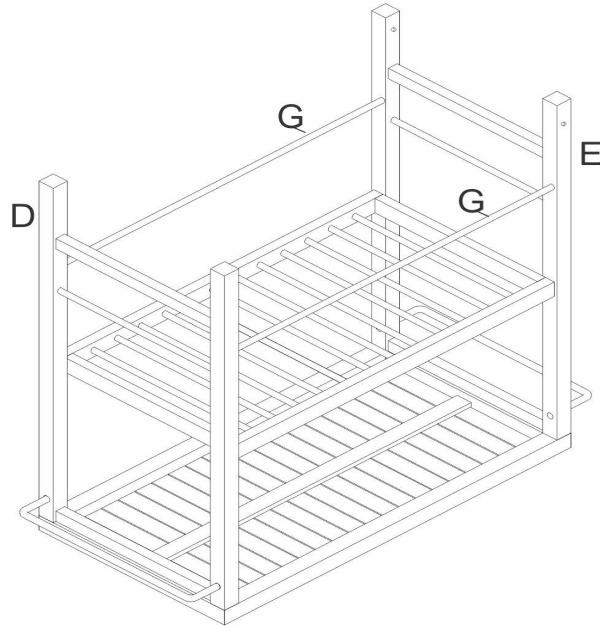

4

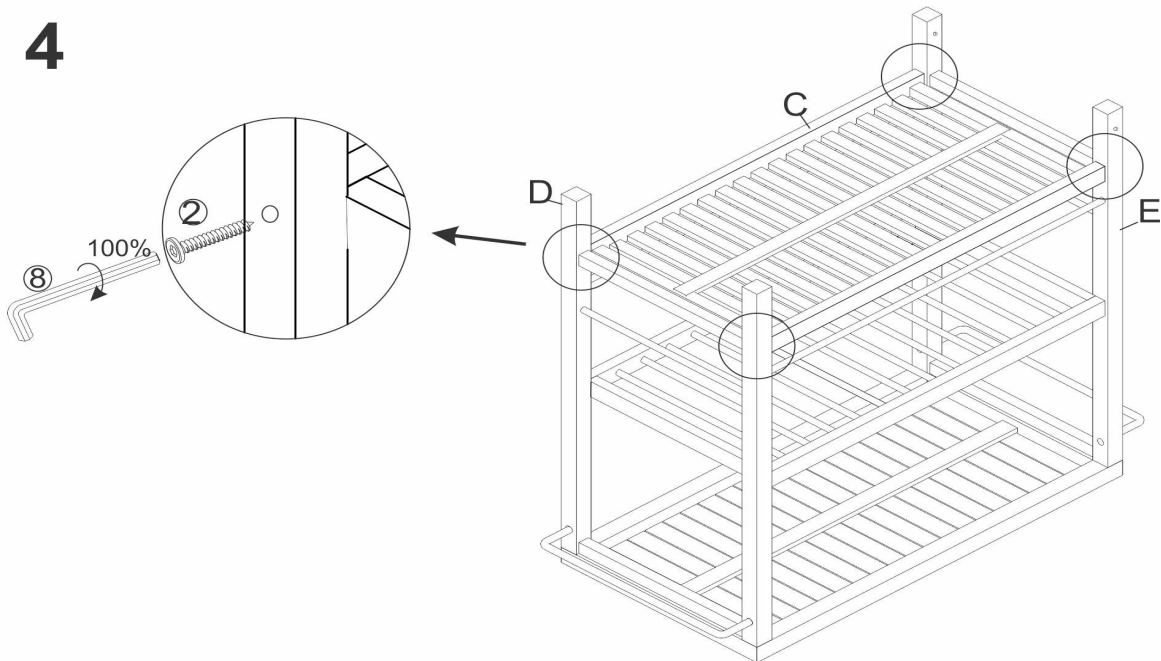

# Assembly | Asambla | Assemblage

5

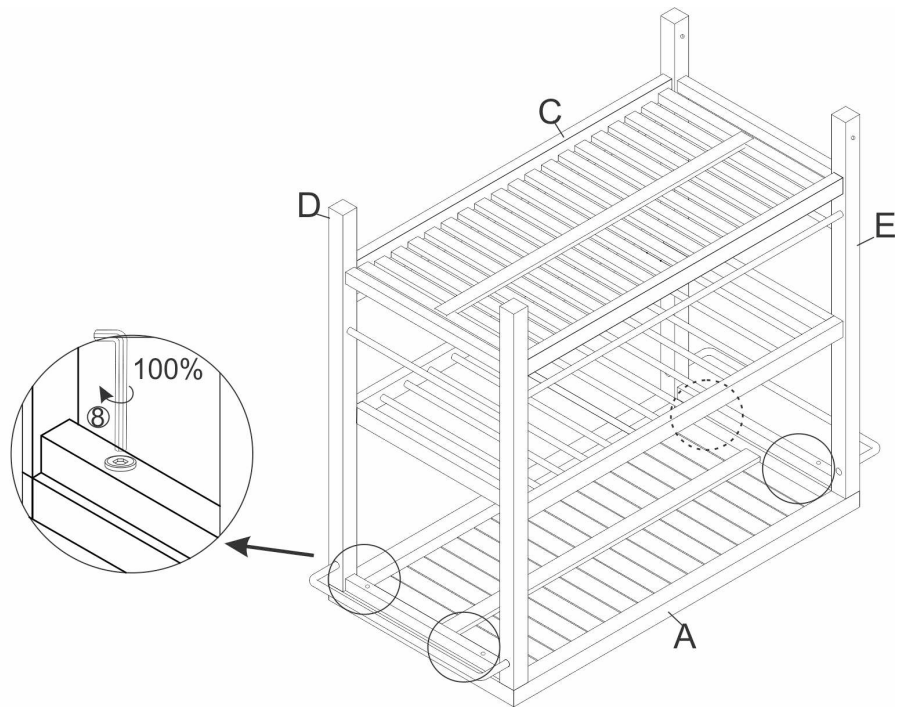

6

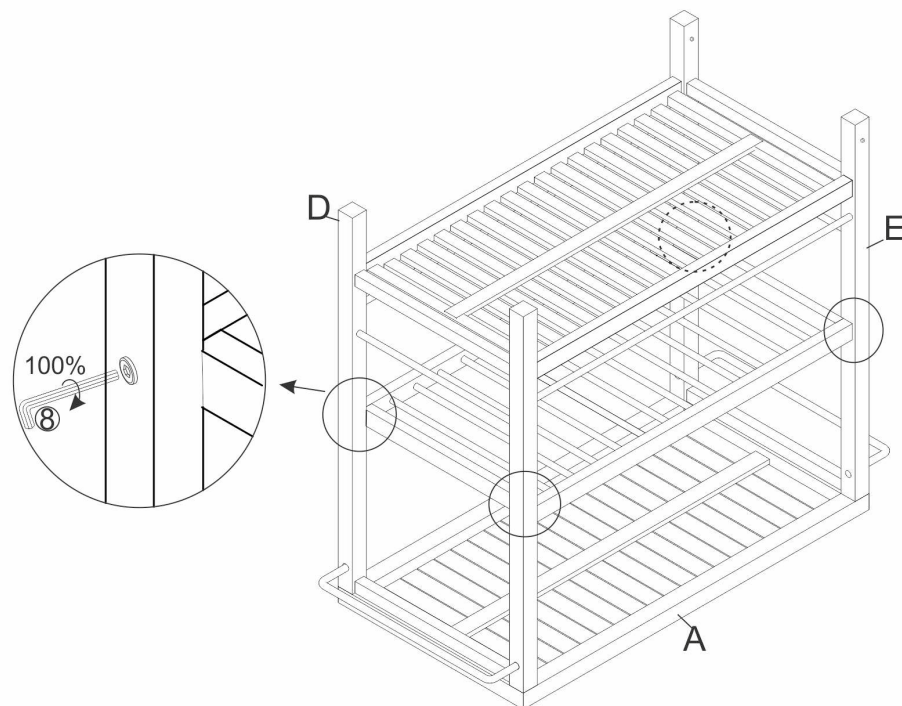

# Assembly | Asambla | Assemblage

7

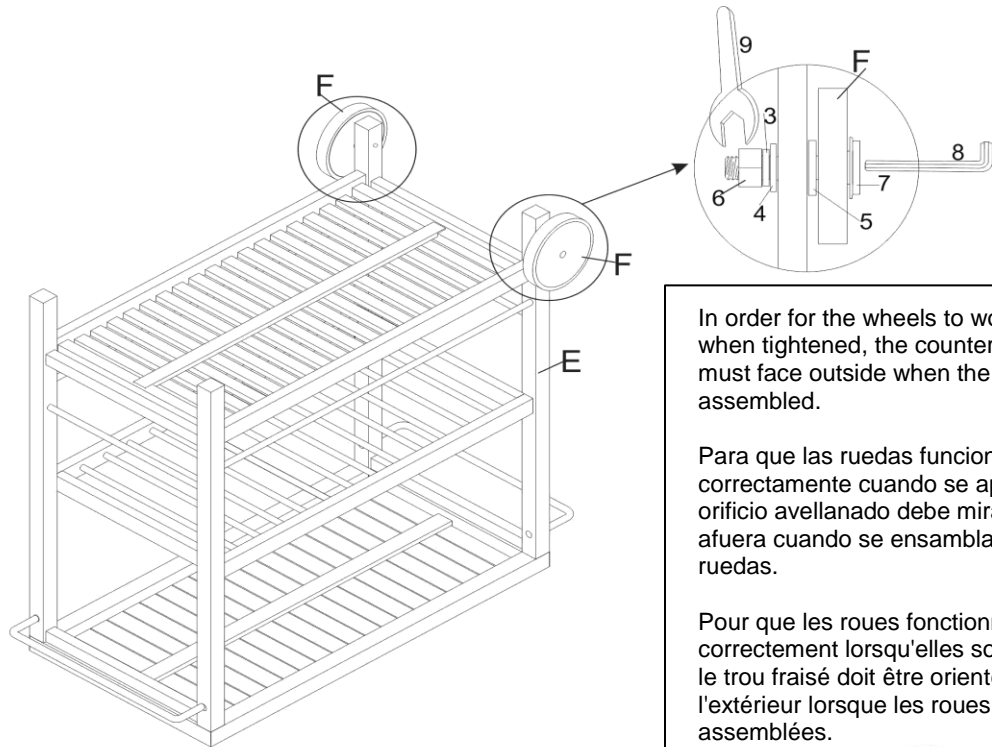

In order for the wheels to work properly when tightened, the countersunk hole must face outside when the wheels are assembled.

Para que las ruedas funcionen correctamente cuando se aprietan, el orificio avellanado debe mirar hacia afuera cuando se ensamblan las ruedas.

Pour que les roues fonctionnent correctement lorsqu'elles sont serrées, le trou fraisé doit être orienté vers l'extérieur lorsque les roues sont assemblées.

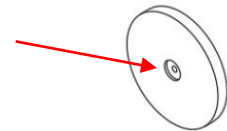

8

