

# ASSEMBLY INSTRUCTIONS

## Double Door Floor Cabinet

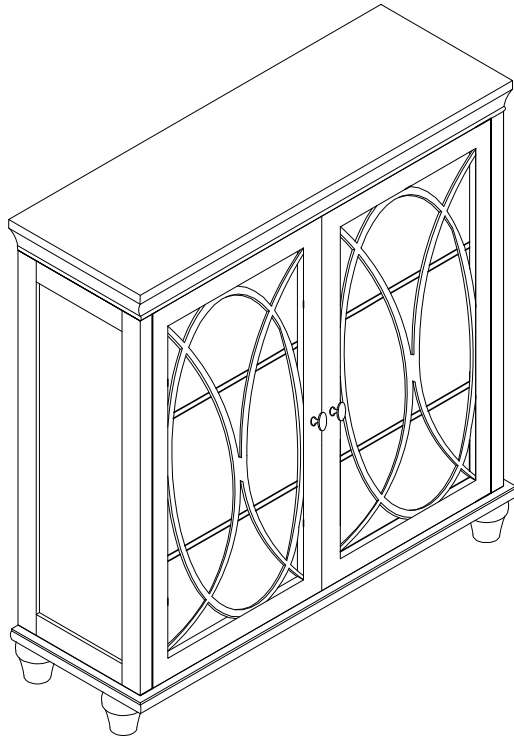

Please provide the following information when contacting for parts or questions: the name of the company you purchased from, the tracking number of the original package, and the original order date.

We offer free replacements for 1 year (purchase verification required). This replacement policy does not cover used/previously returned product or products sold by unauthorized third party vendors.

### ASSEMBLY INSTRUCTIONS-IMPORTANT

Carefully unpack & identify each component before attempting to assemble. Refer to parts list. Please take care when assembling the unit and always set the parts on a clean, soft surface. If you require any assistance with assembly, parts, please call the company you place order with or please email

### INSTRUCCIONES PARA ARMAR-IMPORANT:







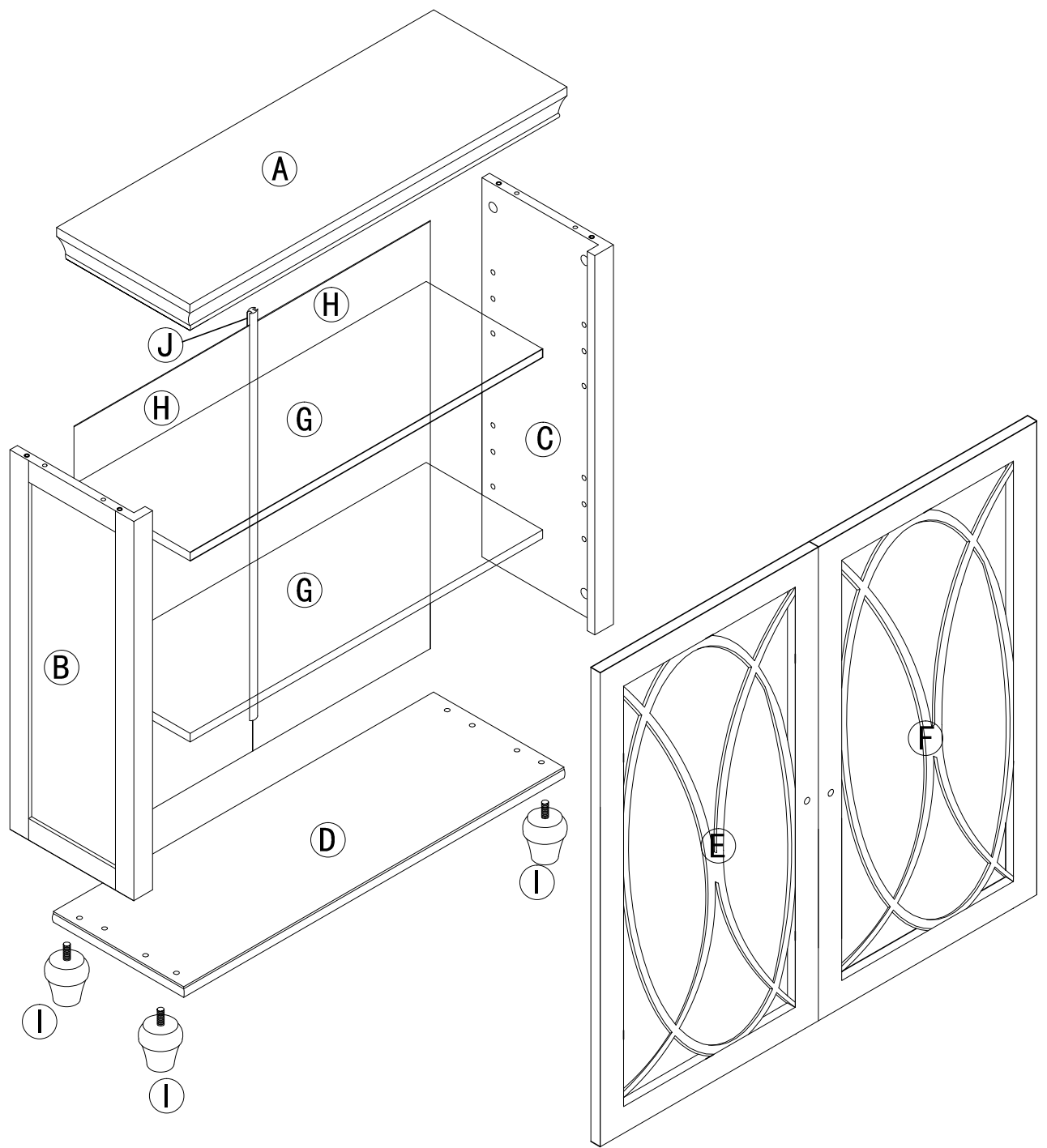

Desempaque cuidadosamente e identifique cada componente antes de tartar de empezar su ensambladura. Verifique la lista de partes. Por favor tenga cuidado cuando arme la unidad y siempre coloque las piezas sobre una superficie plana, suave y limpia. Si necesita ayuda con el armado, envíe un correo electzórico

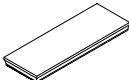
### DIRECTIVES DE MONTAGE-IMPORTANT:

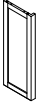
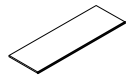
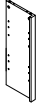

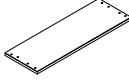





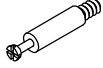

Avant de commencer l' assemblage, déballez délicatement toutes les pièces et repérez-les sur la liste des pièces. Procédez avec soins durant l' assemblage et posez toujours les pièces sur une surface proper, douce et lisse. sie vouo plait e-mail

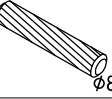

# COMPONENTS

PART	FIGURE	DESCRIPTION	QTY	PART	FIGURE	DESCRIPTION	QTY
A		TOP PANEL	1PC	F		RIGHT DOOR	1PC
B		LEFT SIDE PANEL	1PC	G		GLASS SHELF	2PCS
C		RIGHT SIDE PANEL	1PC	H		BACK PANEL	2PCS
D		BOTTOM PANEL	1PC	I		LEG	4PCS
E		LEFT DOOR	1PC	J		PLASTIC BAR	1PC

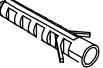
# HARDWARE & TOOLS

PART	FIGURE	DESCRIPTION	QTY	PART	FIGURE	DESCRIPTION	QTY
1		CAM BOLT	8PCS	7		HANDLE	2PCS
2	 $\phi 15 \times 12$	CAM LOCK	8PCS	8		BOLT	2PCS
3	 $\phi 8 \times 30$	WOODEN DOWEL	8PCS	9		FIX BELT	1PC
4	 $\phi 3 \times 12$	SCREW	8PCS	10	 $\phi 4 \times 25$	SCREW	2PCS
5		SHELF PIN	8PCS	11		ANCHOR	1PC
6	 $\phi 3 \times 12$ D=7	SCREW	16PCS	12		WASHER	2PCS

## TOOL NEEDED:



**PHILIPS SCREWDRIVER REQUIRED  
- NOT INCLUDED**

## SUGGESTION:

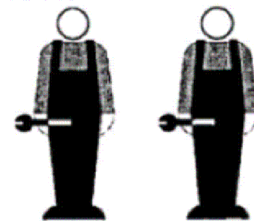

**TWO PEOPLE FOR ASSEMBLING**



## WARNINGS:

1. DO NOT LET ANY SHARP OBJECTS TOUCH OR RUB THE SURFACE OF THE PRODUCT.
2. WHEN ASSEMBLING, DO NOT LET CHILDREN PLAY AROUND THE WORKING AREA.
3. PLEASE CONFIRM ALL PARTS ARE CORRECT BEFORE STARTING THE ASSEMBLY PROCESS.
4. DO NOT TIGHTEN ALL BOLTS AND SCREWS COMPLETELY UNTIL THE ENTIRE UNIT HAS BEEN ASSEMBLED AND SET UP.

# 1

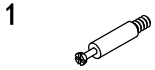

4 PCS



4 PCS



4 PCS

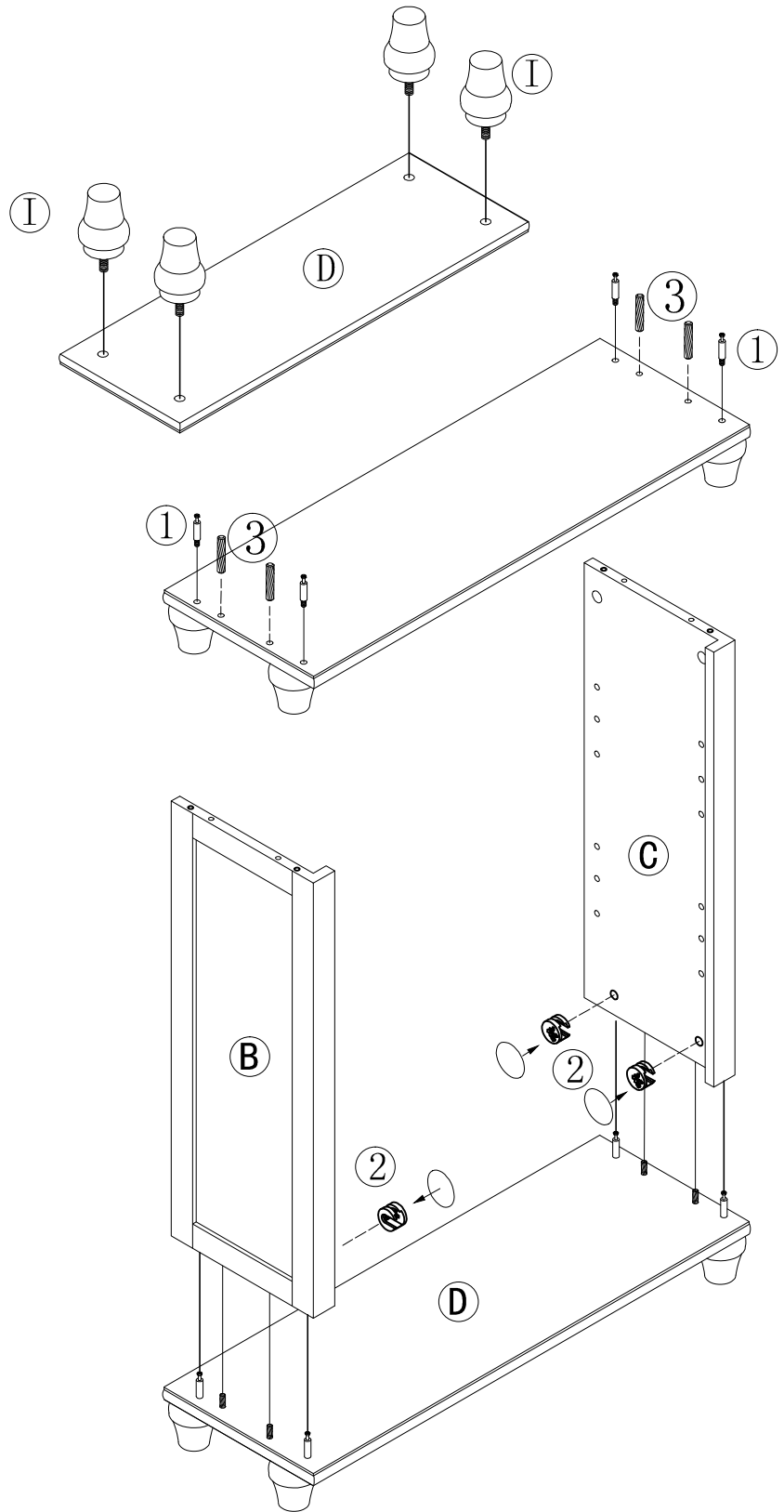

## STEP 1:

1. Screw Legs I into panel D.
2. Screw cambolts (1) and insert dowels (3) to panel D.
3. Attach panel D to side panels B & C and secure with camlocks (2).

# 2

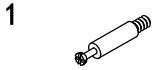

4 PCS



4 PCS

Ø15\*12



4 PCS

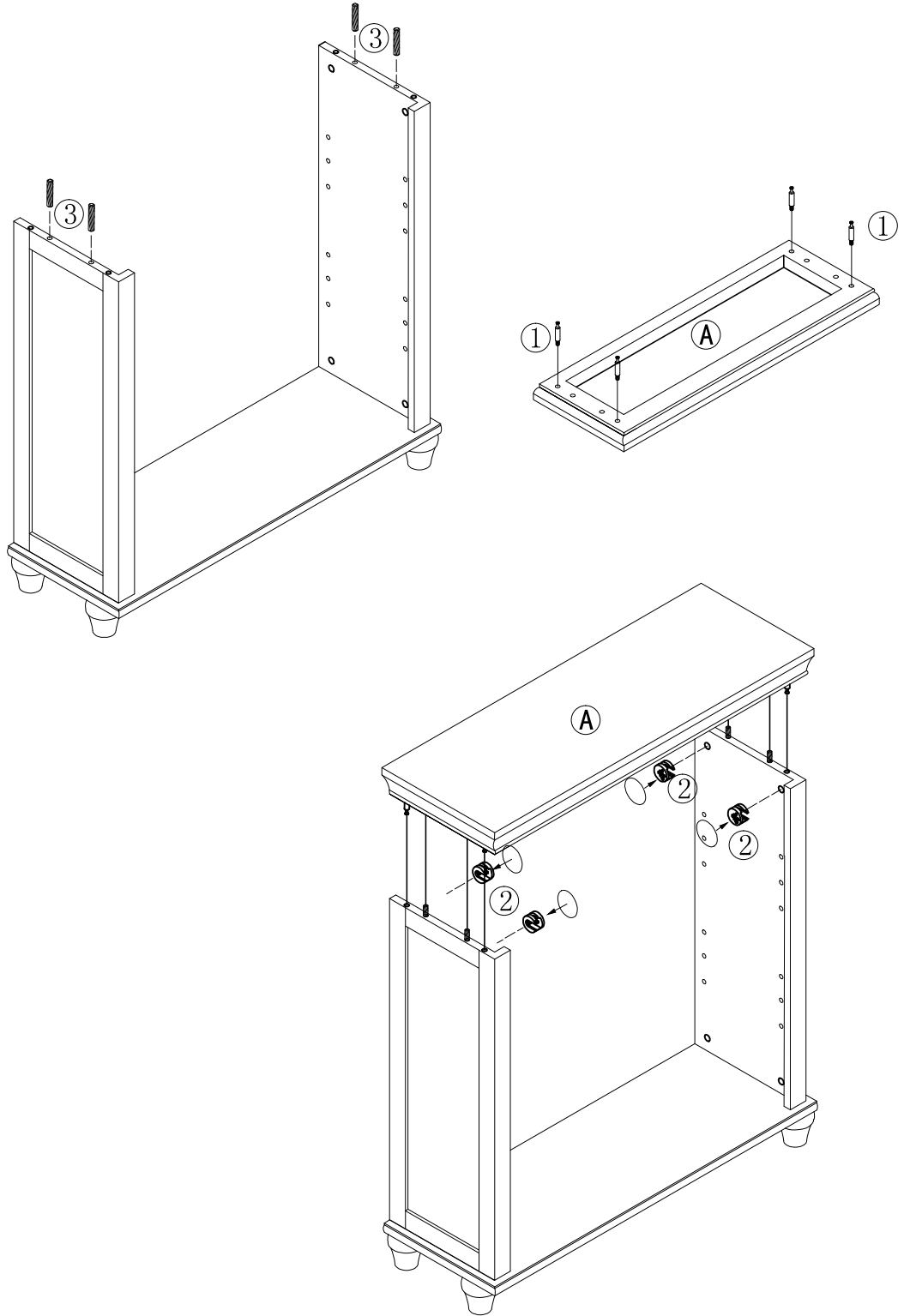

## STEP 2:

1. Insert dowels (3) to the tops of panels B & C .
2. Screw cambolts (1) to panel A.
3. Attach panel A to panels B & C and secure with camlocks (2).

# 3

6



16 PCS

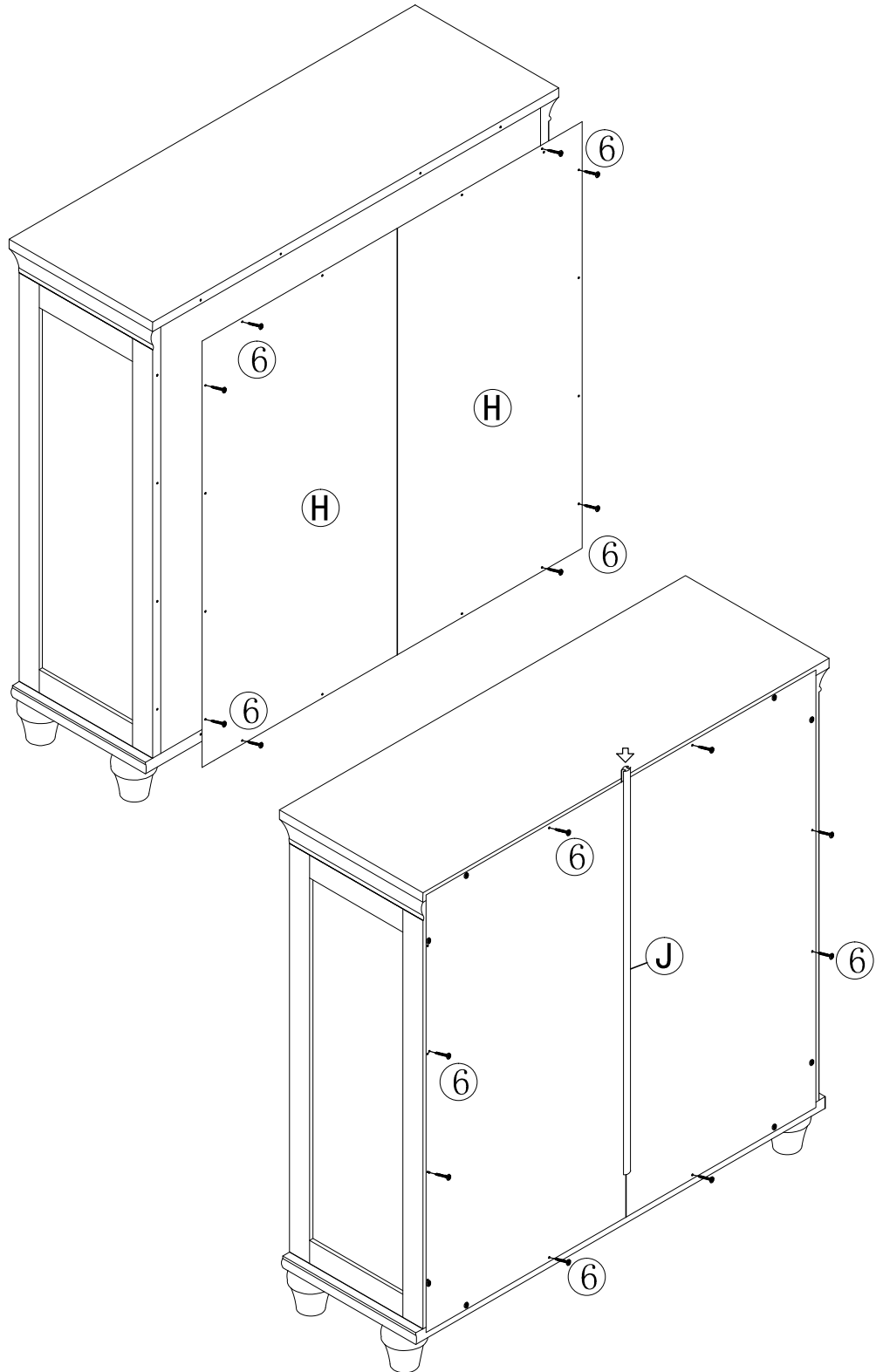

## STEP 3:

1. Attach panels H to the back of the cabinet & secure the four corners with screws (6).
2. Insert plastic bar J between the two panel Hs and finish securing the panels with screw (6).

# 4

4



8 PCS  $\varnothing 3 \times 12$

5



8 PCS

7



2 PCS

8



2 PCS

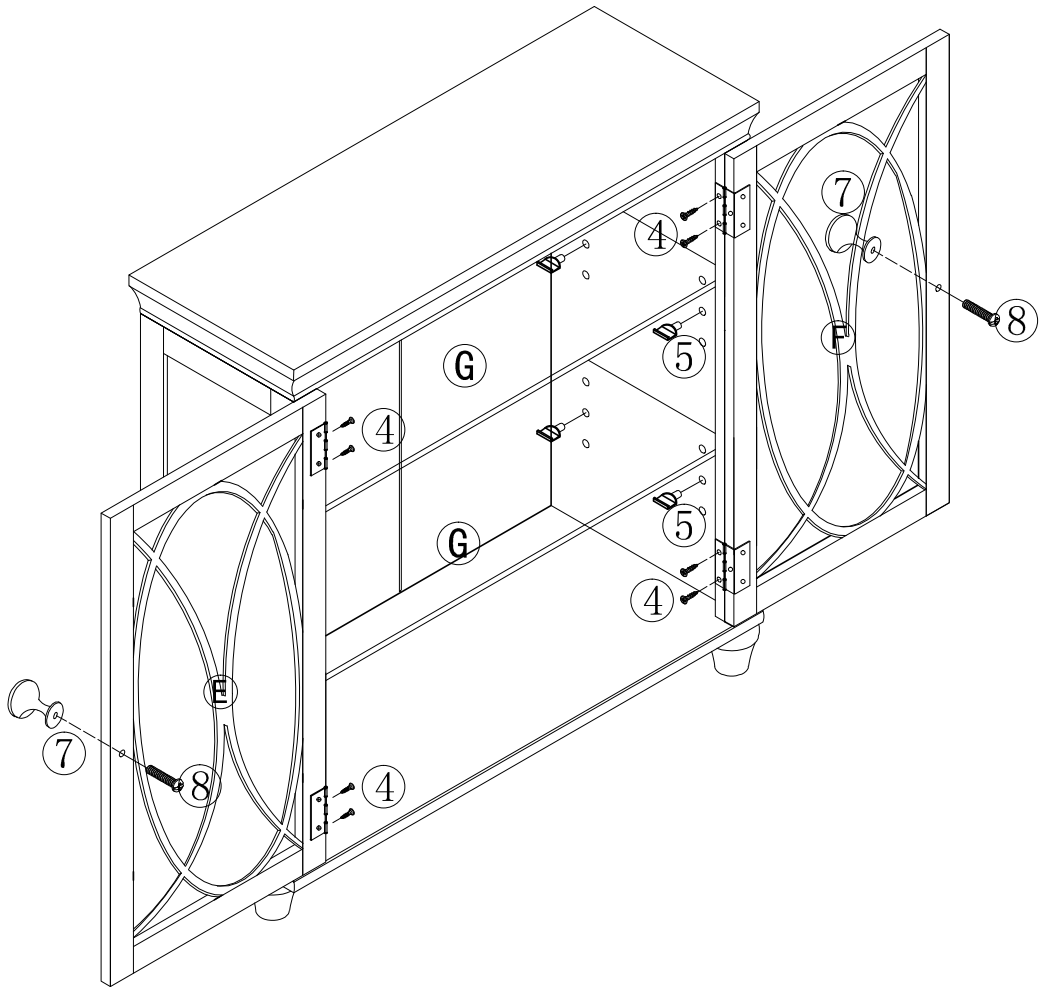

## STEP 4:

1. Attach handles (7) to doors E & F with bolts (8).
2. Attach doors E & F to panels B & C with screws (4).
3. Insert shelf pins (5) in panels B & C and rest the glass shelf G on the shelf pins.



# 5

9



1 PC

10



2 PCS

ø4\*25

11



1 PC

12



2 PCS

