

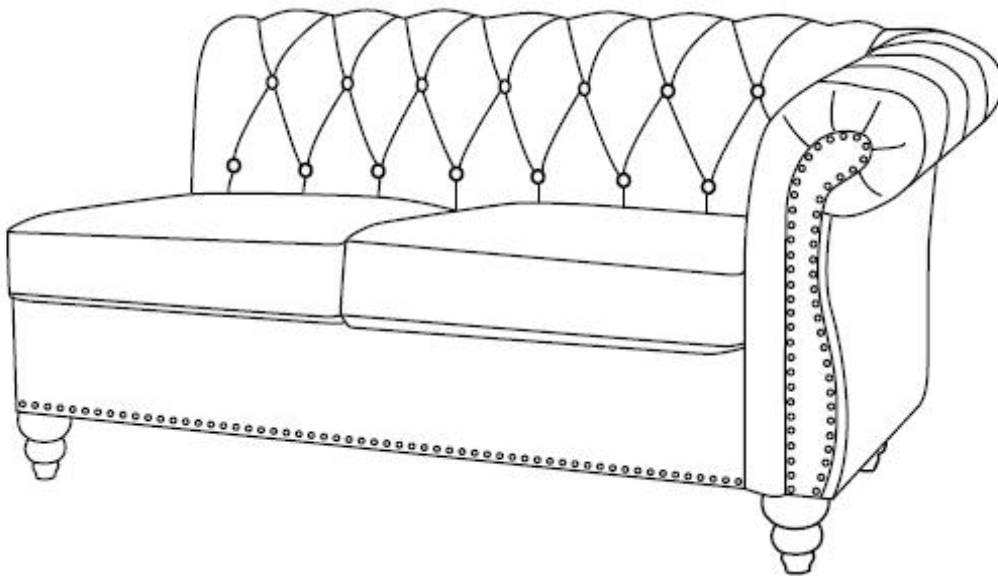





Assembly Instructions

Note: Please help to read my instruction before you ready to assemble.

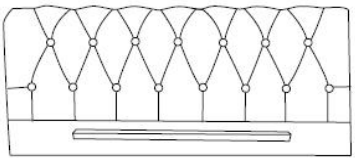
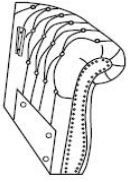





Right Arm Sofa

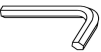

Part List

A		Backrest	1
B		Right Armrest	1
C		Side Panel	1
D		Seat	1
E		Front Rail	1
F		Seat Cushion	2
G		Leg	4

Hardware

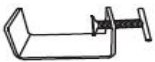
①		Plastic Washer	7
②		Allen Wrench	1
③		Bolt(M8*25MM)	3
④		Bolt(M8*50MM)	4
⑤		Flat Washer	6
⑥		Spring Washer	6
⑦		Iron Stand	1
⑧		Connecting Piece	1

Assembly Preparation

All Including:

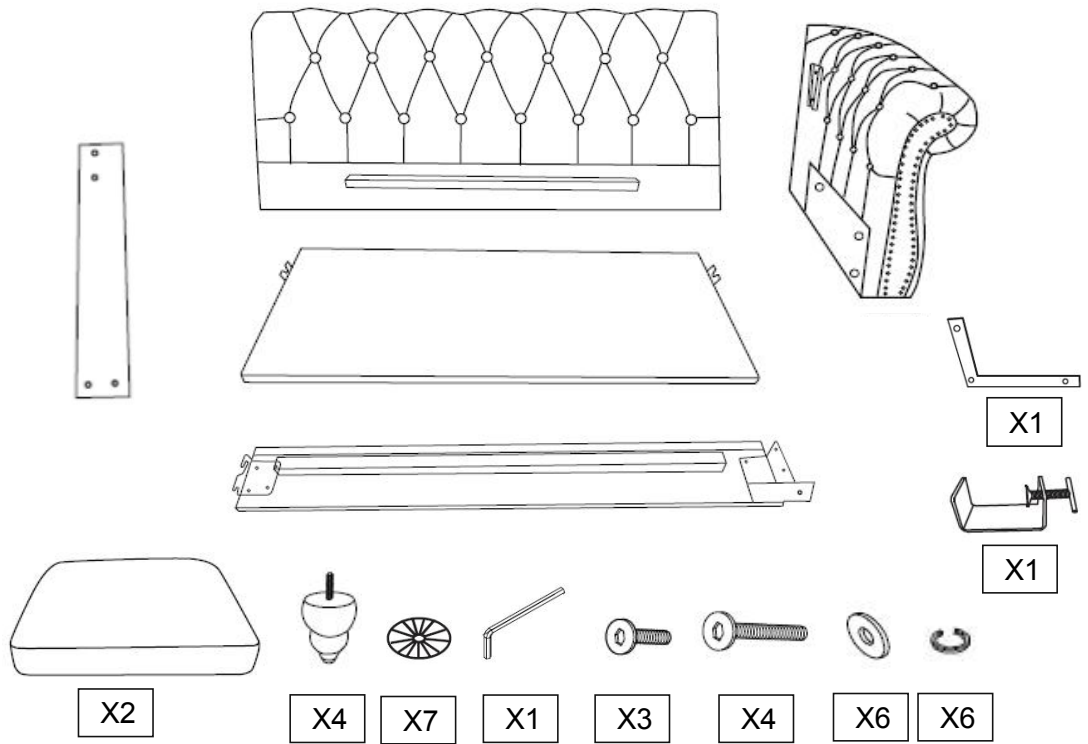

Assembly Steps

OVERVIEW

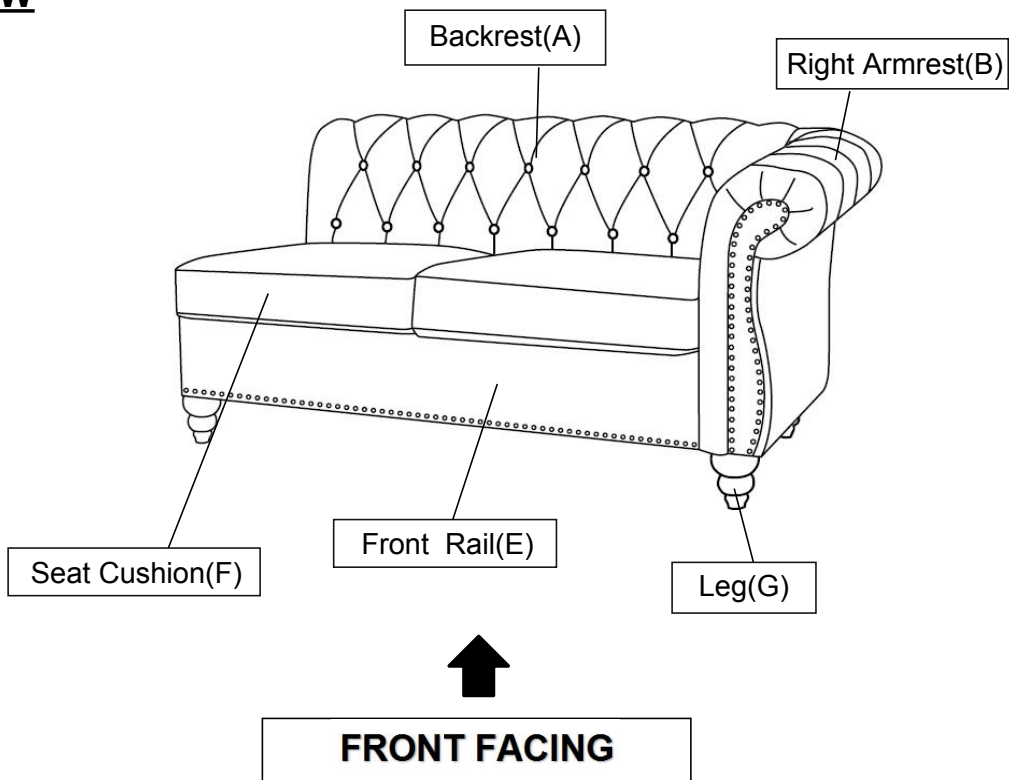

This Right Arm sofa has multiple parts and may require up to 30 minutes to assemble. To give you an overview of the Right Arm sofa, the above picture is to help you put the various parts into perspective. Please read through the instructions below to familiarise yourself with the parts and steps before assembly.

Note: It is recommended that you have an adult partner to assist during the entire assembly process.

Step 1

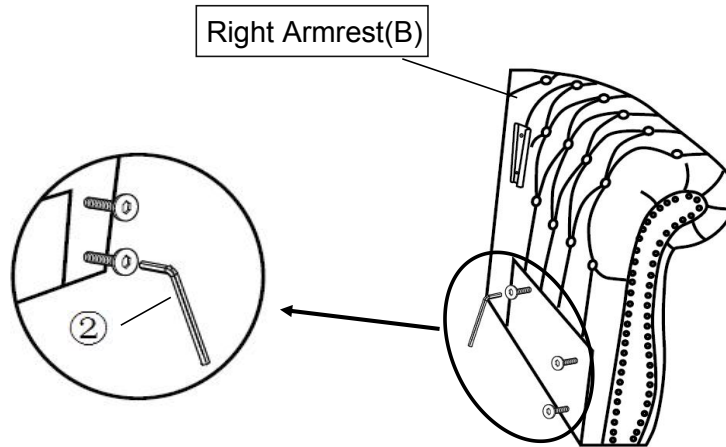

Open the carton and place all the parts on a clean, non-marring surface.
Loosen the 3 bolts in Right Armrest(B) around an inch by Allen Wrench(2).

Step 2

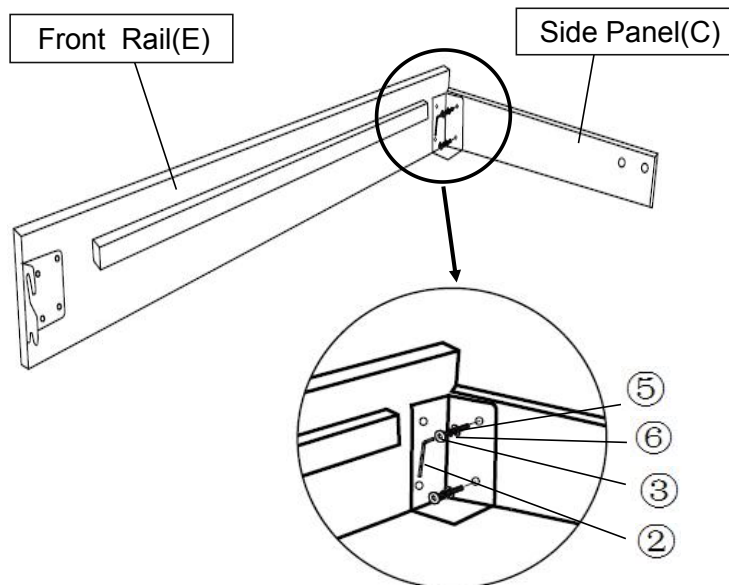

Attach the Side Panel(C) to the Front Rail(E), using Bolts(3), Spring Washer(6) Flat Washer(5), with Allen Wrench(2), turning clockwise until tight.

Step 3

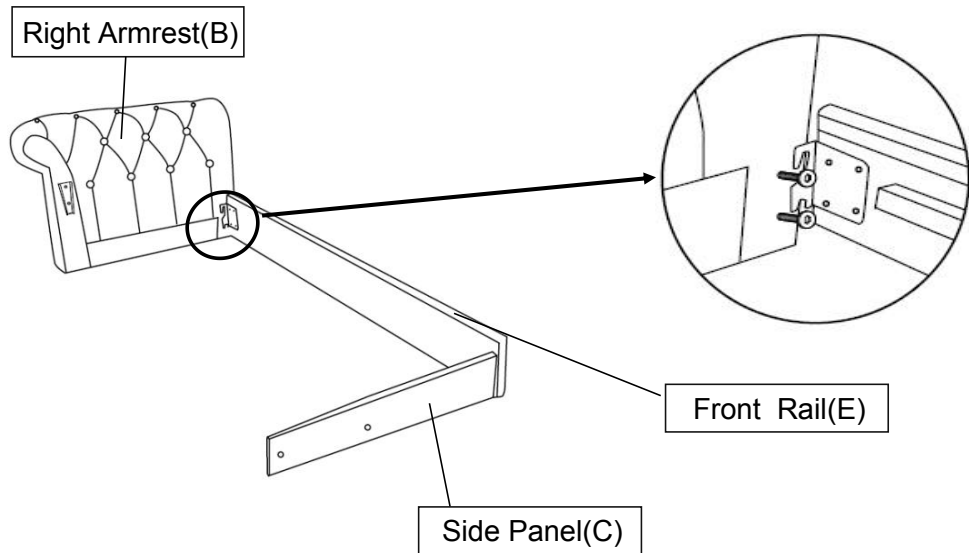

With the assistance of your partner, slide the hook in the end of Front Rail (E) into the bolts on the Right Armrest (B) as shown above.

Step 4

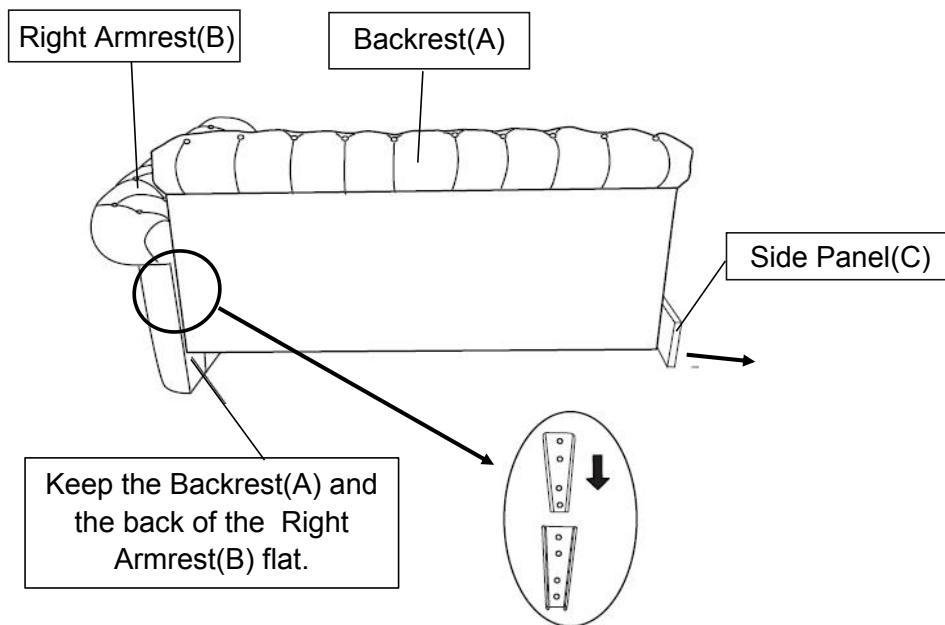

Slide the Tapered Connectors on the Backrest (A) into the Tapered Connectors on the Right Armrest (B) as shown in the picture.

Note: Make sure the Tapered Connectors on Backrest (A) locked into the Tapered Connectors on the Right Armrest (B).

Keep the Backrest (A) and the back of the Right Armrest (B) flat.

Assistance from an adult partner is necessary for this assembly process.

During this assembly process - do exercise caution. You may need to use your hand to press down and or pave away the padded surface to facilitate the 'slip and slide' assembly.

Caution: Ensure that your fingers do not get caught or pinched in the assembly process.

Step 5

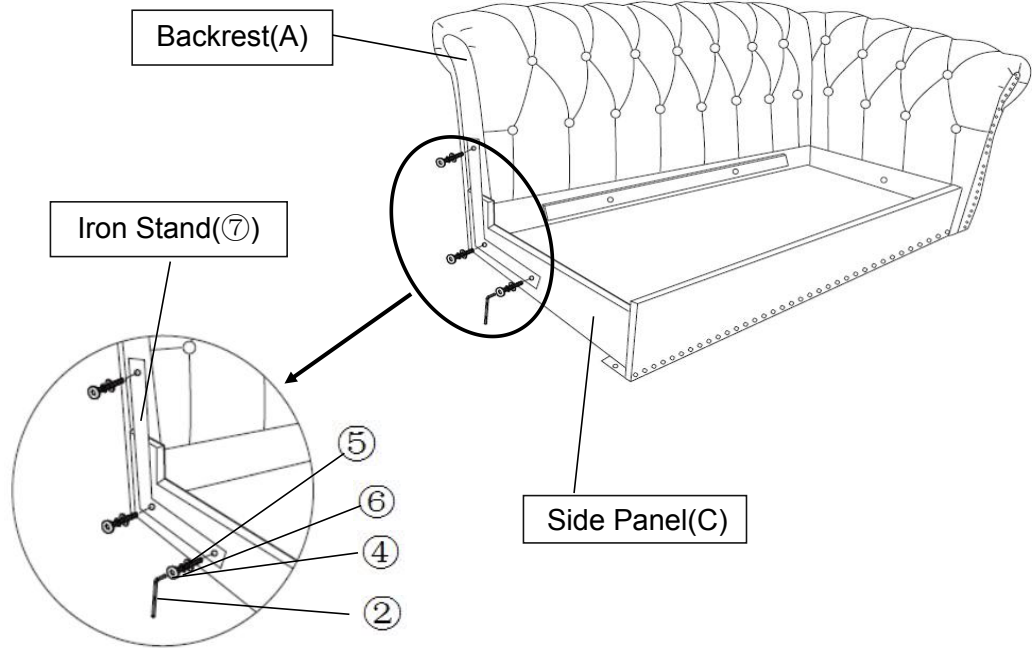

Attach the Iron Stand(7) to the Backrest(A) and Side Panel(C), using Bolts(4), Spring Washer(6), Flat Washer (5), with Allen Wrench(2). turning clockwise until tight.

Step 6

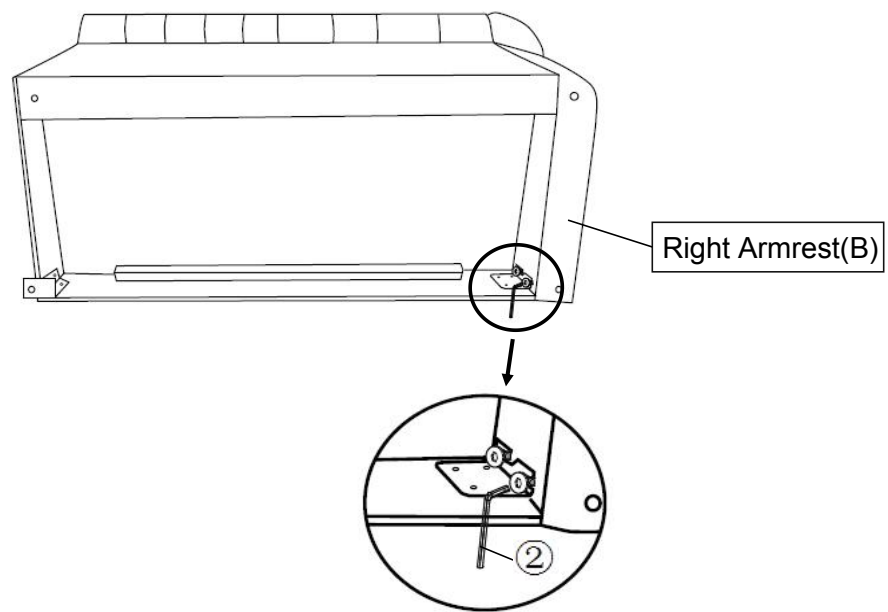

Change tilt and lay the Right Arm Sofa another side onto a flat surface. Tighten the Bolts at the bottom of Right Armrest(B) by Allen Wrench(2) as pictured above. Tighten the Bolts fully in a sequential manner.

Step 7

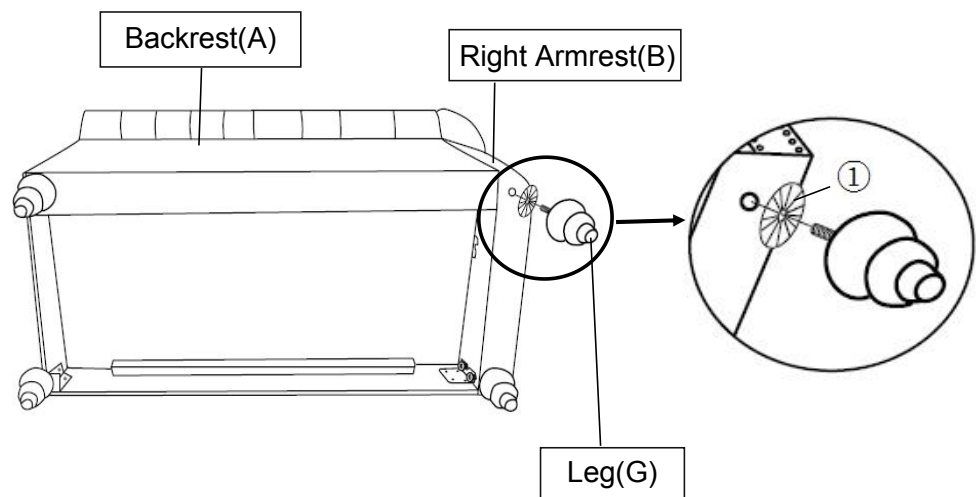

Install the Leg(G) at the bottom of Right Armrest(B) and Backrest(A) by placing Plastic Washer(①) on the threaded stem. Then insert threaded stem into the threaded mounting position at the bottom of Right Armrest(B) and Backrest(A). Tighten by turning the Leg clockwise then position sofa right side up.
Note: The use of Plastic Washer(①) are OPTIONAL and are especially useful to help alleviate slight wobbles. Some Legs may need more than one whilst some legs may not need any.

This Step only can be used when a Three Seater Sofa has been completely assembled.

Step 8

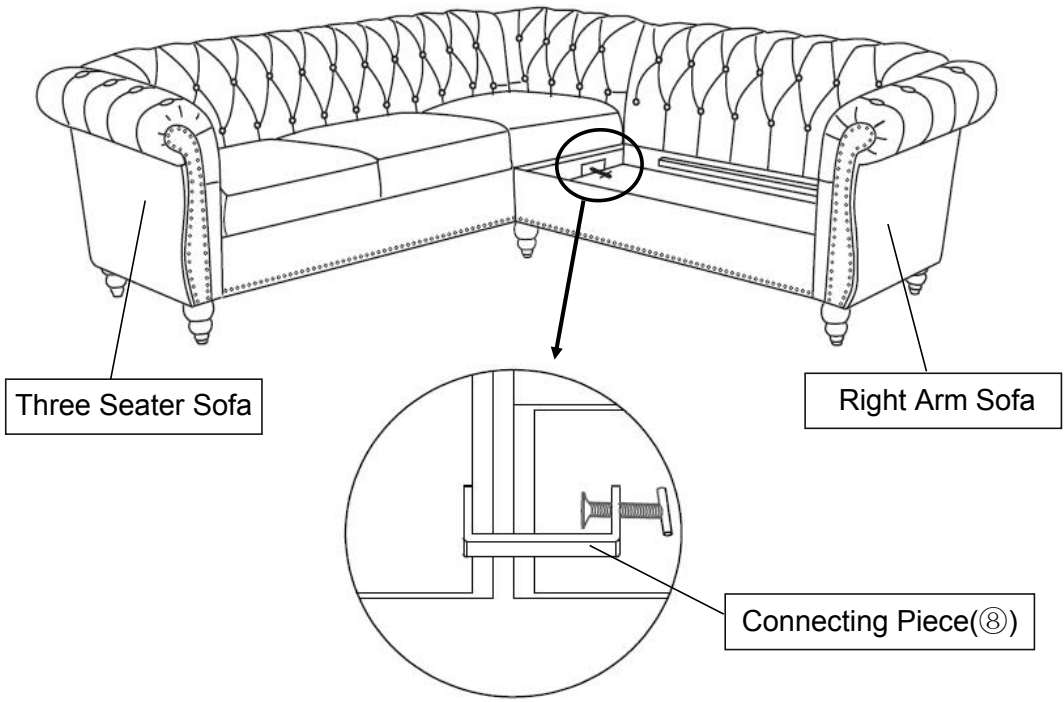

Place the Right Arm Sofa close to right side of Three Seater Sofa as picture showed above. Using Connecting Piece(8) to lock this two sofas together by turning clockwise until tight. **DO NOT OVER TIGHTEN.**

Step 9

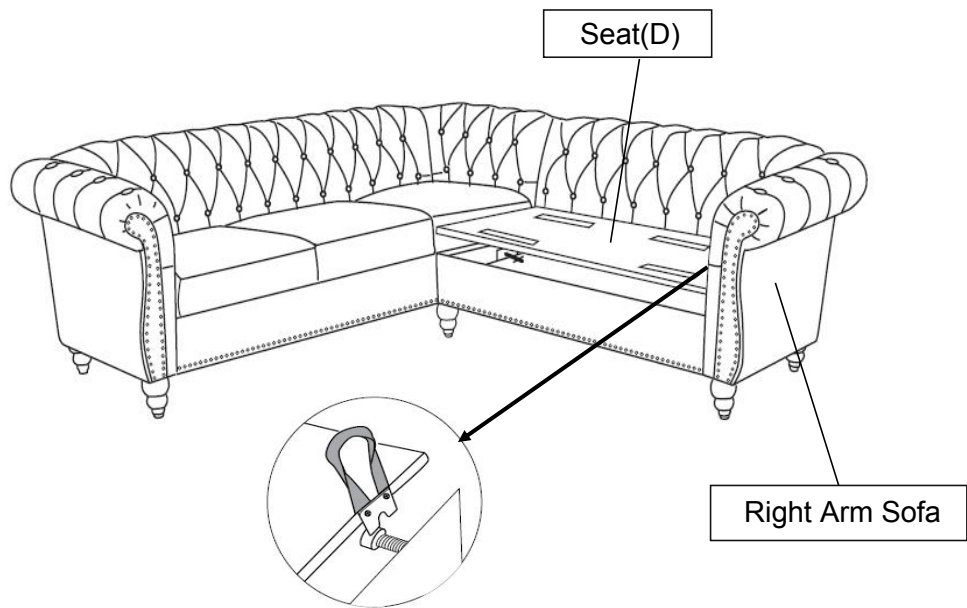

Put the Seat(D) on the Right Arm Sofa.

Step 10

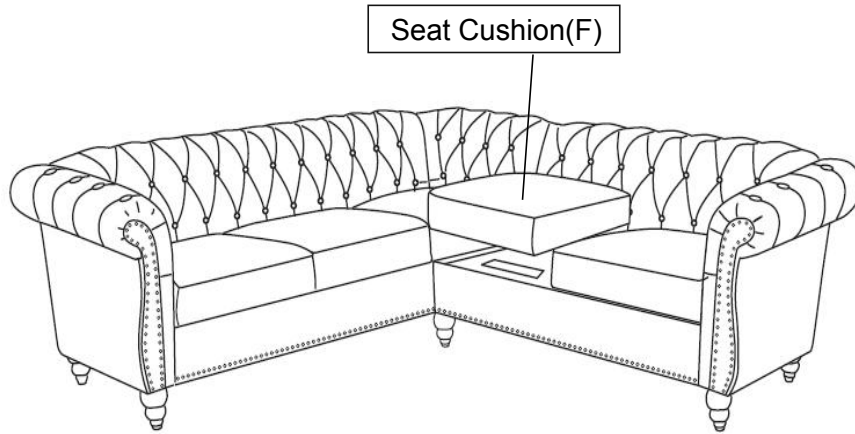

Put the Seat Cushion(F) on the Right Arm Sofa.

Step11

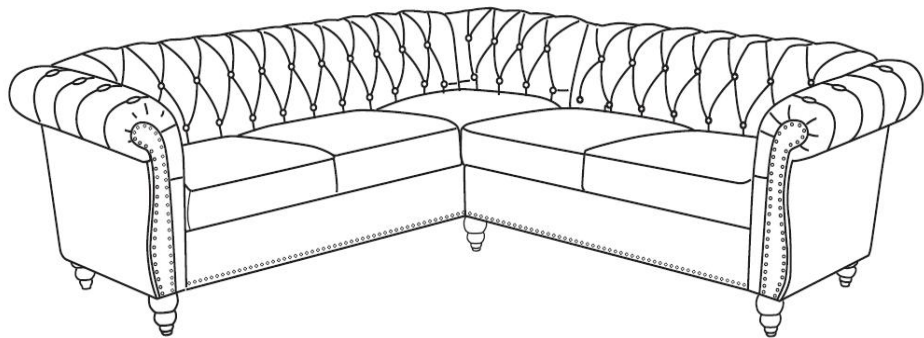

Your Three Seater Sofa +Right Arm Sofa into a Sectional sofa is ready for use.
This Sectional sofa can only be used on a flat, level surface.