

Assembly Instructions

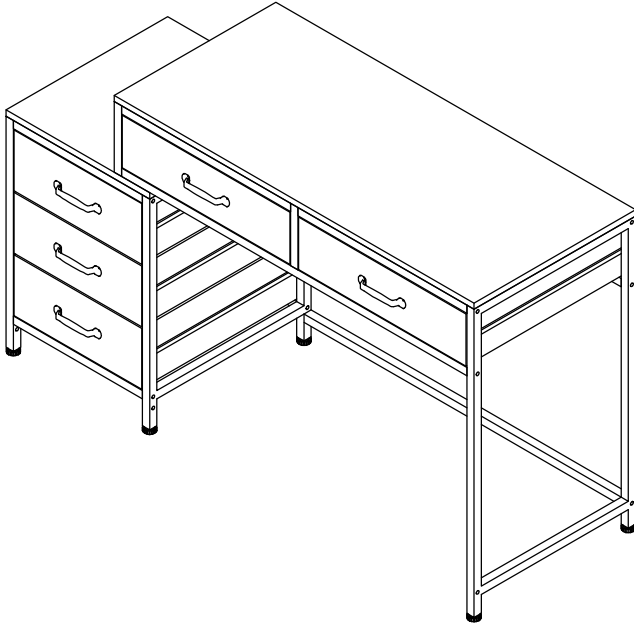
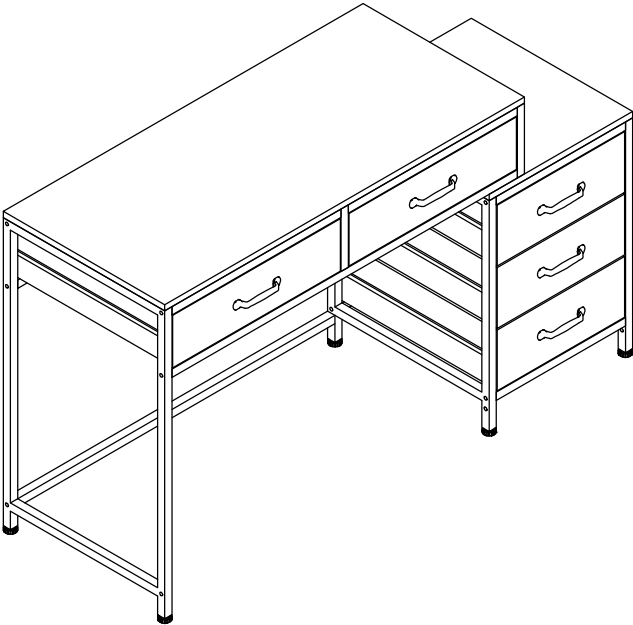

Computer table

Contact Us

We're here to help you.

Your satisfaction is our top priority. If you encounter any issues with this product, such as missing or damaged parts, we're here to help. Please retain the original packaging and take photos of the packaging and the product, then contact us as soon as possible.

Warm Tips

1. Carefully read these instructions and keep them for future reference.
2. Check the parts list and confirm everything's there before starting assembly.
3. When assembling, put all parts on a soft, smooth surface like a carpet to avoid scratches.
4. Don't fully tighten screws until all parts are confirmed in place to avoid misalignment.

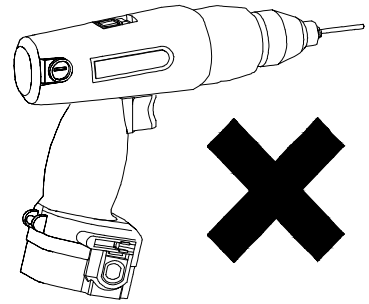
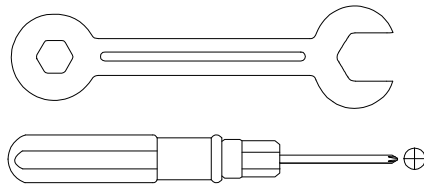
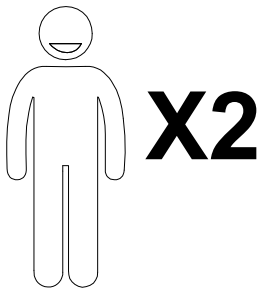

We recommend using hand tools for assembly.

If an electric screwdriver is used, reduce power and torque to avoid damage to the product.

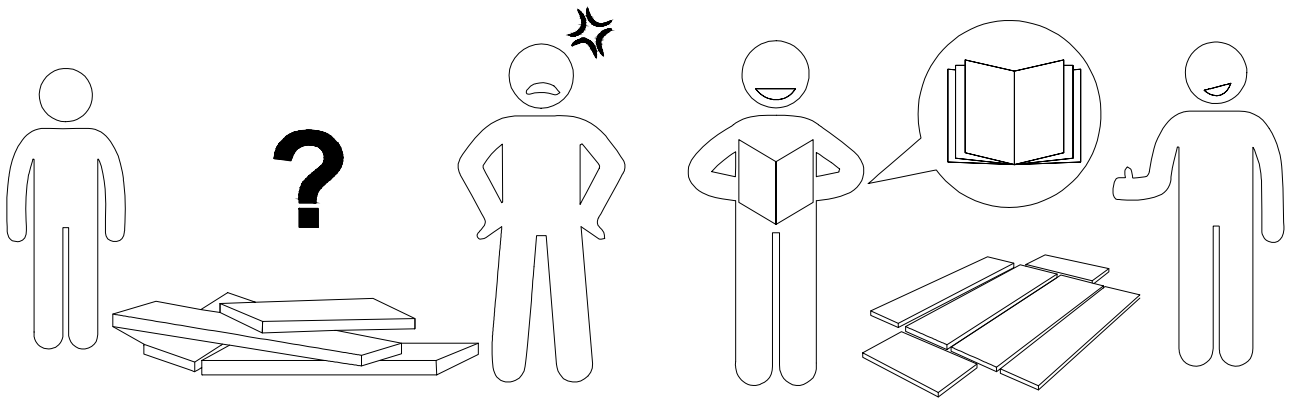

AVOID SCRATCHES

In order to avoid scratching, this furniture should be assembled on a soft surface, such as a rug.

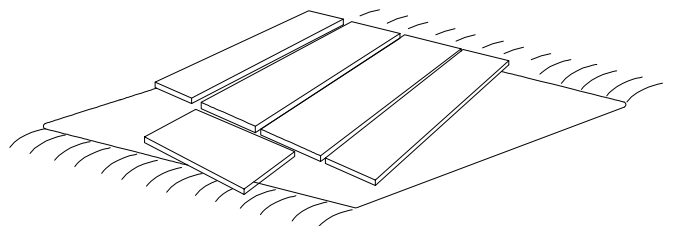
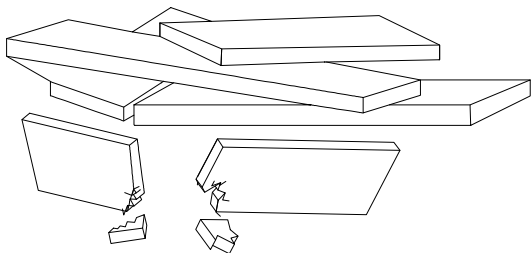

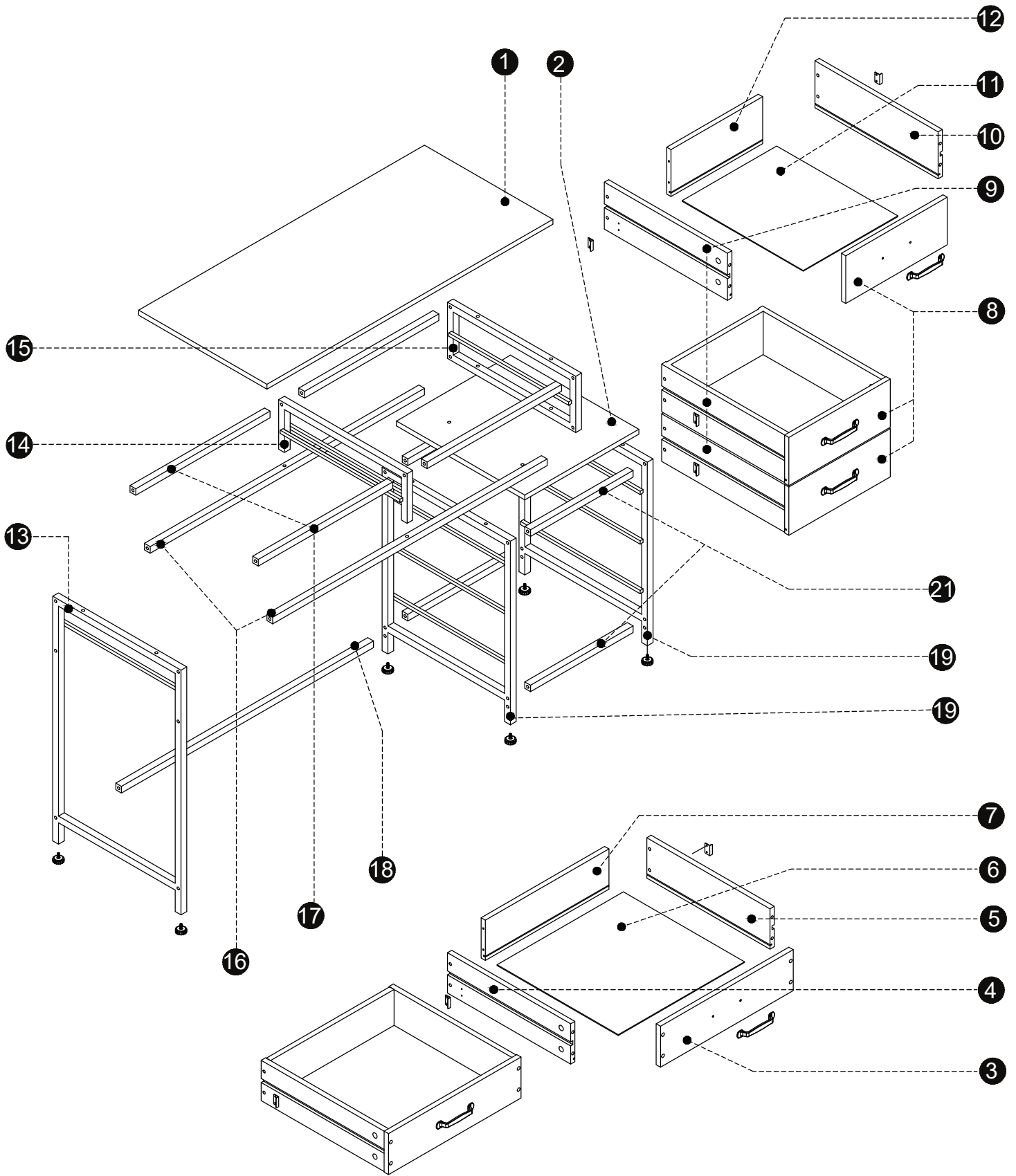







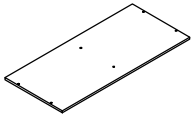
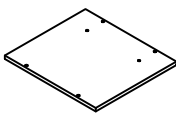
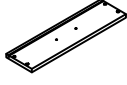
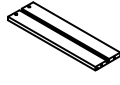
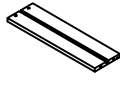
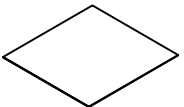

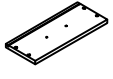

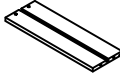
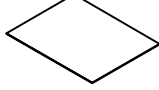

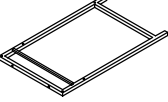
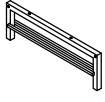
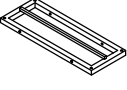
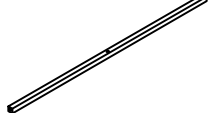

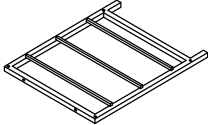





⚠ Caution

Make sure all parts are included. Most board parts are labeled or stamped on the raw edge. Contact us for a free replacement if you encounter any damaged or missing parts.

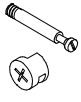
Parts List

1  1 pc	2  1 pc	3  2 pcs	4  2 pcs	5  2 pcs	6  2 pcs
7  2 pcs	8  3 pcs	9  3 pcs	10  3 pcs	11  3 pcs	12  3 pcs
13  1 pc	14  1 pc	15  1 pc	16  2 pcs	17  4 pcs	18  1 pc
19  2 pcs	21  4 pcs				

Hardware List

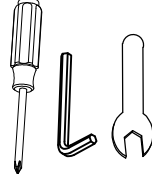
A  M6X35mm 20 pcs	B  M6X70mm 2 pcs	C  M6X30mm 10 pcs	D  M6X45mm 2 pcs	E  M6 2 pcs	F  M6X40mm 20 pcs	G  Ø7X40mm 20 pcs
H  M4X18mm 10 pcs	I  5 pcs	J  M8 6 pcs	K  Ø3.5X14mm 20 pcs	L  10 pcs		

Installation of Cams and Pins

Read each step carefully before starting. Each step of instruction should be performed in the correct order. If these steps are not followed in sequence, assembly difficulties may occur.

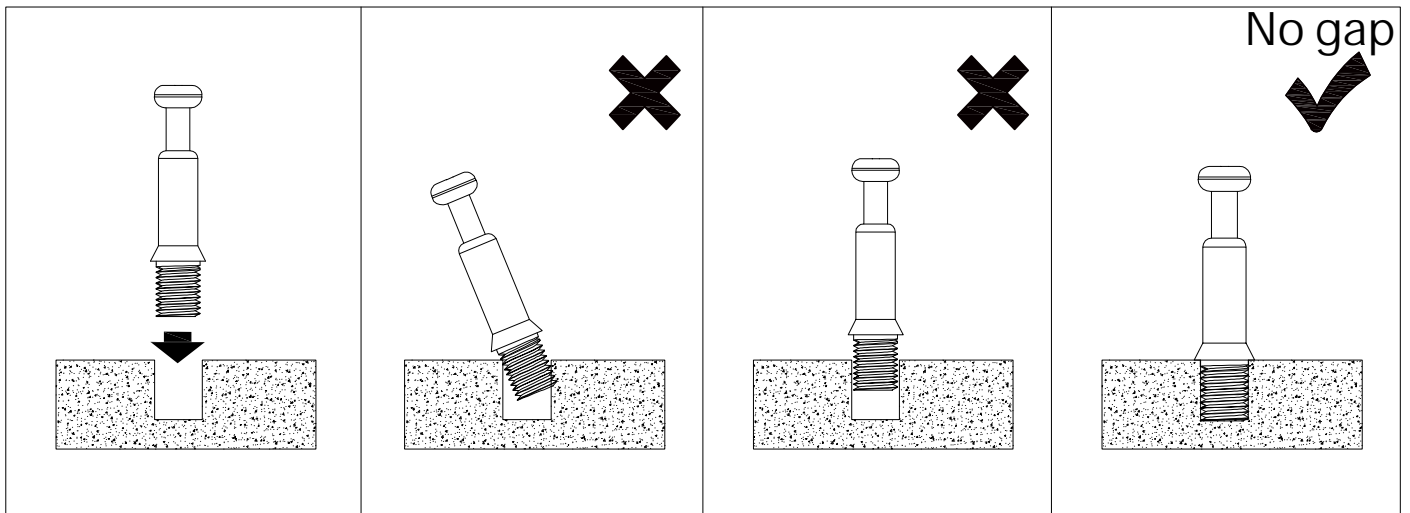
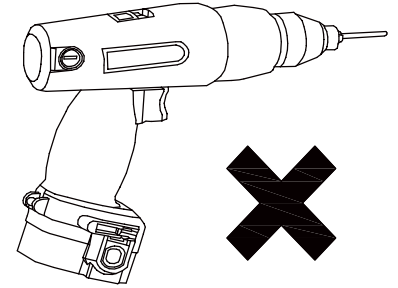

Screw the pin into the hole. Set the cams correctly by aligning the head of the cams with the lock pins. Lock the cam by turning the cam head with a screwdriver until it is tightened. Please do not use an electric screwdriver to assemble the unit.

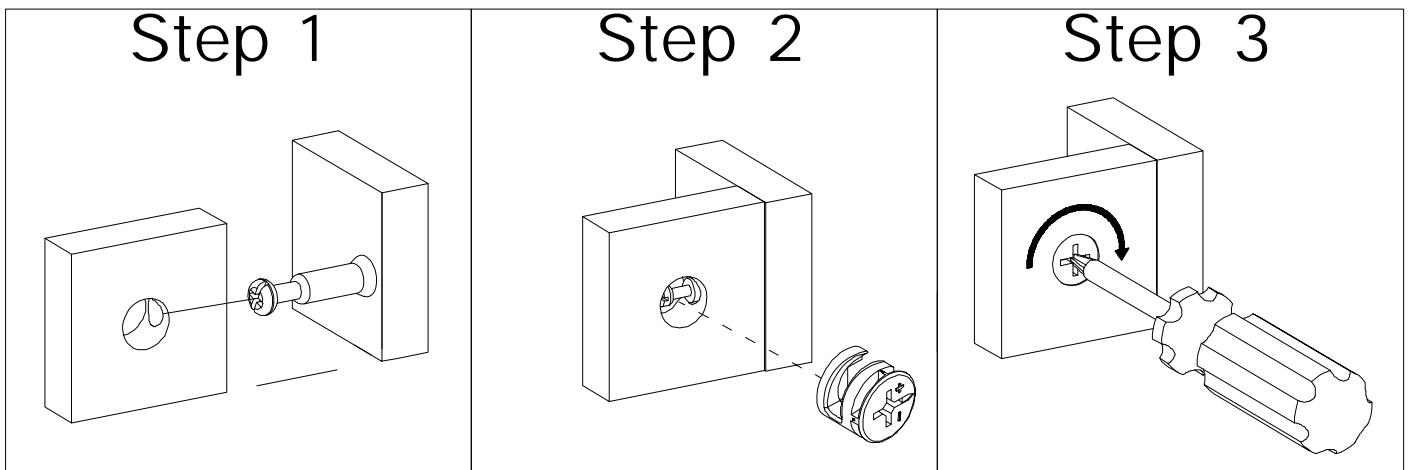

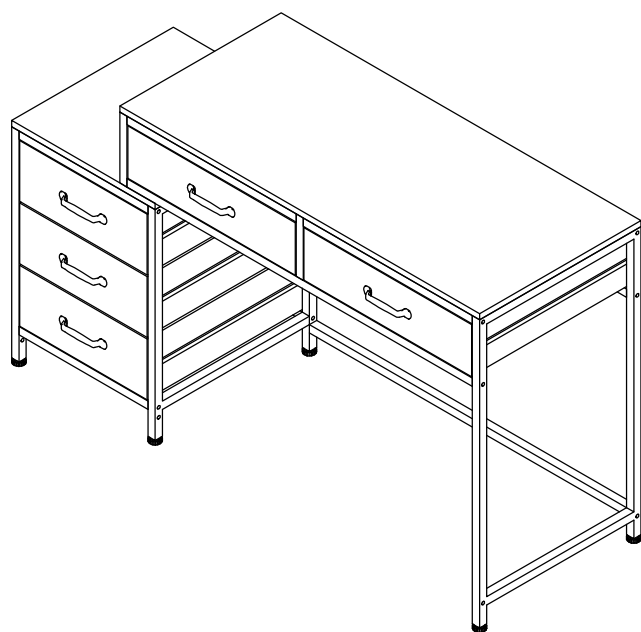
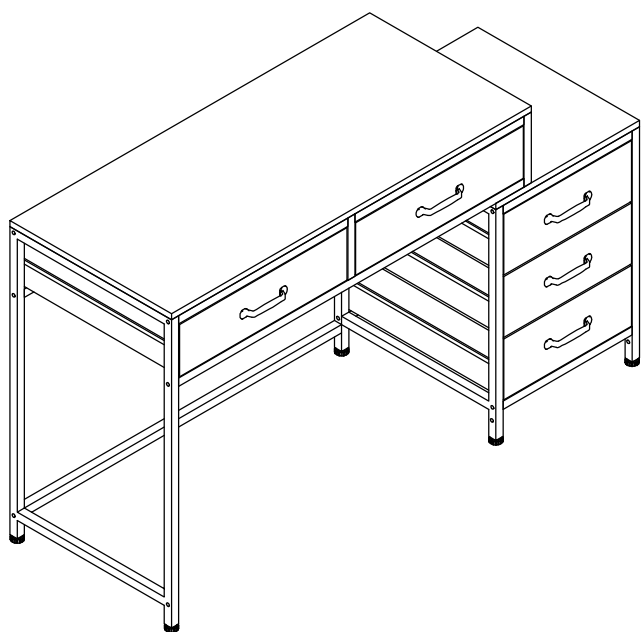

left

right



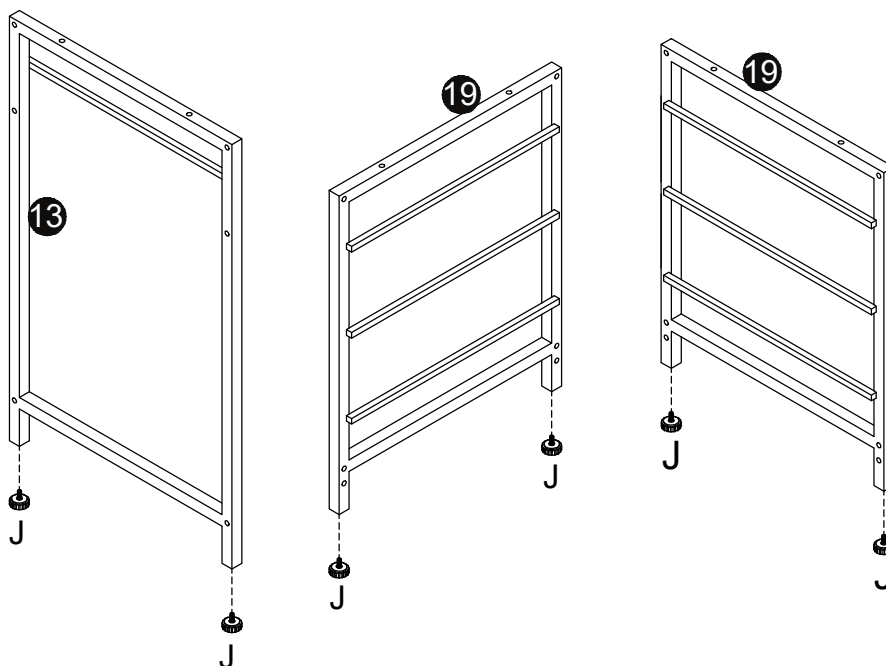

1

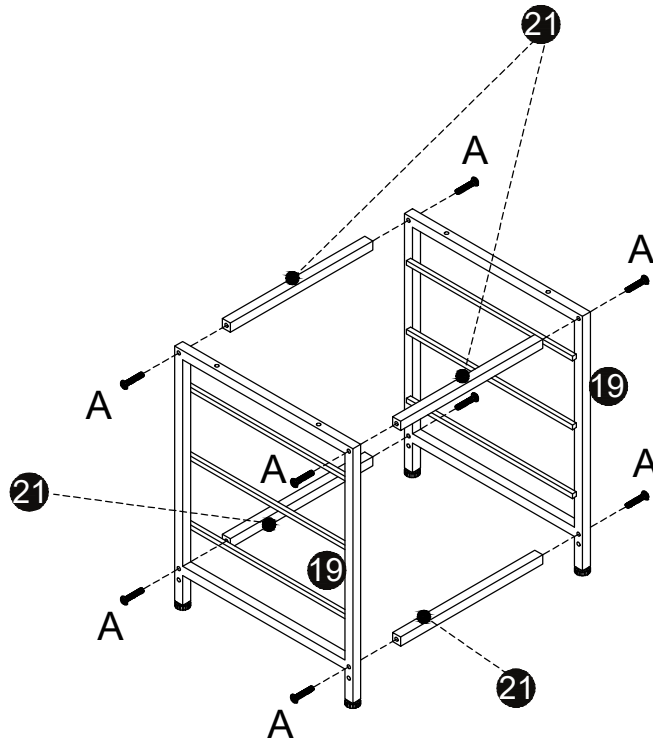

J

M8
6 pcs

2



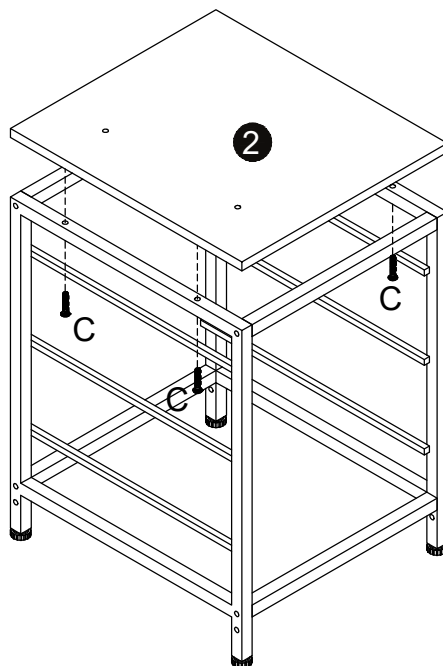

A

M6x35mm
8 pcs

3



C

M6x30mm
4 pcs

4

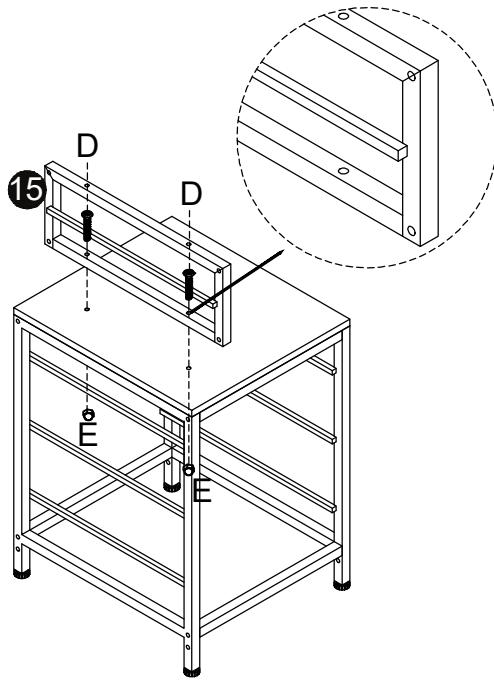
E	D
	
M6	M6x45mm
2 pcs	2 pcs



Notes: Install NO.15 tube frame following the arrow direction as the instruction picture shows.

5

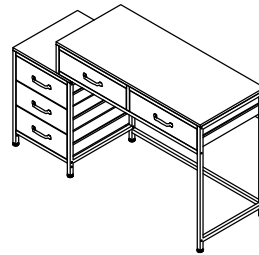
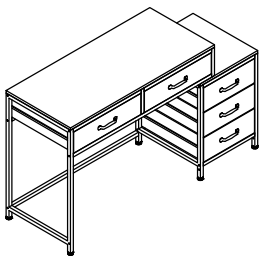

A

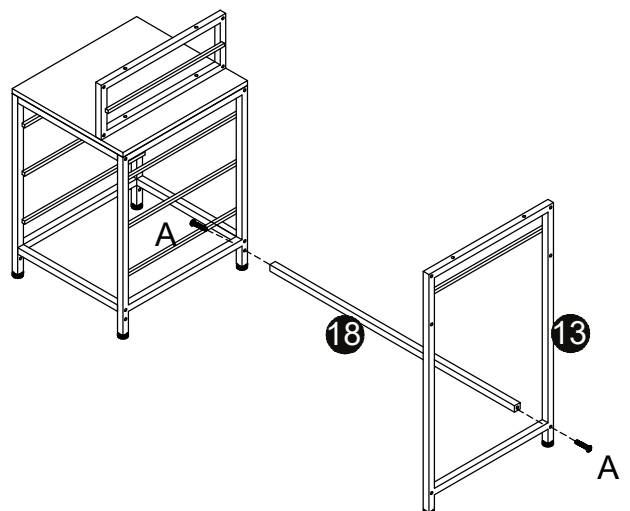
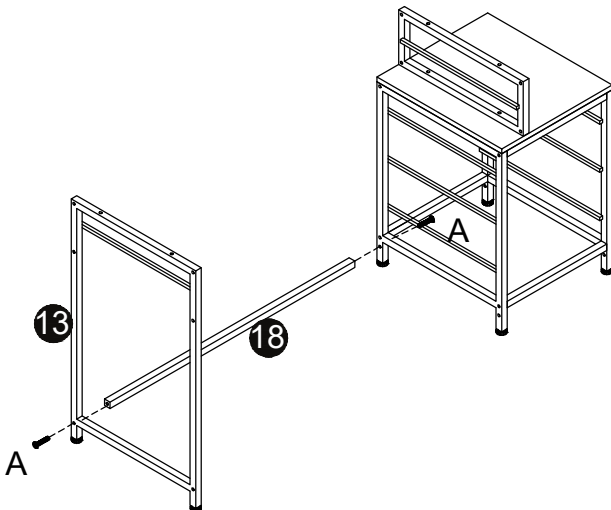
M6x35mm
2 pcs



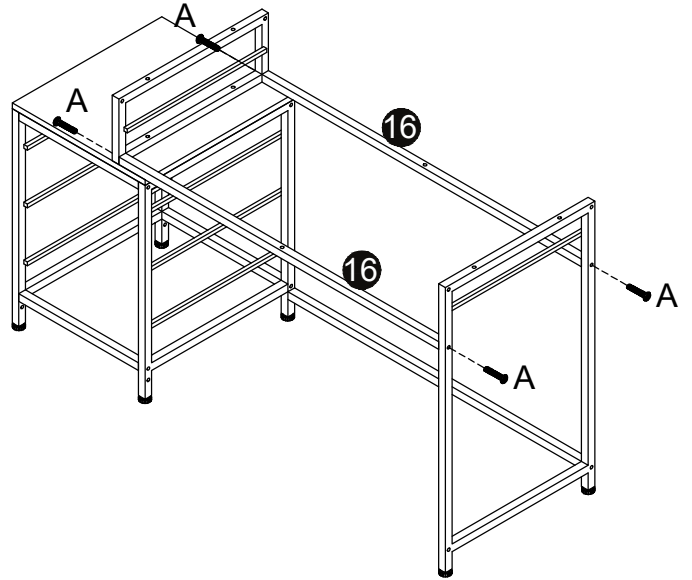
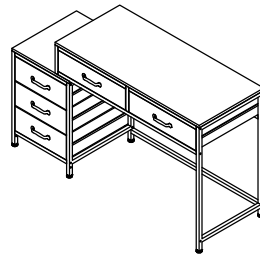
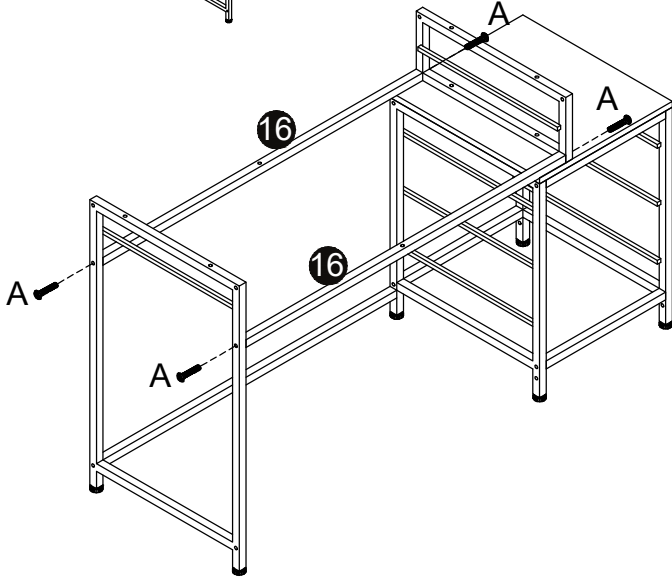
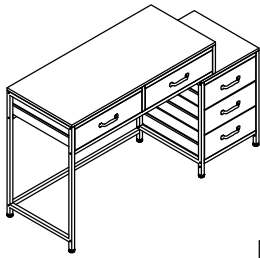

6

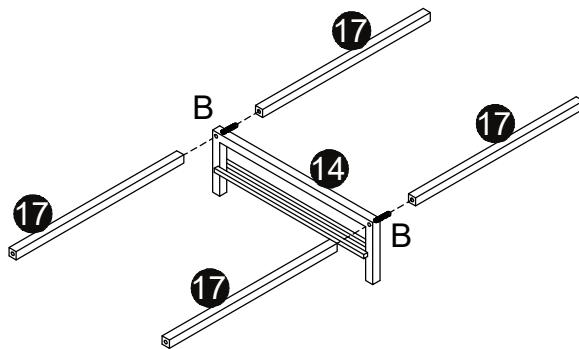

A

M6x35mm
4 pcs

7

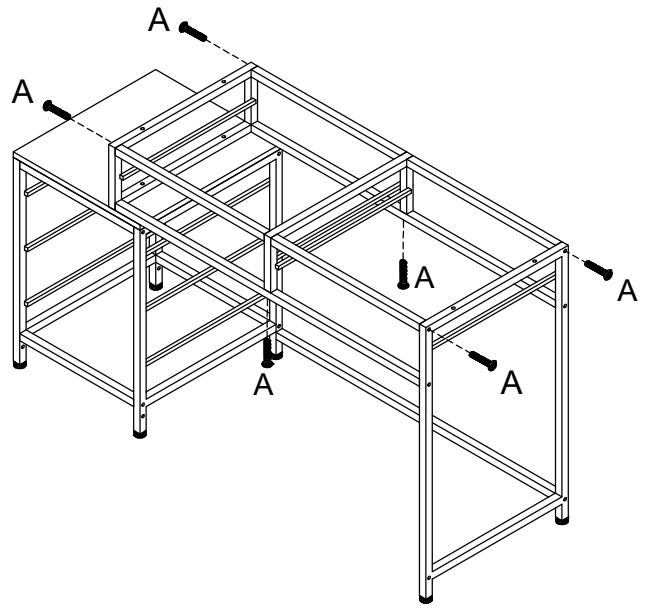
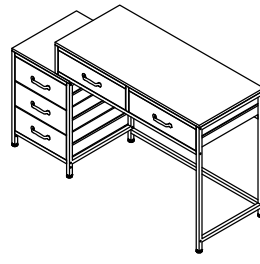
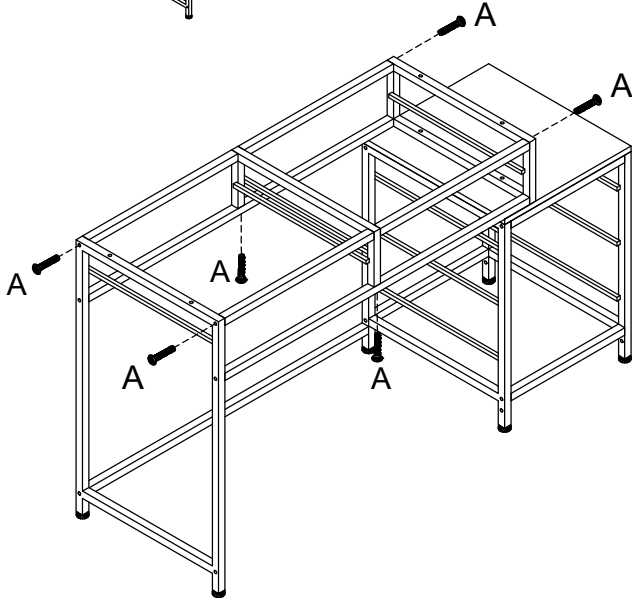
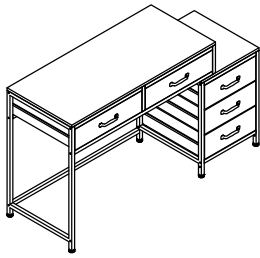

B

M6x70mm
2 pcs

8

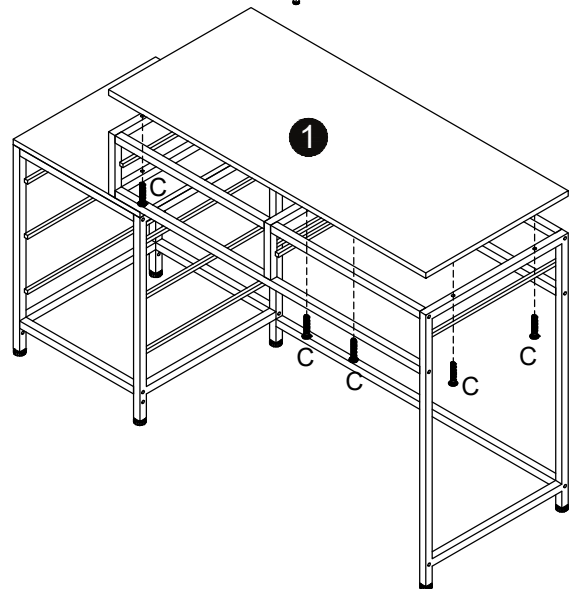
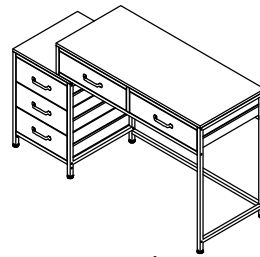
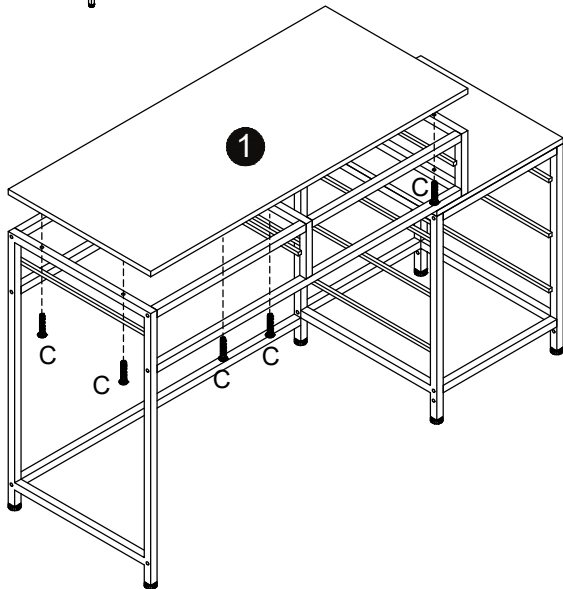
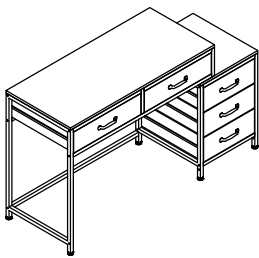

A

M6x35mm
6 pcs

9



C

M6x30mm
6 pcs

10

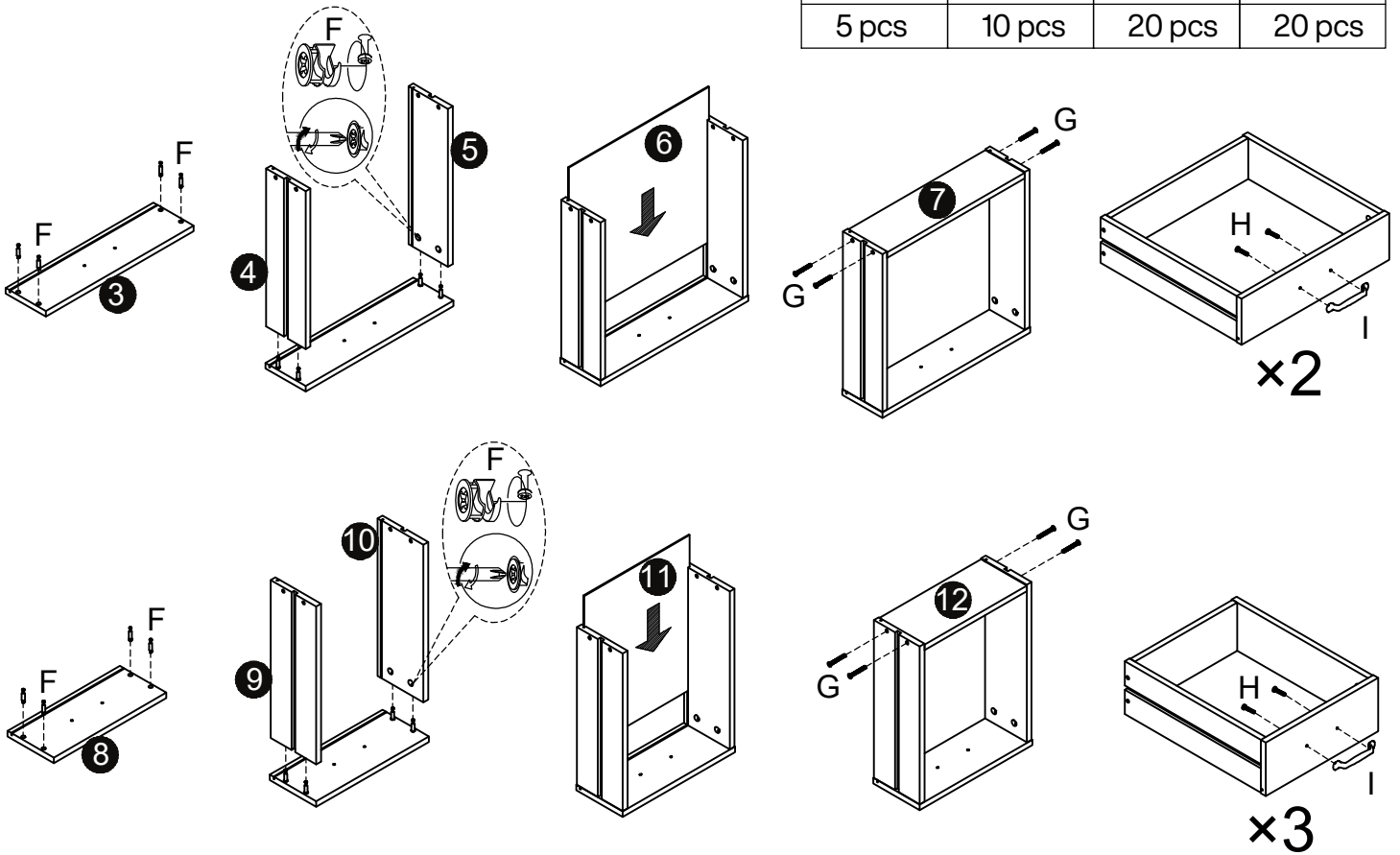
I	H	G	F
5 pcs	M4x18mm	Ø7x40mm	M6x40mm
	10 pcs	20 pcs	20 pcs

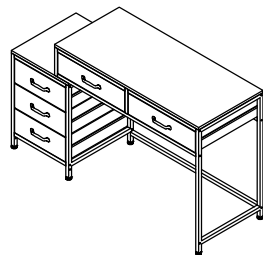

11



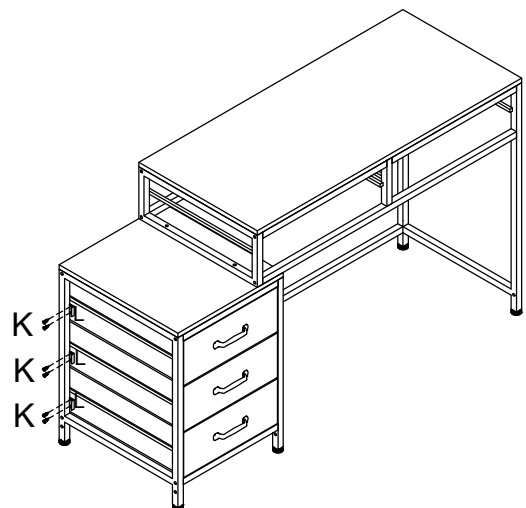
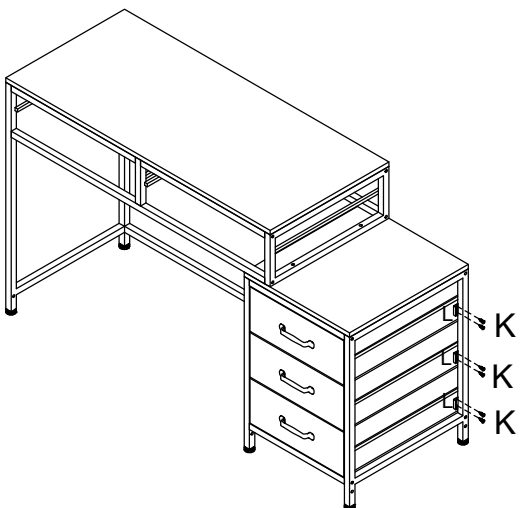

K	L
Ø3.5x14mm	
12 pcs	6 pcs

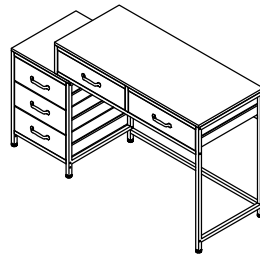
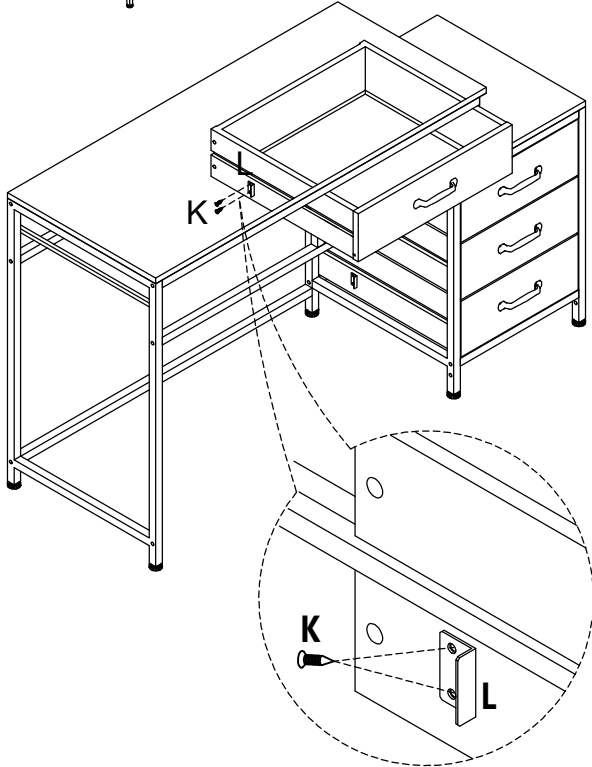
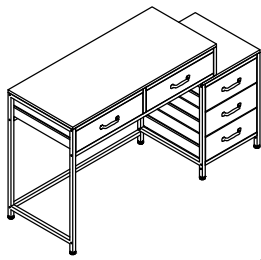

12



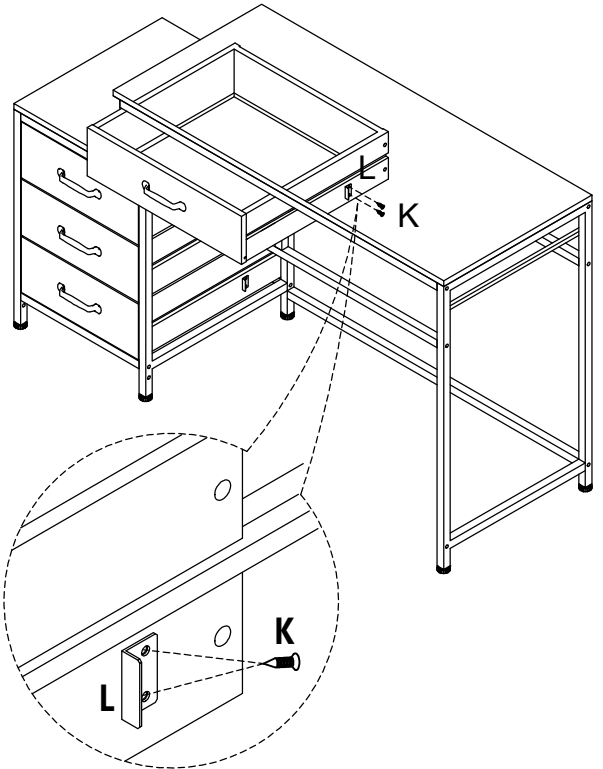

K	L
	
Ø3.5x14mm	
4 pcs	2 pcs

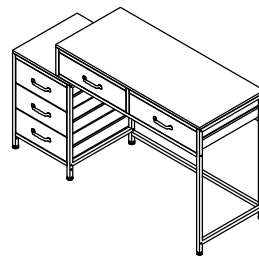
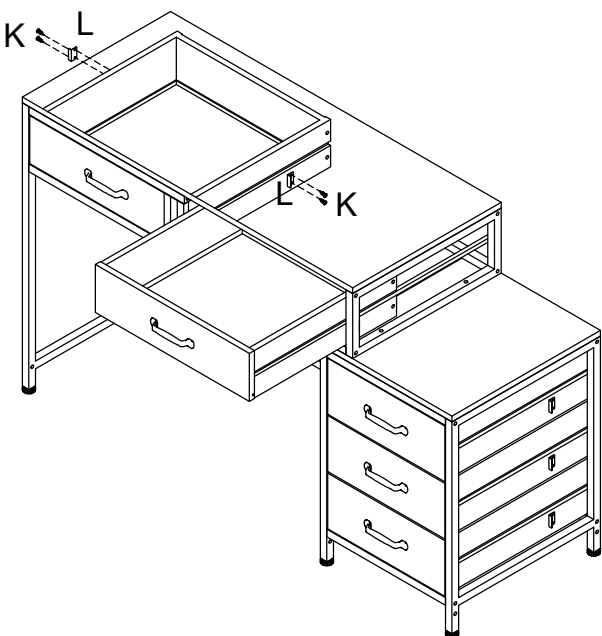
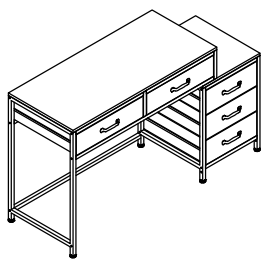

13



K	L
	
Ø3.5x14mm	
4 pcs	2 pcs

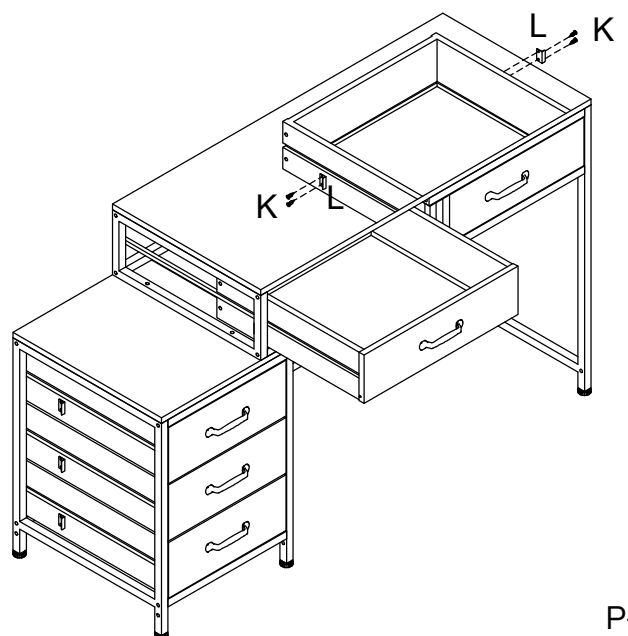

Thank you for your support!

