

# 5 Tier Bookcase

Product ID. QCMVH

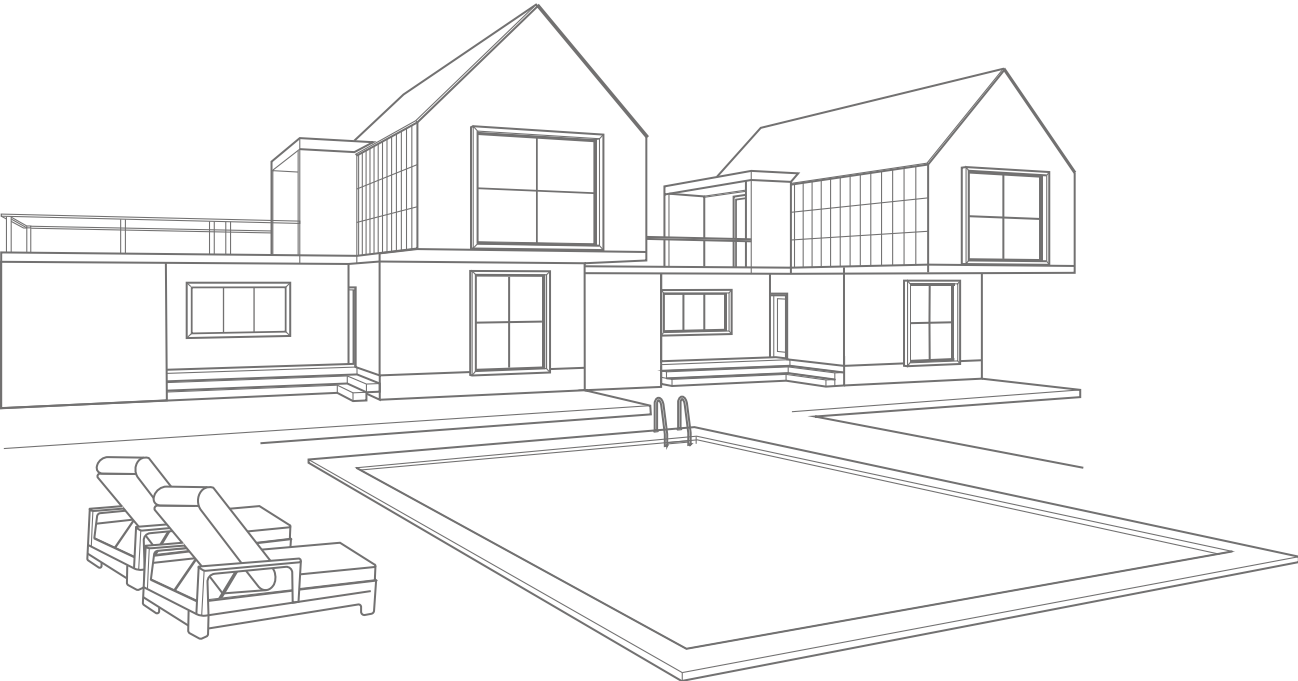





Scan for Support  
[support@garvee.com](mailto:support@garvee.com)

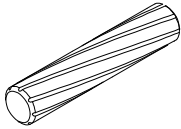

Distributed by  
**GARVEE**.com

**HARDWARE LIST**

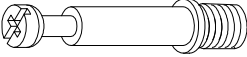
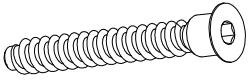
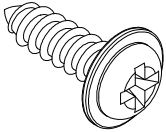
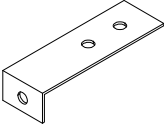
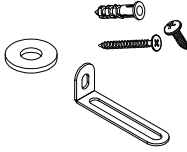
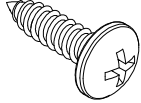
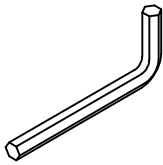
Please check that you have all the parts listed below

<b>A x 42+2PCS</b>  <b>Ø6*30mm</b>	<b>B x 58+2PCS</b>  <b>Ø15*9mm</b>	<b>Cx 58+2PCS</b>  <b>Ø6*35mm</b>	<b>D x 4+1PC</b>  <b>Ø7*38mm</b>
<b>E x 48+2PCS</b>  <b>Ø8*Ø3.5*12mm</b>	<b>F x 8PCS</b>  <b>Ø8*Ø4*10mm</b>	<b>G x 2PCS</b>  <b>Ø8*Ø4*10mm</b>	<b>H x 24+2PCS</b>  <b>Ø8*Ø4*10mm</b>
<b>J x 1PC</b>  <b>M4</b>	<b>K x 1PC</b> 		

**1**

Ø6x35mm

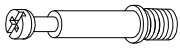

C x 15

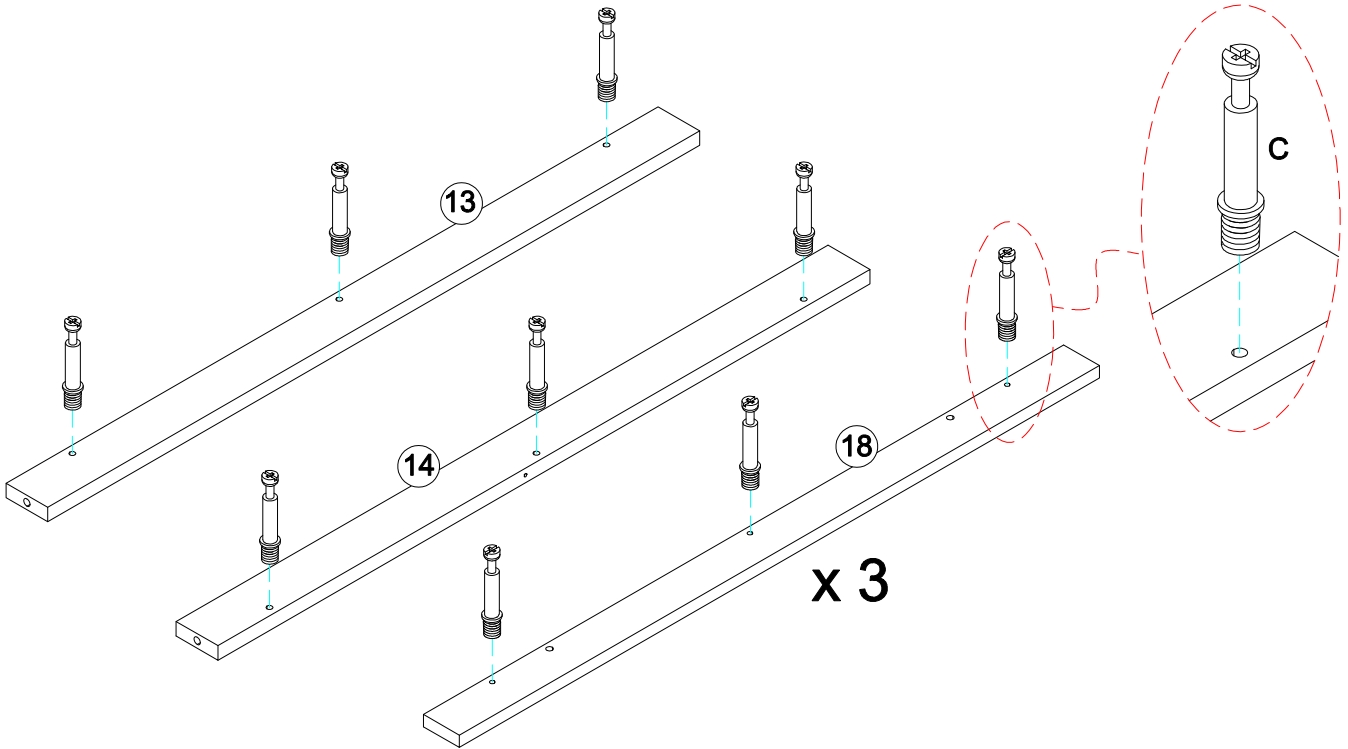

**2**

Ø6x30mm



A x 8

Ø6x35mm

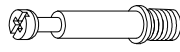

C x 4

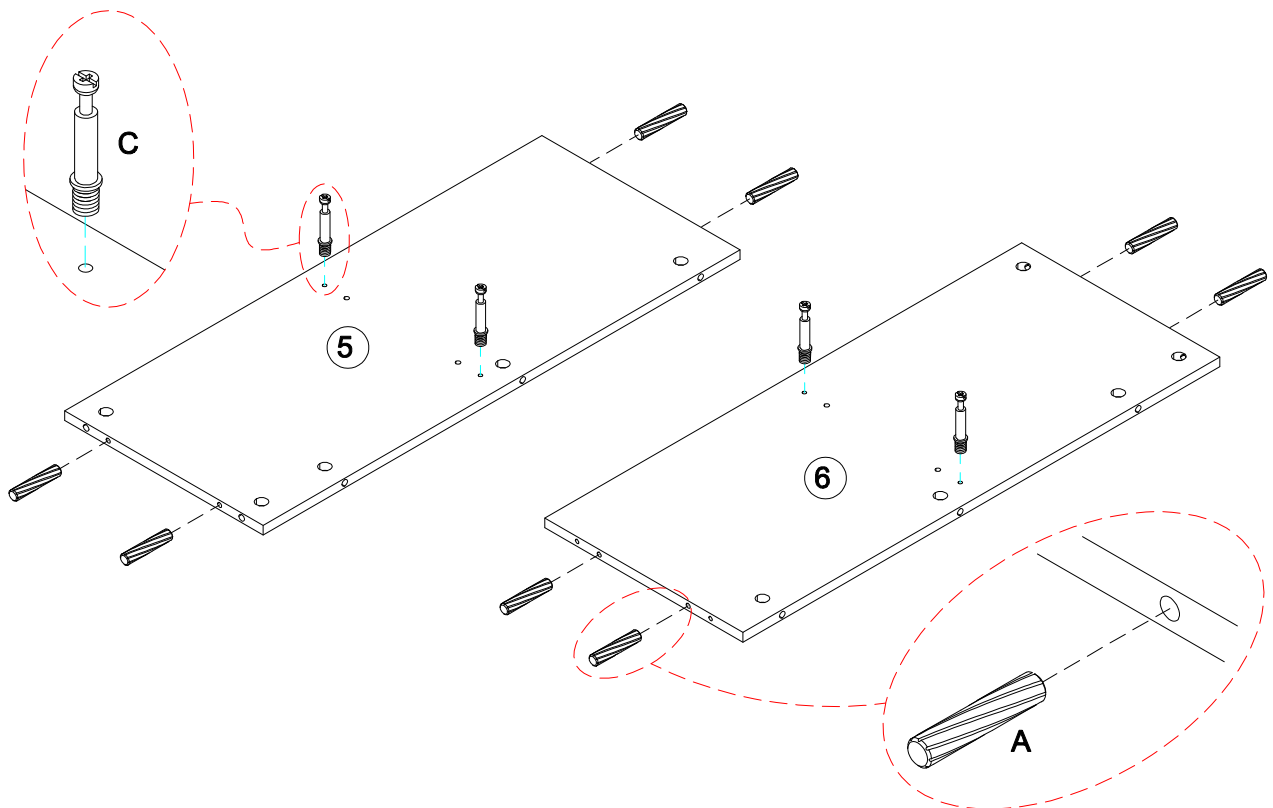

**3**

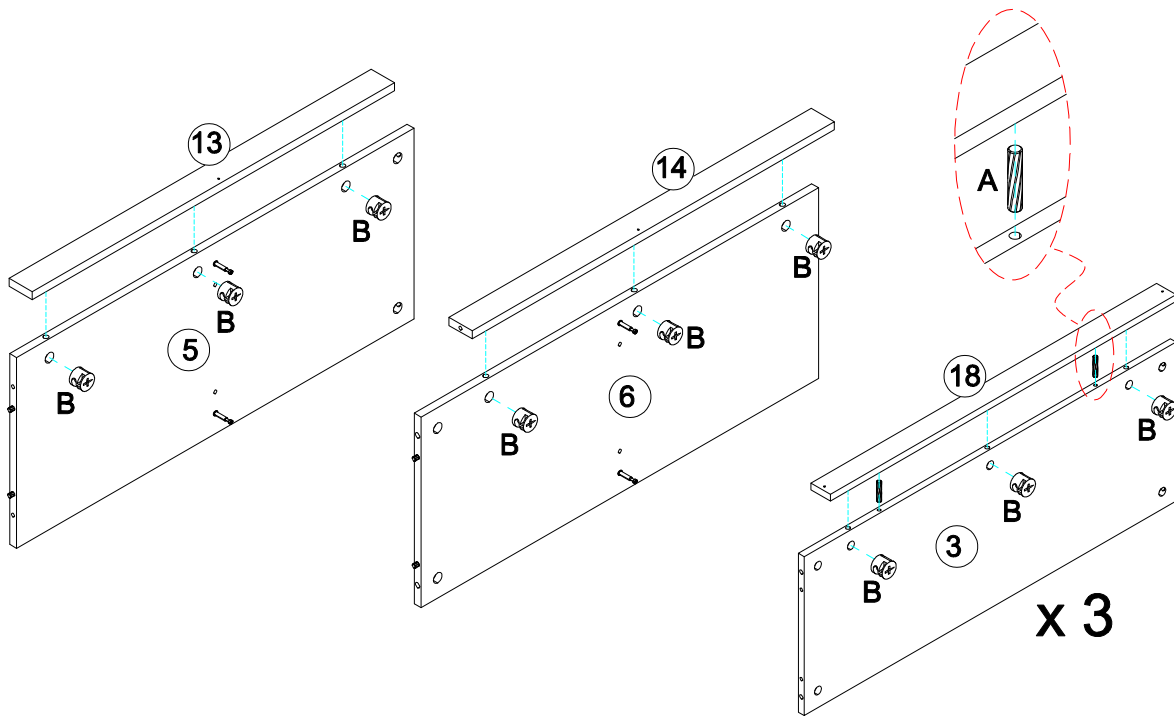

**4**

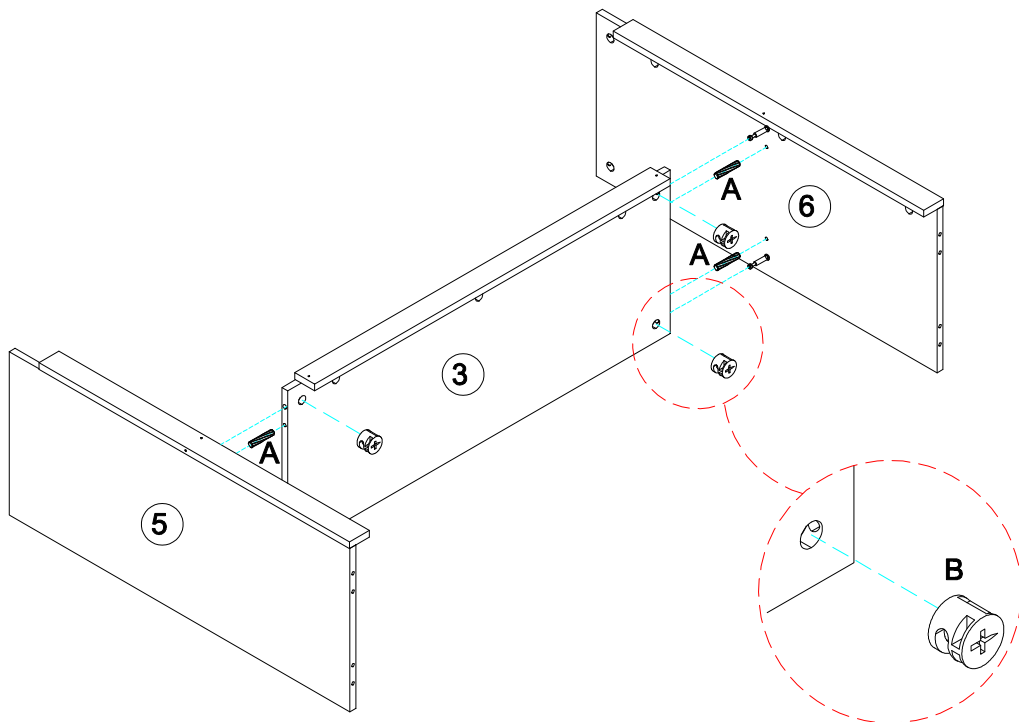

**5**

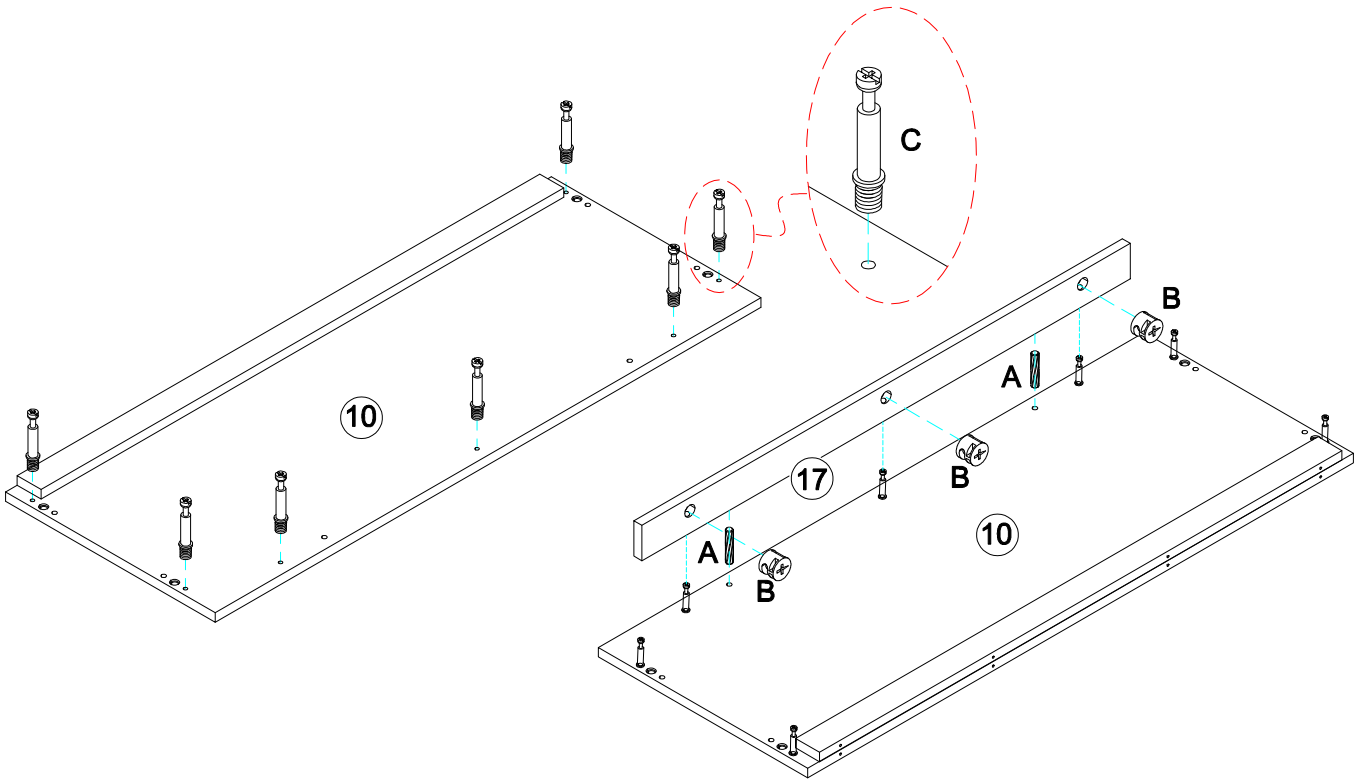
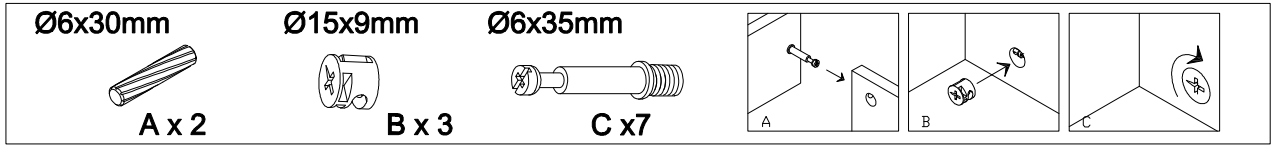

**6**

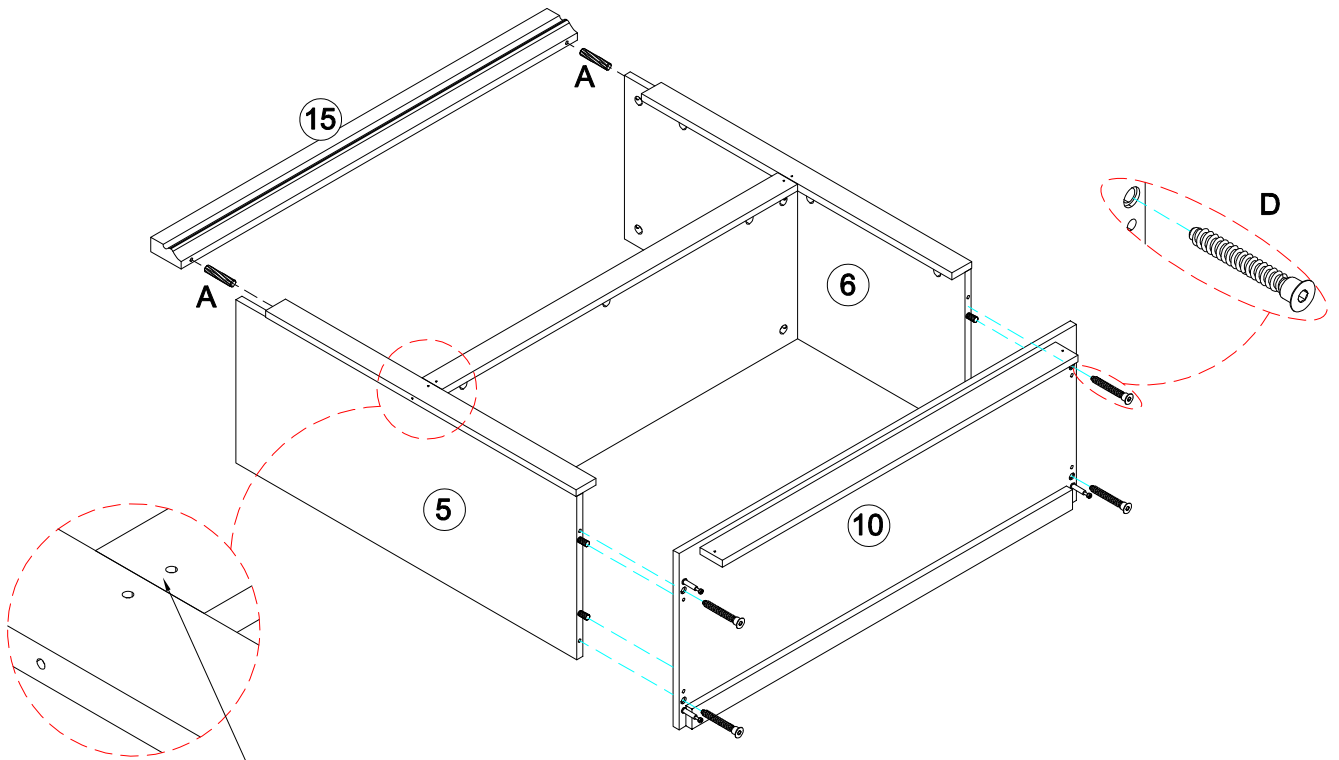
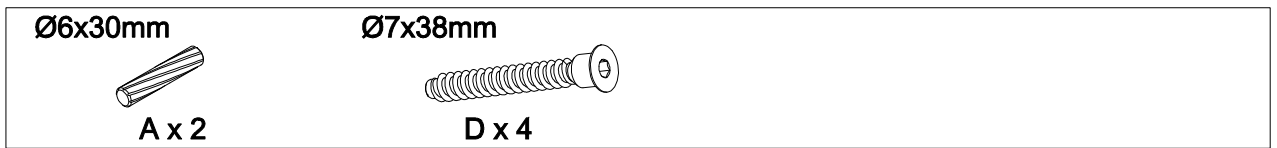

Noted the holes is alignment

7

Ø6x35mm

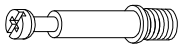

C x7

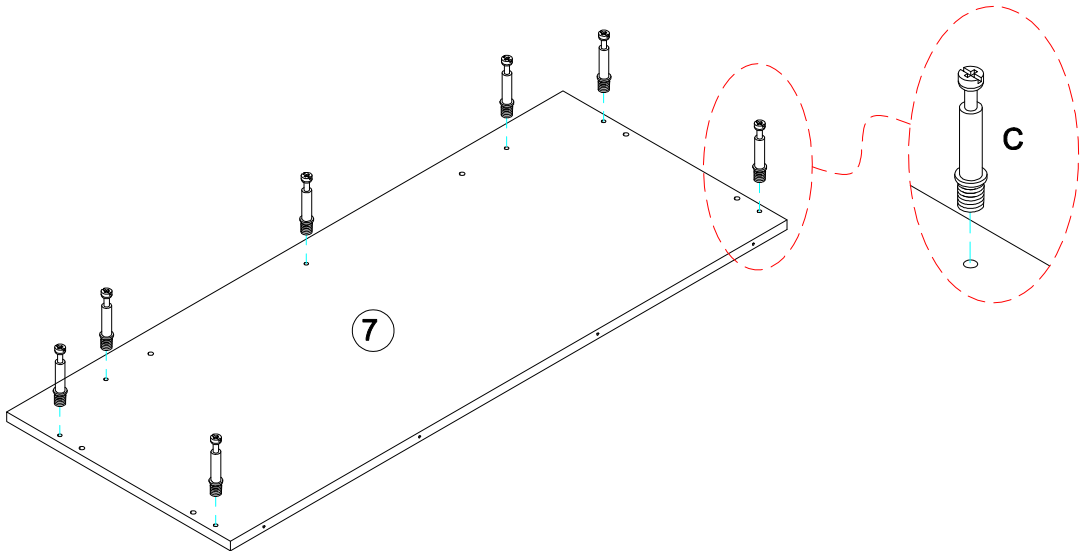

8

Ø6x30mm



A x2

Ø15x9mm



B x7

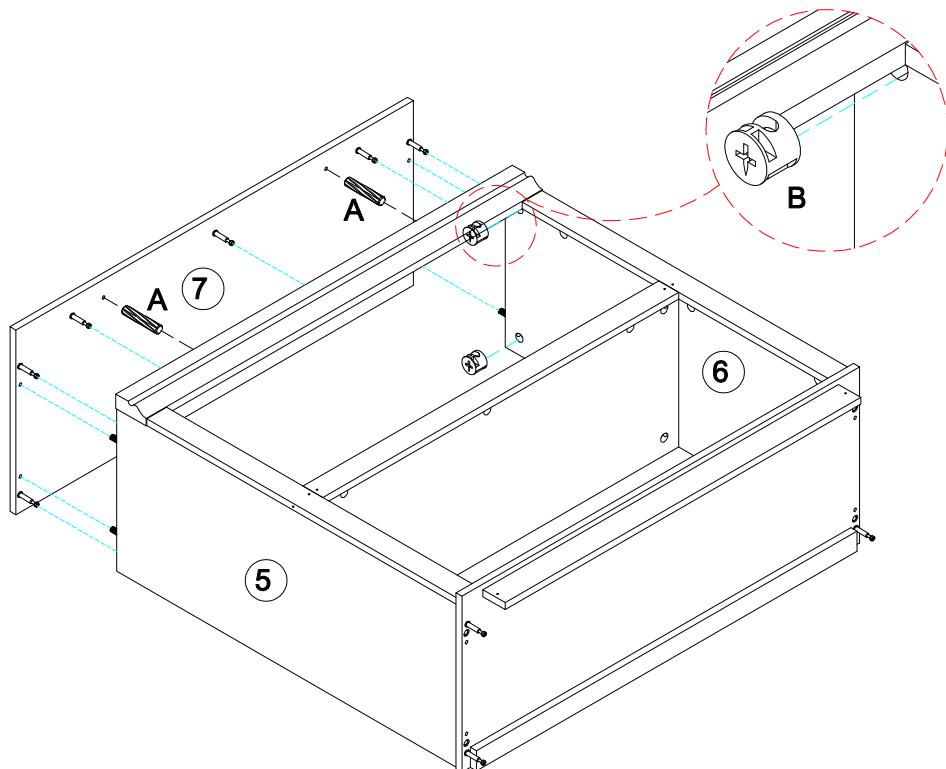
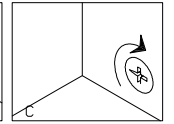
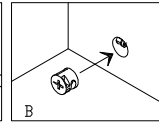
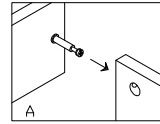

9

Ø6x35mm

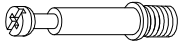

C x 8

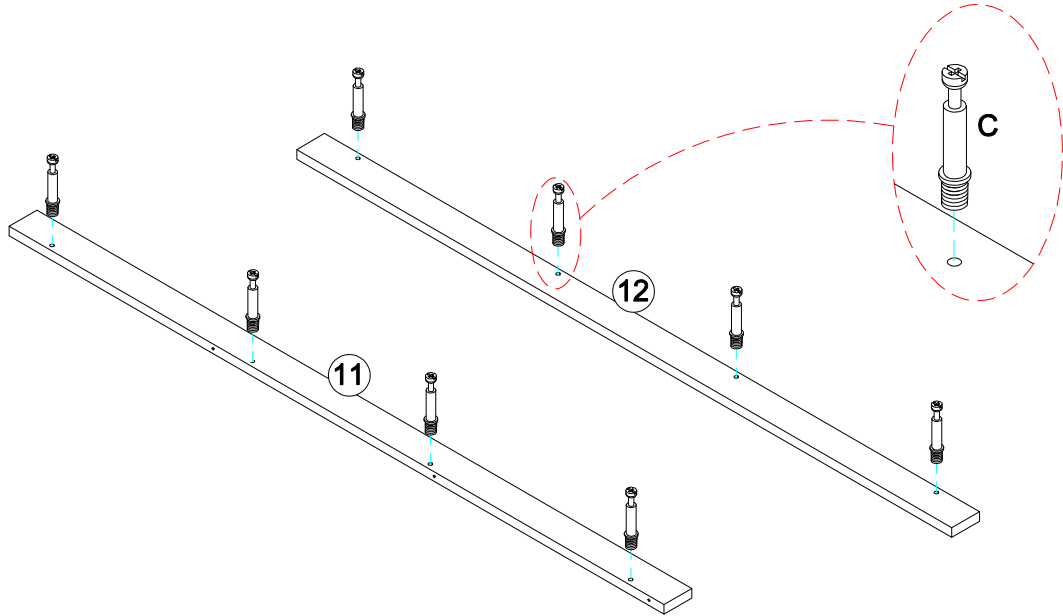

10

Ø6x30mm



A x 4

Ø6x35mm

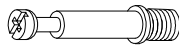

C x 12

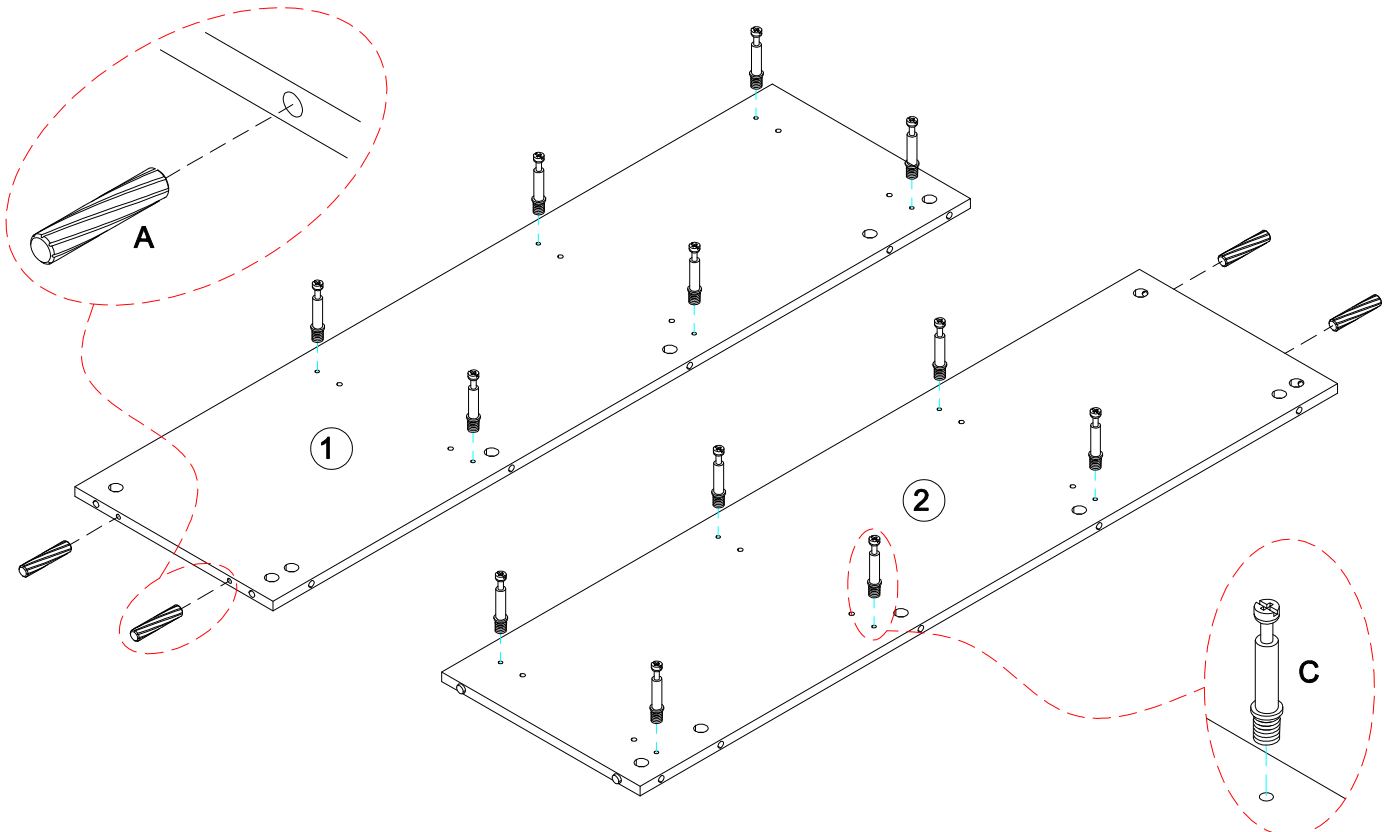

11

Ø15x9mm



B x 8

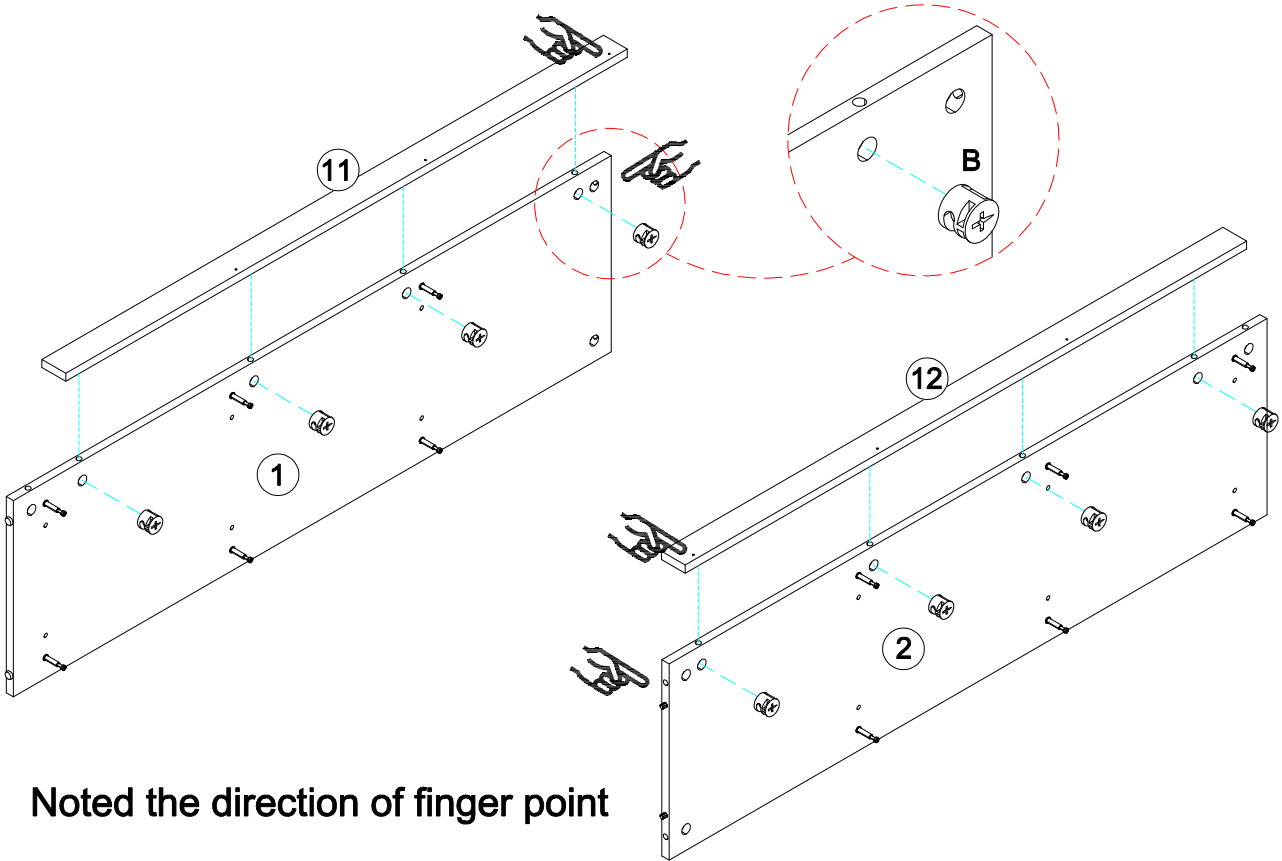
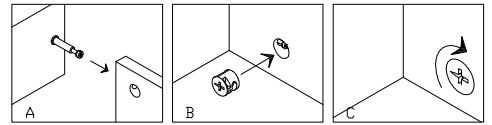

Noted the direction of finger point

12

Ø6x35mm

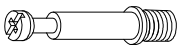

C x 5

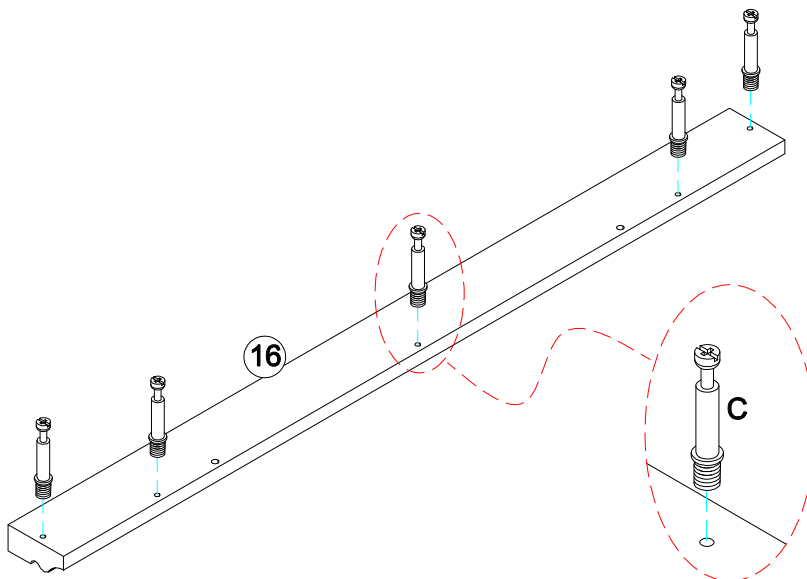

**13**

Ø6x30mm



A x 12

Ø15x9mm



B x 12

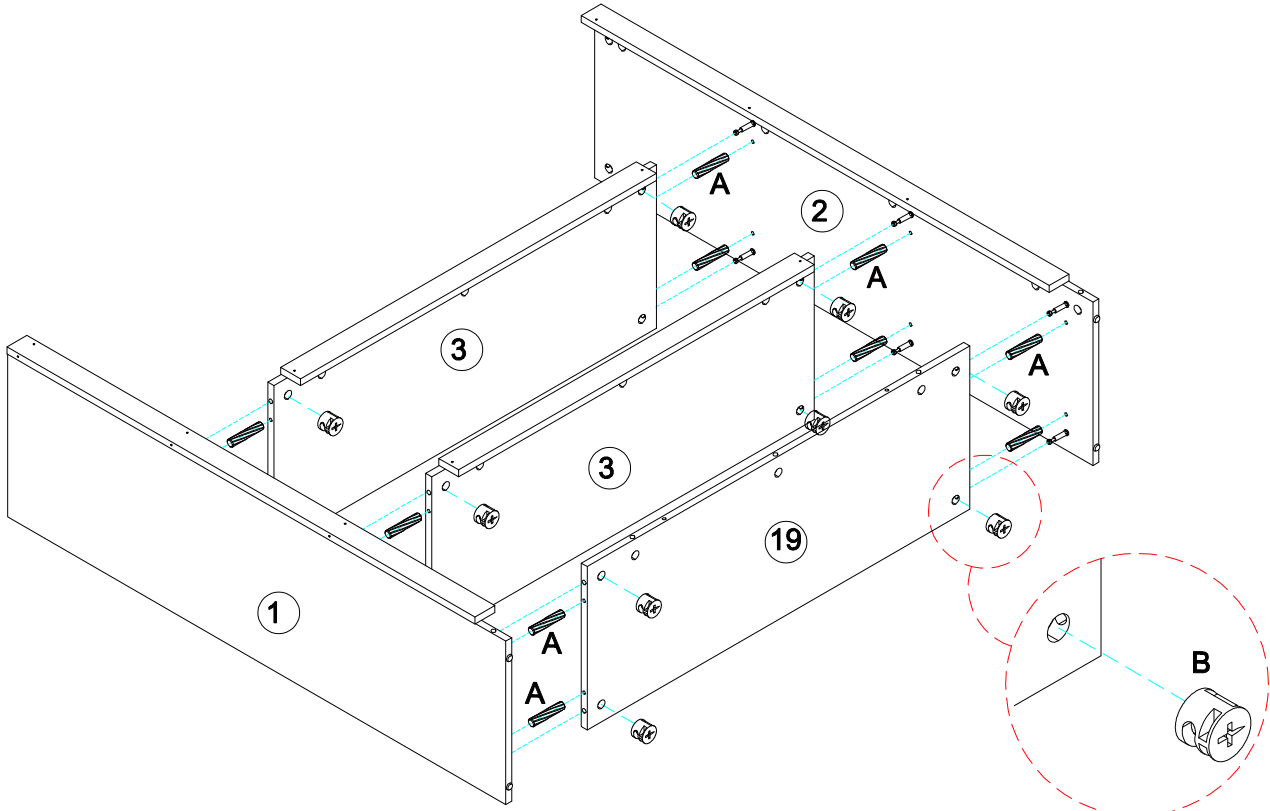
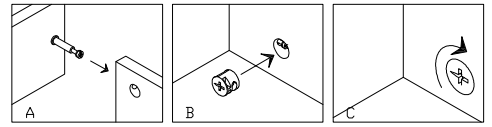

**14**

Ø6x30mm



A x 2

Ø15x9mm



B x 5

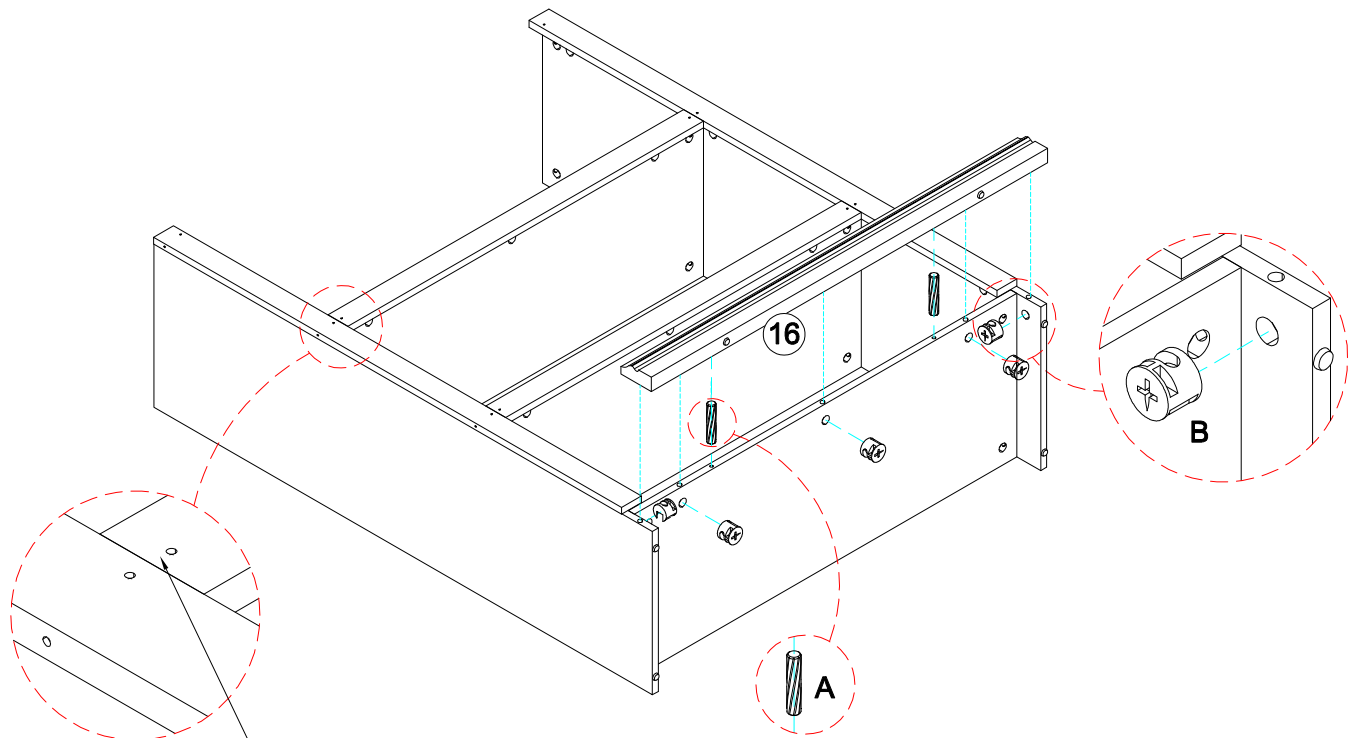
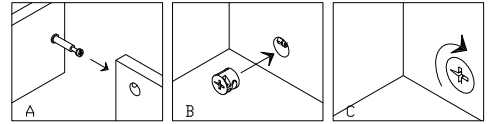

Noted the holes is alignment

15

Ø15x9mm



B x 4

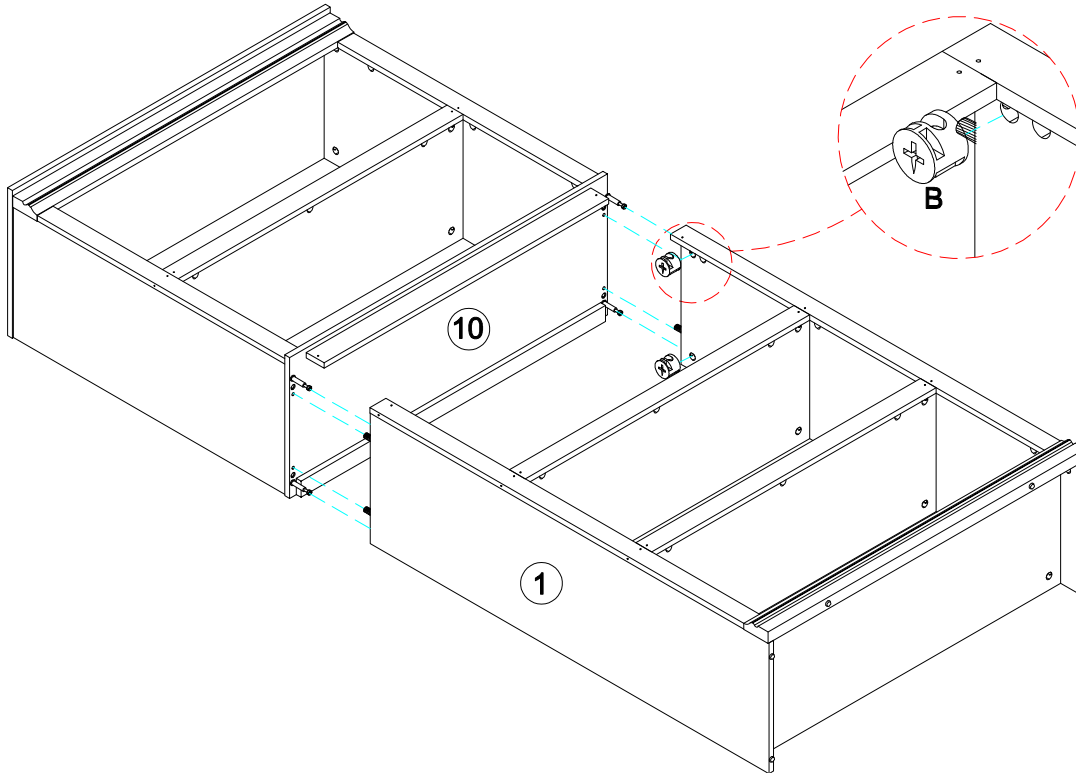
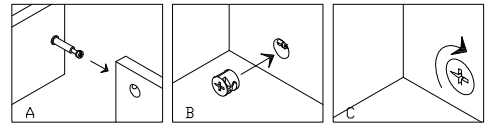

16

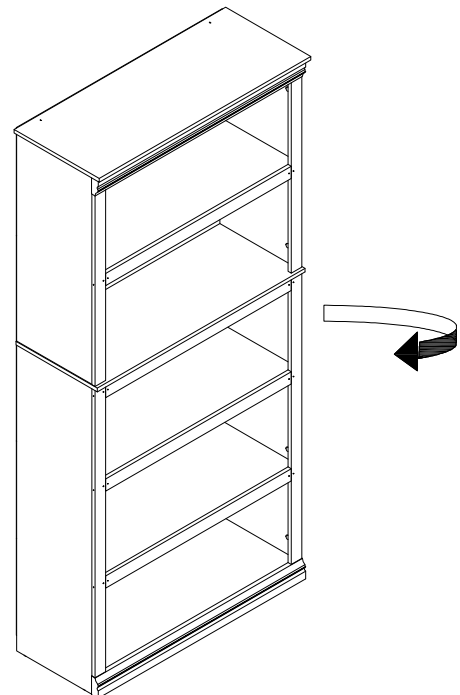
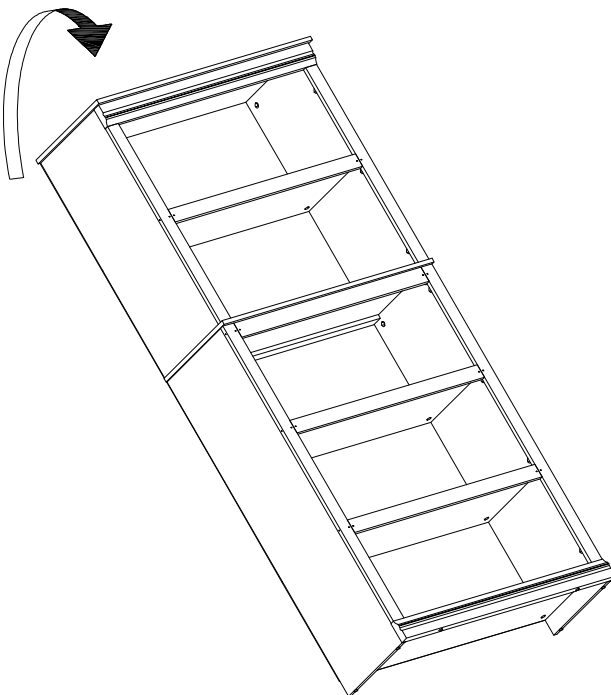

17

Ø3.5\*12mm



E x 48

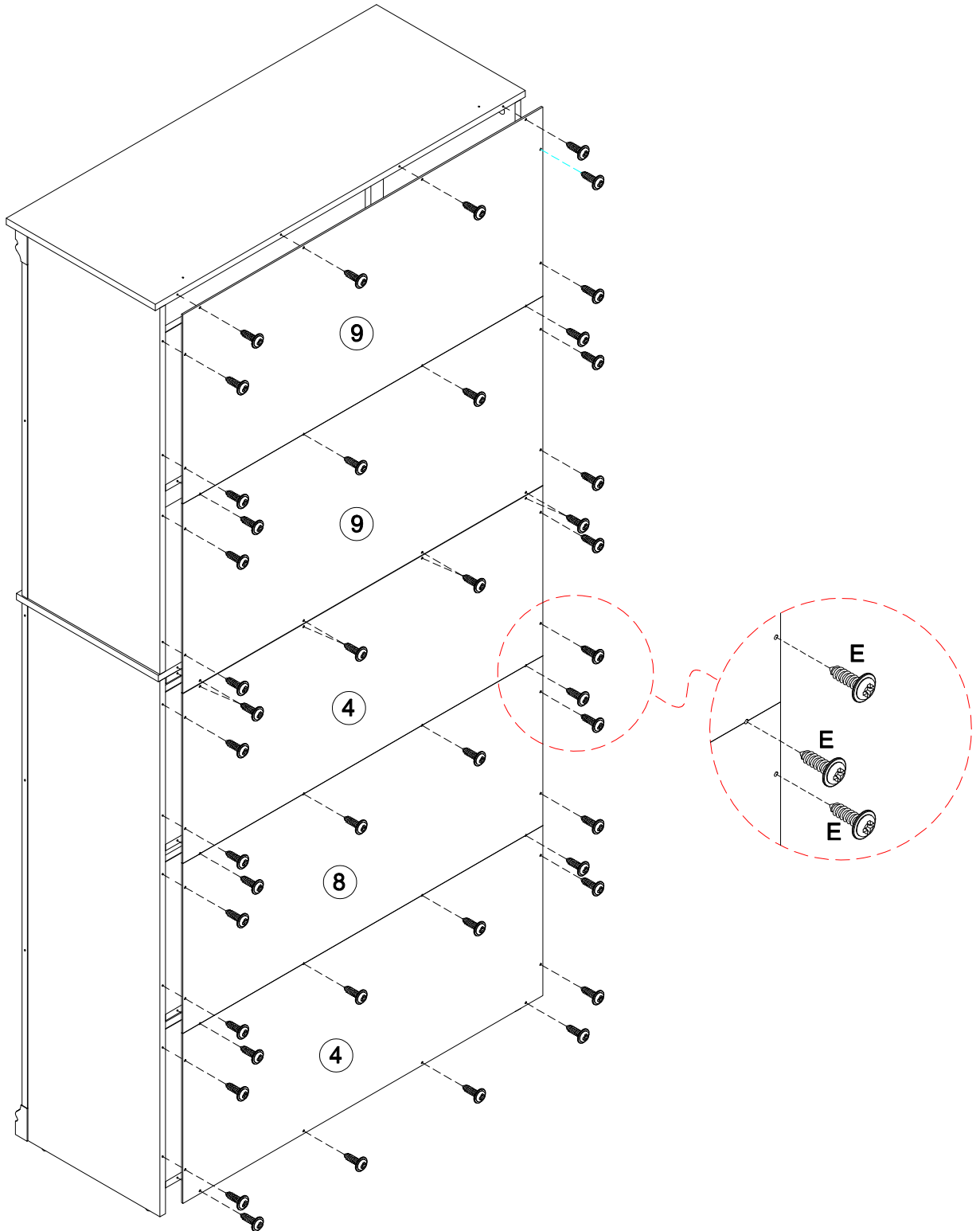

18

Ø4\*10mm



H x 24

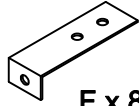

F x 8

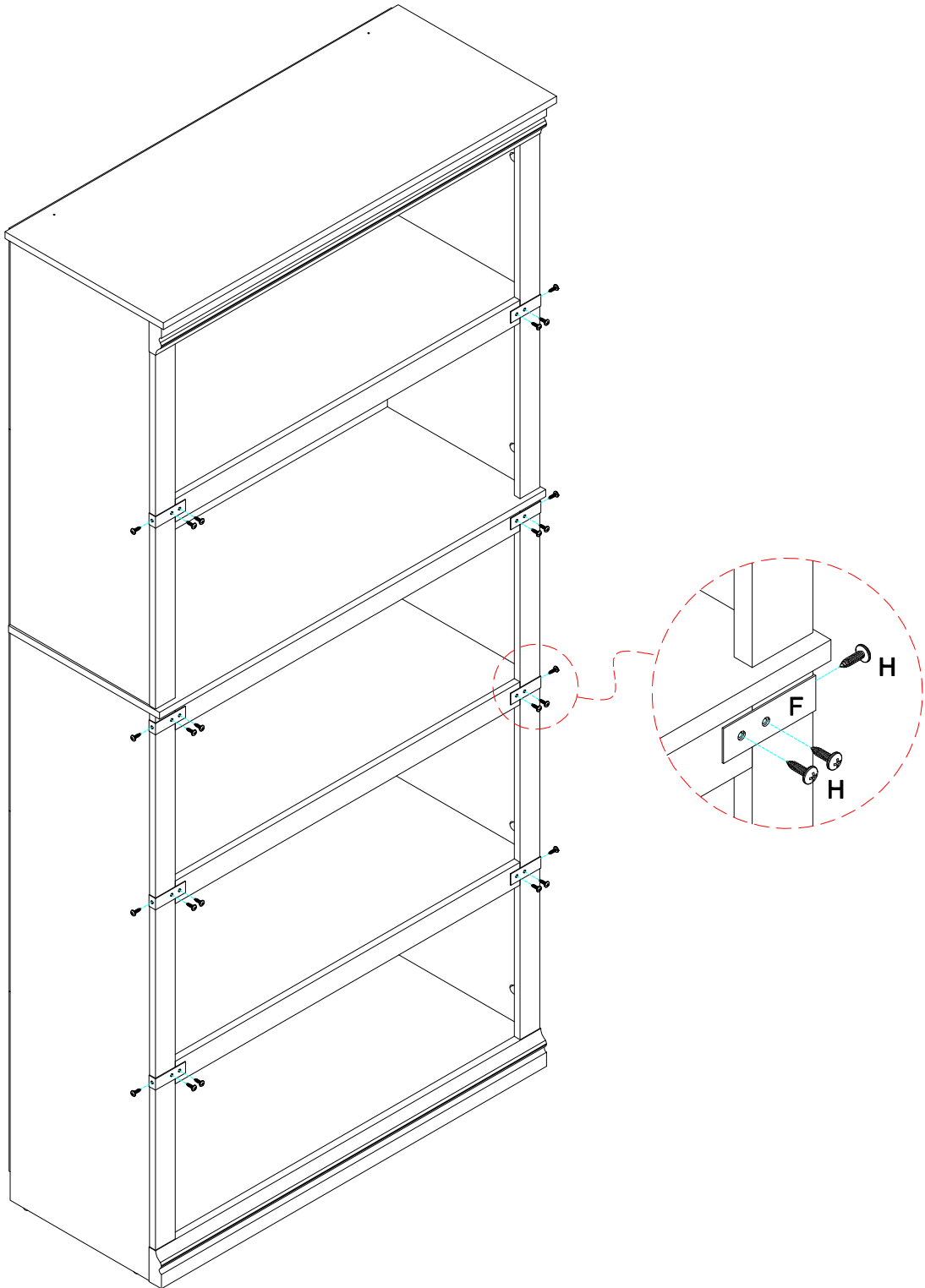

19

G x 2

