

## Assembly Instructions

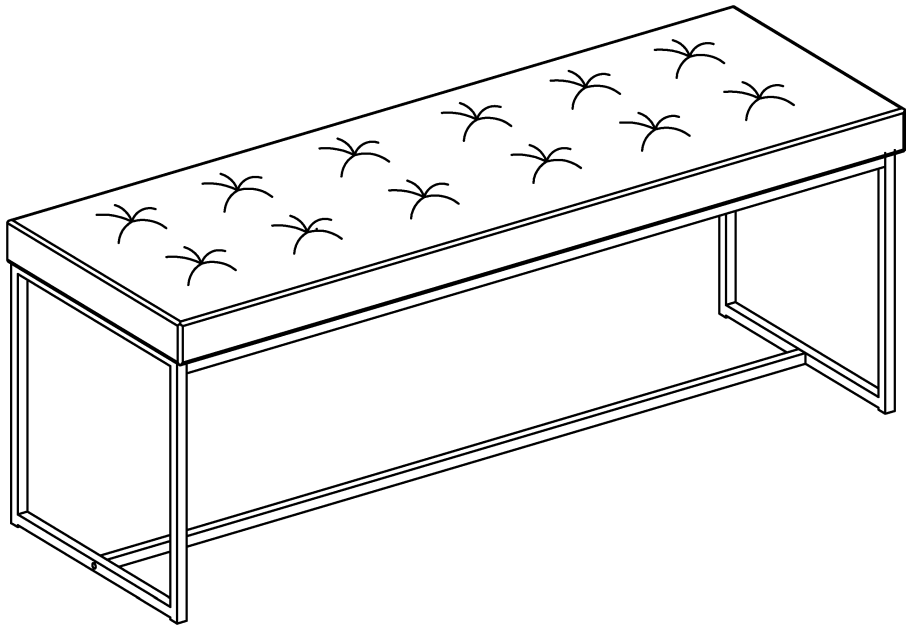

# General Assembly Guidelines

- I. Ensure that all parts and hardware are available before beginning assembly.
- II. Follow each step carefully to ensure the proper assembly of this product.
- III. Two people are recommended for ease in the assembly of this product.
- IV. The main type of hardware used to assemble this product is: bolts.
- V. Power tools should not be used to assemble this product .

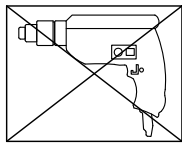

# Parts List

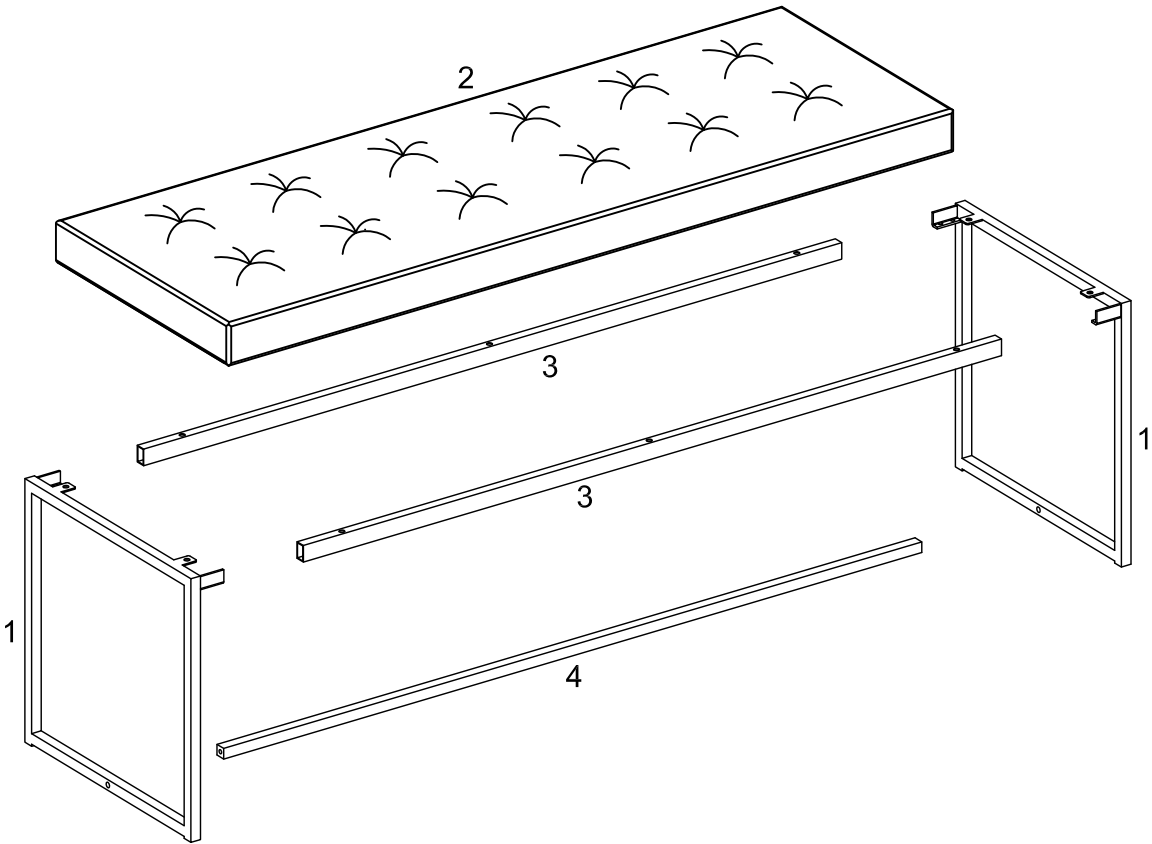

# Hardware List

A		Ø6*25mm	Bolt	2 pcs
B		Ø6*15mm	Bolt	4 pcs
C		Ø6*8mm	Bolt	8 pcs
D		Ø6*40mm	Bolt	6 pcs
E		4mm	Hex Key	1 pcs

*The hardware quantities listed above are required for proper assembly.  
Some extra hardware may also have been included.*

## Step 1

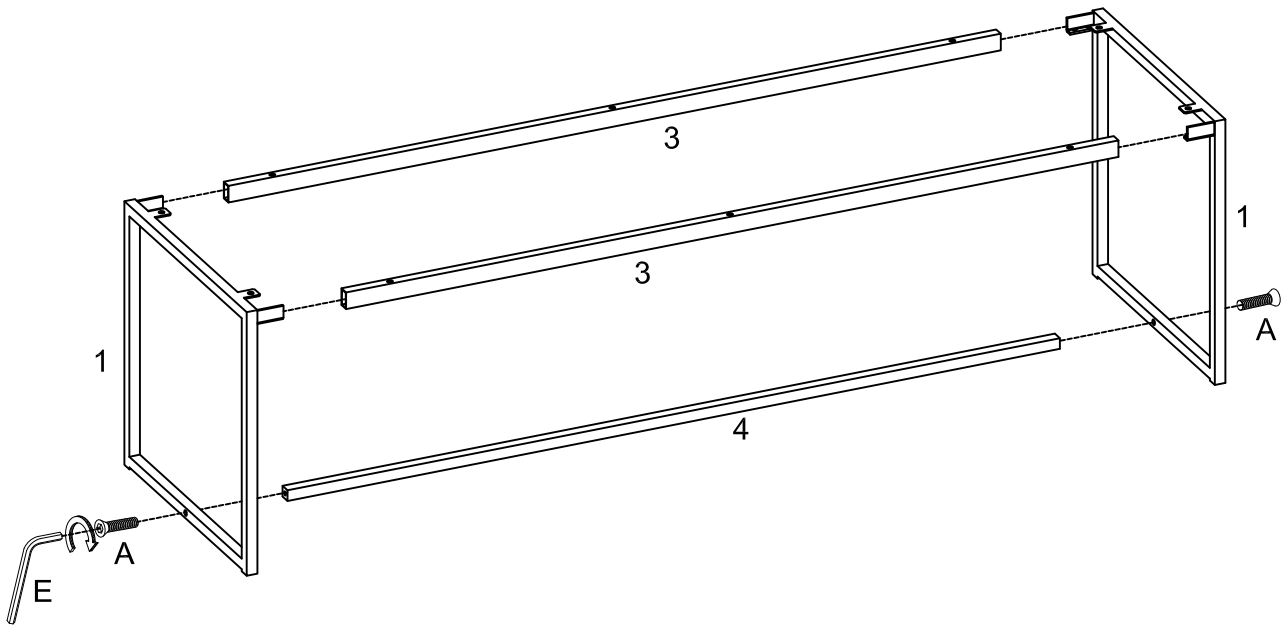

Attach part (3,4) to part (1), secure part (4) to part (1) using bolt (A) with hex key (E).

## Step 2

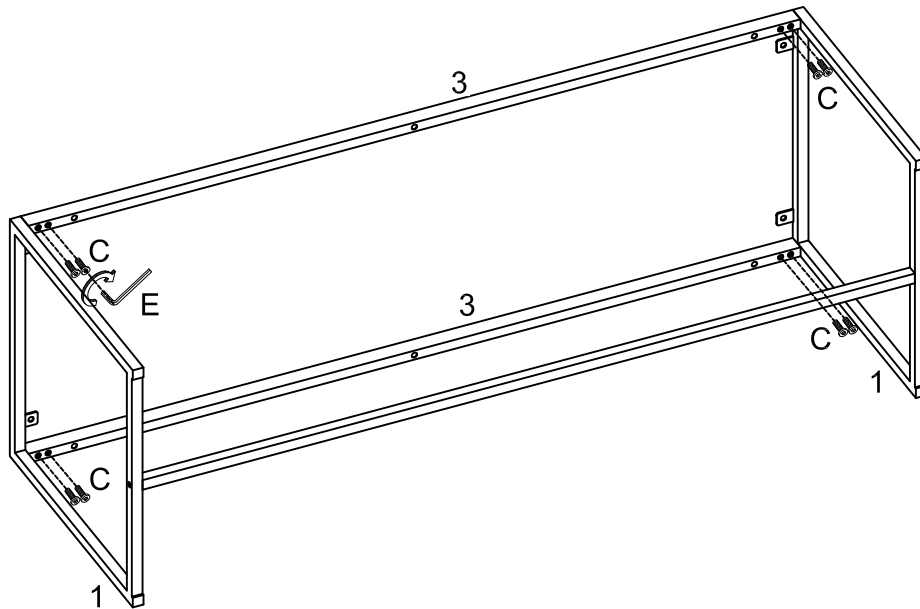

Secure part (3) to part (1) using bolt (C) with hex key (E).

## Step 3

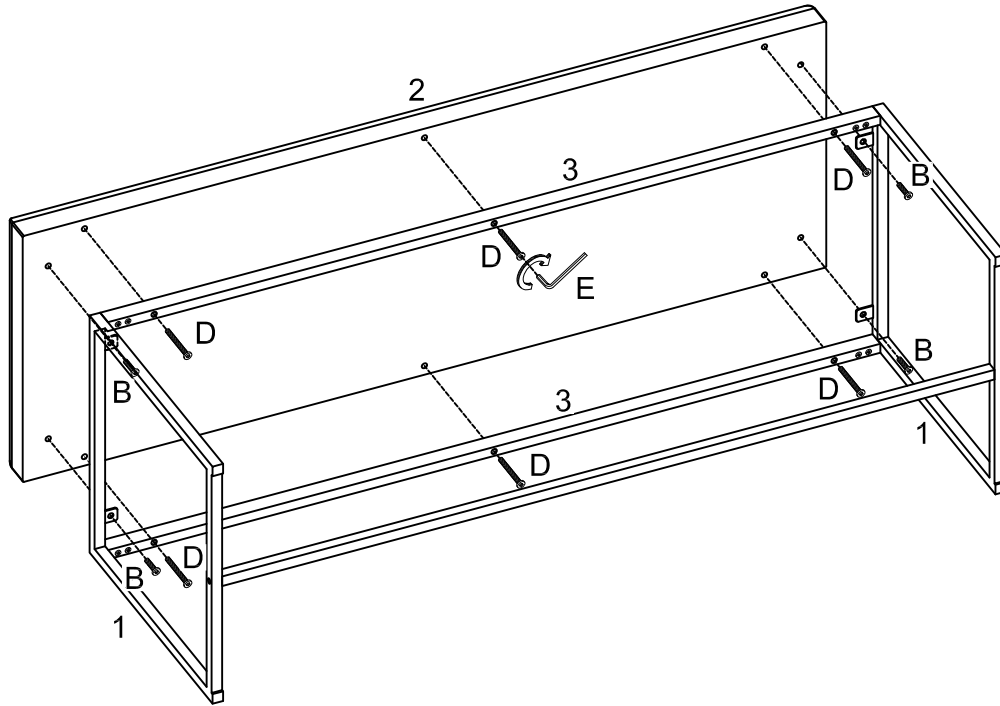

Attach part (2) to part (1,3) using bolt (B,D) with hex key (E).

## Step 4

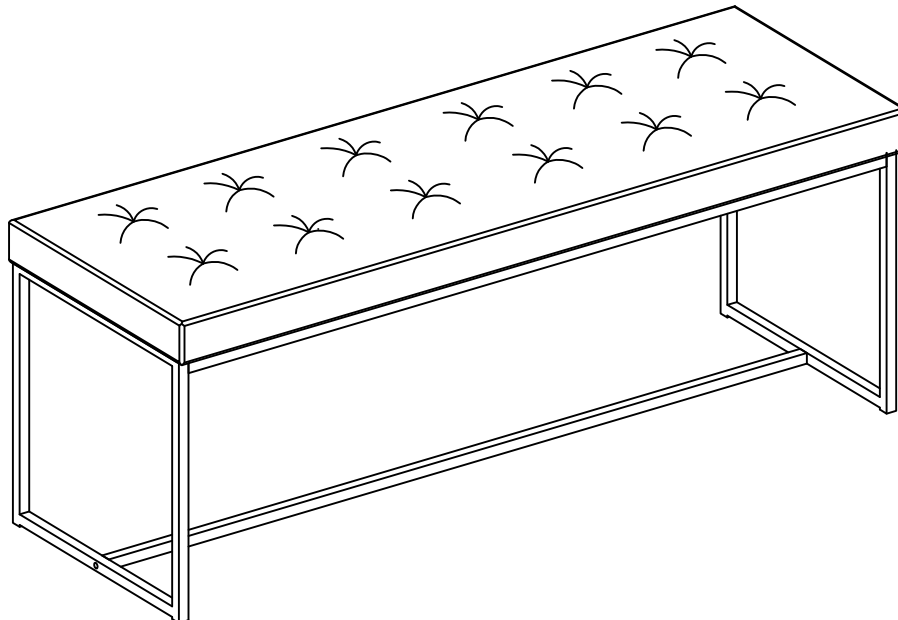

Final Assembly