

# CUUGO DNĪ "K P UVT WE VKQP

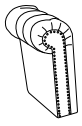

C'z'3're

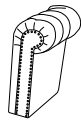

D'z'3're

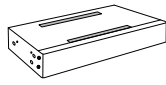

E'z'2'res

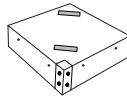

F'z'3're

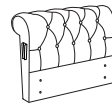

G'z'4'reu

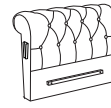

H'z'4'reu

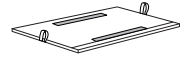

I'z'4'reu



J'z'4'reu

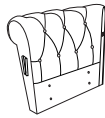

K'z'3're

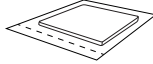

L'z'6'reu

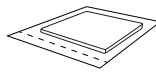

M'z'3're

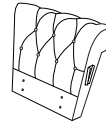

N'z'1're

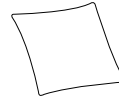

O'z'4'reu







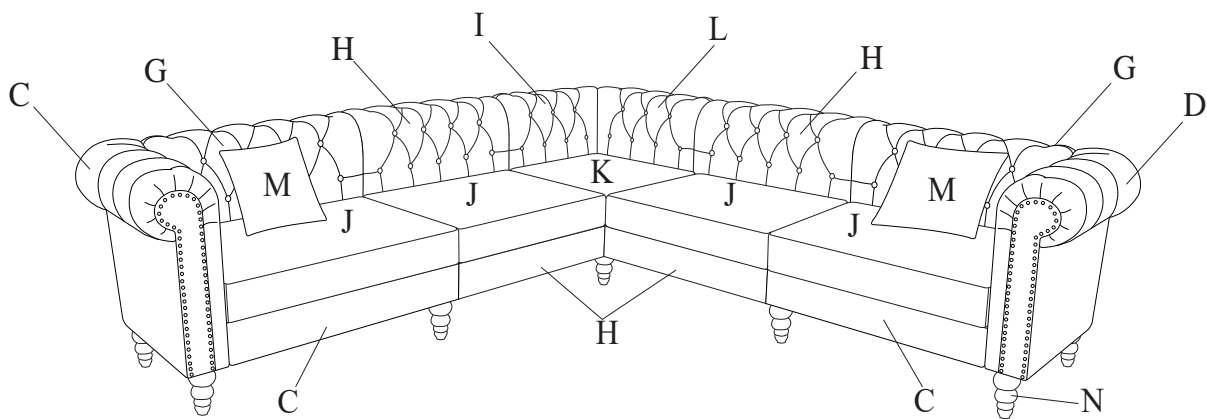



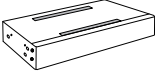

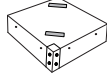

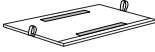

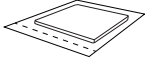
P'z'34'reu

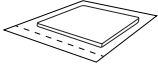



Rngcug'tgcf "qxgt 'yj g'kputwekpu. 'k'y kn'dg'c'ko g/ucxgt 'k'p'y g'mpi 'twp0  
 P qv<Dghqtg'cuugo dnĪ . 'r rngcug'dg'wtg'v'y qtnĪqp" c'uqhw'hw'v'wt'ceg'v'q'cxqk' 'cp {  
 f co ci g'v'y g'hpkuj 0  
 Rngcug'ngcxg'dqnu'ngqupgf "wpkĪcm'dqnu'ctg'r rceg'f'dghqtg'kĪ j vgpkĪ 'eqo r ngvng'0

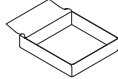
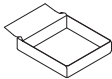



**PACK LIST CARTON A:**

Part#	Picture	Description	QTY	Part#	Picture	Description	QTY
C		Middle Seat Frame	2	①		Plastic Washer	12
D		Corner Seat Frame	1	②		Support Bar	8
G		Seat Panel	2	③		Bolt (M8*40MM)	20
J		Seat Cushion Package	4	④		Bolt (M8*50MM)	2
K		Corner Seat Cushion Package	1	⑤		Flat Washer	22
O		Rimny	4	⑥		Spring Washer	22
N		Leg	12	⑦		Allen Wrench	1
J-Cover		PU Fabric Cover	4	K-Cover		PU Fabric Cover	1

**PACK LIST CARTON B:**

Part#	Picture	Description	QTY	Part#	Picture	Description	QTY
A		Left Armrest	1	F		Middle Seat Backrest	2
B		Right Armrest	1	H		Front Rail	2

**PACK LIST CARTON C:**

Part#	Picture	Description	QTY	Part#	Picture	Description	QTY
E		Backrest	2	L		Corner Seat Right Backrest	3
I		Corner Seat Left Backrest	3				

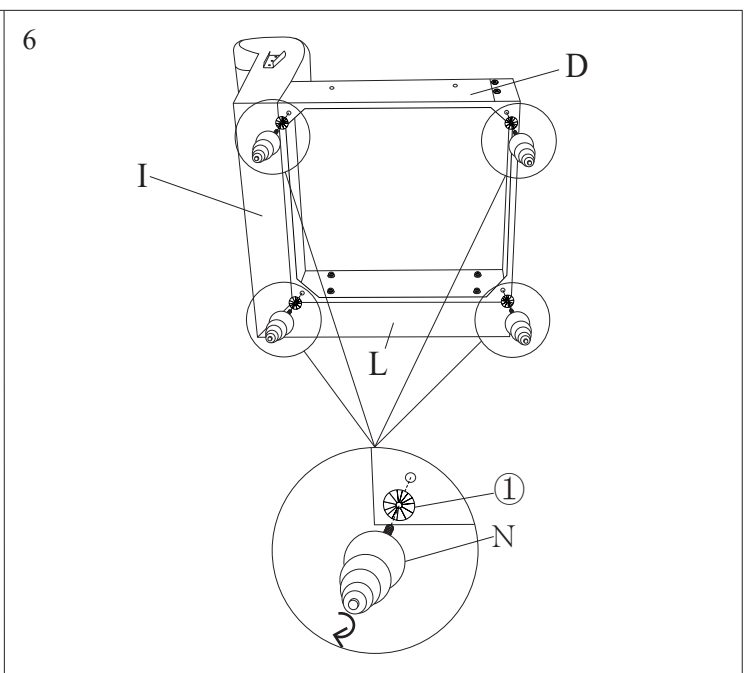
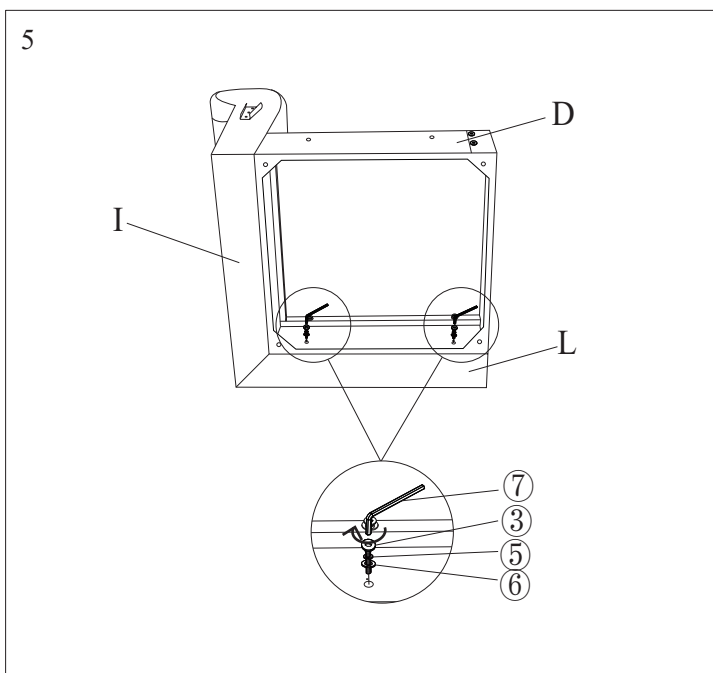
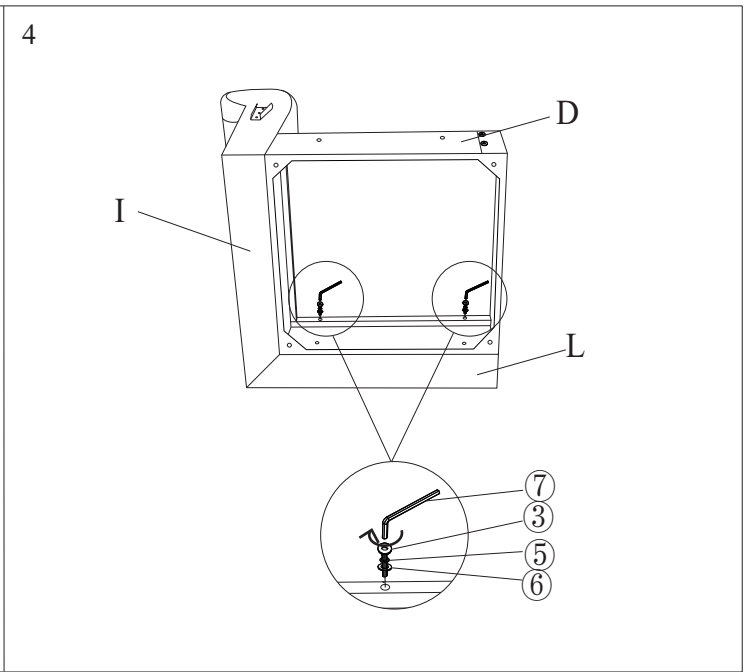
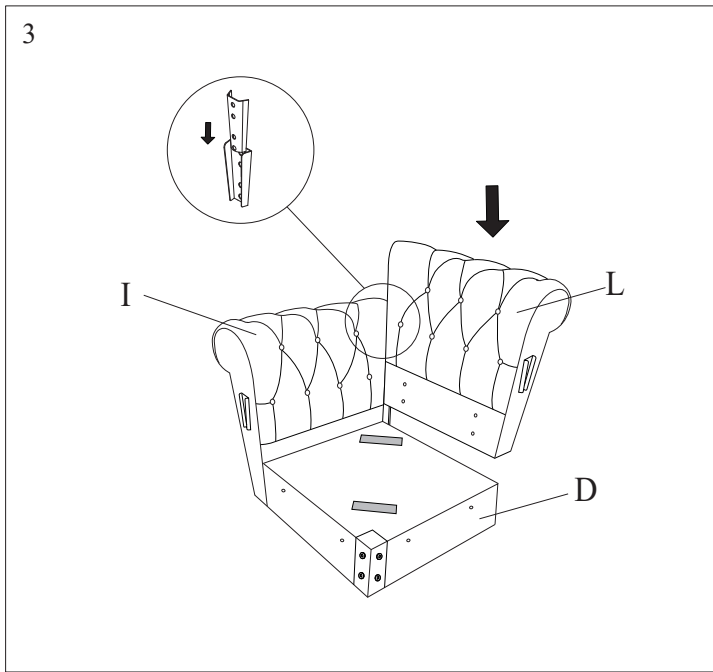
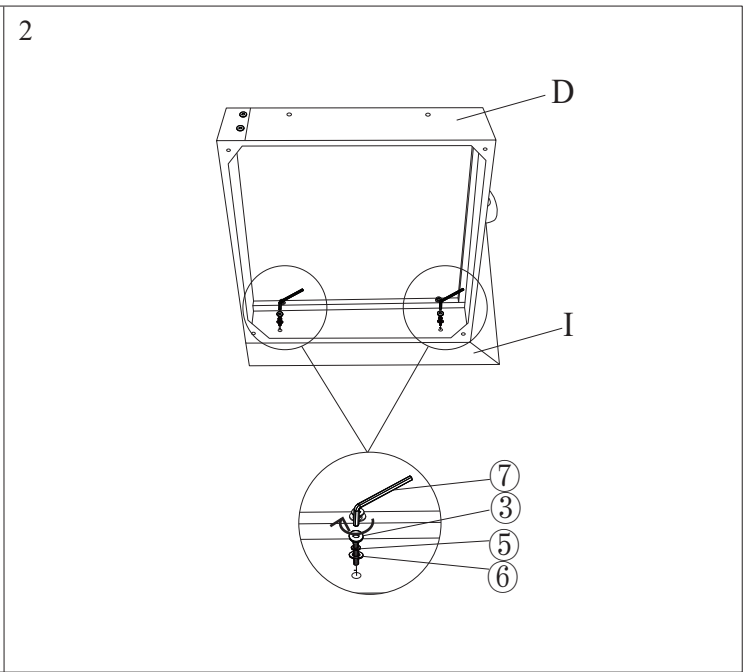
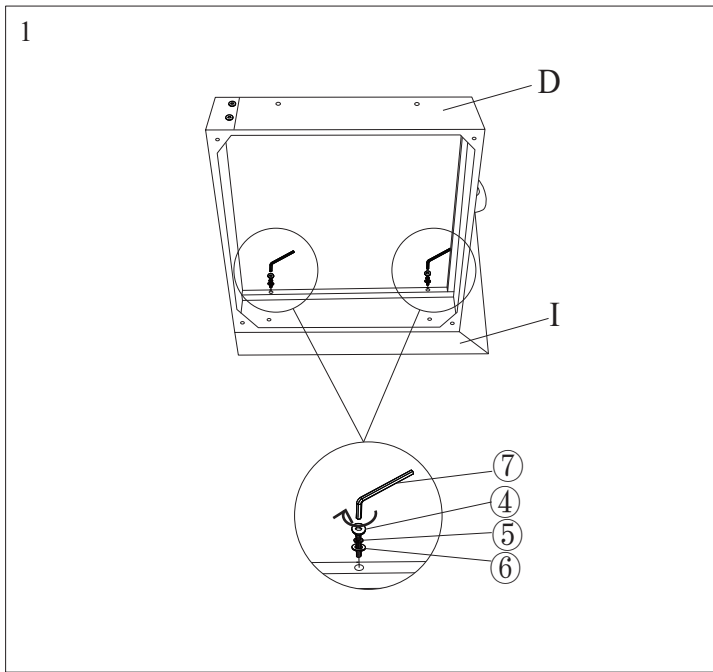

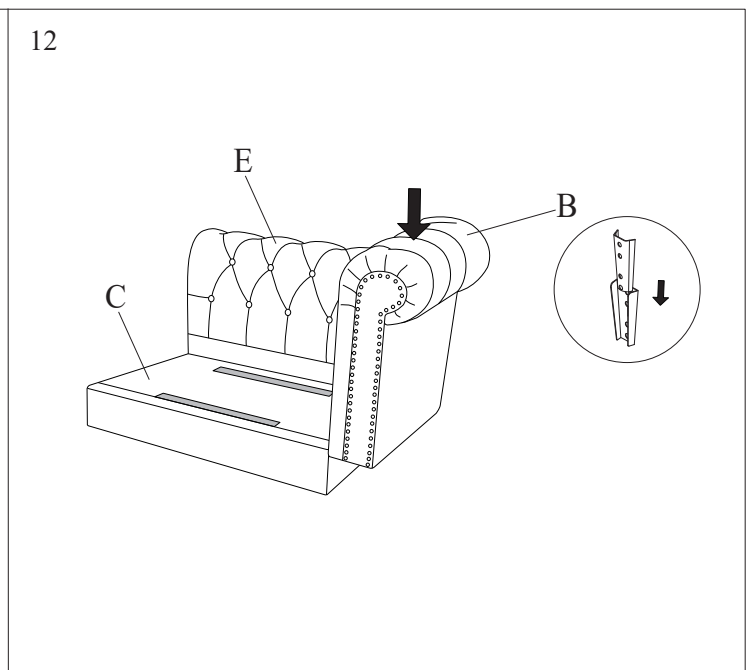
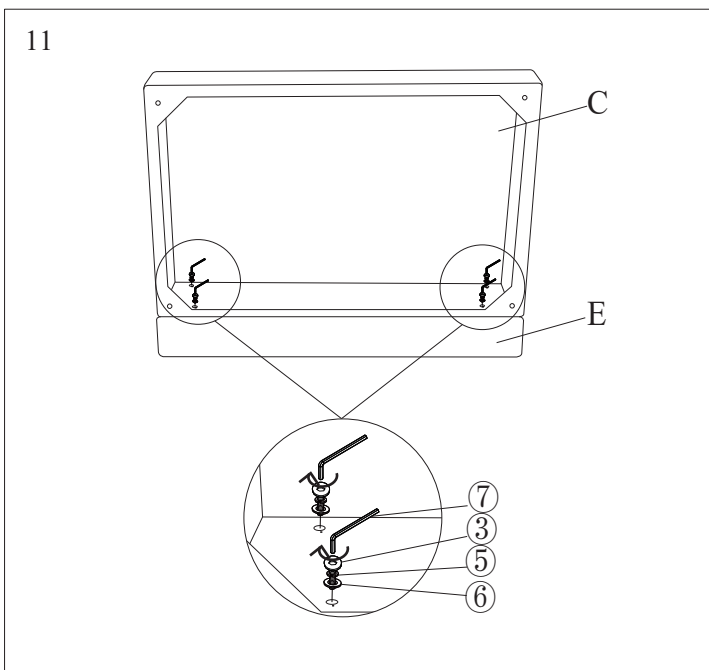
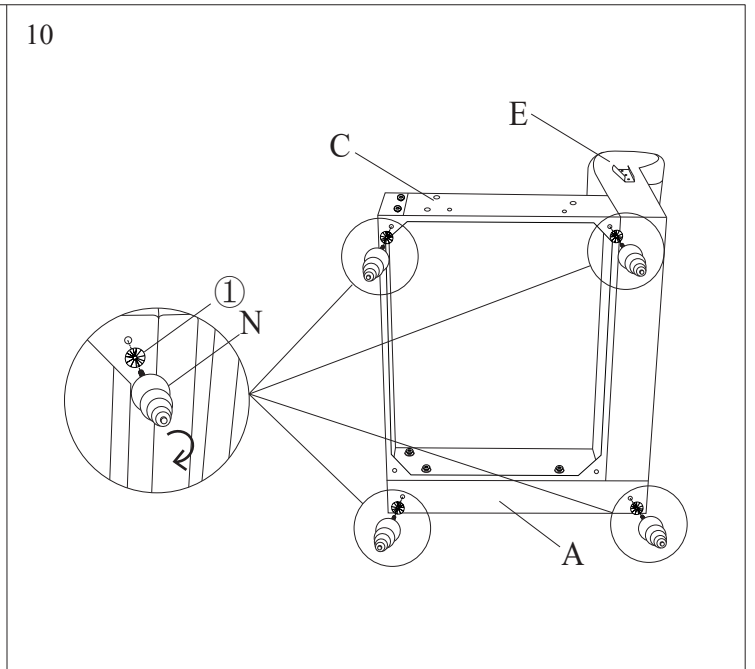
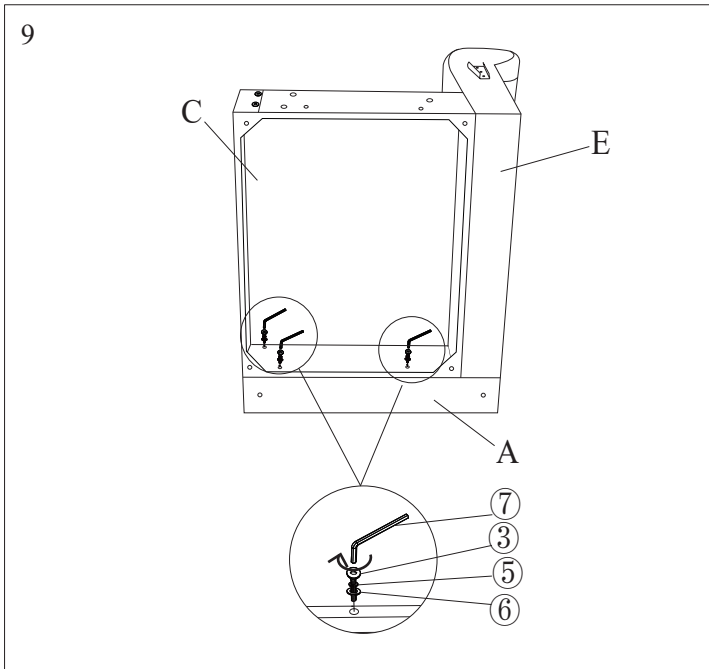
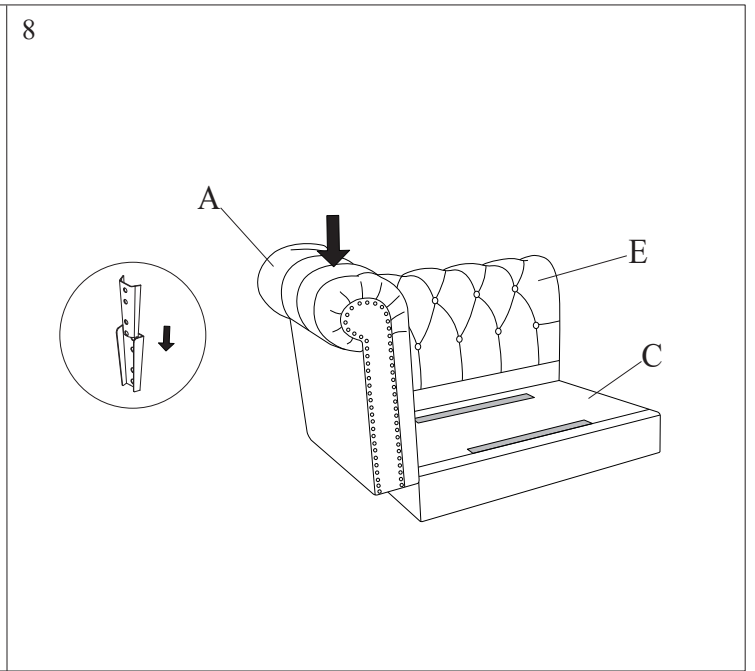
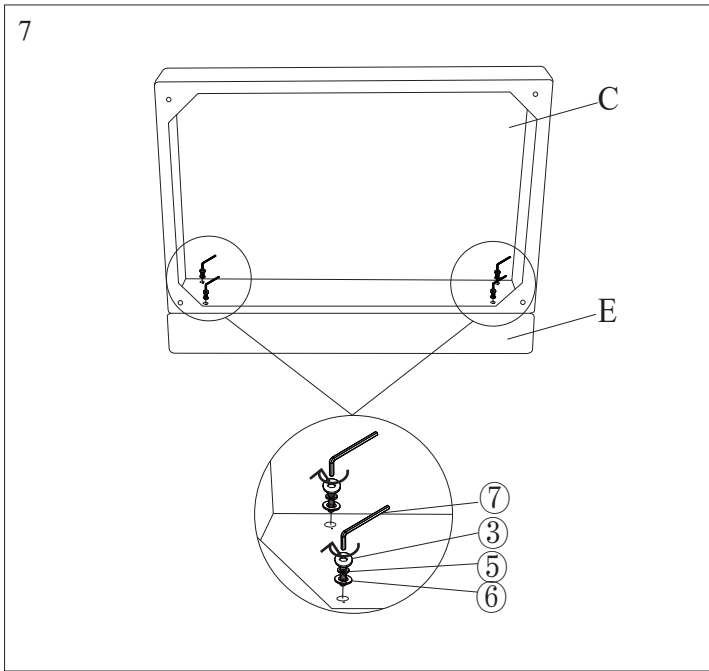

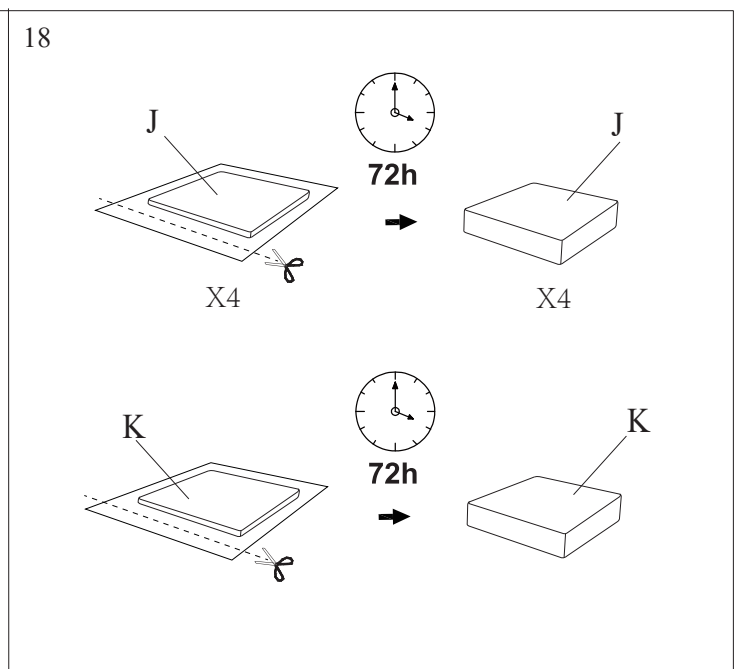
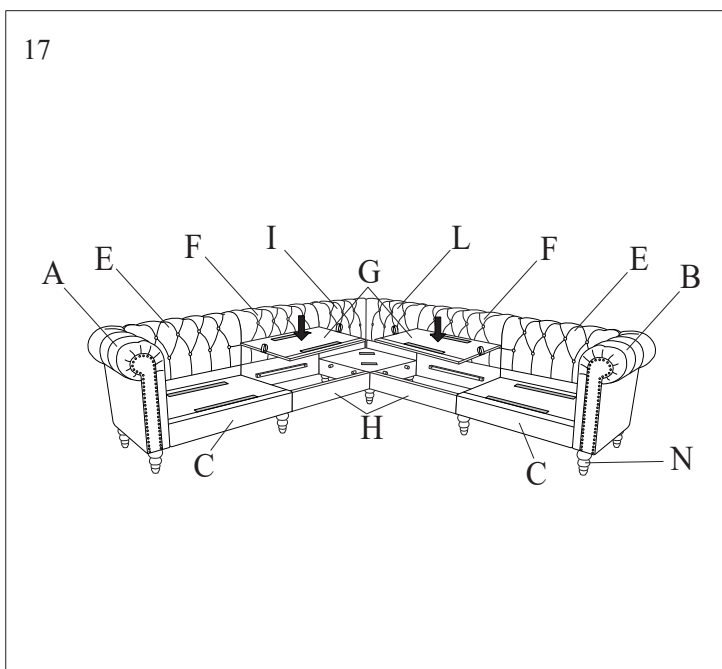
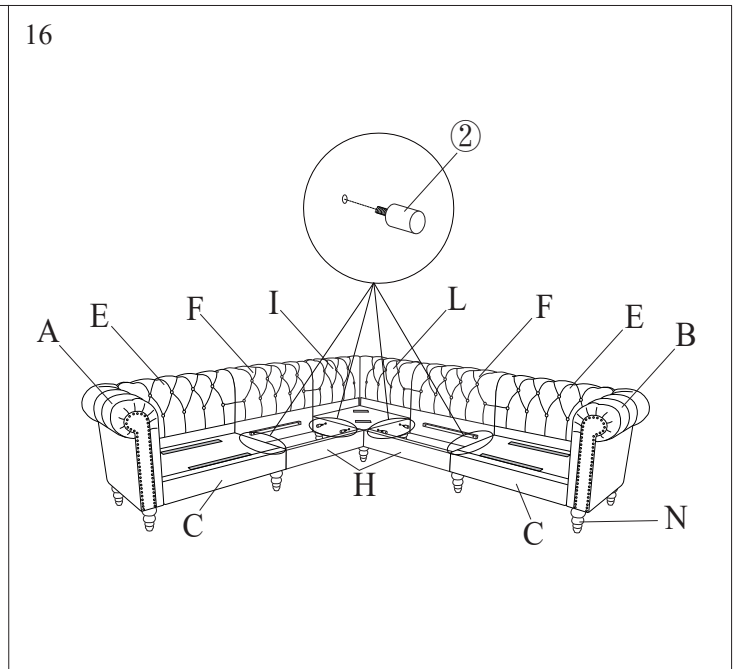
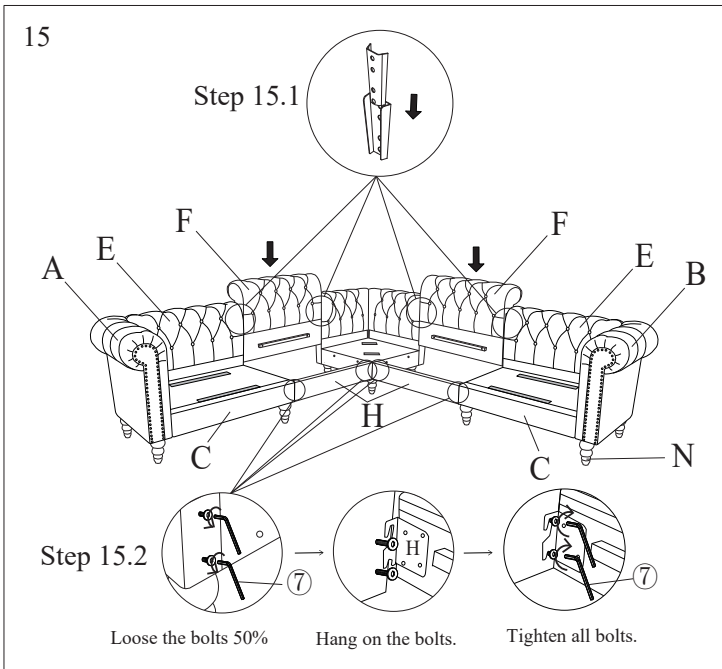
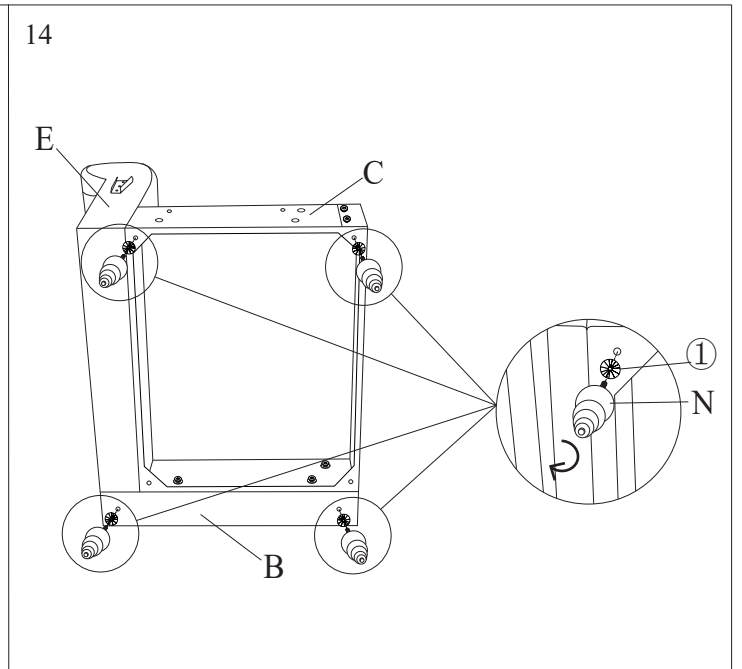
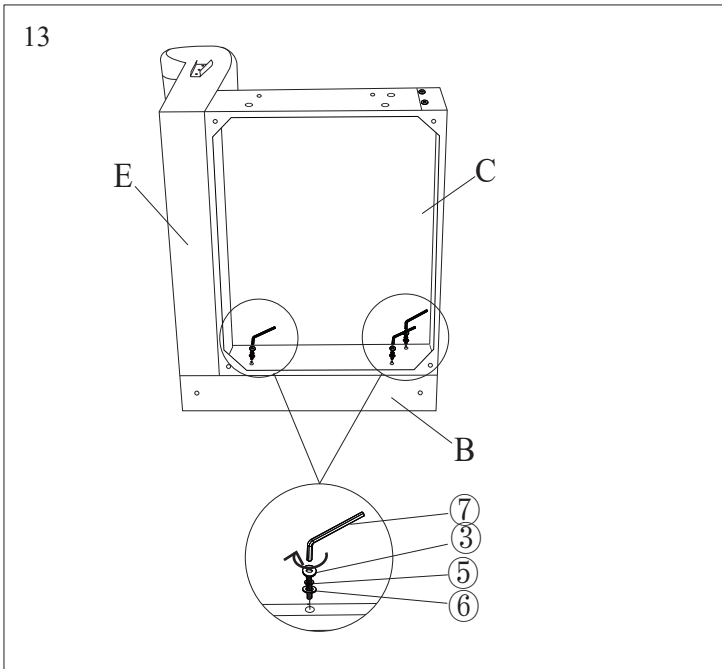

19

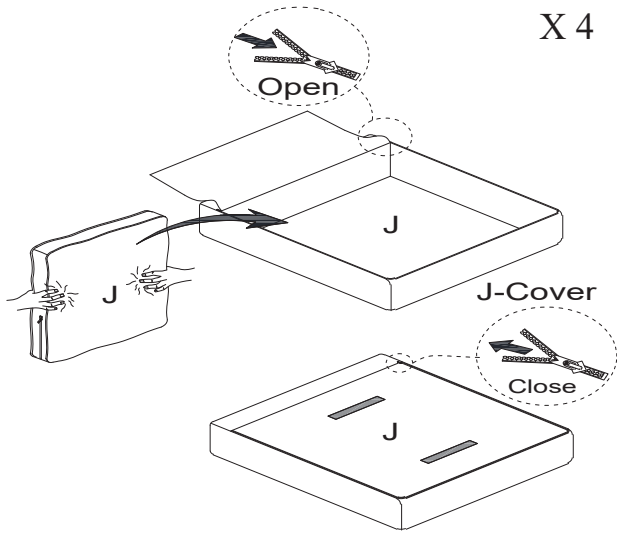

20

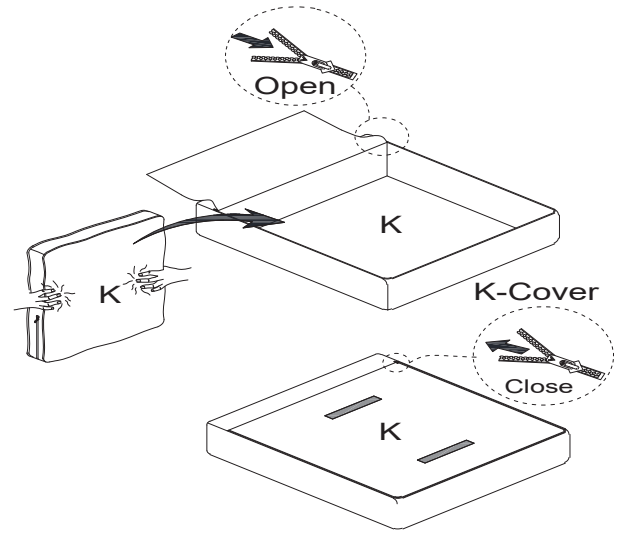

NOTE:

If you purchase the sofa made of fabric material, after completing STEP 18, proceed to STEP 21.

If you purchase the sofa made of PU material, after completing STEP 18, proceed to STEP 19-20, then to STEP 21.

21

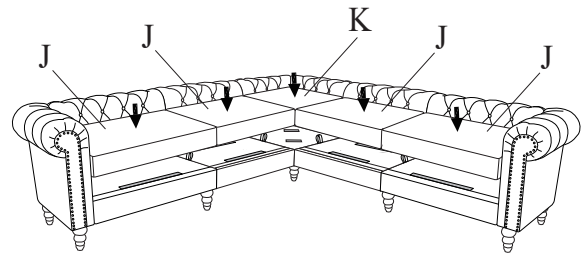

22

