

# INSTALLATION INSTRUCTIONS

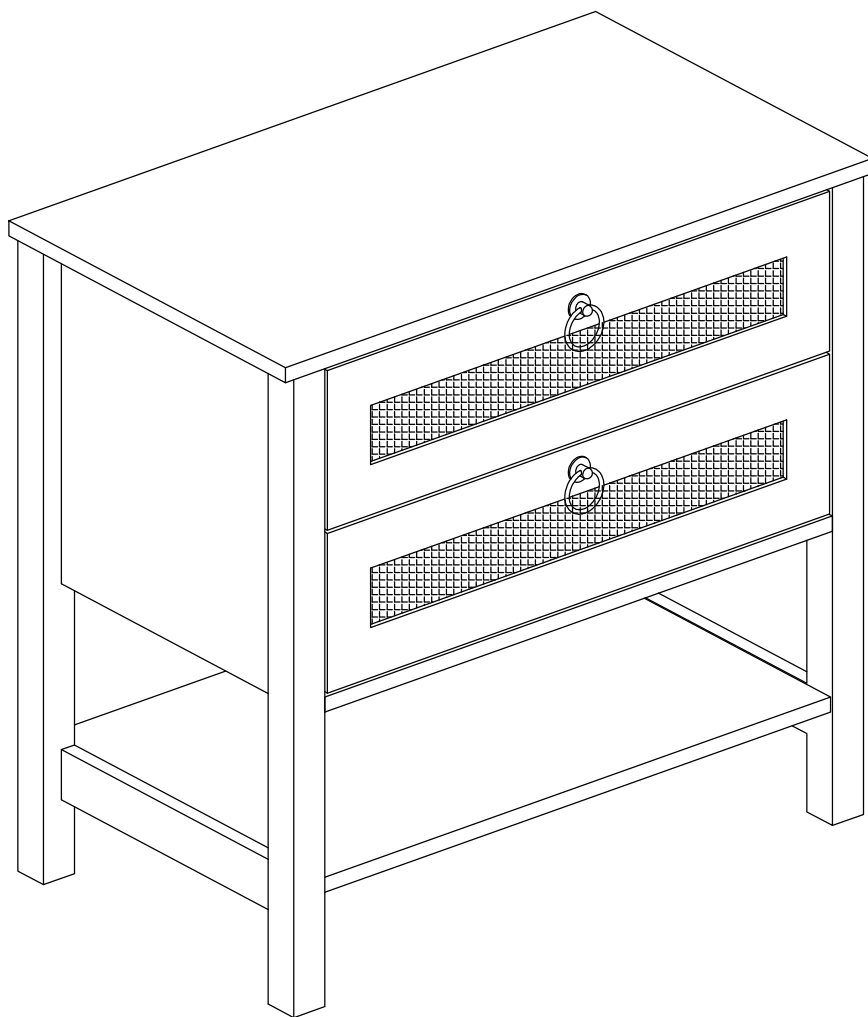

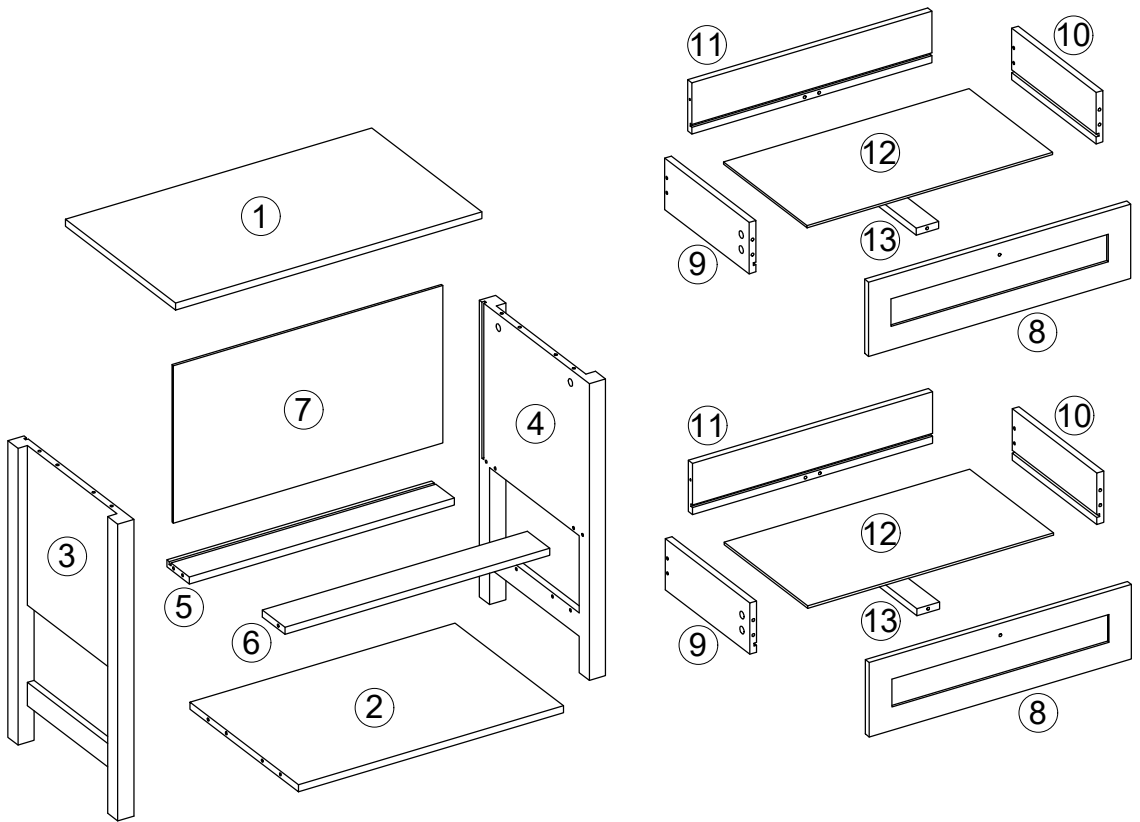

## USAGE PRECAUTIONS

- 1、 Avoid children climbing or sitting on the product.
- 2、 Avoid putting this product in a humid environment.
- 3、 If the ground is uneven, the bottom adjustment foot pad of this product can be used to adjust and place the product horizontally







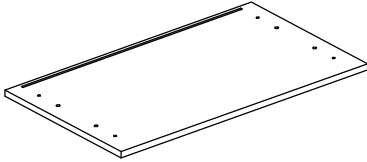
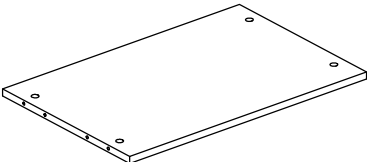
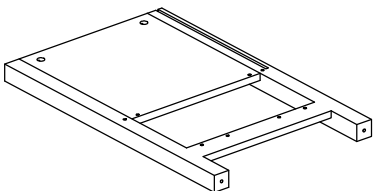
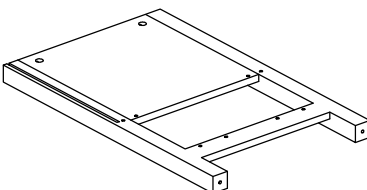
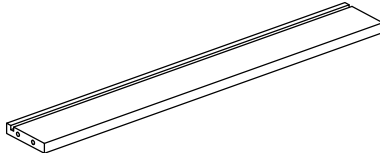
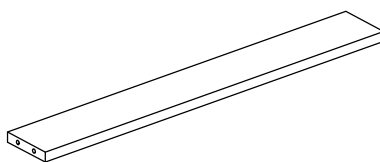
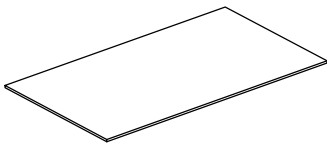
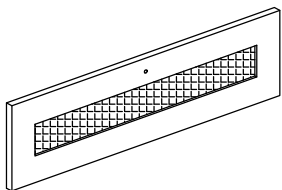
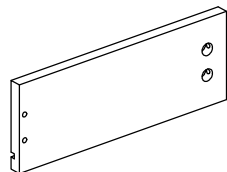
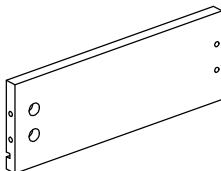
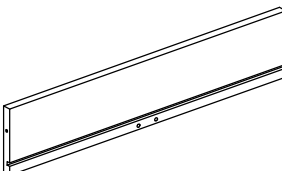
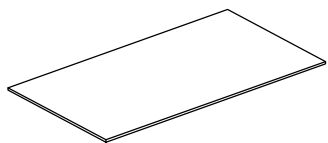
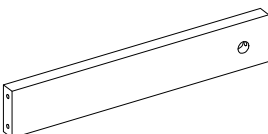





If you have any questions, please contact online customer service, we will solve your problem as soon as possible.

Please dispose of the product packaging materials properly.

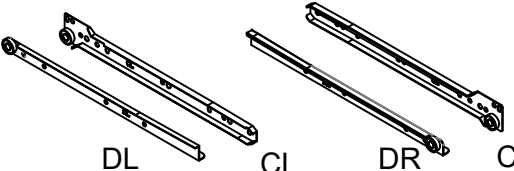
# LIST OF ACCESSORIES

<p>① 1PC</p> 	<p>② 1PC</p> 	<p>③ 1PC</p> 
<p>④ 1PC</p> 	<p>⑤ 1PC</p> 	<p>⑥ 1PC</p> 
<p>⑦ 1PC</p> 	<p>⑧ 2PCS</p> 	<p>⑨ 2PCS</p> 
<p>⑩ 2PCS</p> 	<p>⑪ 2PCS</p> 	<p>⑫ 2PCS</p> 
<p>⑬ 2PCS</p> 		

# LIST OF ACCESSORIES

<p><b>A</b></p>  <p>φ5x40</p> <p>x12+1PCS</p>	<p><b>B</b></p>  <p>φ6x40</p> <p>x8+1PCS</p>	<p><b>C</b></p>  <p>x26+2PCS</p>
<p><b>D</b></p>  <p>φ15x10</p> <p>x26+2PCS</p>	<p><b>E</b></p>  <p>x2PCS</p>	<p><b>F</b></p>  <p>M4x18</p> <p>x2PCS</p>
<p><b>G</b></p>  <p>φ3.0*12</p> <p>x8+1PCS</p>	<p><b>H</b></p>  <p>DL CL DR CR</p> <p>300*1.0</p> <p>x2PCS</p>	
<p><b>I</b></p>  <p>φ3.0*14</p> <p>x6+1PCS</p>	<p><b>J</b></p>  <p>x8+2PCS</p>	<p><b>K</b></p>  <p>x4PCS</p>
<p><b>L</b></p>  <p>3mm</p>	<p><b>M</b></p>  <p>φ3.5*12</p> <p>x8+1PCS</p>	

## PRE-INSTALLATION

- 1、 Check that all accessories are complete before installation.
- 2、 Strictly follow these instructions to ensure that the installation steps are correct.
- 3、 Ensure that all screws and other accessories are away from children during installation.
- 4、 Power tools should not be used to assemble this product.

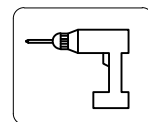

5. Do not tighten bolts / screws completely until all bolts / screws are lined up and inserted into holes. Do not over tighten screws and bolts to avoid stripping.

# INSTALLATION STEPS



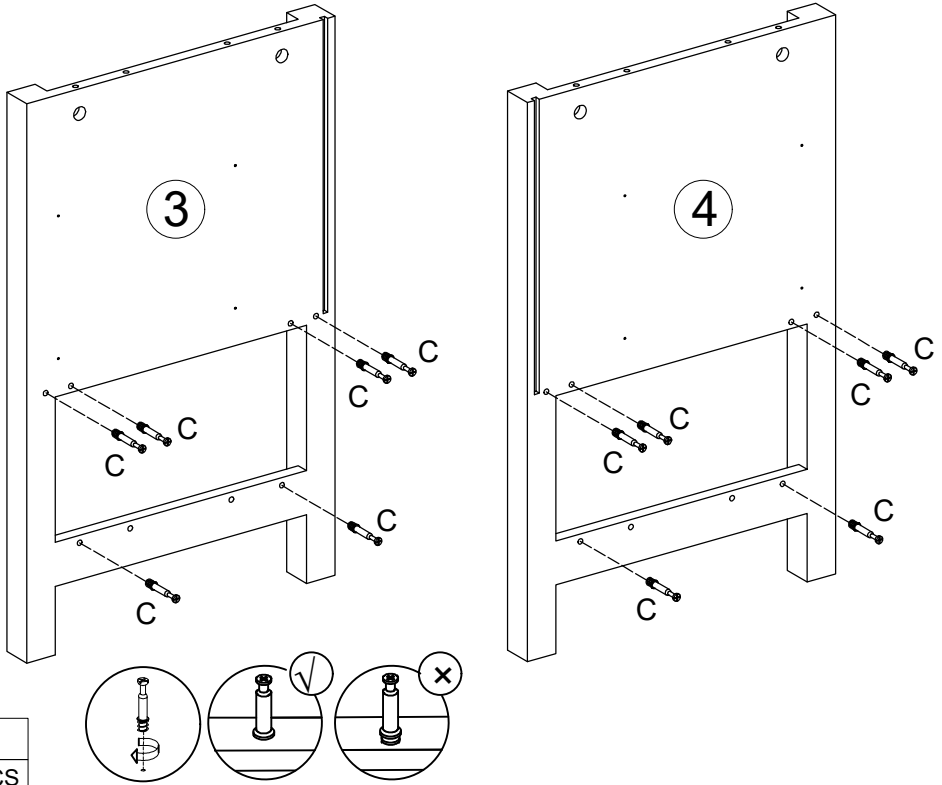

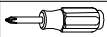
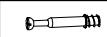
## STEP 1

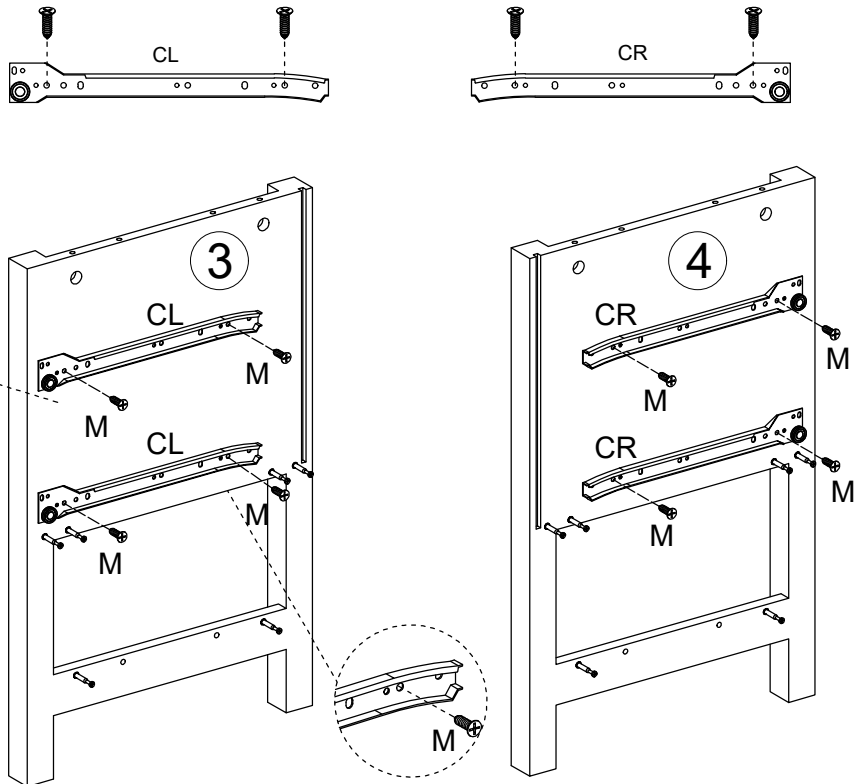

	L
	C x12PCS

## STEP 2



	L
	M x8PCS
	H CLx2PCS
	H CRx2PCS

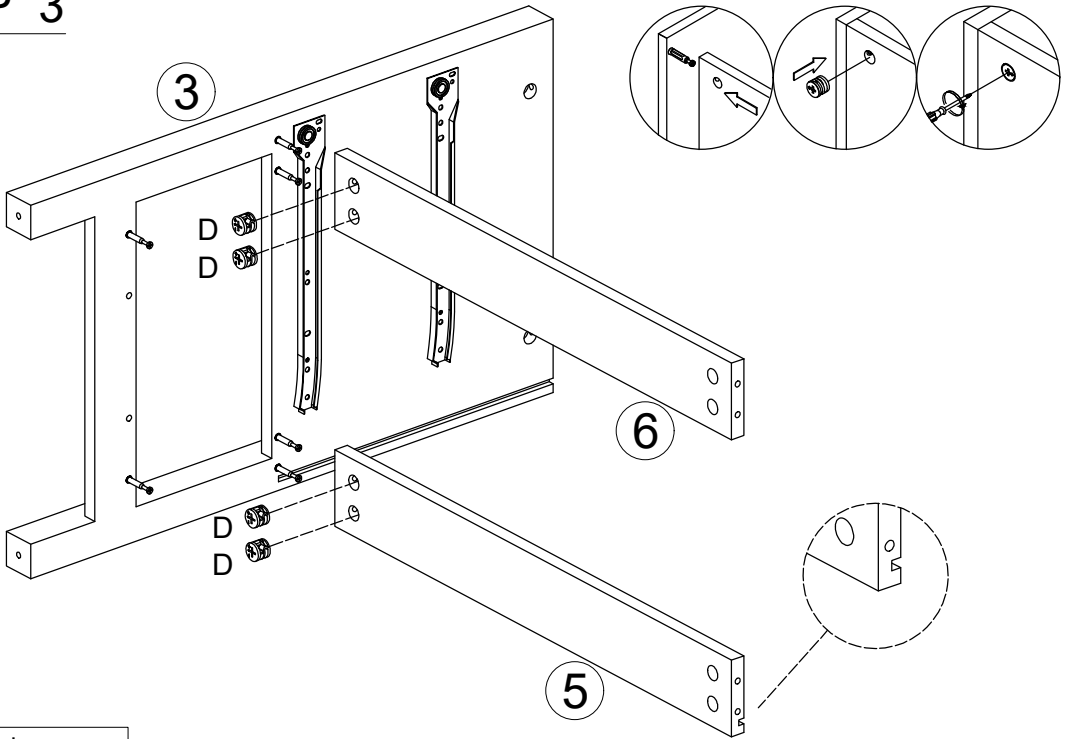

# STEP 3



	L
	D x4PCS

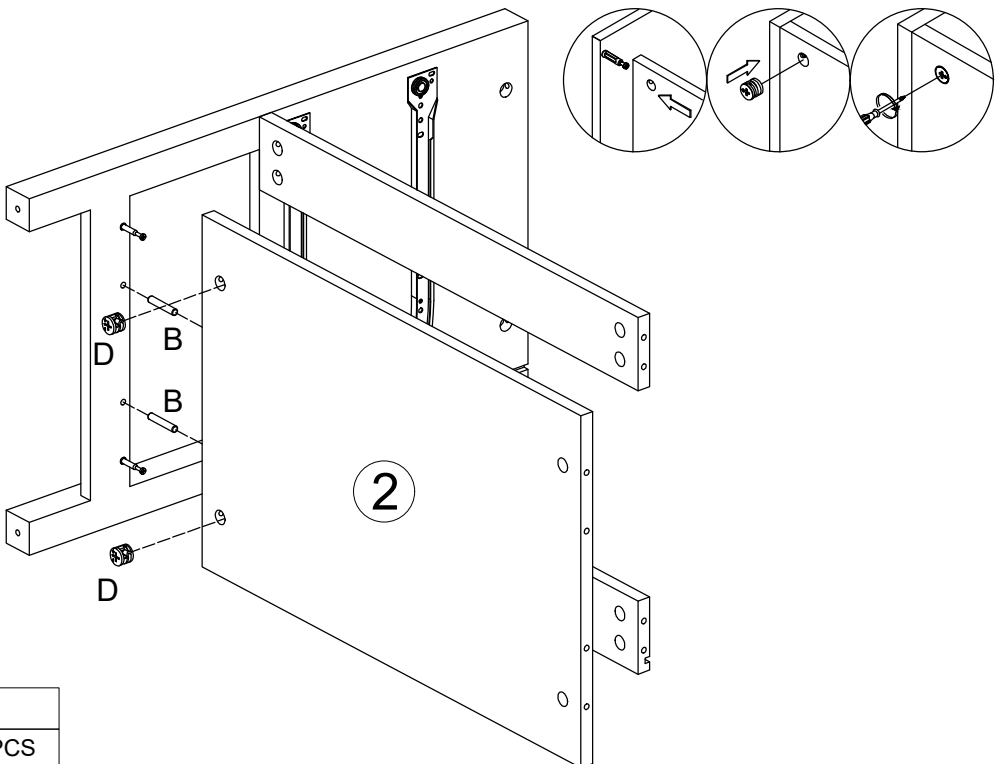

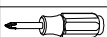
# STEP 4

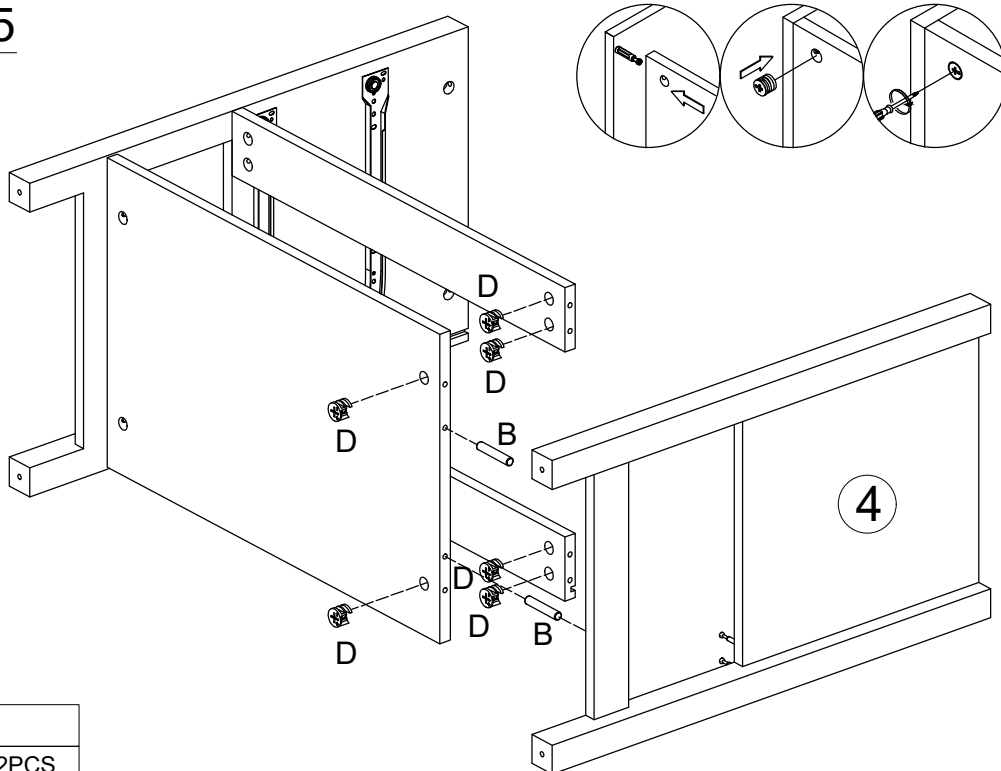

	L
	B x2PCS
	D x2PCS

## STEP 5



	L
	B x2PCS
	D x6PCS

## STEP 6

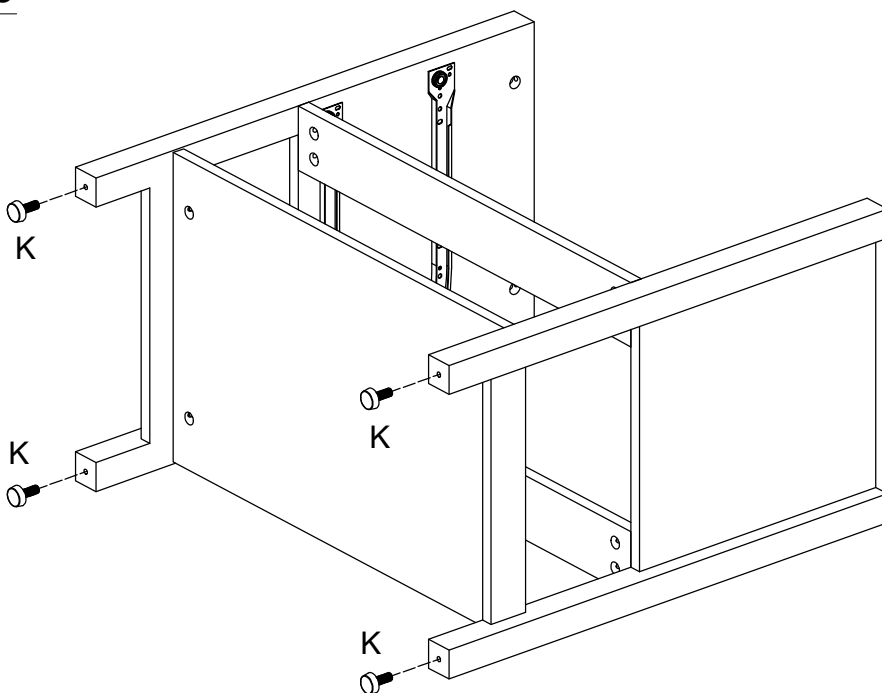

	K x4PCS
--	---------

# STEP 7

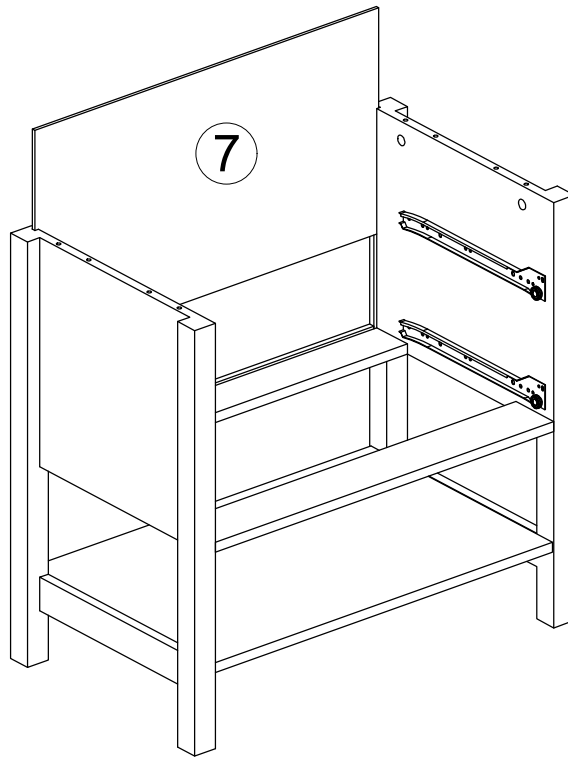



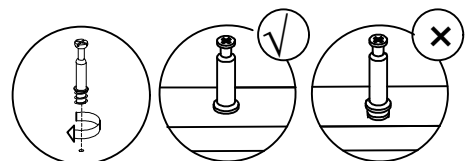
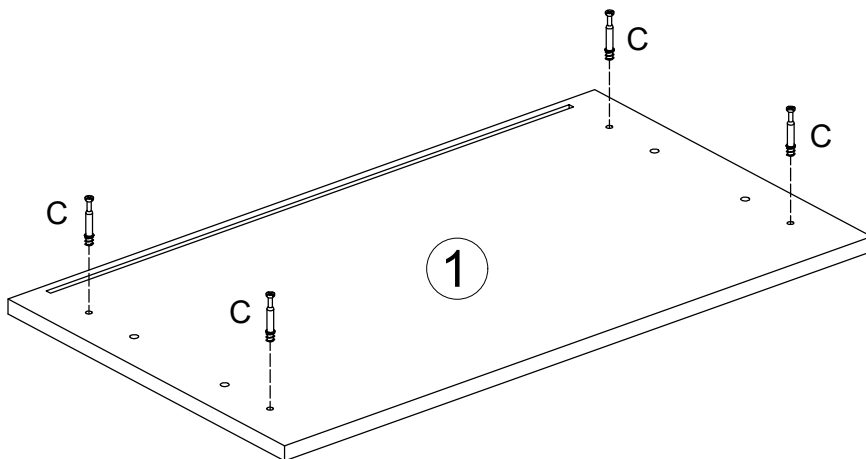

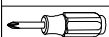
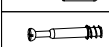
# STEP 8

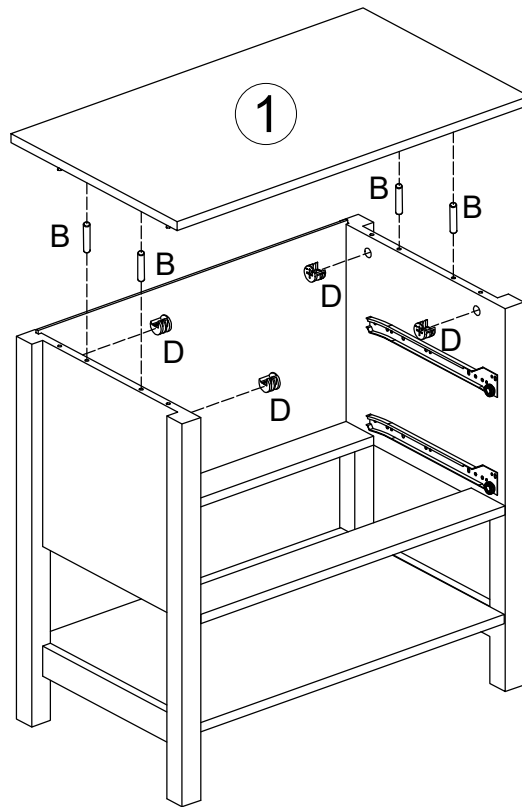
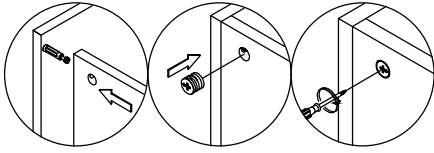

	L
	C x4PCS



# STEP 9

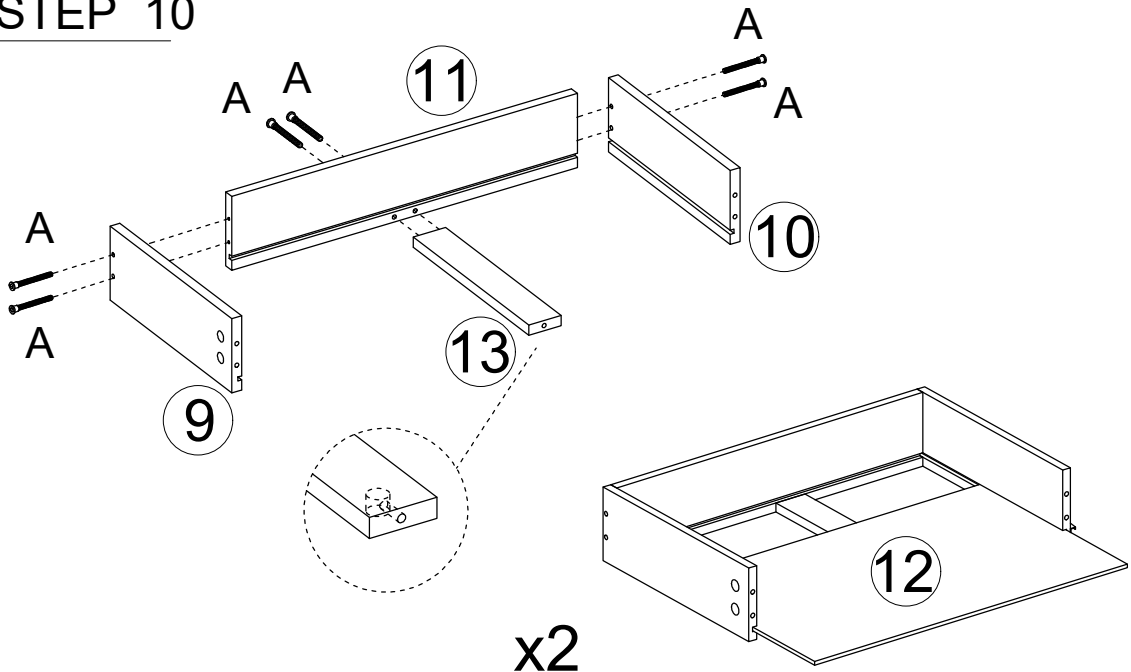

	L
	B x4PCS
	D x4PCS

# STEP 10



	L 3mm
	A x12PCS

# STEP 11

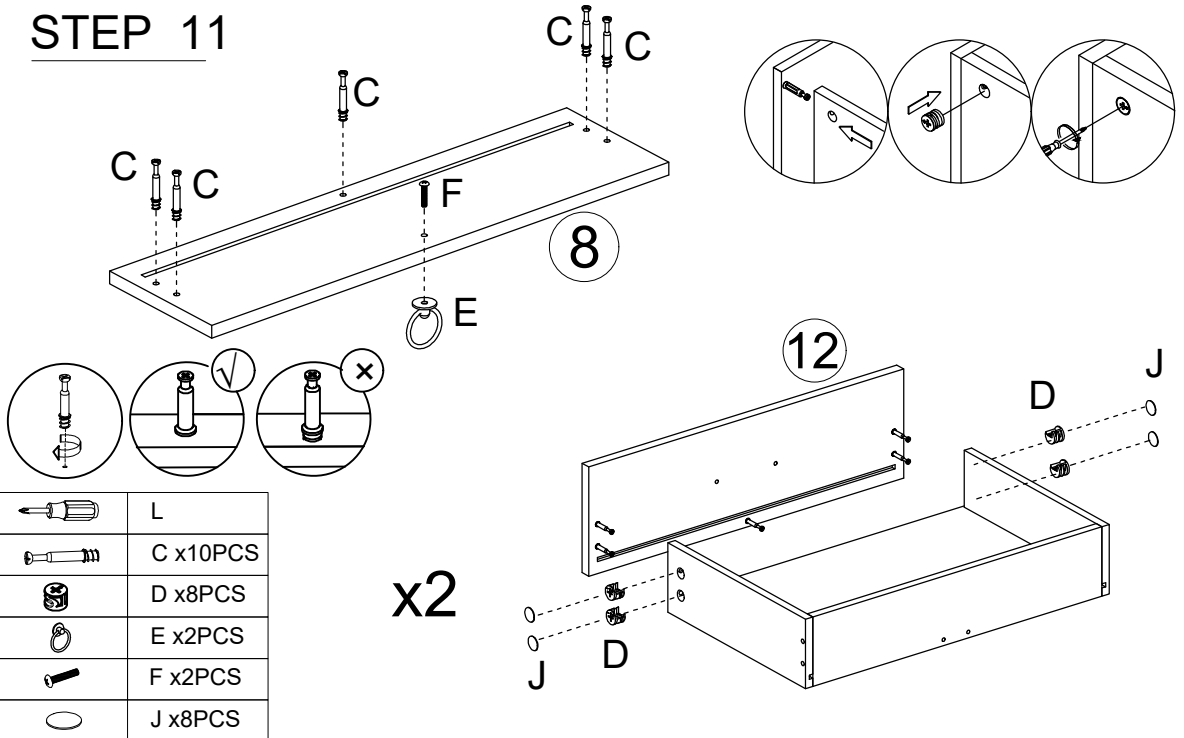

# STEP 12

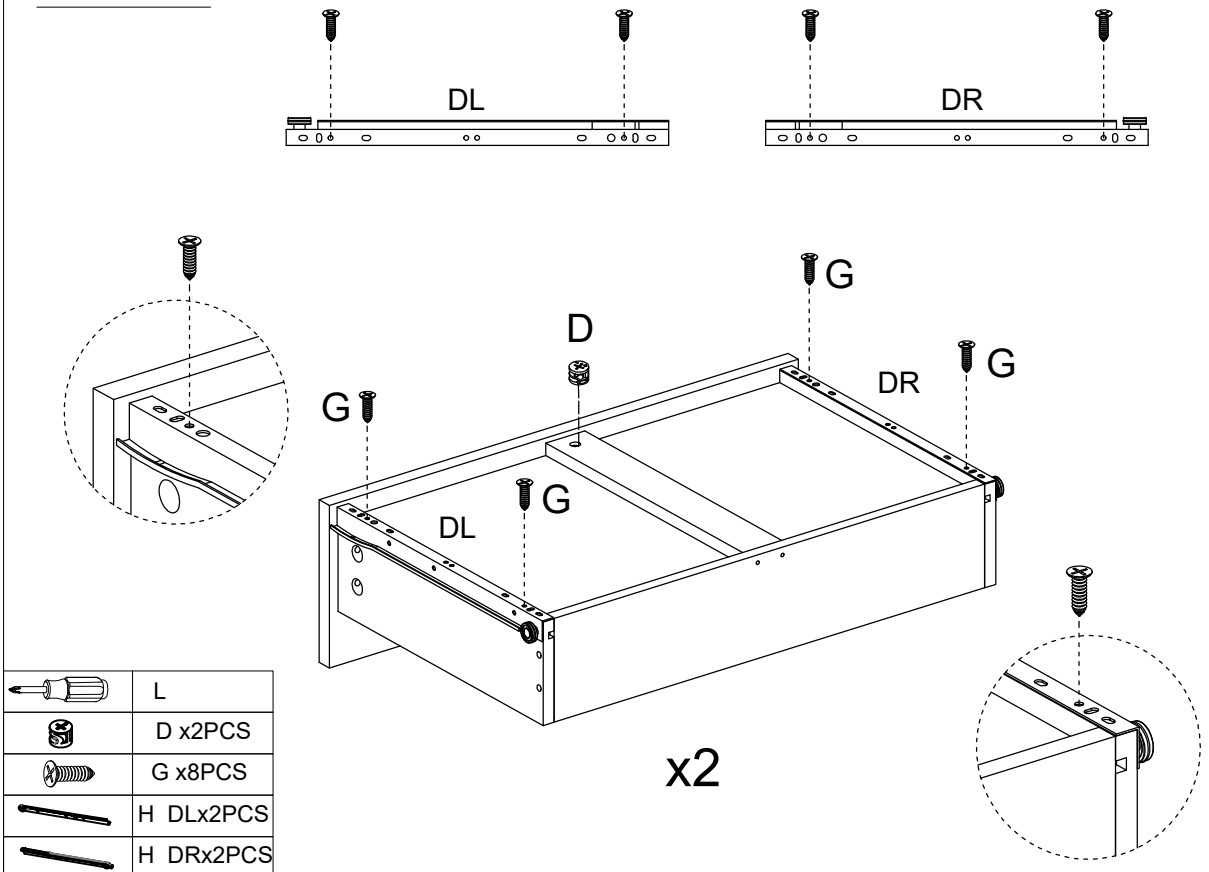

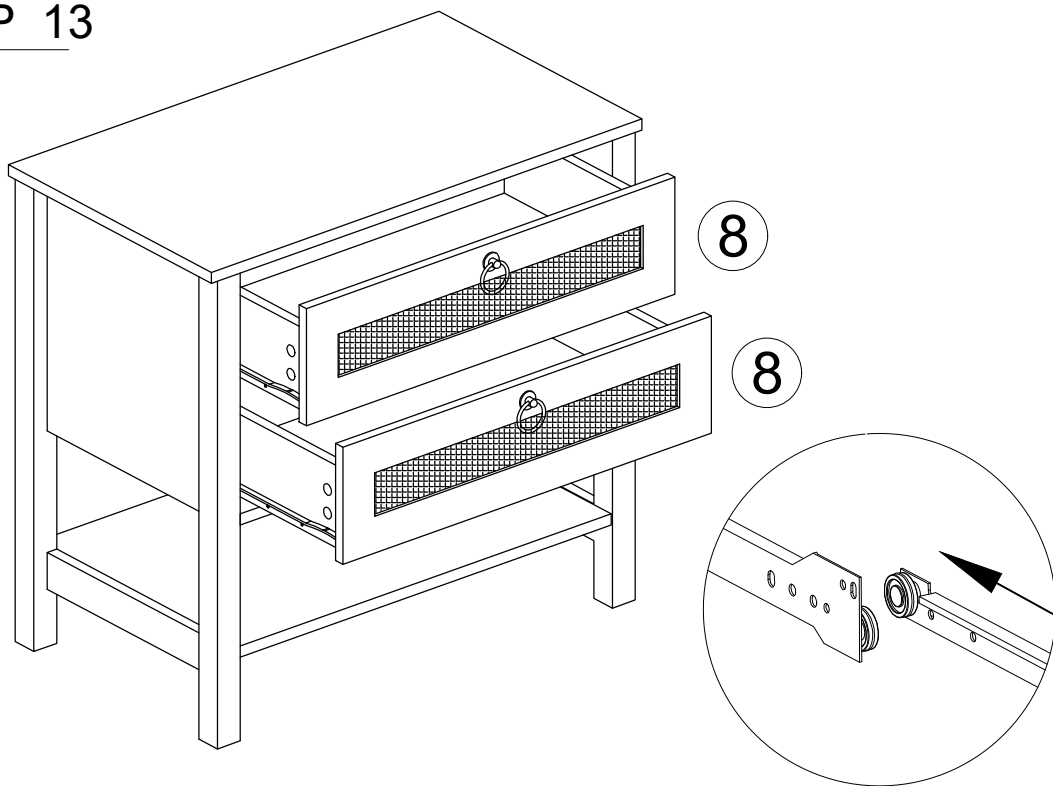

## STEP 13

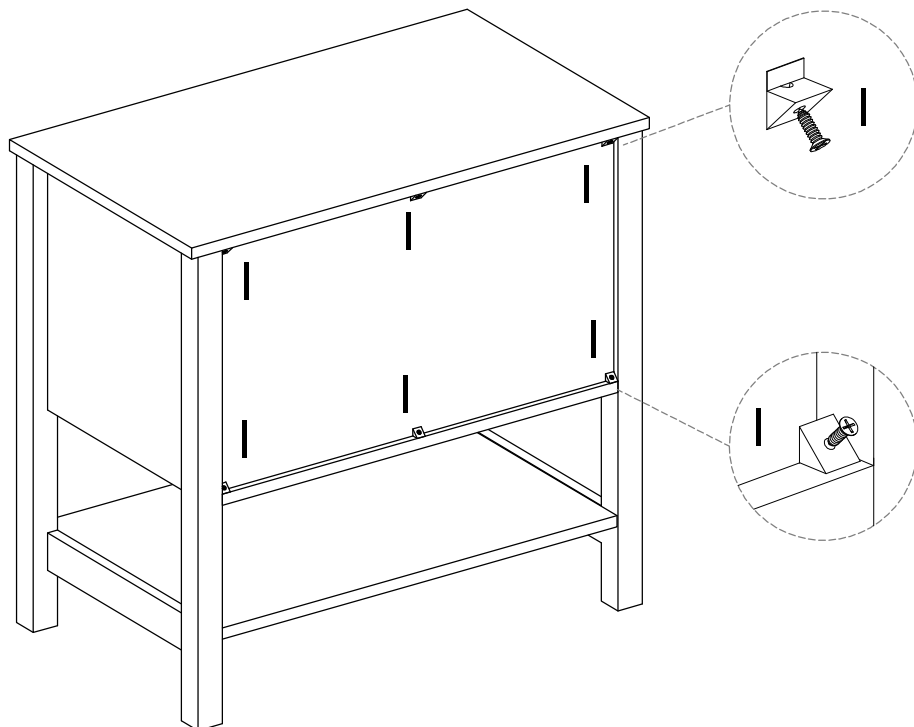

## STEP 14



	L
	1 x6PCS

STEP 15

