

WALTER 6 DRAWER MASTER DRESSER

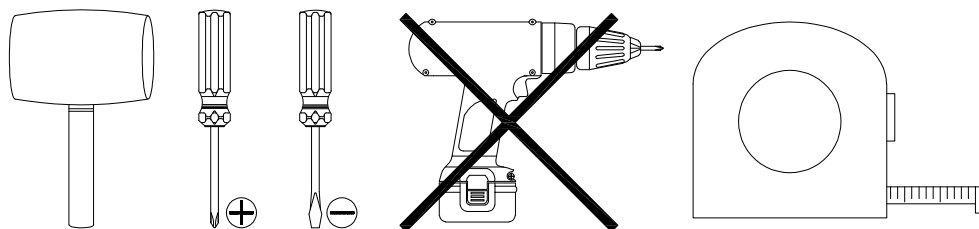



*TOOL REQUIRED
HERRAMIENTA REQUERIDA*



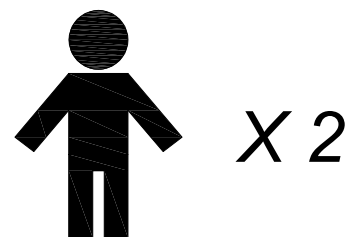

*PERSON REQUIRED
PERSONA REQUERIDA*



NOTES ON ASSEMBLY / NOTAS SOBRE EL MONTAJE

- To ensure ease of assembly read all instruction before assembly and follow step by step illustration.
- Keep instruction for future use.
- Adult assembly required.  2 person required. 
- Due to the presence of small parts during assembly, keep out of reach of children until assembly is complete.

- Para garantizar la facilidad de montaje, lea todas las instrucciones antes del montaje y siga las ilustraciones paso a paso.
- Conserve las instrucciones para una utilización posterior.
- Requiere montaje por parte de un adulto.  Se requiere 2 personas. 
- Debido a la presencia de piezas pequeñas durante el montaje, manténgalas fuera del alcance de los niños hasta que se complete el montaje.

IMPORTANT - PLEASE READ CAREFULLY
/ IMPORTANTE: LEA ATENTAMENTE

- Avoid putting knives, forks, and other sharp objects straight onto your furniture as they could scratch and harm the finish.
- To clean your furniture, use an absorbent cloth that is soft, dry, and free of lint. Avoid using detergents since they could include substances that react and harm the finish.
- Clean up spills quickly. Water left over a prolonged period of time may cause damage. Alcohol, perfume, nail polishes, aftershave and some medication may cause severe finish damage if not cleaned immediately.
- Keep instruction for future use.
- Do not place furniture directly under windows.
- Due to the presence of small parts during assembly, keep out of reach of children until assembly is complete.

- Evite poner cuchillos, tenedores y otros objetos afilados directamente sobre sus muebles, ya que podrían rayar y dañar el acabado.
- Para limpiar sus muebles, use un paño absorbente que sea suave, seco y sin pelusa. Evite el uso de detergentes, ya que podrían incluir sustancias que reaccionen y dañen el acabado.
- Limpie los derrames rápidamente. El agua que queda durante un período prolongado de tiempo puede causar daños. El alcohol, el perfume, los esmaltes de uñas, la loción para después del afeitado y algunos medicamentos pueden causar daños graves en el acabado si no se limpian inmediatamente.
- Conserve las instrucciones para una utilización posterior.
- No coloque los muebles directamente debajo de las ventanas.
- Debido a la presencia de piezas pequeñas durante el montaje, manténgalas fuera del alcance de los niños hasta que se complete el montaje.

WARNING / ADVERTENCIA

- Please use your furniture correctly and safely. Improper use can cause safety hazard, or damage to your furniture or household items.
- Serious or fatal crushing injuries can occur from furniture tip-over.
- To help prevent tip-over :
 - Place heaviest items in the lowest drawers or shelf.
 - Never allow children to climb or hang on drawer, shelf or doors.
 - Always monitor your child's activity when in the nursery.
 - Do not allow standing in drawer or shelf.
 - Do not allow standing on top of this product.
 - To avoid head injury, do not allow children to play underneath open drawer.
 - Accessory items must be securely fastened to this product according to the instructions provided with those items.
 - Do not leave drawers open when not in use.

- Por favor, utilice sus muebles de forma correcta y segura. El uso inadecuado puede causar peligro para la seguridad o daños a sus muebles o artículos del hogar.
- Pueden producirse lesiones graves o mortales por aplastamiento por el vuelco de los muebles.
- Para ayudar a prevenir el vuelco:
 - Coloque los artículos más pesados en los cajones o estantes más bajos.
 - Nunca permita que los niños trepen o se cuelguen de los cajones, estantes o puertas.
 - Vigile siempre la actividad de su hijo cuando esté en la guardería.
 - No permita que se queden de pie en el cajón o la estantería.
 - No permita que se pongan de pie encima de este producto.
 - Para evitar lesiones en la cabeza, no permita que los niños jueguen debajo del cajón abierto.
 - Los accesorios deben fijarse firmemente a este producto de acuerdo con las instrucciones suministradas con los mismos.
 - No deje los cajones abiertos cuando no se utilicen.

MINIFIX CAM & MINIFIX BOLT / CÀMARA MINIFIX & PERNO MINIFIX

MINIFIX BOLT
PERNO MINIFIX

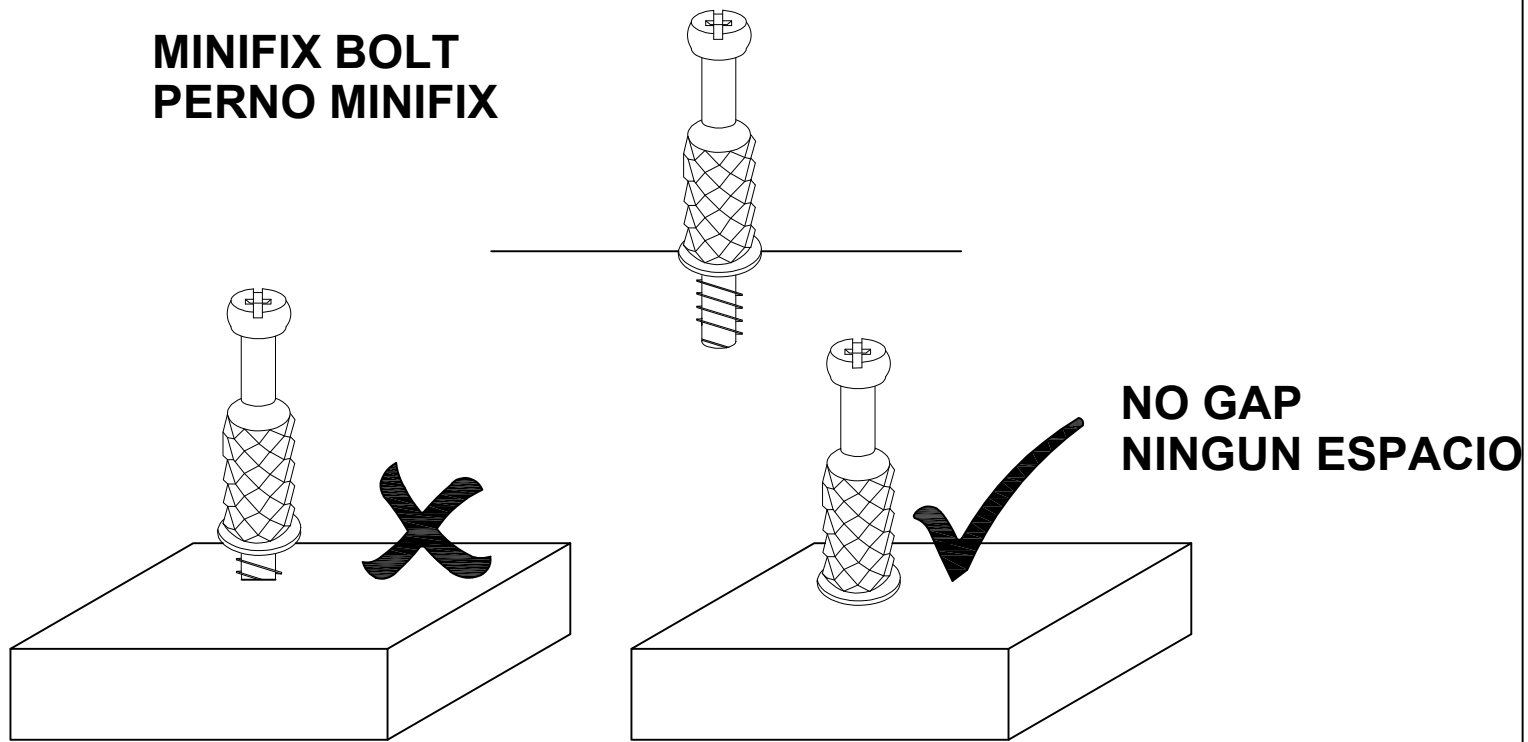

MINIFIX CAM
CÀMARA MINIFIX

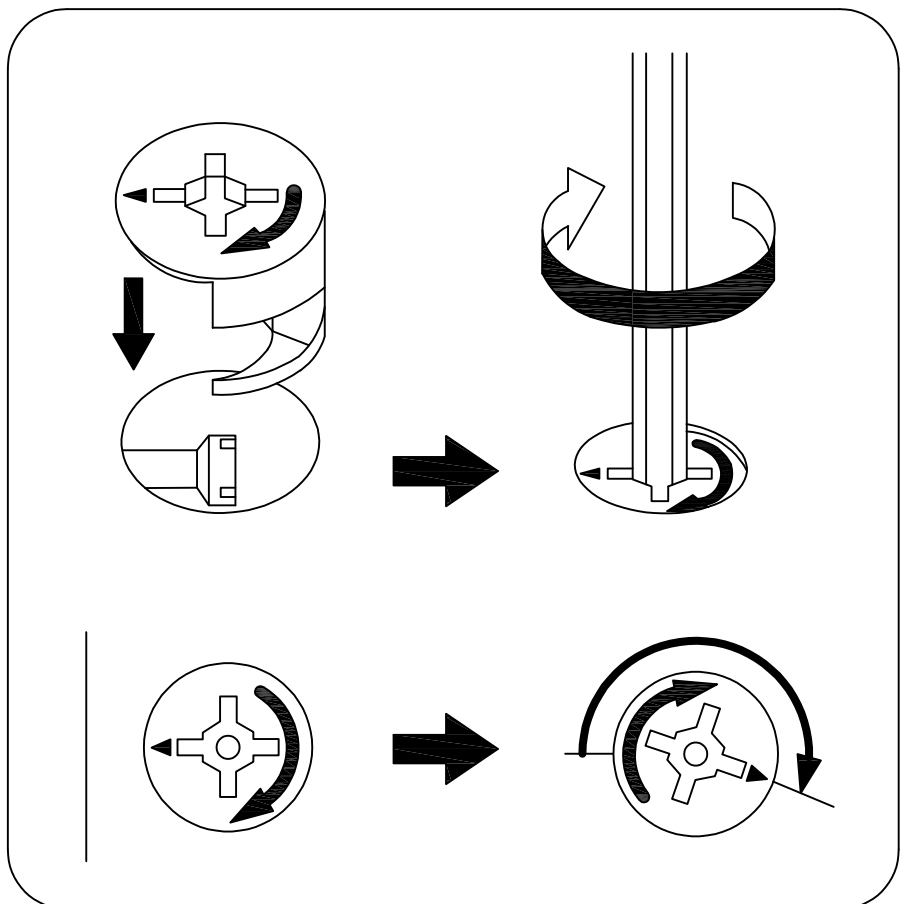
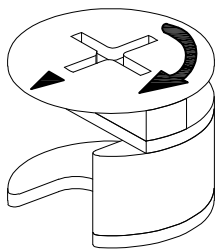

WOOD DOWEL / TACO DE MADERA

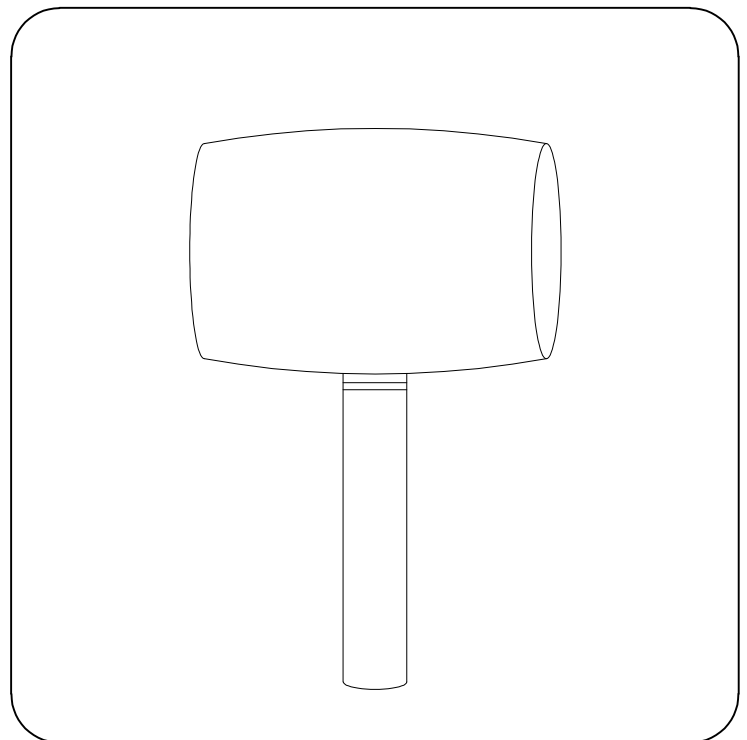
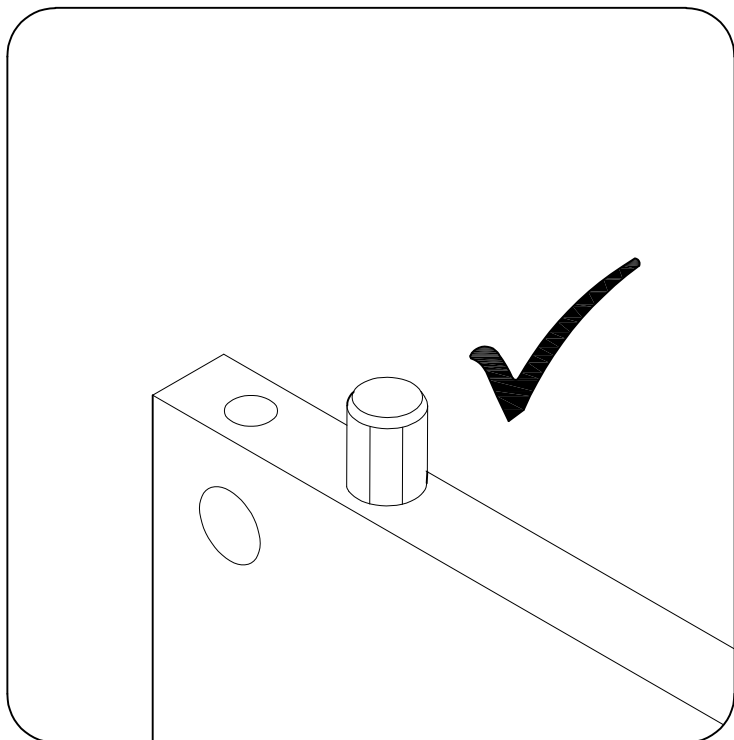
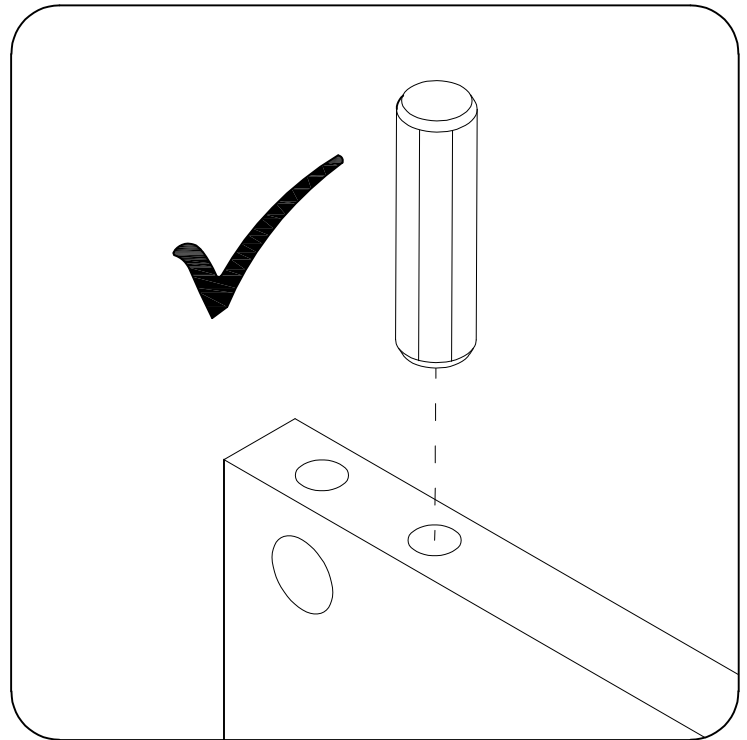
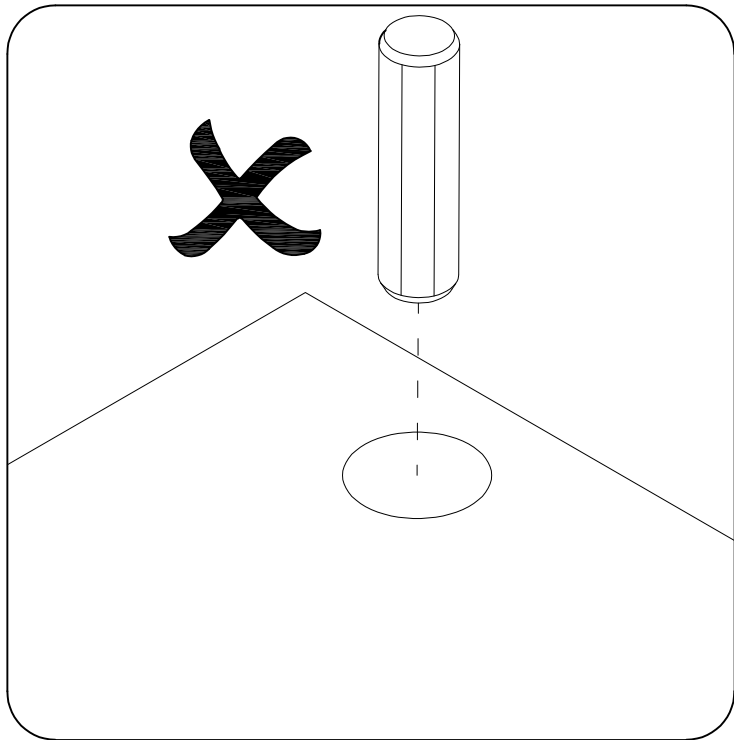

HOW TO REMOVE DRAWER SLIDES / CÓMO QUITAR LAS GUÍAS DE LOS CAJONES

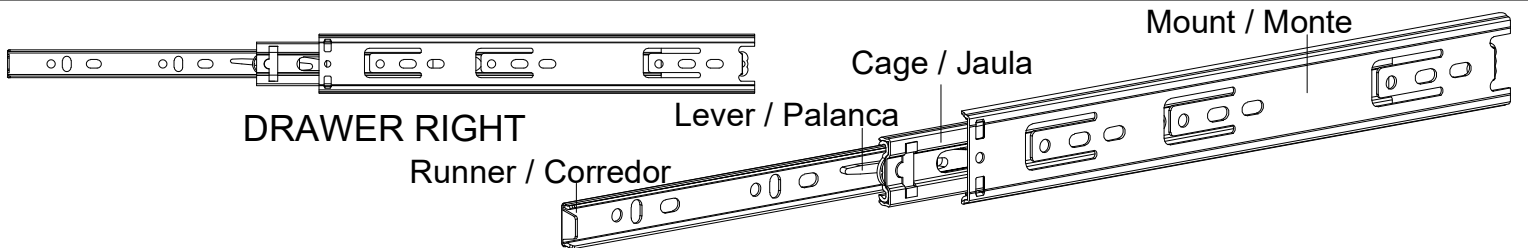
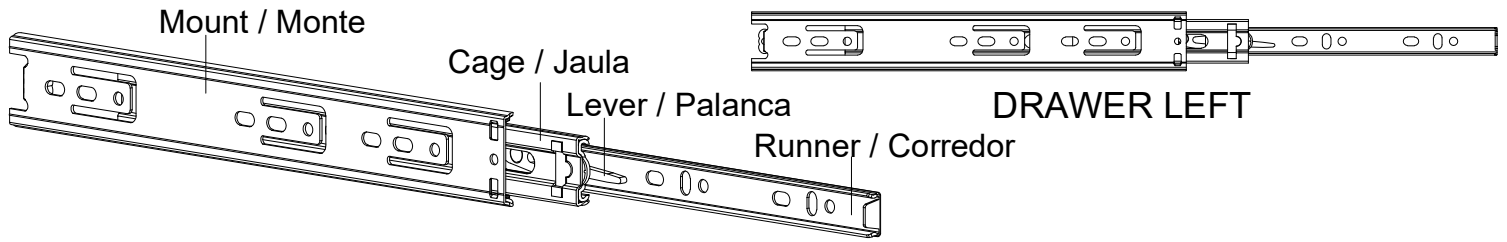

STEP 1 - Extend slide (L)
Extender corredera (L)

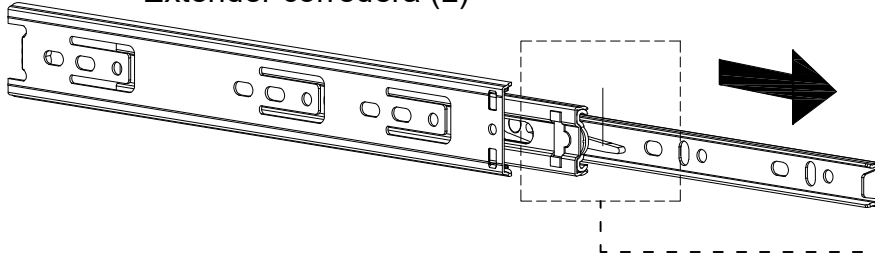

STEP 2 - Push lever (L)
Palanca de empuje (L)

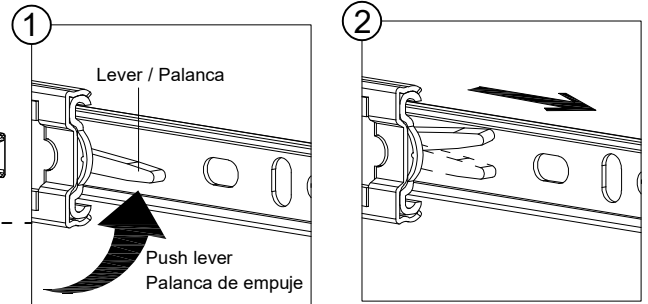

STEP 2 - Push lever (R)
Palanca de empuje (R)

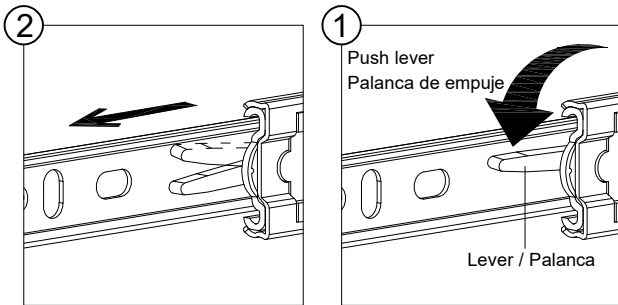

STEP 1 - Extend slide (R)
Extender corredera (R)

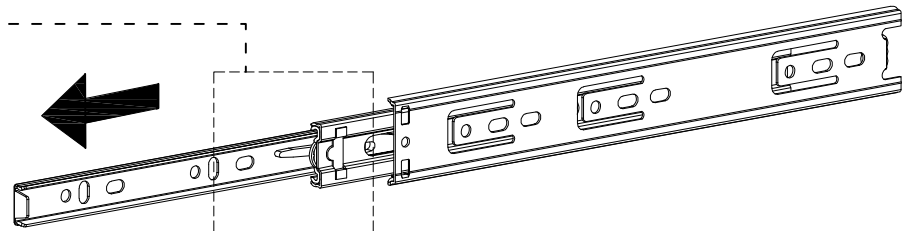

STEP 3 - Remove runner / Quitar corredor

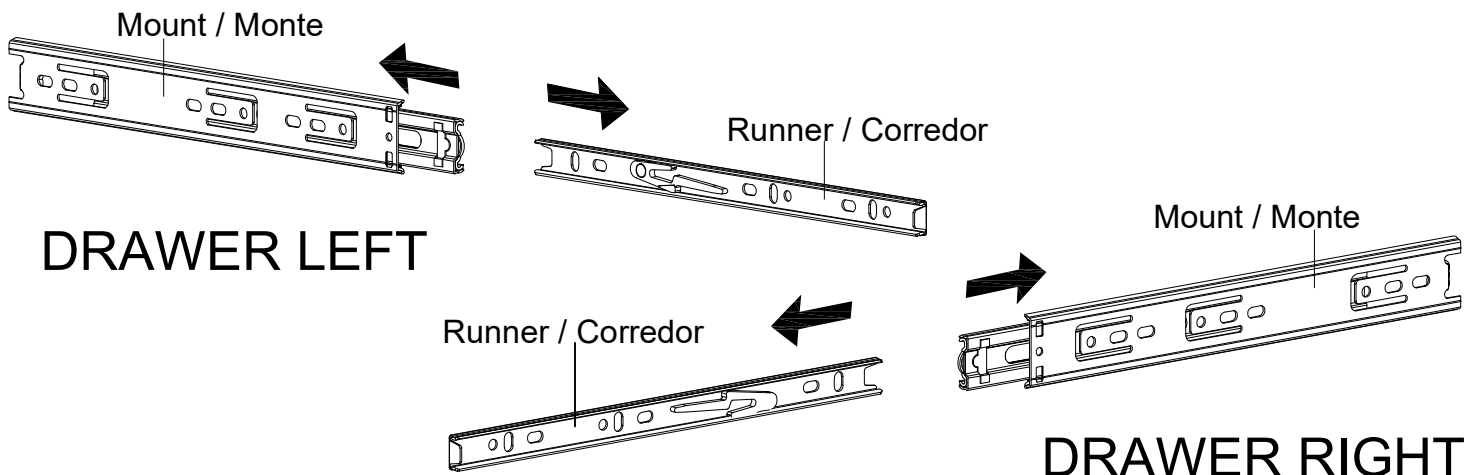

PARTLIST / LISTA DE PIEZAS

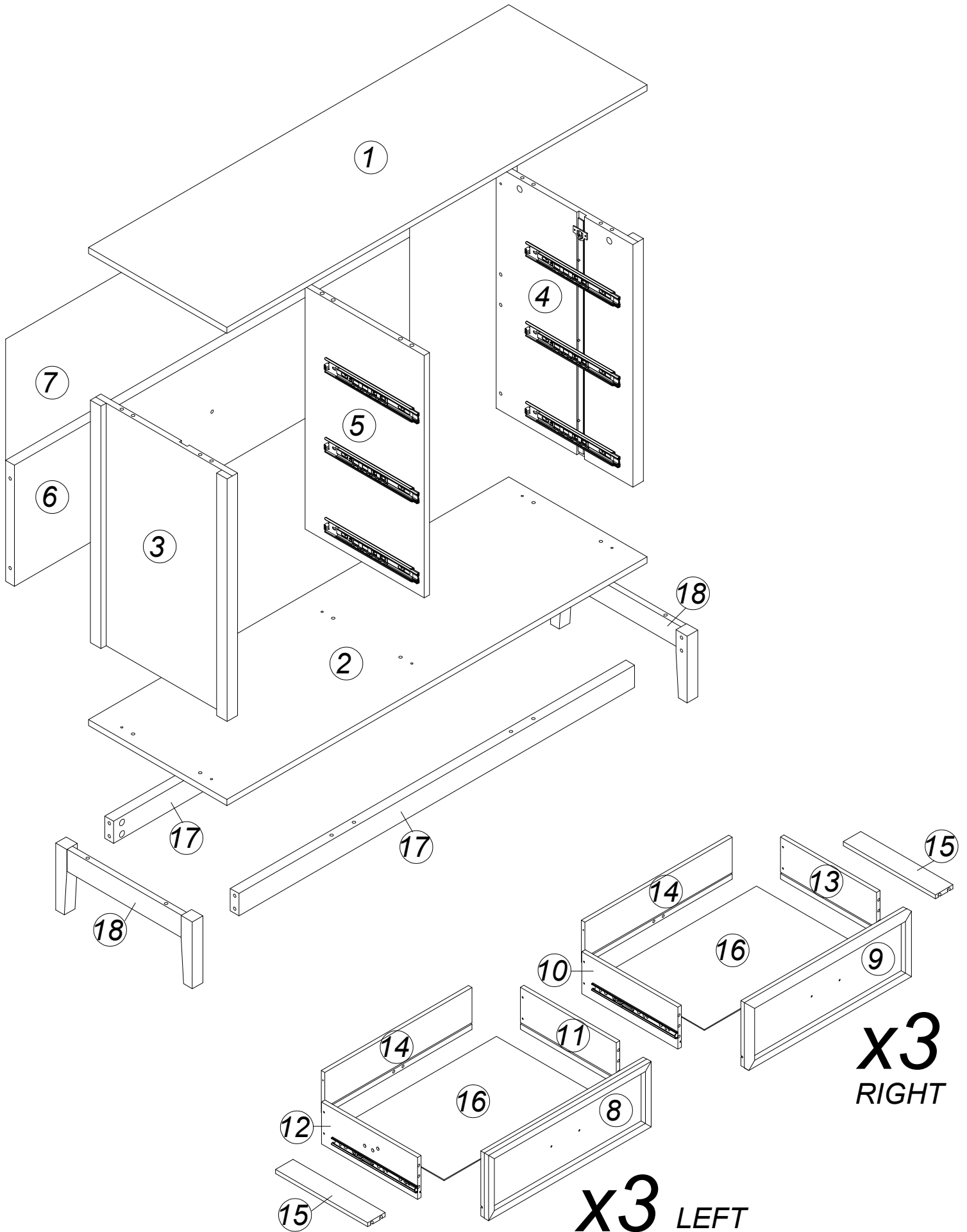

PARTLIST / LISTA DE PIEZAS

1 TOP PANEL

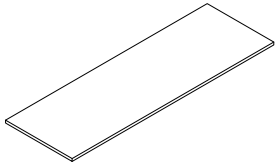

1 PCS

2 BOTTOM PANEL

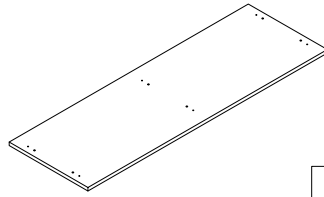

1 PCS

3 SIDE PANEL - LEFT

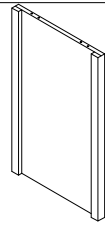

1 PCS

4 SIDE PANEL - RIGHT

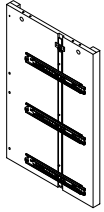

1 PCS

5 SIDE PANEL - CENTER



1 PCS

6 BACK SUPPORT

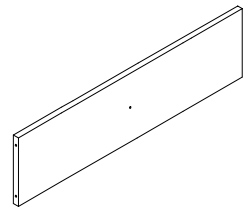

1 PCS

7 BACK COVER

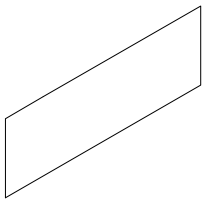

1 PCS

8 DRAWER FACE - LEFT

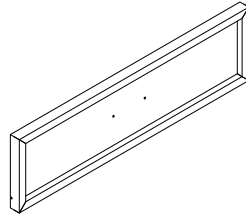

3 PCS

9 DRAWER FACE - RIGHT

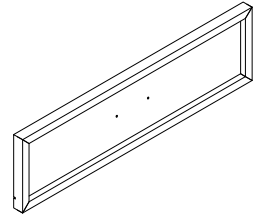

3 PCS

10 DRAWER SIDE - LEFT

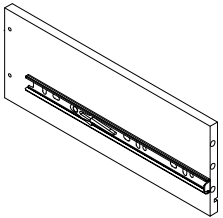

3 PCS

11 DRAWER SIDE - RIGHT

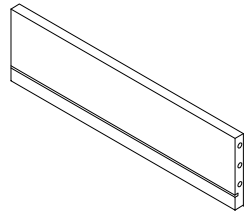

3 PCS

12 DRAWER LEFT STOPPER

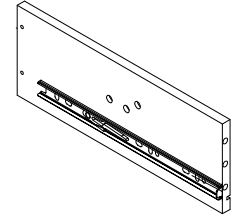

3 PCS

13 DRAWER RIGHT STOPPER

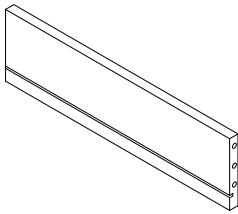

3 PCS

14 DRAWER BACK

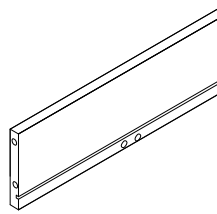

6 PCS

15 DRAWER SUPPORT

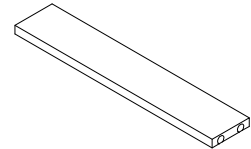

6 PCS

16 DRAWER BOTTOM

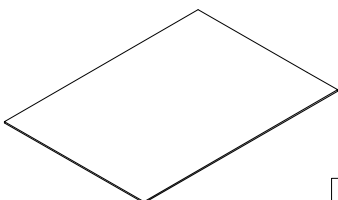

6 PCS

17 DOWN SUPPORT FRONT/BACK

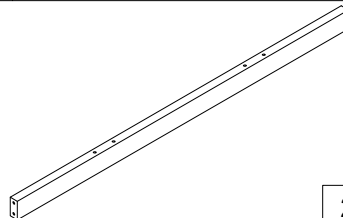

2 PCS

18 LEG

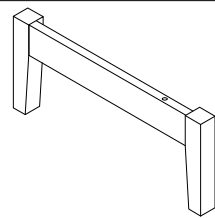

2 PCS

HARDWARE / HERRAJE

(A) MINIFIX 16MM



18 UNITS

(B) MINICAM 16MM



18 UNITS

(C) ALLEN KEY



1 UNITS

(D) DOWEL 8 X 30MM

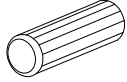

16 UNITS

(E) CP 2X15X30

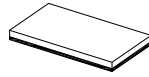

4 UNITS

(F) HANDLE HB107-GOLD
(96MM)

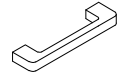

6 UNITS

(G) HANDLE SCREW
M4 X 18MM

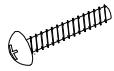

12 UNITS

(H) STOPPER RIGHT



3 UNITS

(I) STOPPER LEFT



3 UNITS

(J) PAN HEAD
M3.5 X 16MM

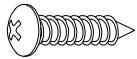

18 UNITS

(K) MINIFIX (12MM)



12 UNITS

(L) MINICAM (12MM)



12 UNITS

(M) DOWEL 6 X 30MM

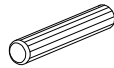

48 UNITS

(N) CSK M4 X 32MM

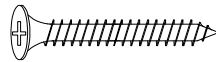

24 UNITS

(O) SCREW #10 X 2 1/2

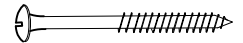

8 UNITS

(P) CAP WOOD SCREW
M6 X 50 MM



7 UNITS

(Q) NAIL

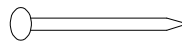

14 UNITS

(R) METAL LEG
MIDDLE SUPPORT WHITE

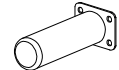

1 UNITS

(S) PAN HEAD 10 X 1/2

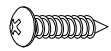

4 UNITS

INSTALLATION PRECAUTIONS / PRECAUCIONES DE INSTALACIÓN

- "To ensure the durability and stability of our furniture, we have chosen not to pre-drill holes for certain screws. Instead, we have marked the positions where screws should be installed, ensuring a secure and tight fit that meets your specific needs."
- "If we pre-drill the specific hole before inserting the certain screw, the screw will not hold tightly. This is because the material that the screw needs to grip onto is removed during drilling, so it won't have enough resistance to stay secure."

ASSEMBLY INSTRUCTION / INSTRUCCIONES DE MONTAJE

STEP 1

D		DOWEL 8 X 30 MM	16 Pcs
---	---	-----------------	--------

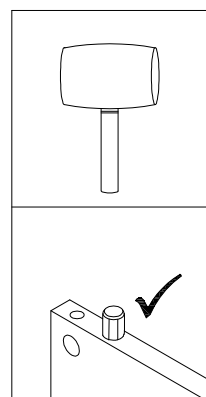
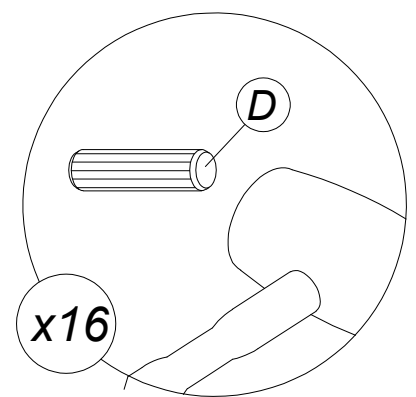
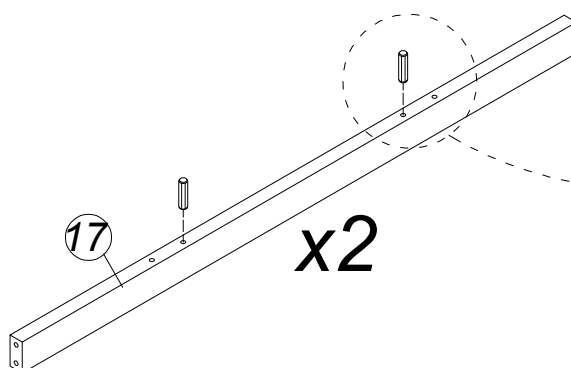
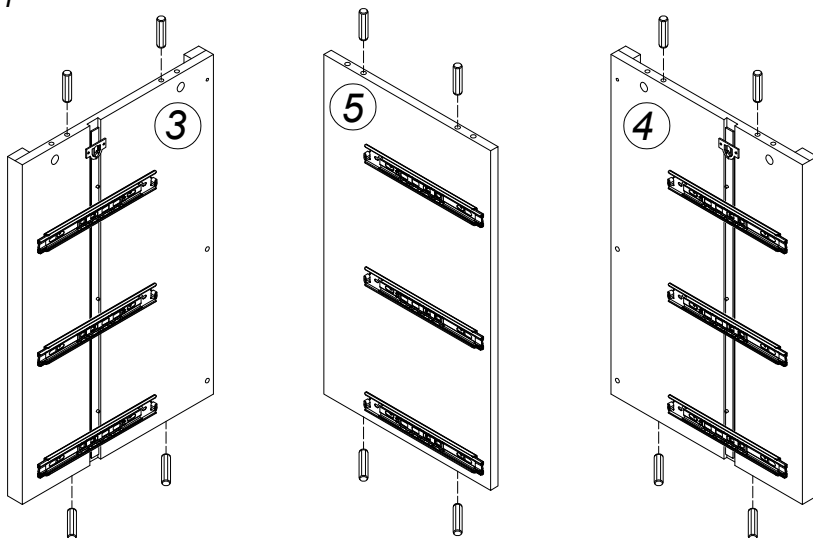

ASSEMBLY INSTRUCTION / INSTRUCCIONES DE MONTAJE

STEP 2

A		MINIFIX 16MM	18 Pcs
---	---	--------------	--------

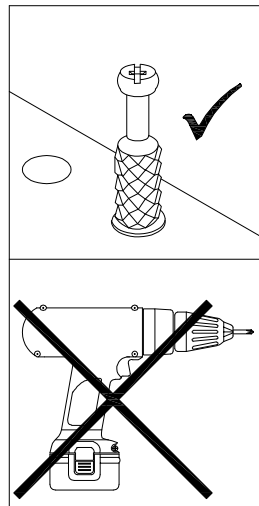
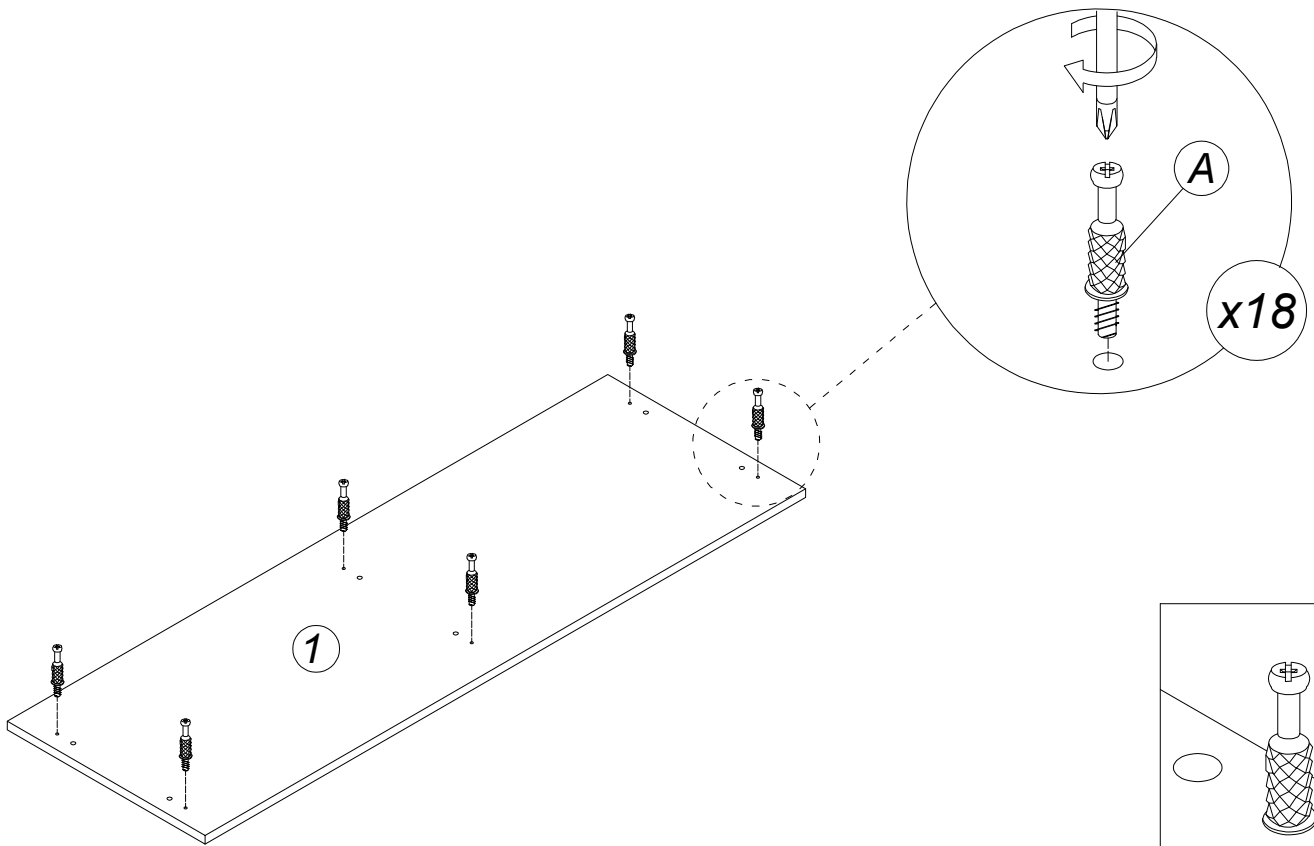
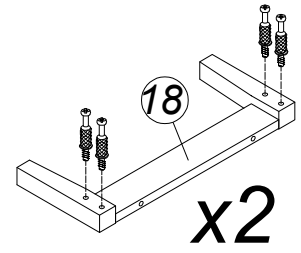
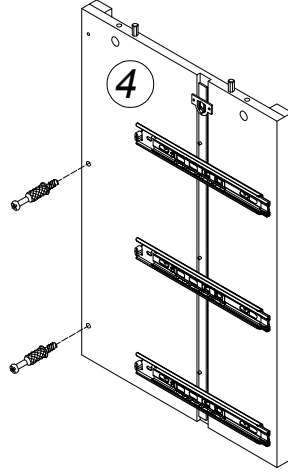
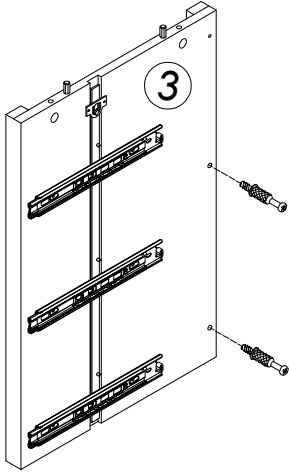

ASSEMBLY INSTRUCTION / INSTRUCCIONES DE MONTAJE

STEP 3

M		DOWEL 6 X 30 MM	48 Pcs
---	--	-----------------	--------

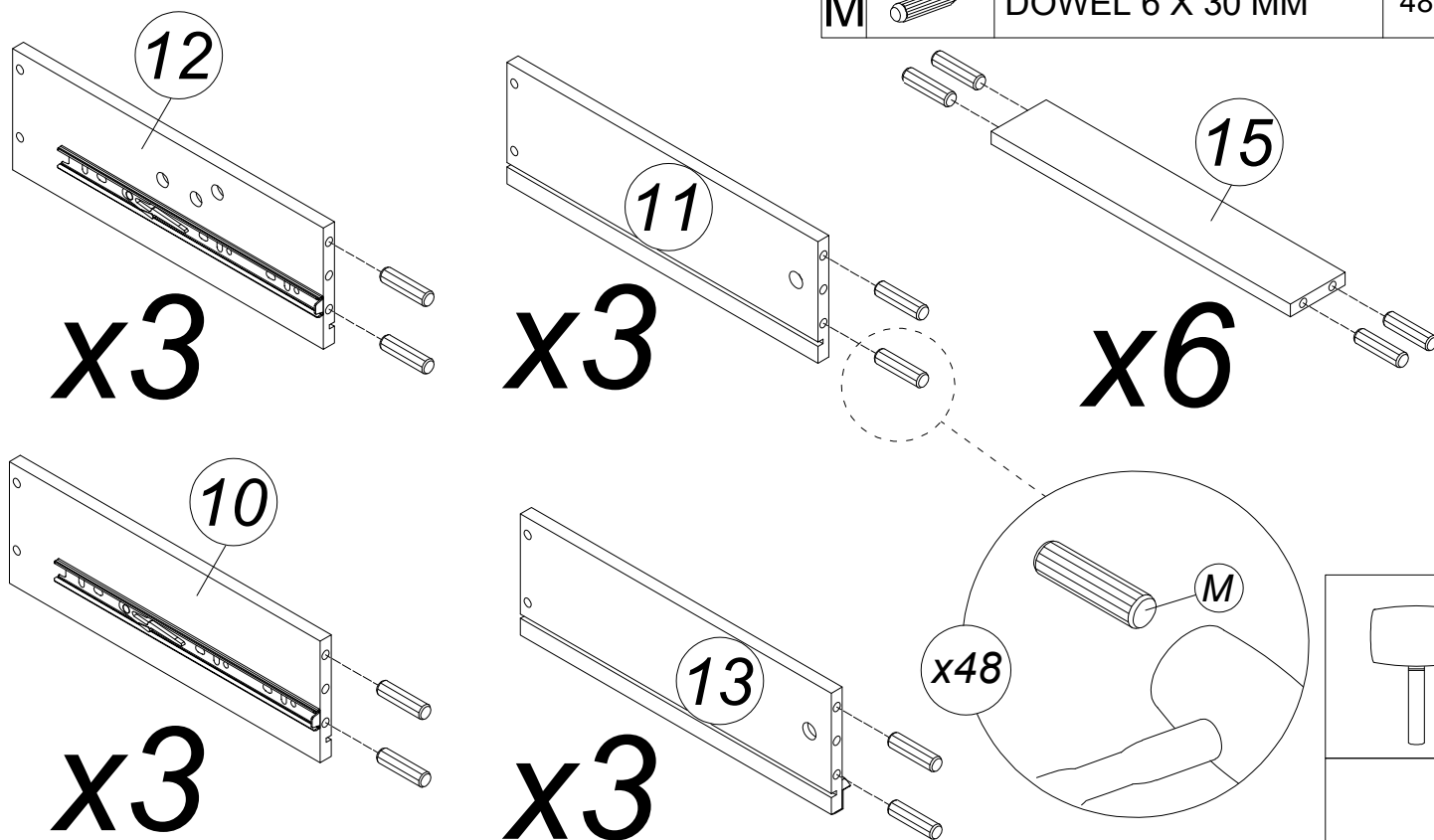

STEP 4

K		MINIFIX (12MM)	12 Pcs
---	--	----------------	--------

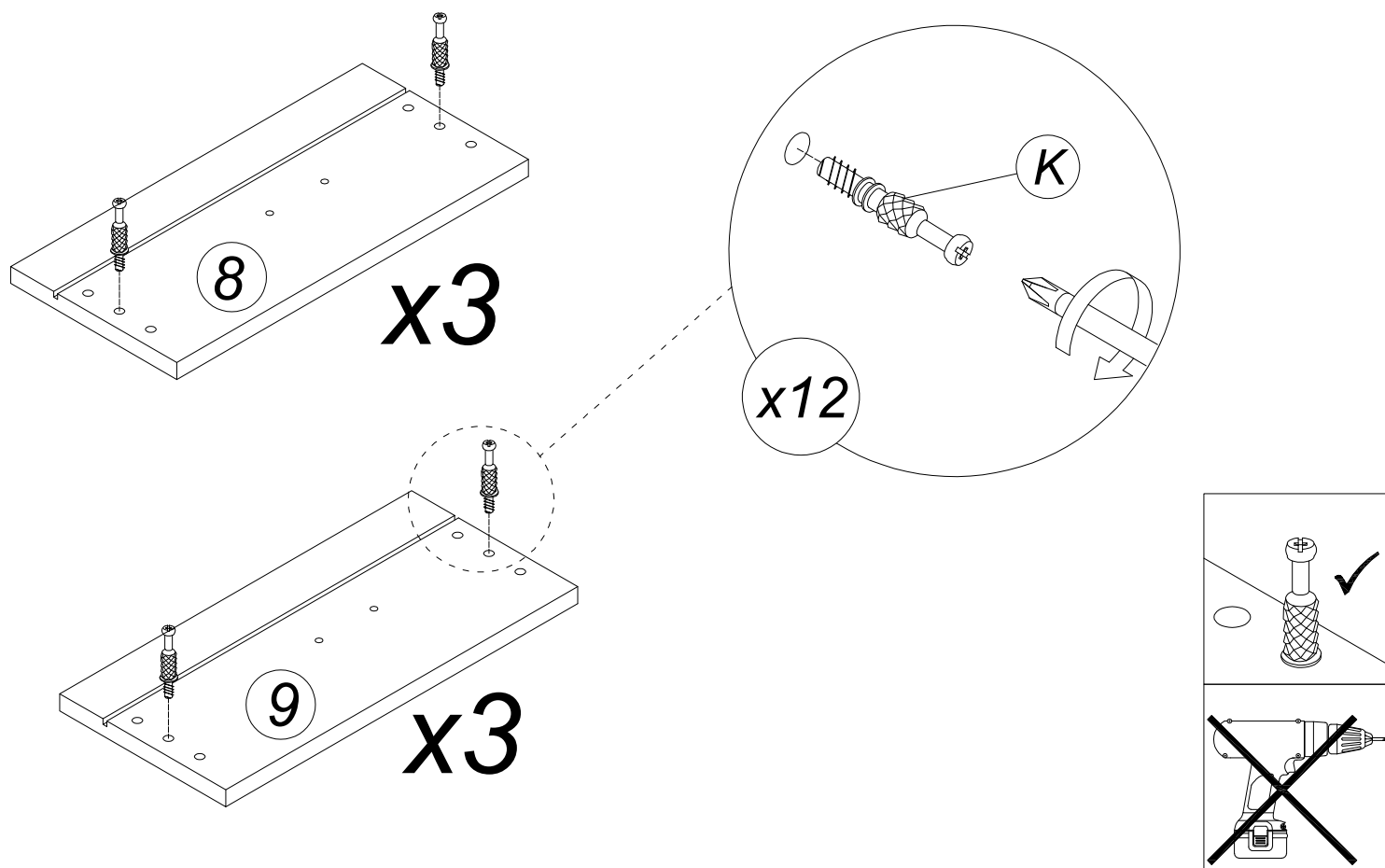

ASSEMBLY INSTRUCTION / INSTRUCCIONES DE MONTAJE

STEP 5

B		MINICAM 16MM	2 Pcs
----------	---	--------------	-------

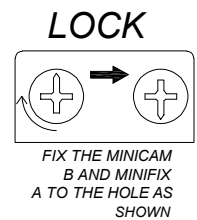
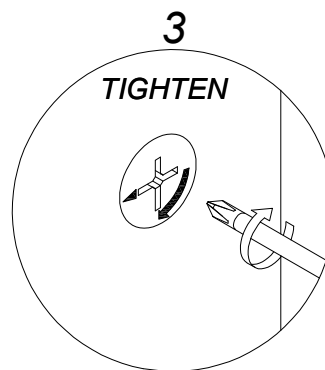
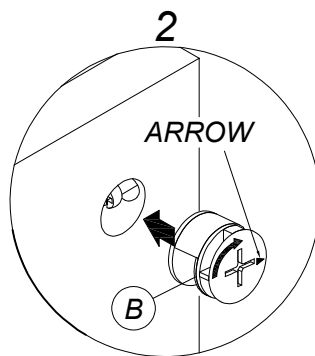
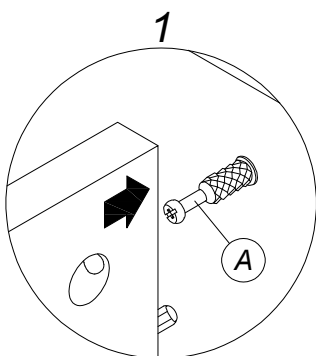
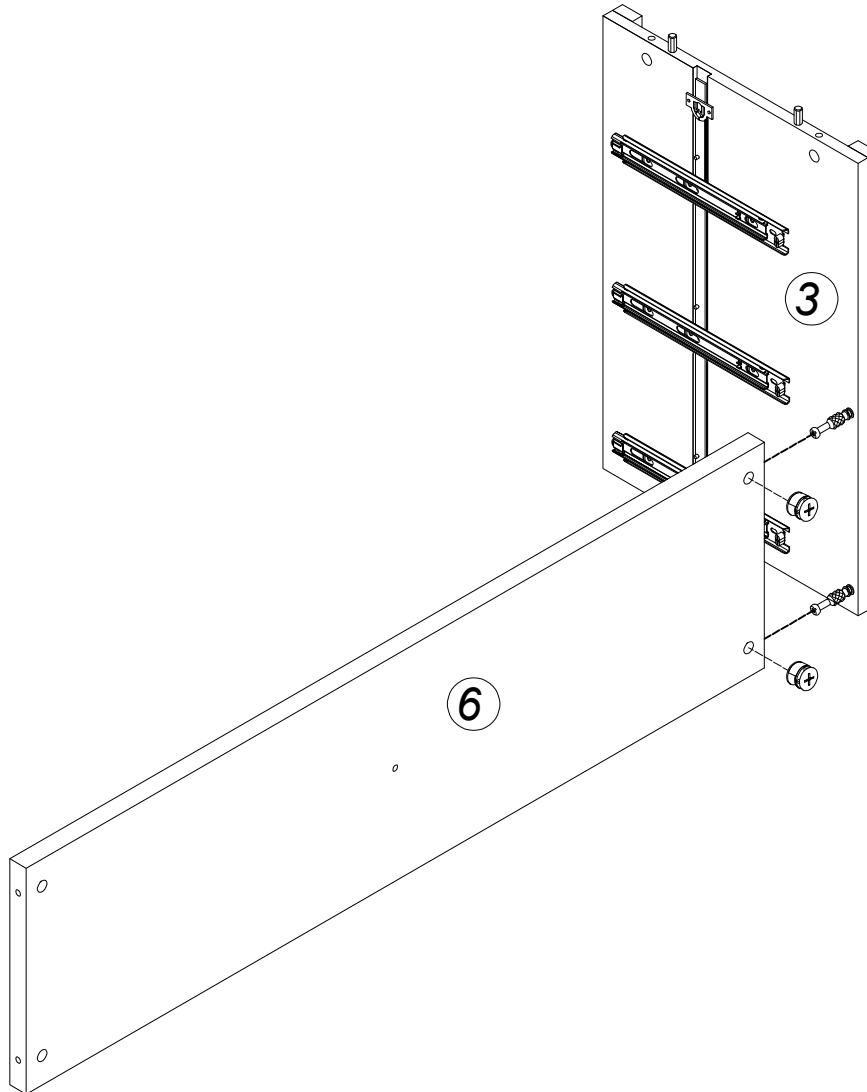

ASSEMBLY INSTRUCTION / INSTRUCCIONES DE MONTAJE

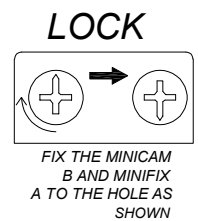
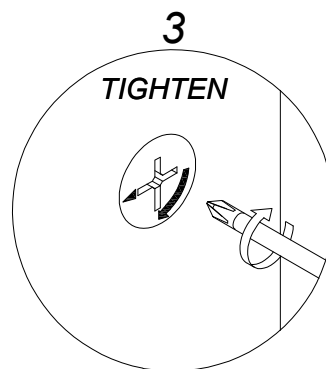
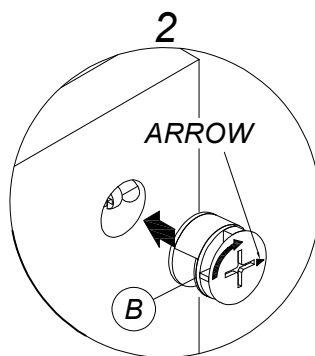
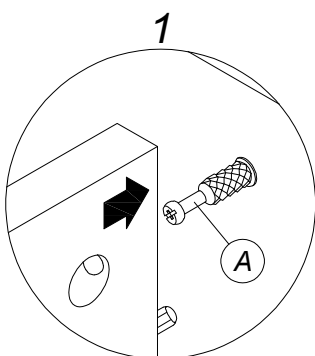
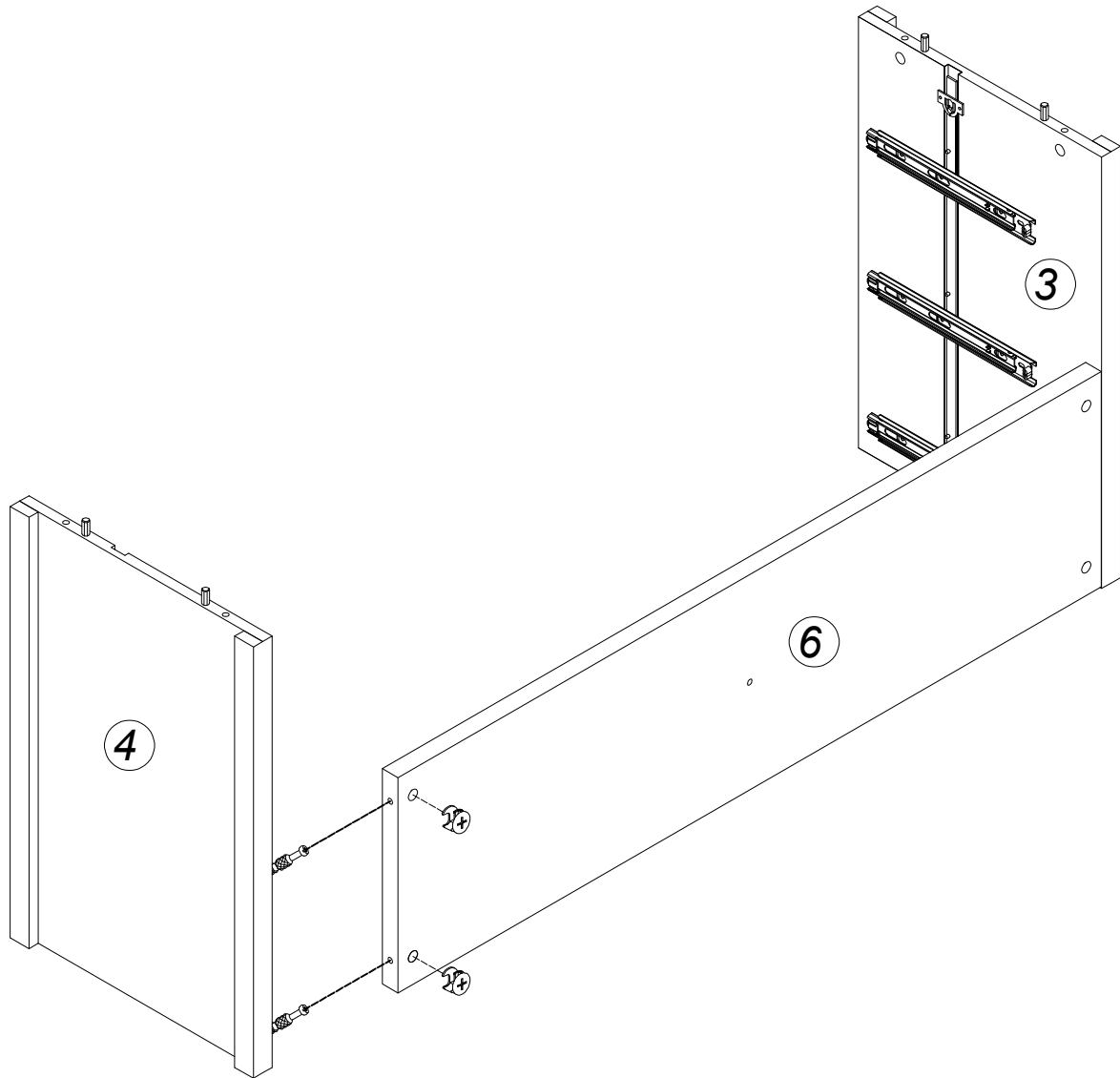

STEP 6

B		MINICAM 16MM	2 Pcs
----------	---	--------------	-------



ASSEMBLY INSTRUCTION / INSTRUCCIONES DE MONTAJE

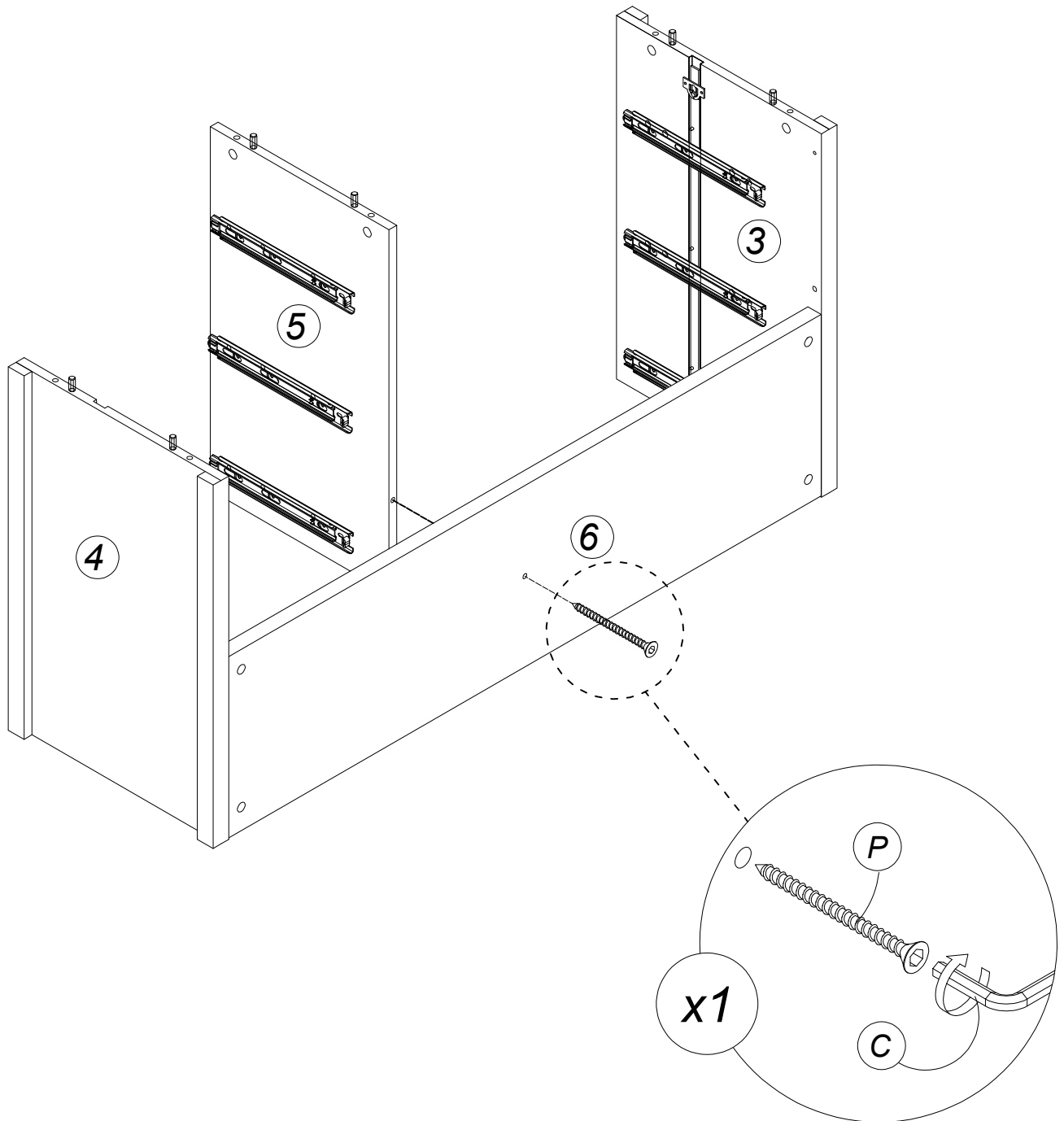

STEP 7

P		CAP WOOD SCREW M6 X 50 MM	1 Pcs
C		ALLEN KEY	1 Pcs



ASSEMBLY INSTRUCTION / INSTRUCCIONES DE MONTAJE

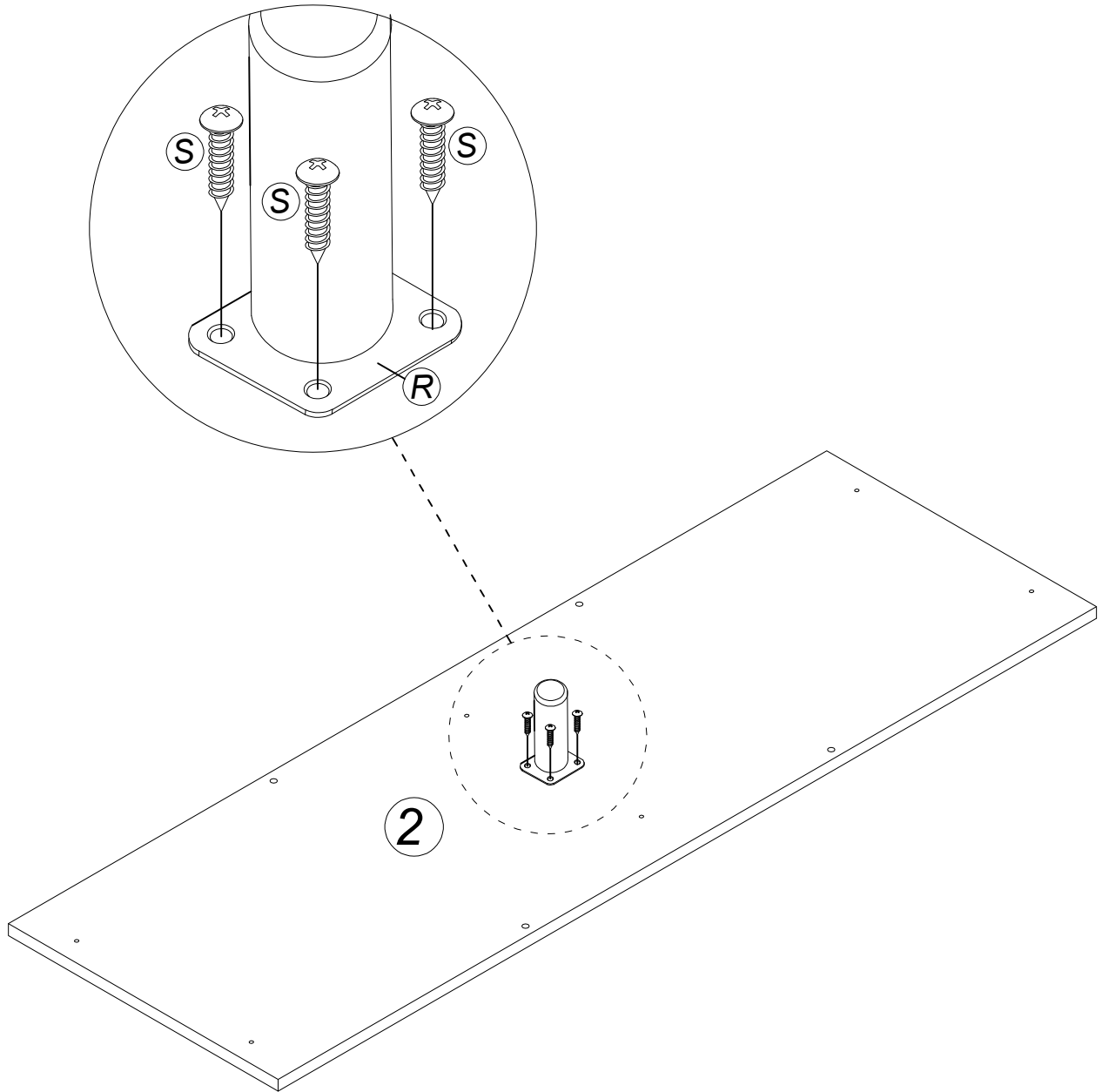

STEP 8

R		METAL LEG MIDDLE SUPPORT	1 Pcs
S		PAN HEAD 10 X 1/2	4 Pcs



ASSEMBLY INSTRUCTION / INSTRUCCIONES DE MONTAJE

STEP 9

P		CAP WOOD SCREW M6 X 50 MM	6 Pcs
C		ALLEN KEY	1 Pcs

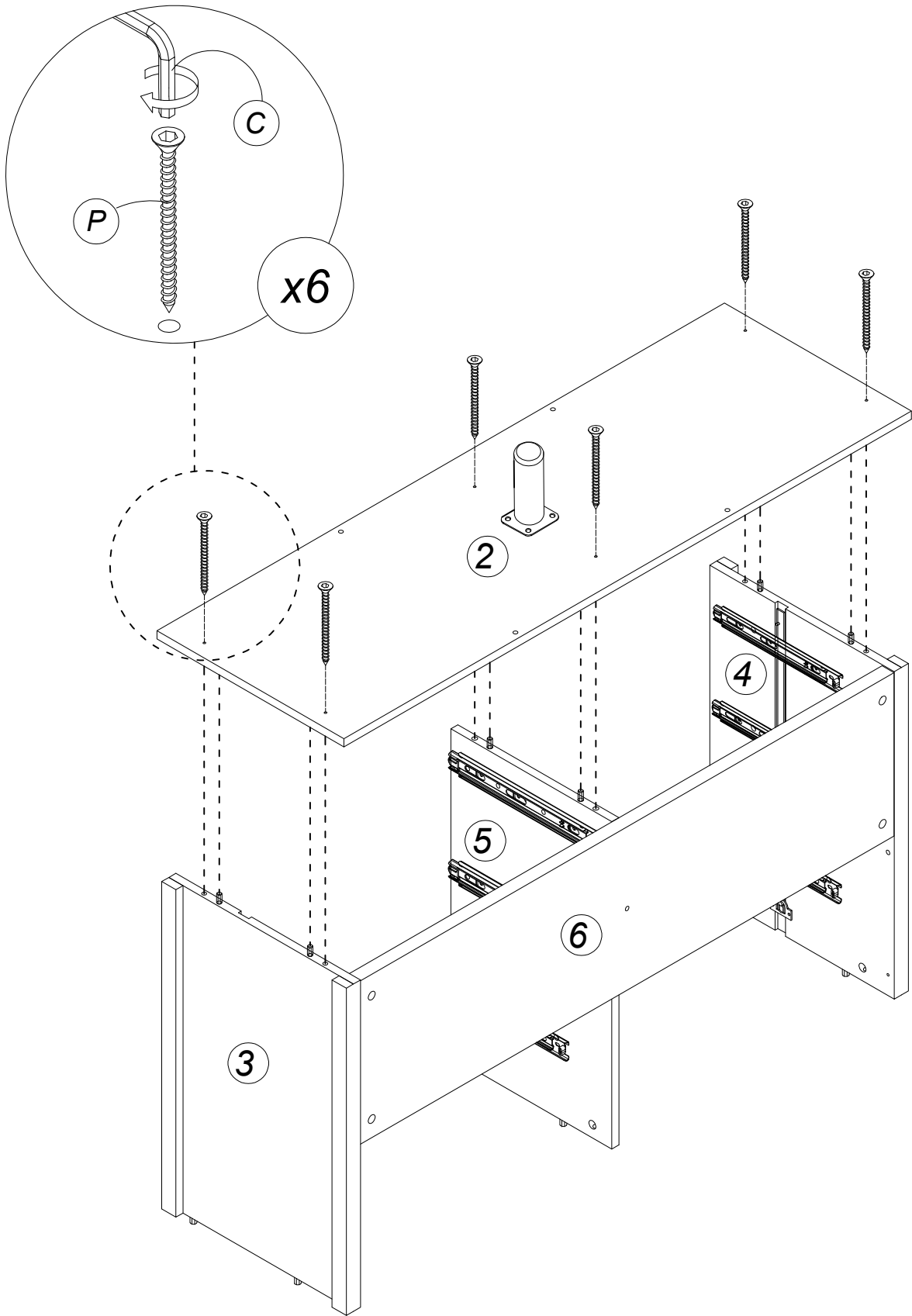

ASSEMBLY INSTRUCTION / INSTRUCCIONES DE MONTAJE

STEP 10

B		MINICAM 16MM	2 Pcs
---	---	--------------	-------

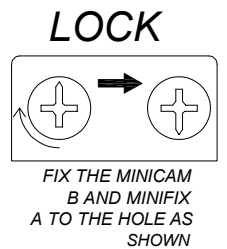
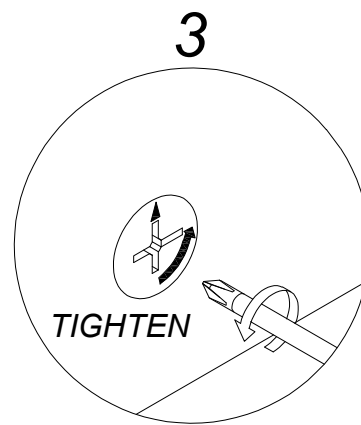
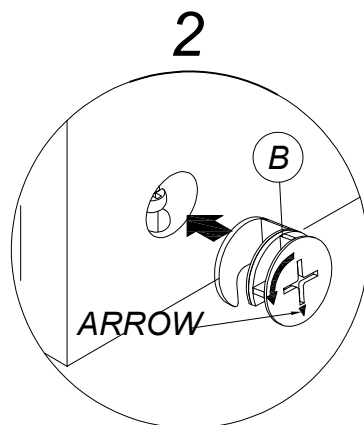
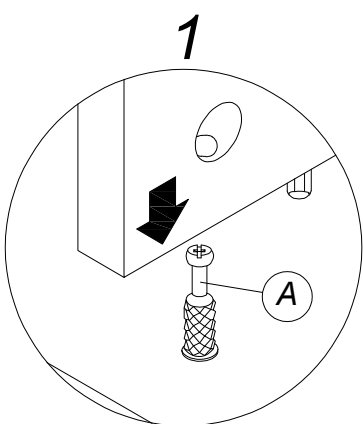
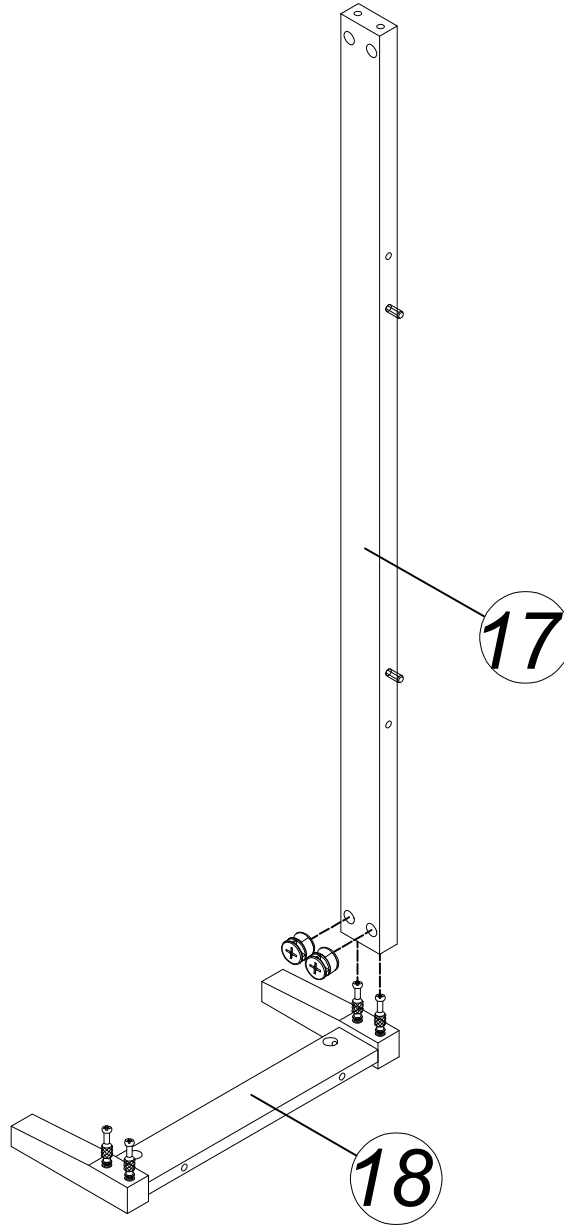

ASSEMBLY INSTRUCTION / INSTRUCCIONES DE MONTAJE

STEP 11

B		MINICAM 16MM	2 Pcs
---	---	--------------	-------

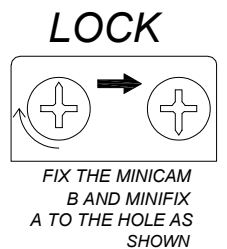
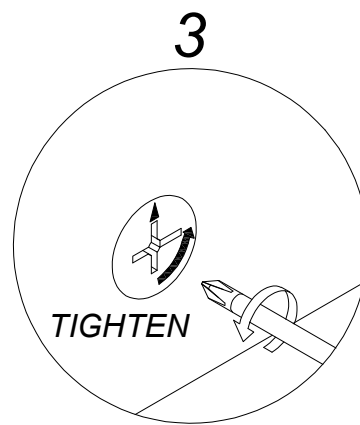
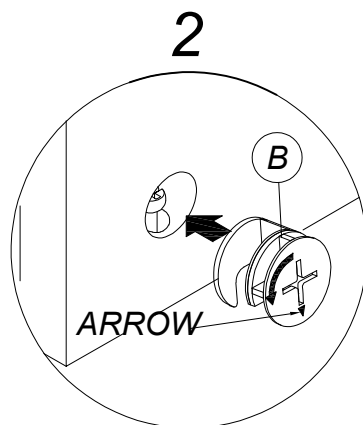
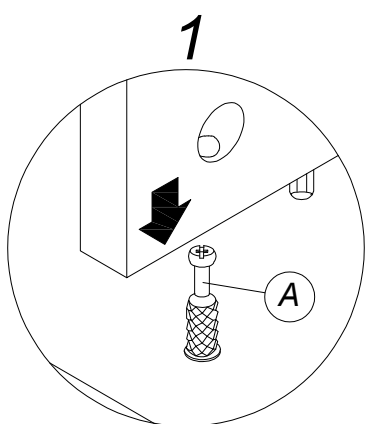
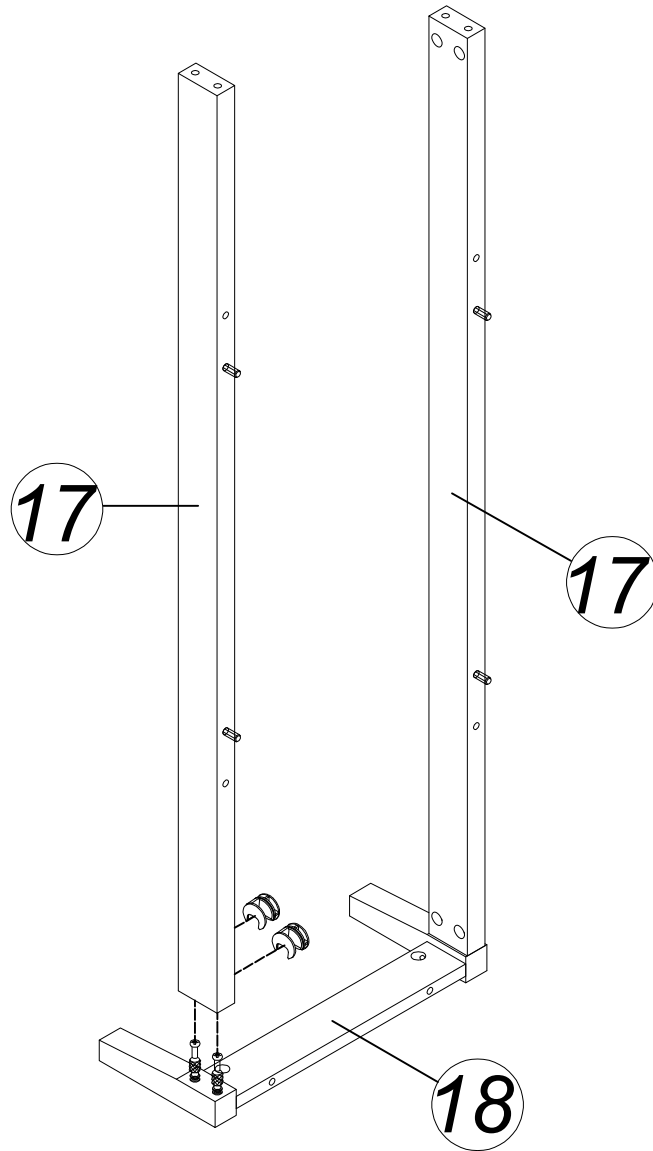

ASSEMBLY INSTRUCTION / INSTRUCCIONES DE MONTAJE

STEP 12

B		MINICAM 16MM	4 Pcs
---	---	--------------	-------

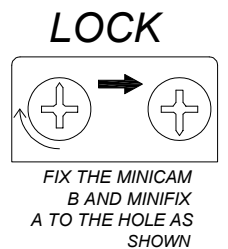
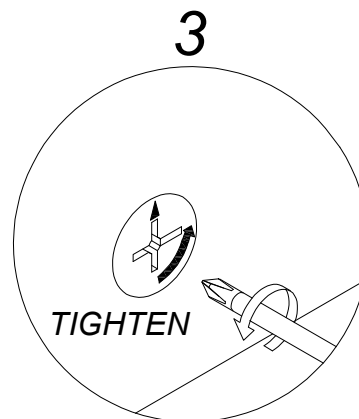
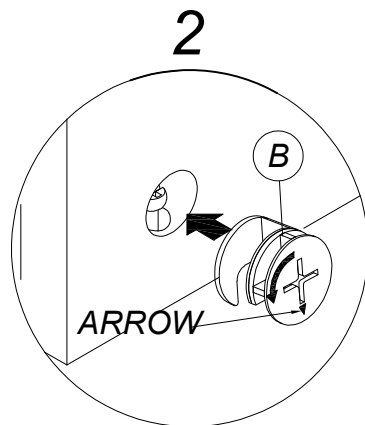
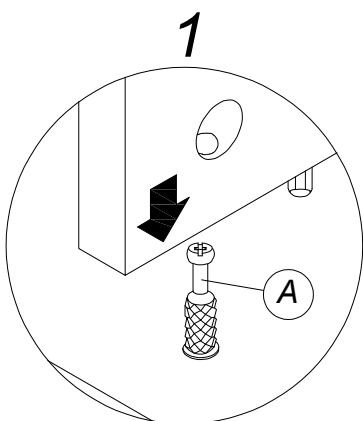
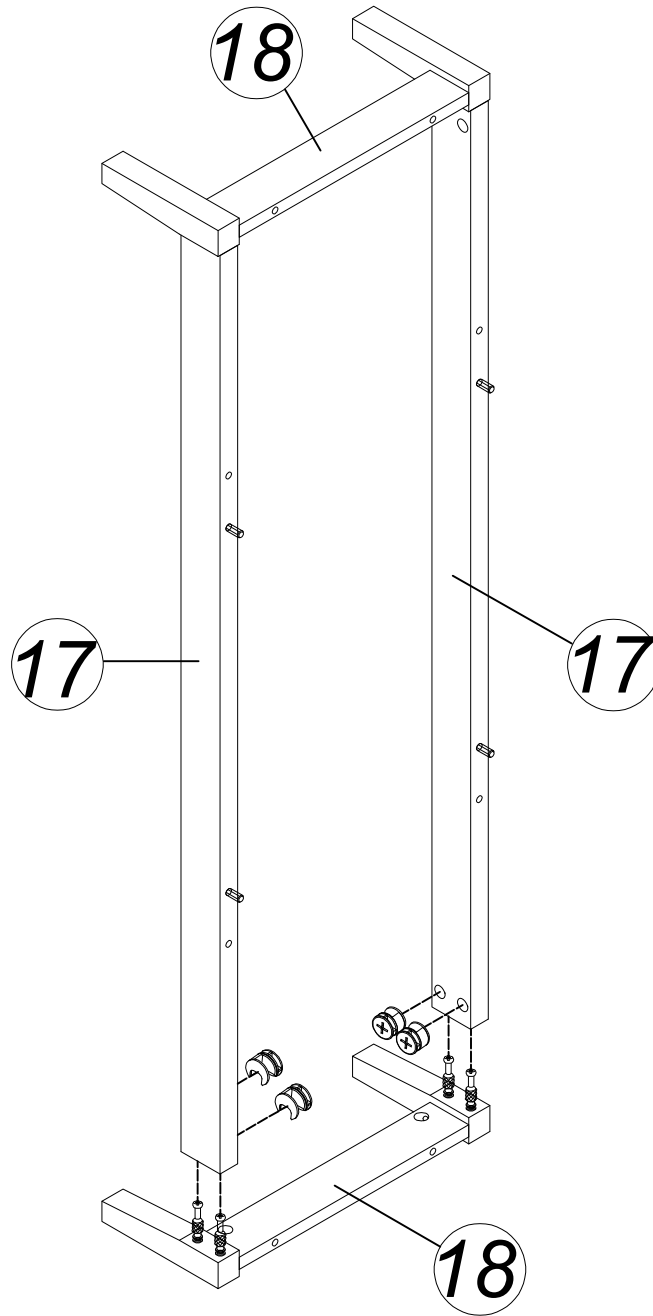

ASSEMBLY INSTRUCTION / INSTRUCCIONES DE MONTAJE

STEP 13

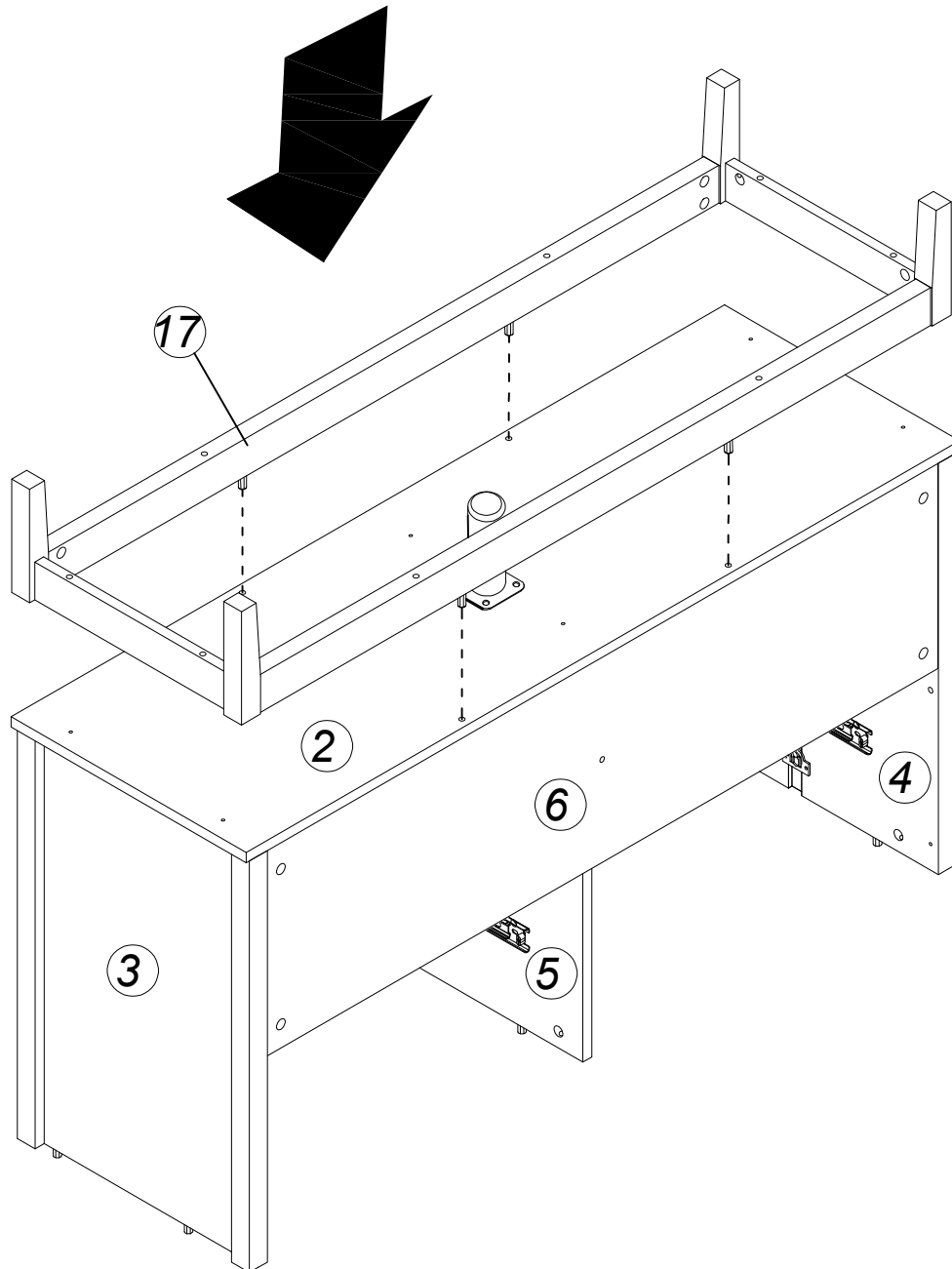

ASSEMBLY INSTRUCTION / INSTRUCCIONES DE MONTAJE

STEP 14

 SCREW - #10 X 2 1/2" 8 Pcs

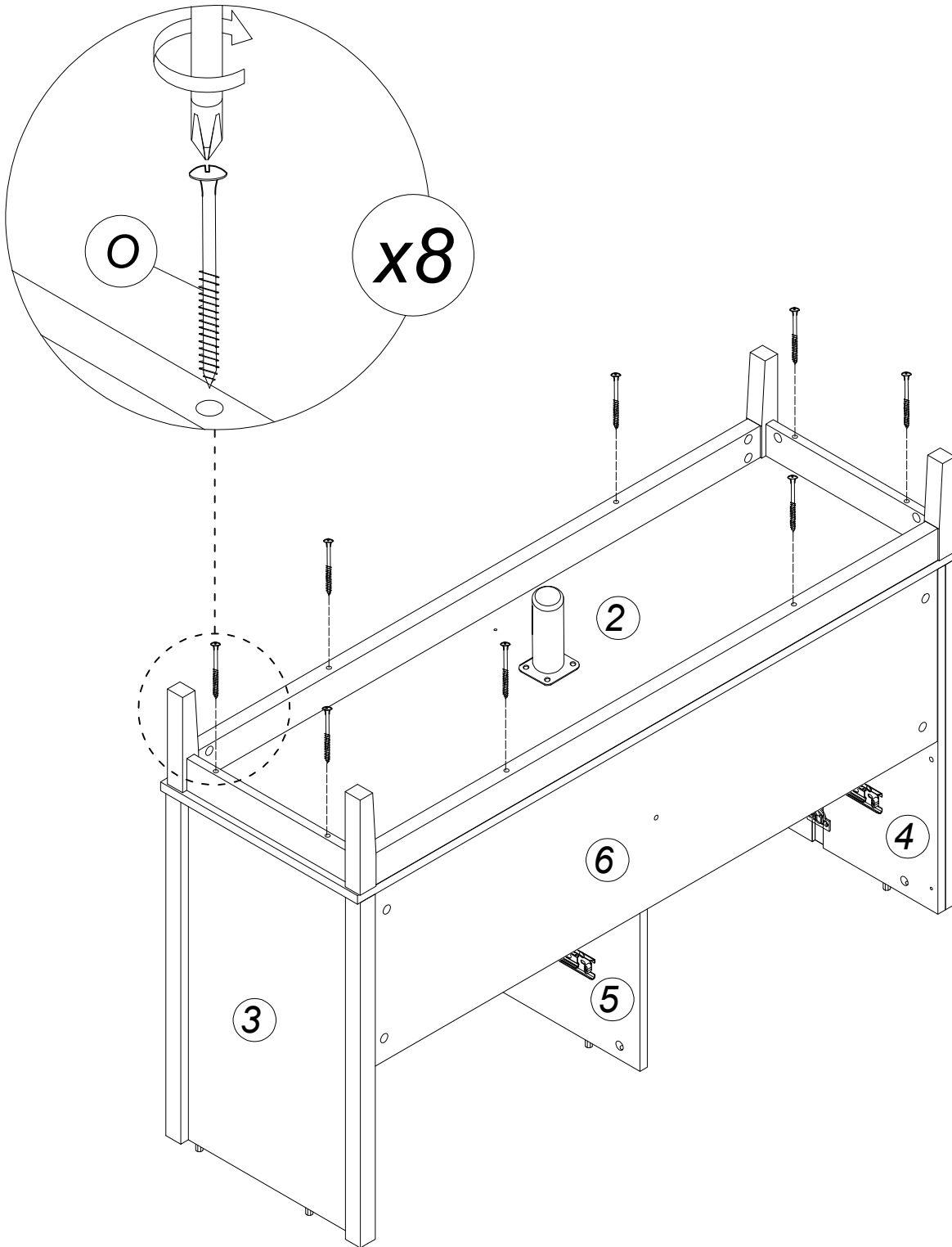

ASSEMBLY INSTRUCTION / INSTRUCCIONES DE MONTAJE

STEP 15

E		CP 2X15X30	4 Pcs
---	---	------------	-------

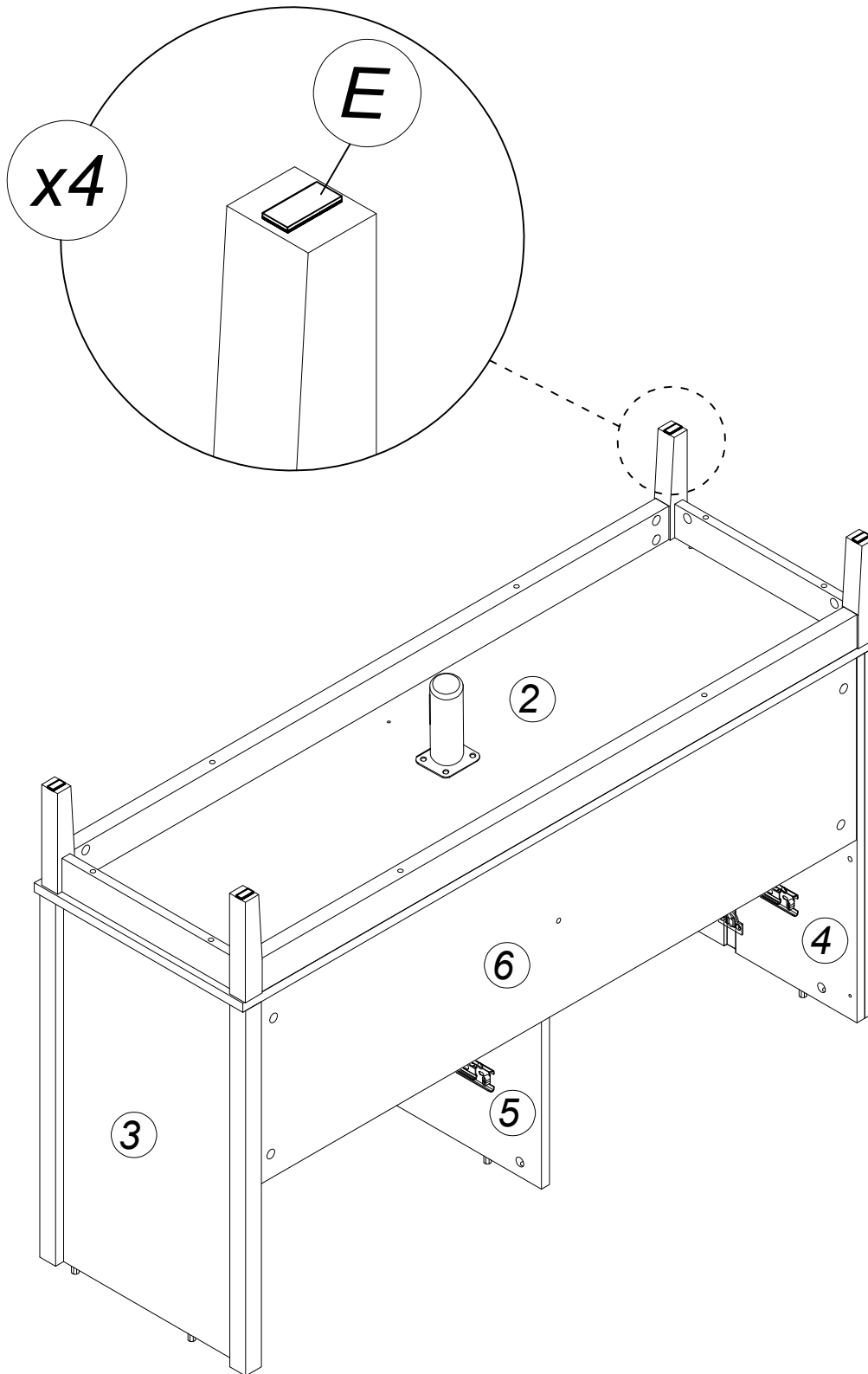

ASSEMBLY INSTRUCTION / INSTRUCCIONES DE MONTAJE

STEP 16

B



MINICAM 16MM

6 Pcs

!!! Carefully and slowly turn the unit over.
!!! Gire la unidad con cuidado y lentamente.

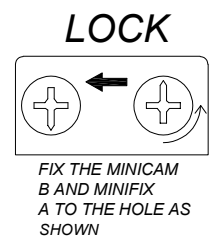
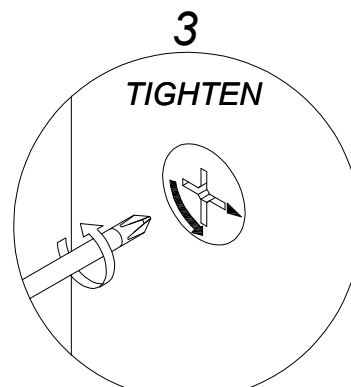
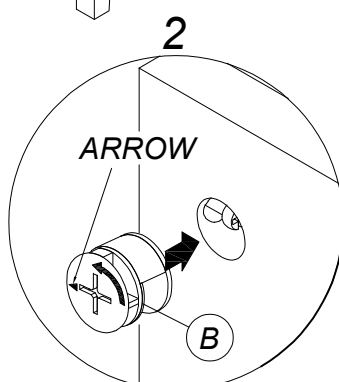
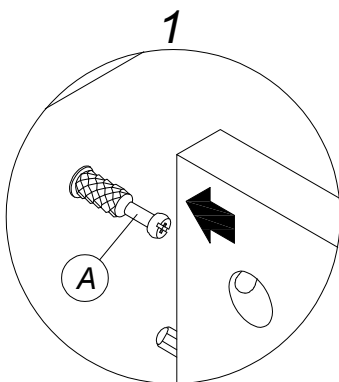
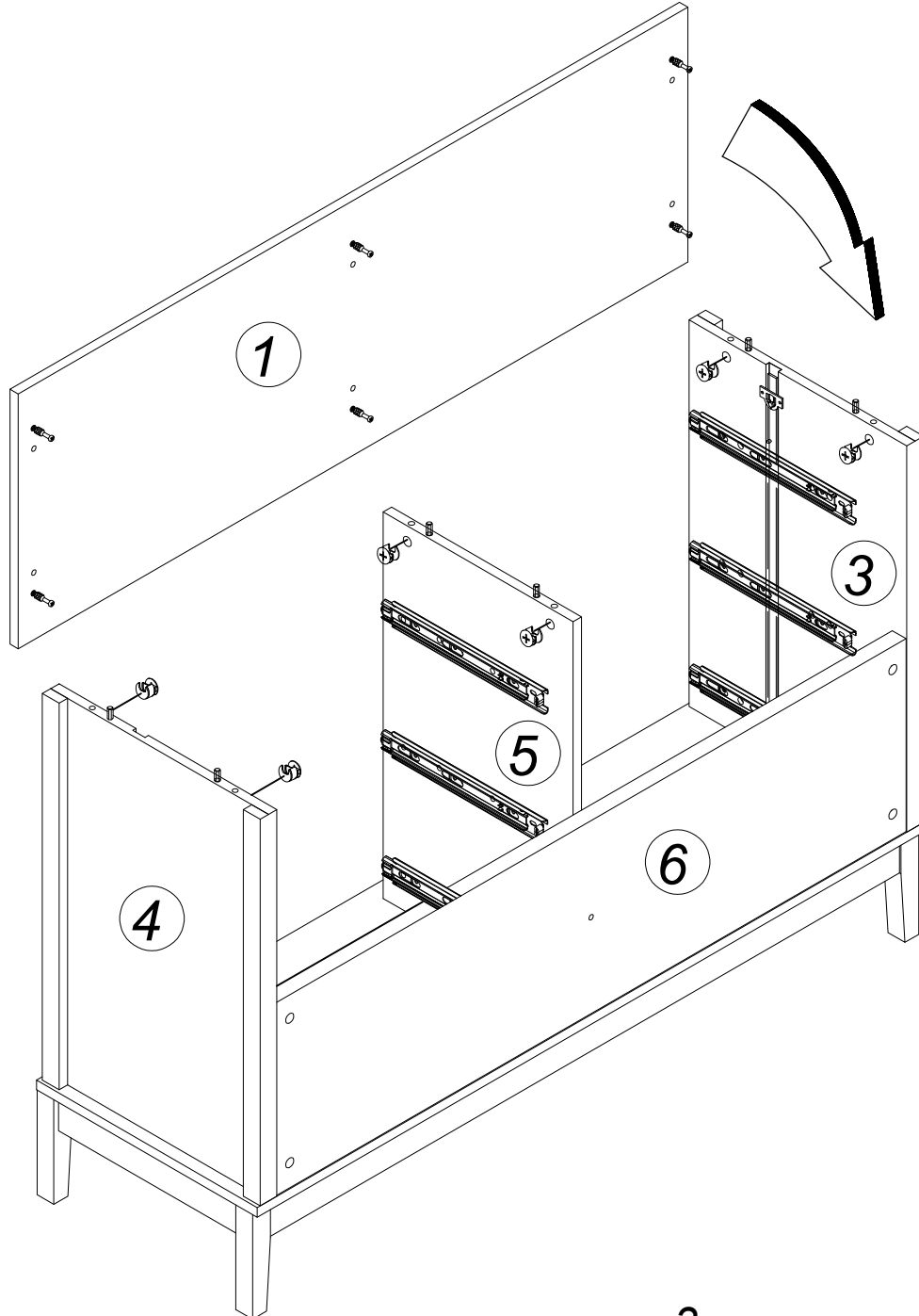

ASSEMBLY INSTRUCTION / INSTRUCCIONES DE MONTAJE

STEP 17

Q  NAIL

14 Pcs

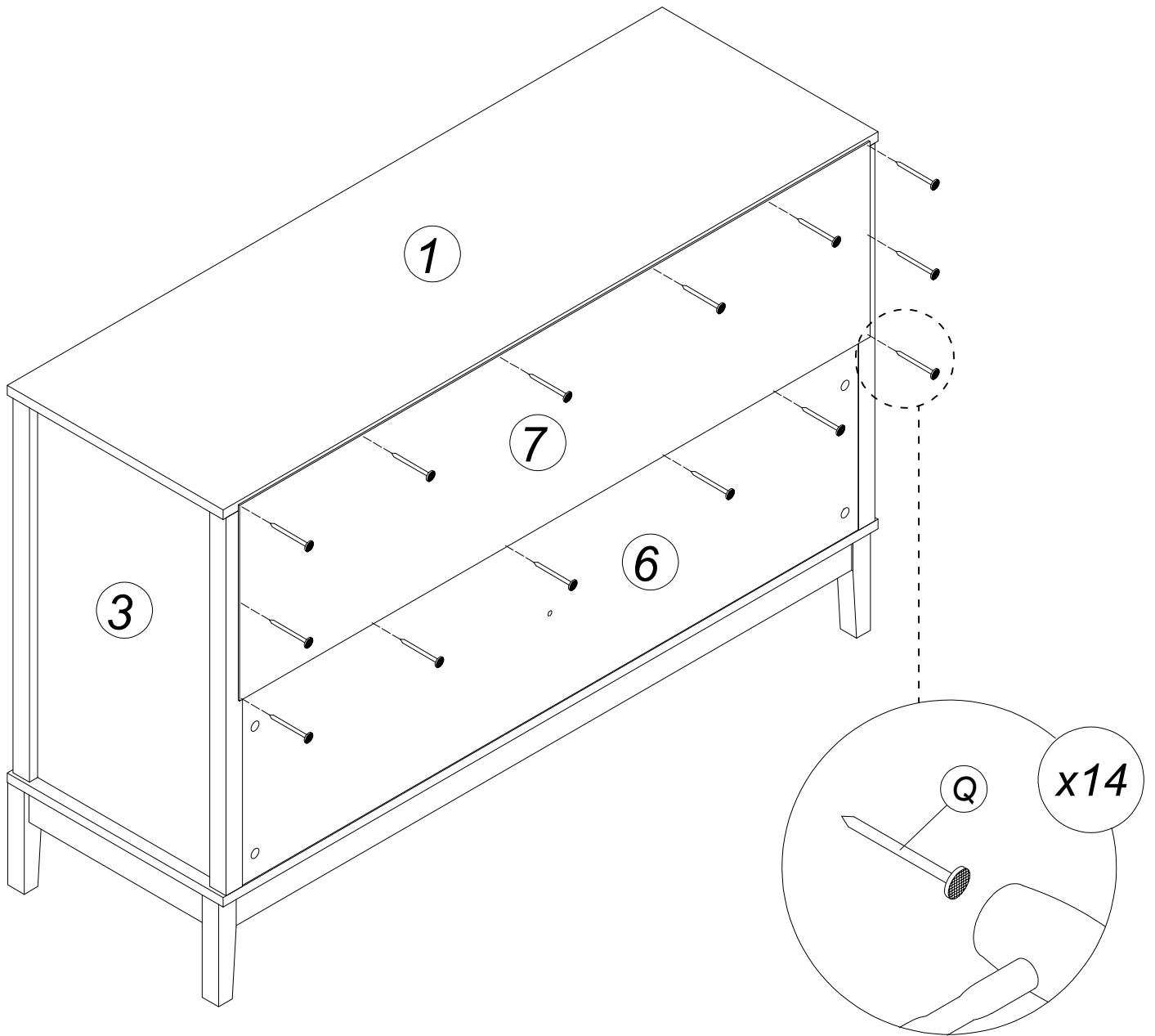

ASSEMBLY INSTRUCTION / INSTRUCCIONES DE MONTAJE

STEP 18

 N	CSK M4 X 32MM	12 Pcs
--	---------------	--------

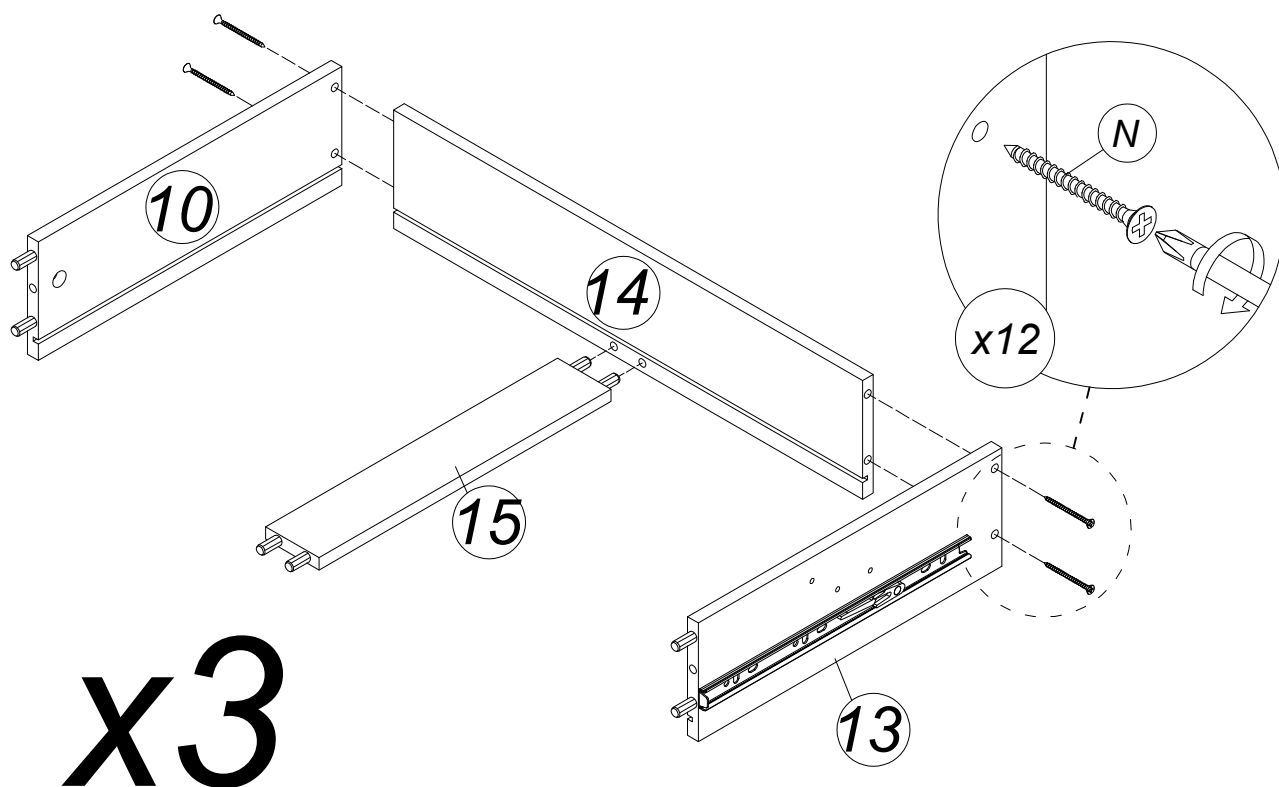

x3

DRAWER RIGHT

STEP 19

 N	CSK M4 X 32MM	12 Pcs
---	---------------	--------

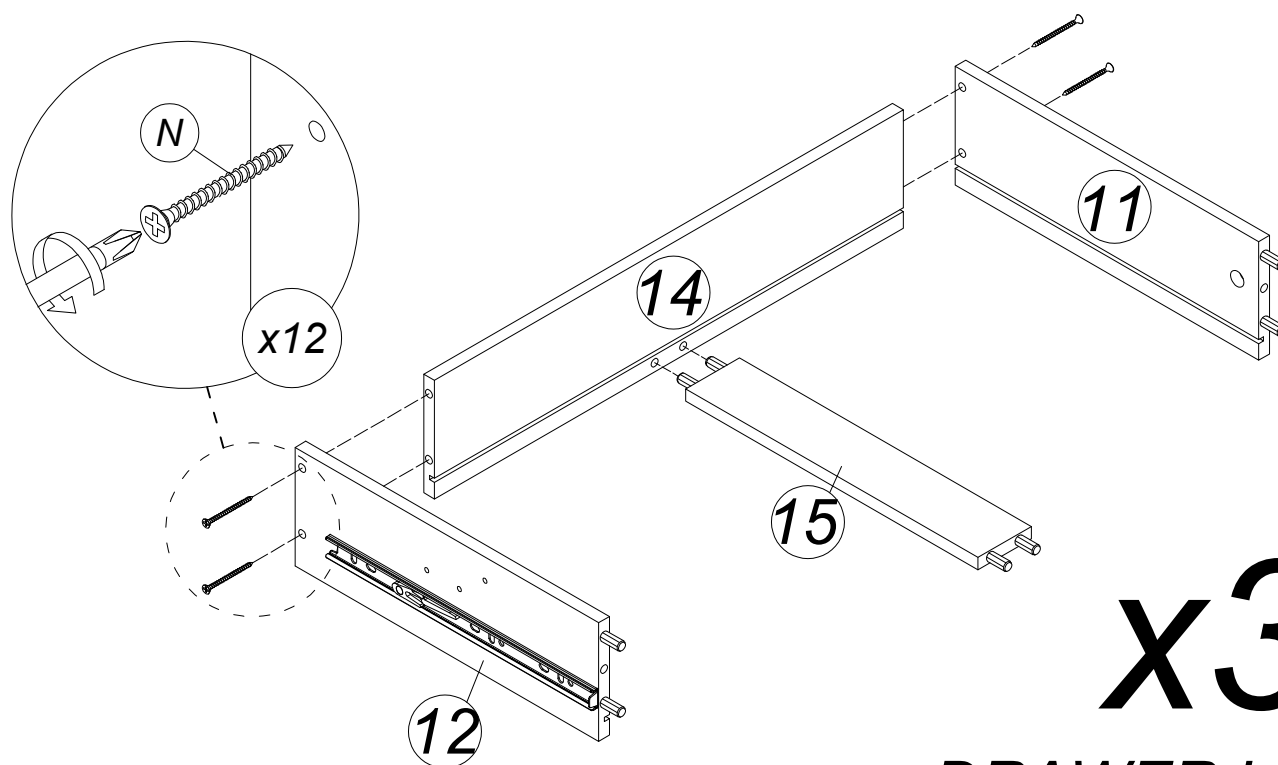

x3

DRAWER LEFT

ASSEMBLY INSTRUCTION / INSTRUCCIONES DE MONTAJE

STEP 20

H		STOPPER RIGHT	3 Pcs
J		PAN HEAD M3.5 X 16MM	9 Pcs

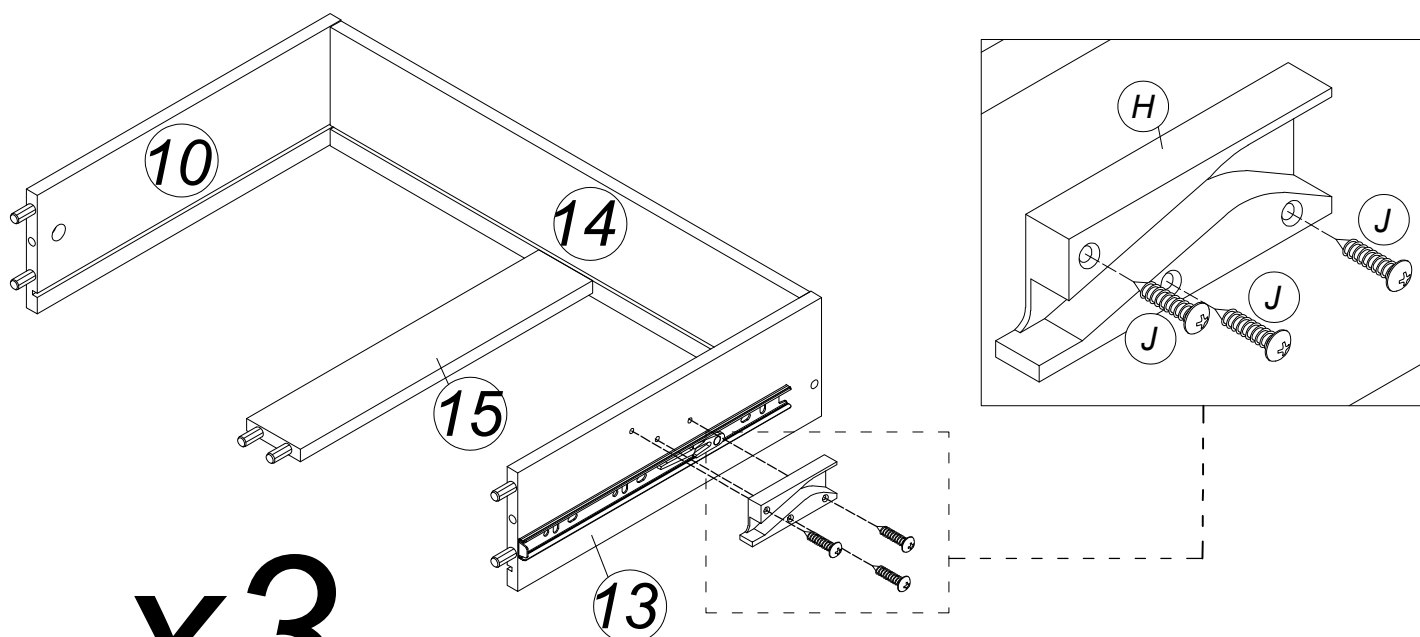

x3

DRAWER RIGHT

STEP 21

I		STOPPER LEFT	3 Pcs
J		PAN HEAD M3.5 X 16MM	9 Pcs

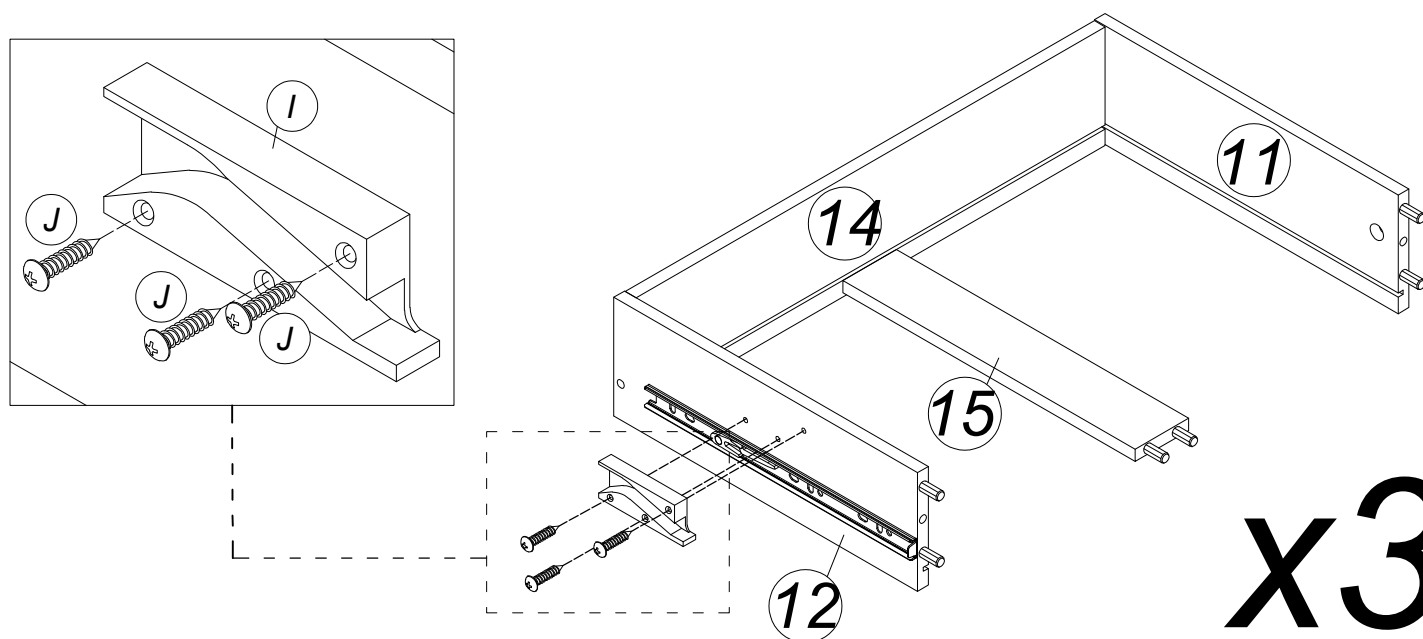

x3

DRAWER LEFT

ASSEMBLY INSTRUCTION / INSTRUCCIONES DE MONTAJE

STEP 22

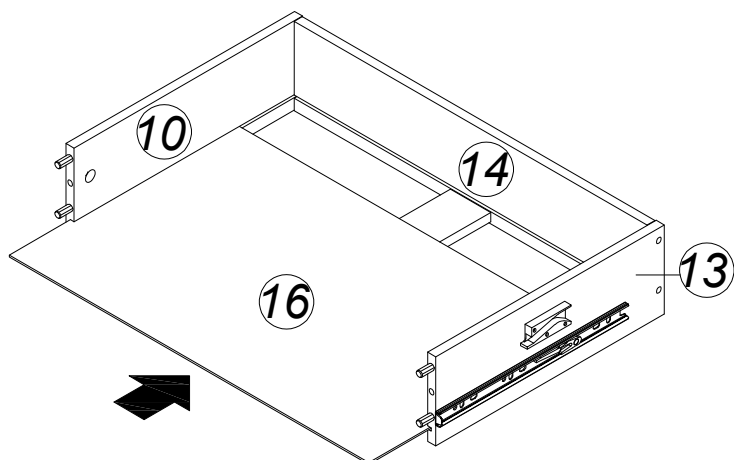

x3

DRAWER RIGHT

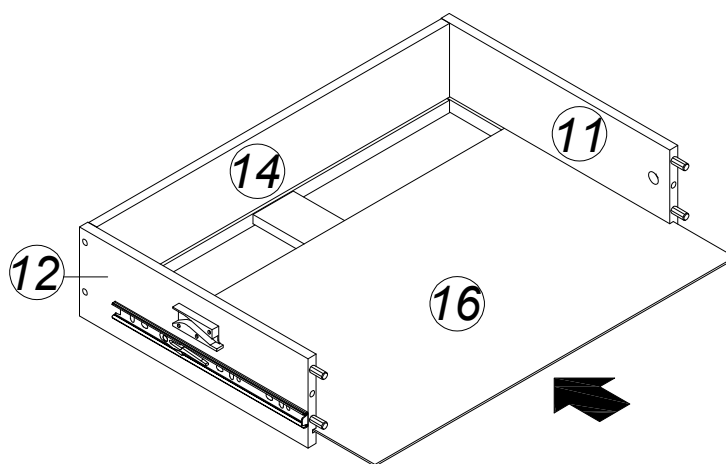

x3

DRAWER LEFT

ASSEMBLY INSTRUCTION / INSTRUCCIONES DE MONTAJE

STEP 23

L		MINICAM (12MM)	6 Pcs
---	---	----------------	-------

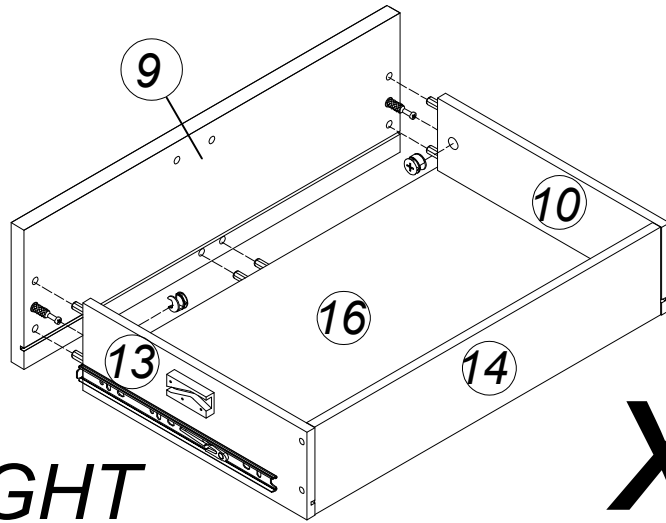

DRAWER RIGHT

x3

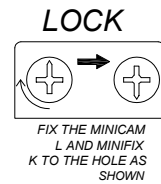
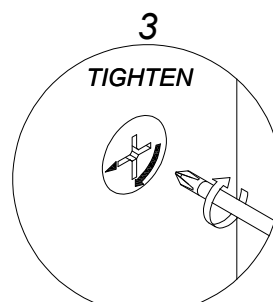
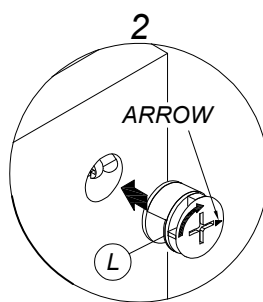
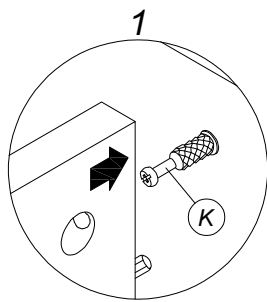

STEP 24

L		MINICAM (12MM)	6 Pcs
---	--	----------------	-------

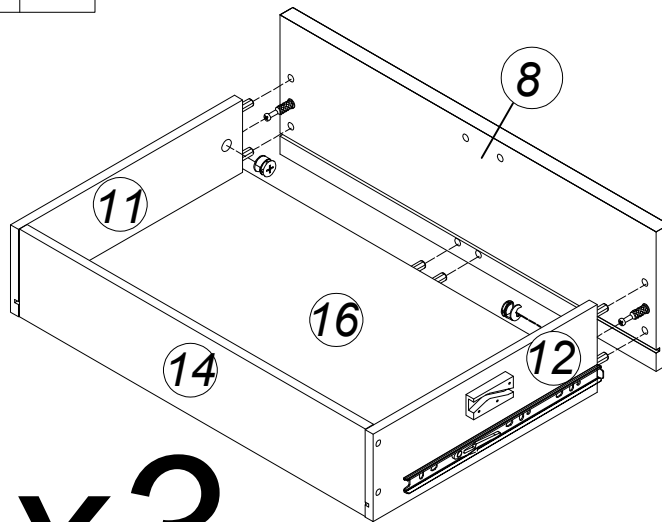

x3

DRAWER LEFT

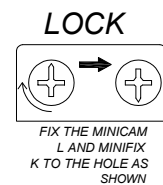
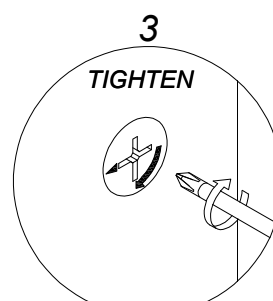
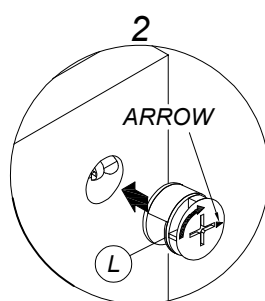
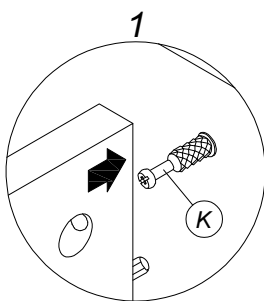

ASSEMBLY INSTRUCTION / INSTRUCCIONES DE MONTAJE

STEP 25

G		HANDLE SCREW M4 X 18MM	12 Pcs
F		HANDLE (96MM)	6 Pcs

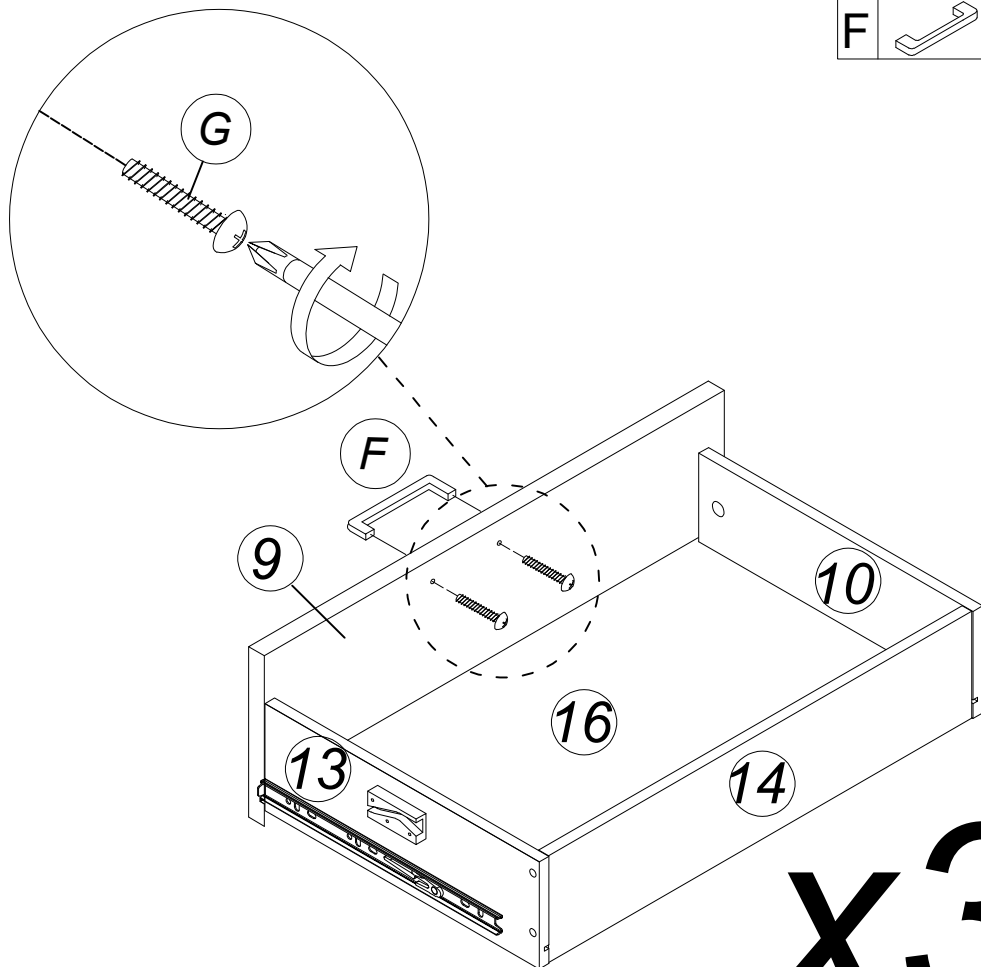

x3
DRAWER RIGHT

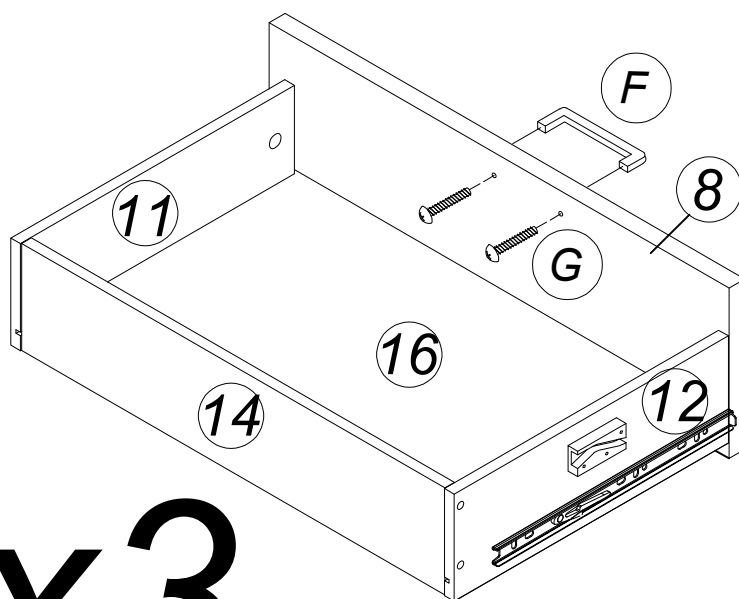

x3
DRAWER LEFT

ASSEMBLY INSTRUCTION / INSTRUCCIONES DE MONTAJE

Start by assembling the bottom most drawer first and work upwards /
Commencez par assembler le tiroir le plus bas et progressez vers le haut
/ Comience ensamblando primero el cajón más inferior y trabaje hacia
arriba.

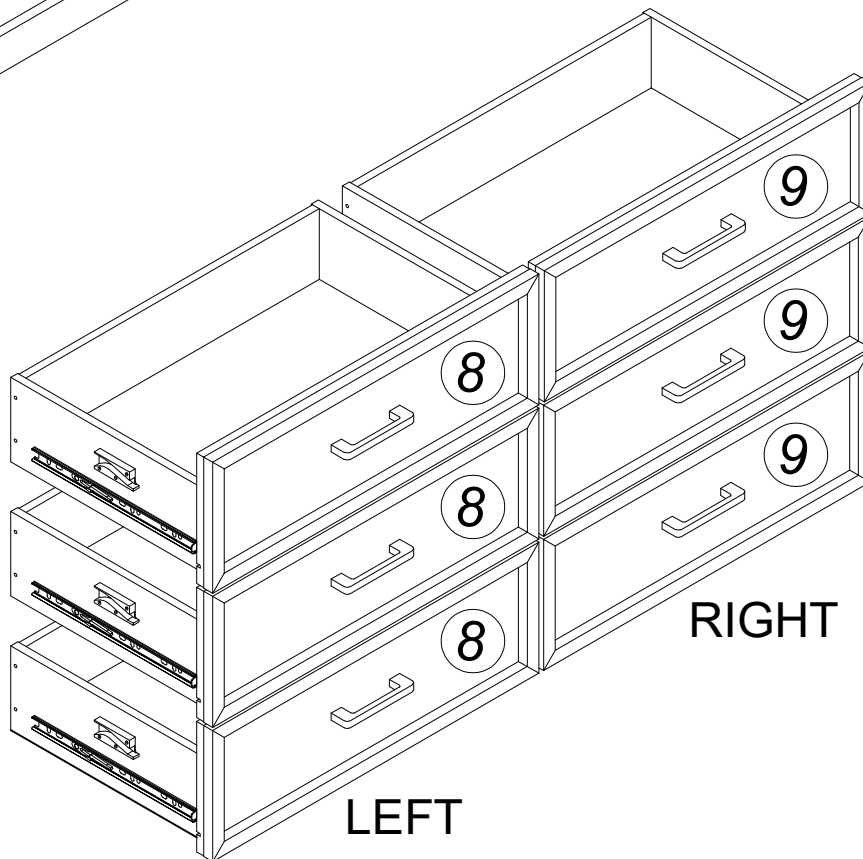
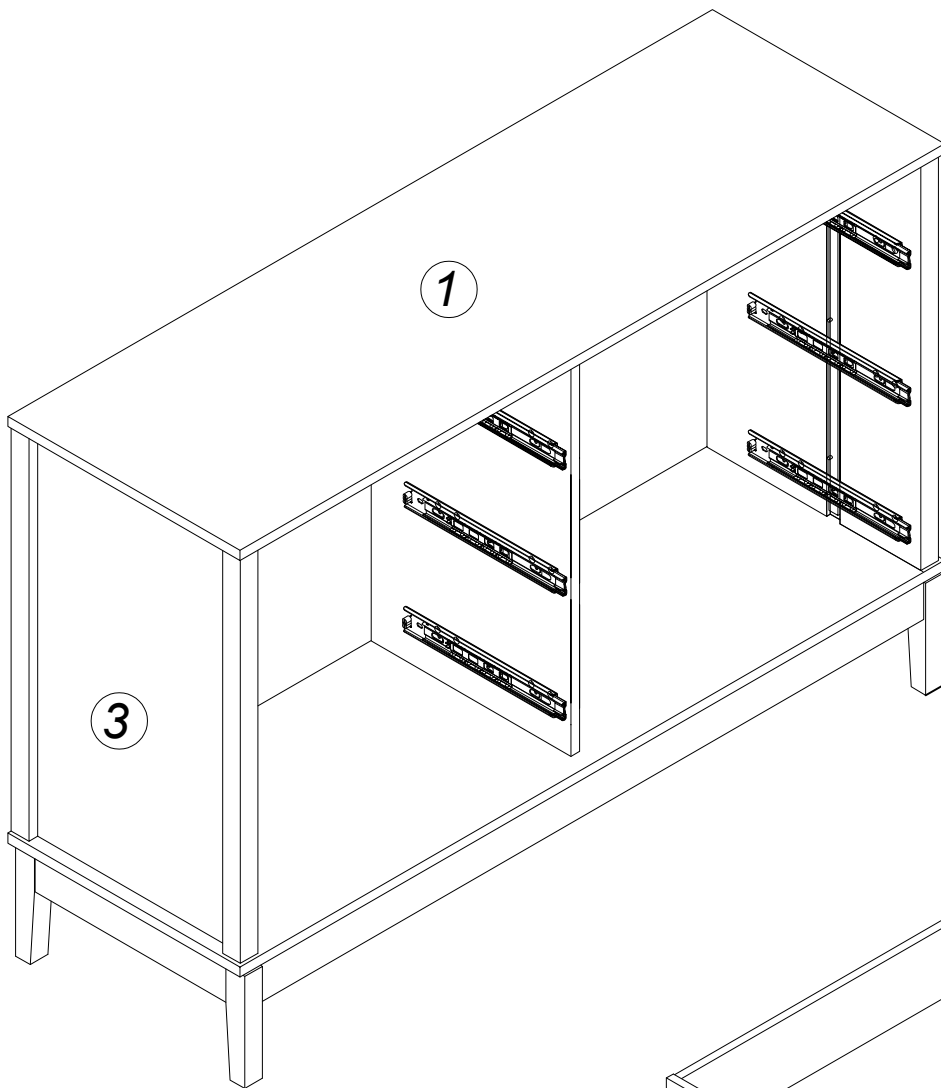

ASSEMBLY INSTRUCTION / INSTRUCCIONES DE MONTAJE

Make sure the interlock is in a state like the diagram / Assurez-vous que l'outil de verrouillage est dans un état similaire à celui du schéma / Asegúrese de que el enclavamiento esté en un estado similar al del diagrama

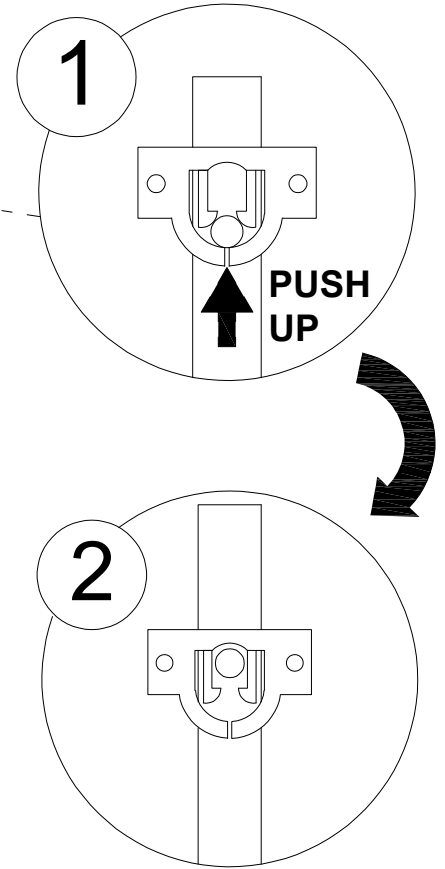
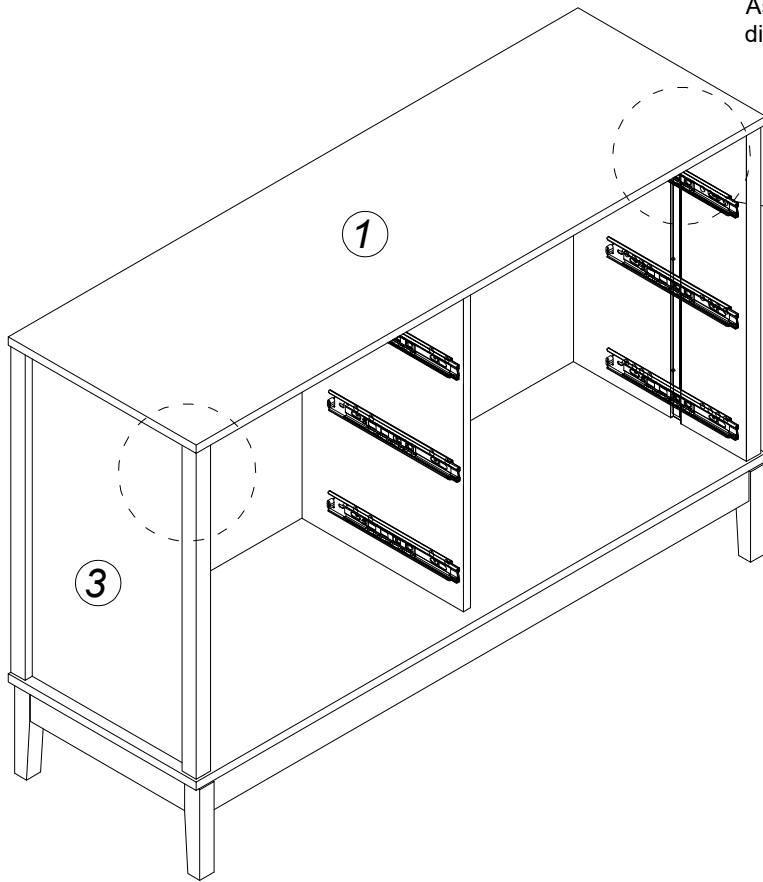

STEP 26

Assemble one by one drawer from bottom to top /
Ensamblar uno por uno cajón de abajo hacia arriba.

CAUTION / CAUTELA

Make sure to push drawer till full extension lock.

Asegúrese de empujar el cajón hasta que se bloquee la extensión completa.

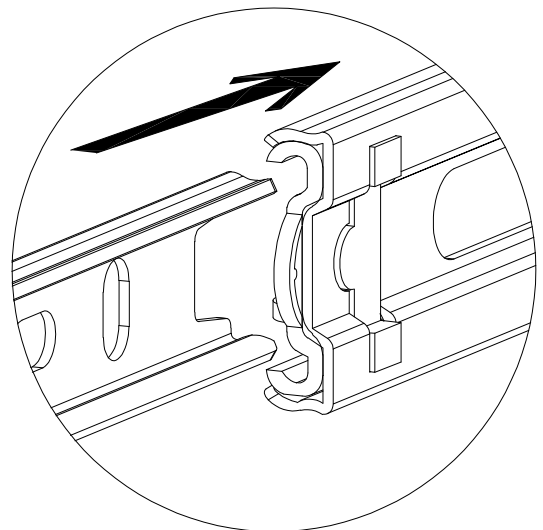
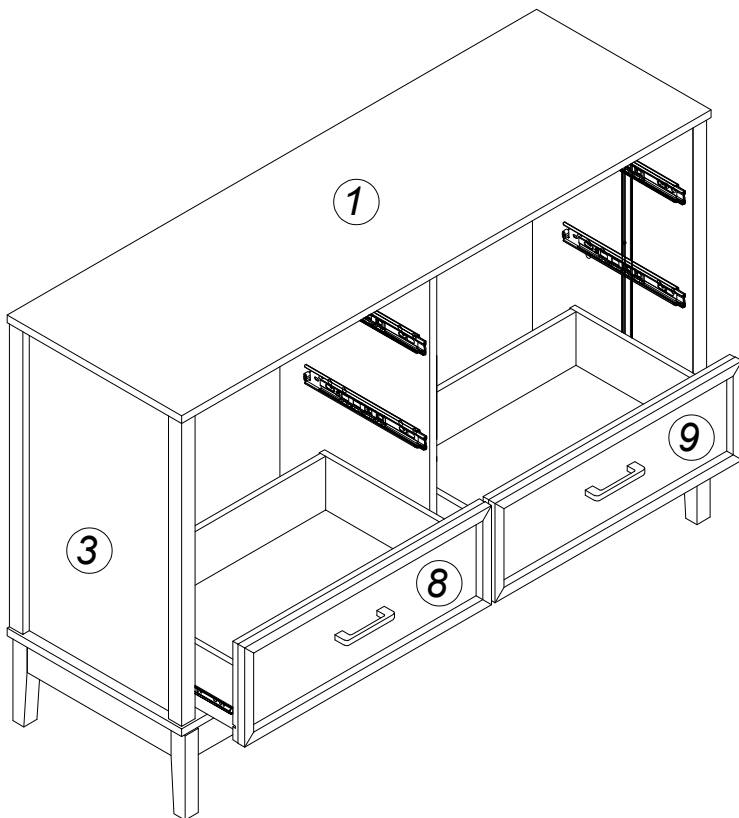

ASSEMBLY INSTRUCTION / INSTRUCCIONES DE MONTAJE

Make sure the interlock is in a state like the diagram / Assurez-vous que l'outil de verrouillage est dans un état similaire à celui du schéma / Asegúrese de que el enclavamiento esté en un estado similar al del diagrama

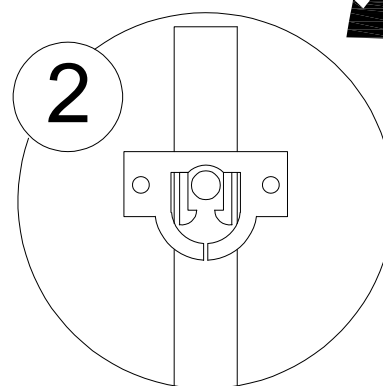
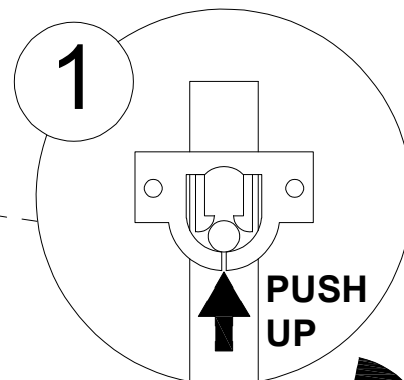
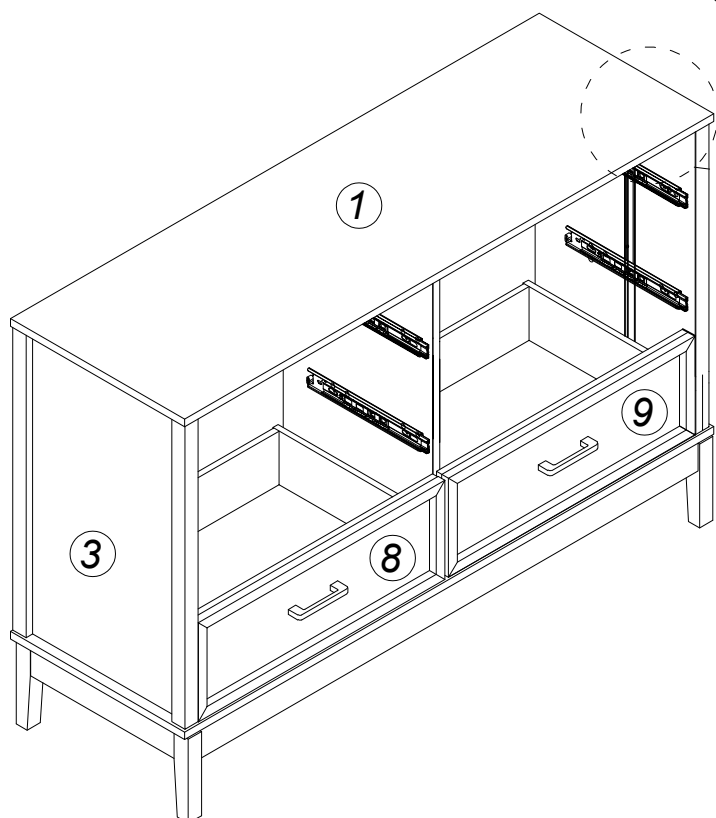

STEP 27

Assemble one by one drawer from bottom to top /
Ensamblar uno por uno cajón de abajo hacia arriba.

CAUTION / CAUTELA

Make sure to push drawer till full extension lock.

Asegúrese de empujar el cajón hasta que se bloquee la extensión completa.

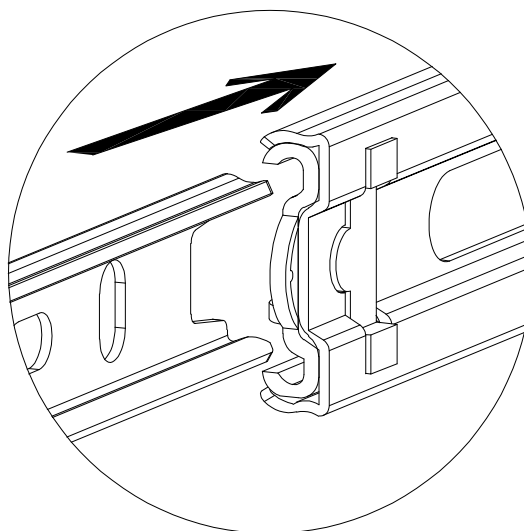
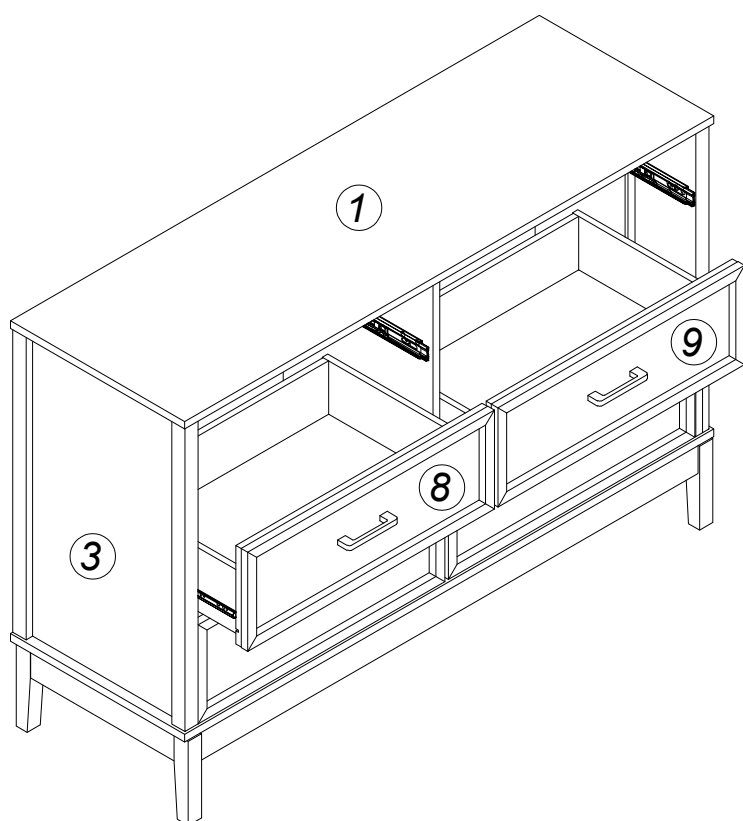

ASSEMBLY INSTRUCTION / INSTRUCCIONES DE MONTAJE

Make sure the interlock is in a state like the diagram / Assurez-vous que l'outil de verrouillage est dans un état similaire à celui du schéma / Asegúrese de que el enclavamiento esté en un estado similar al del diagrama

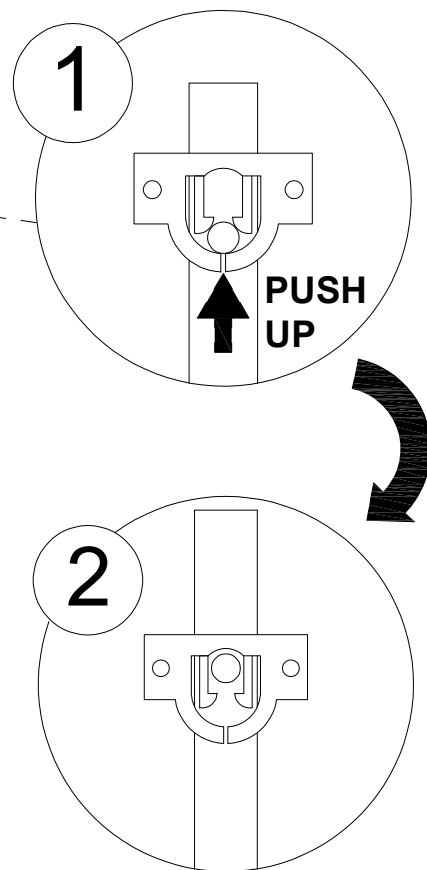
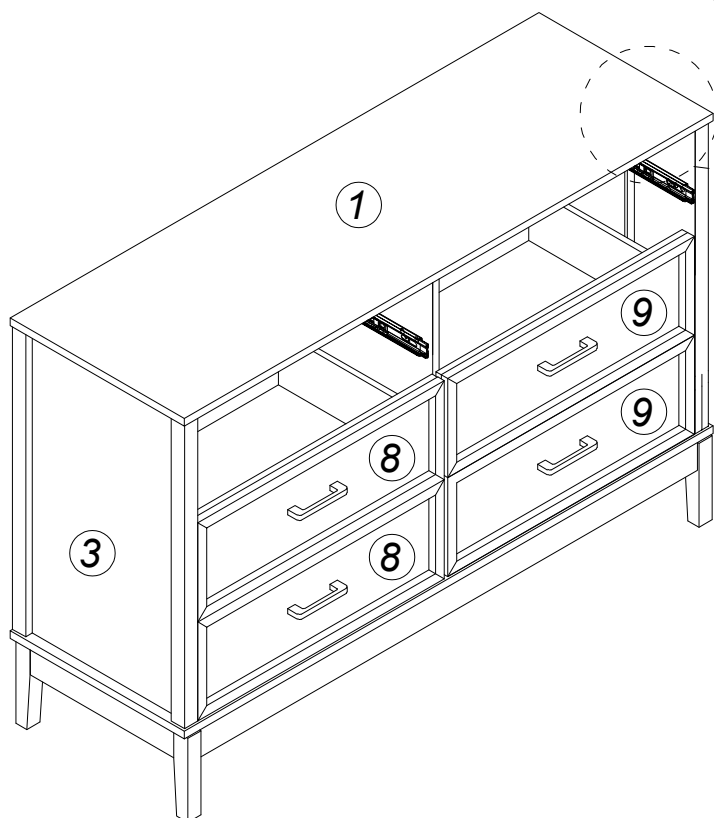

STEP 28

Assemble one by one drawer from bottom to top /
Ensamblar uno por uno cajón de abajo hacia arriba.

CAUTION / CAUTELA

Make sure to push drawer till full extension lock.

Asegúrese de empujar el cajón hasta que se bloquee la extensión completa.

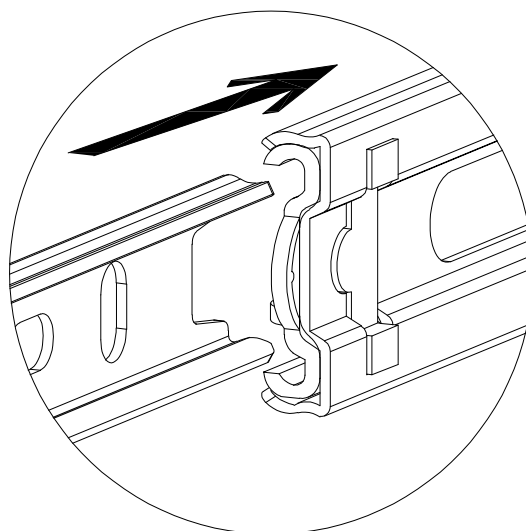
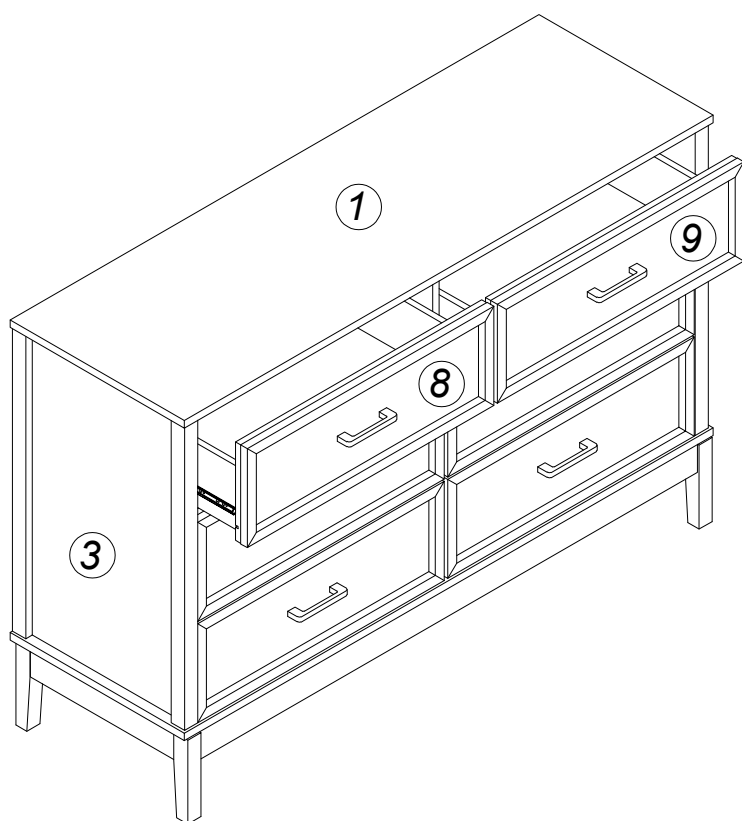

TIP-OVER PREVENTION / PRÉVENTION DU RENVERSEMENT / PREVENCIÓN DE VUELCOS

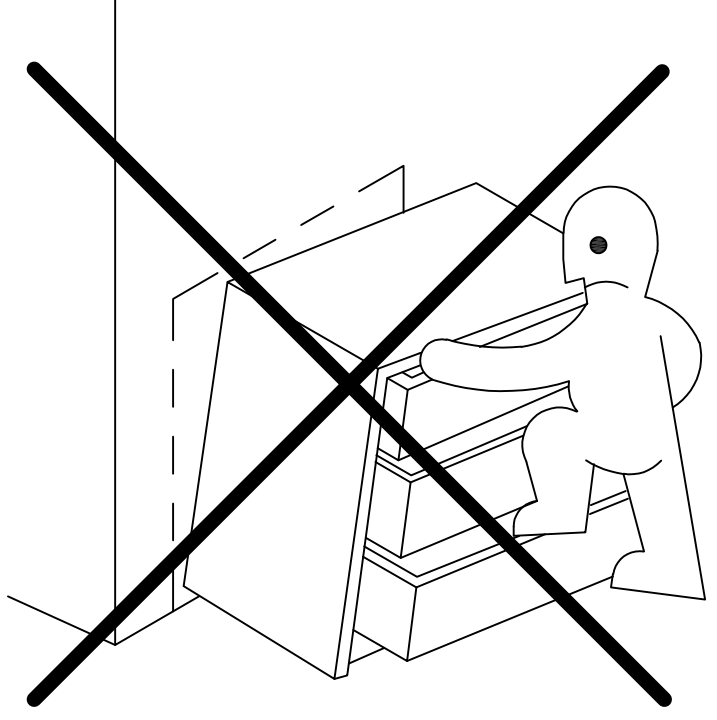
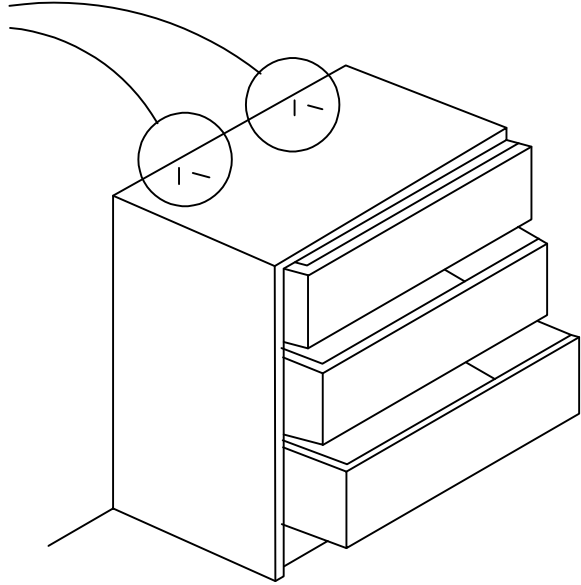

TIP-OVER HAZARD RISQUE DE BASCULEMENT PELIGRO DE VUELCO

STANDARD VERSION VERSION STANDARD VERSIÓN ESTÁNDAR

Complies with ASTM F2057-19 Standards

UPGRADED VERSION VERSION AMÉLIORÉE VERSIÓN ACTUALIZADA

Featuring Interlock system which complies with ASTM F2057-23 Standards

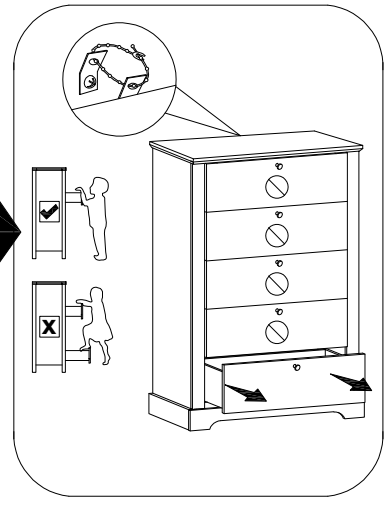
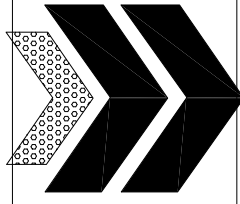
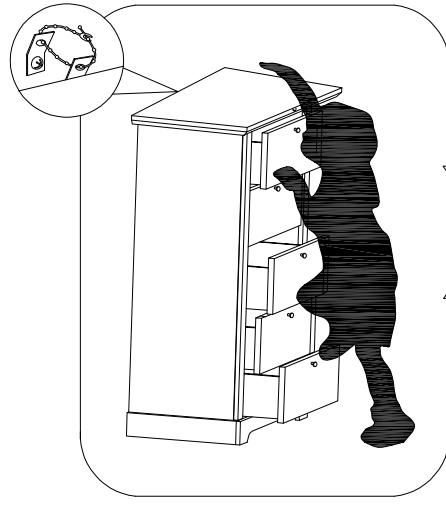

Disclaimer: Test methods in this safety specification are intended to simulate the reaction of a clothing storage unit on loaded drawers, multiple open drawers, and a dynamic force from possible interaction of child up to 72 months. This consumer safety specification does not apply to products that are blatantly misused, not does it apply to products used by consumers in a careless manner that violate normal practice or disregard the instructions or warnings provided with the product or both

Avertissement : Les méthodes d'essai de cette spécification de sécurité sont destinées à simuler la réaction d'une unité de rangement de vêtements sur des tiroirs chargés, plusieurs tiroirs ouverts et une force dynamique résultant d'une interaction possible d'un enfant jusqu'à 72 mois. Cette spécification de sécurité des consommateurs ne s'applique pas aux produits qui sont manifestement mal utilisés, ni aux produits utilisés par les consommateurs de manière négligente qui enfreignent les pratiques normales ou ne tiennent pas compte des instructions ou des avertissements fournis avec le produit, ou les deux.

Descargo de responsabilidad: Los métodos de prueba de esta especificación de seguridad tienen como objetivo simular la reacción de una unidad de almacenamiento de ropa en cajones llenos, cajones abiertos múltiples y una fuerza dinámica de la posible interacción de un niño de hasta 72 meses. Esta especificación de seguridad para el consumidor no se aplica a productos que se usan de manera incorrecta de manera evidente, ni a productos utilizados por consumidores de manera descuidada que violan la práctica normal o ignoran las instrucciones o advertencias proporcionadas con el producto o ambas.



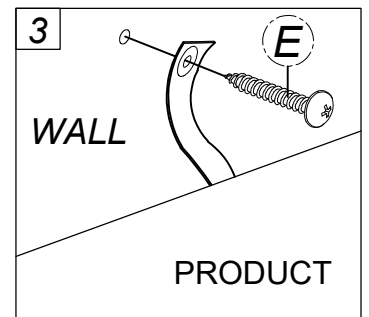
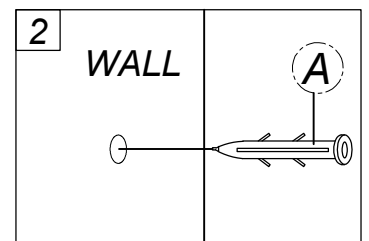
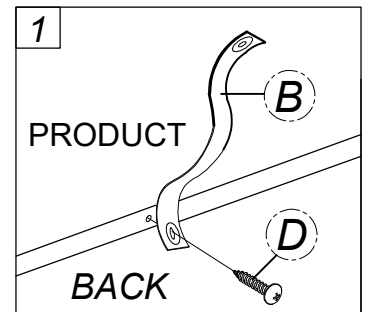
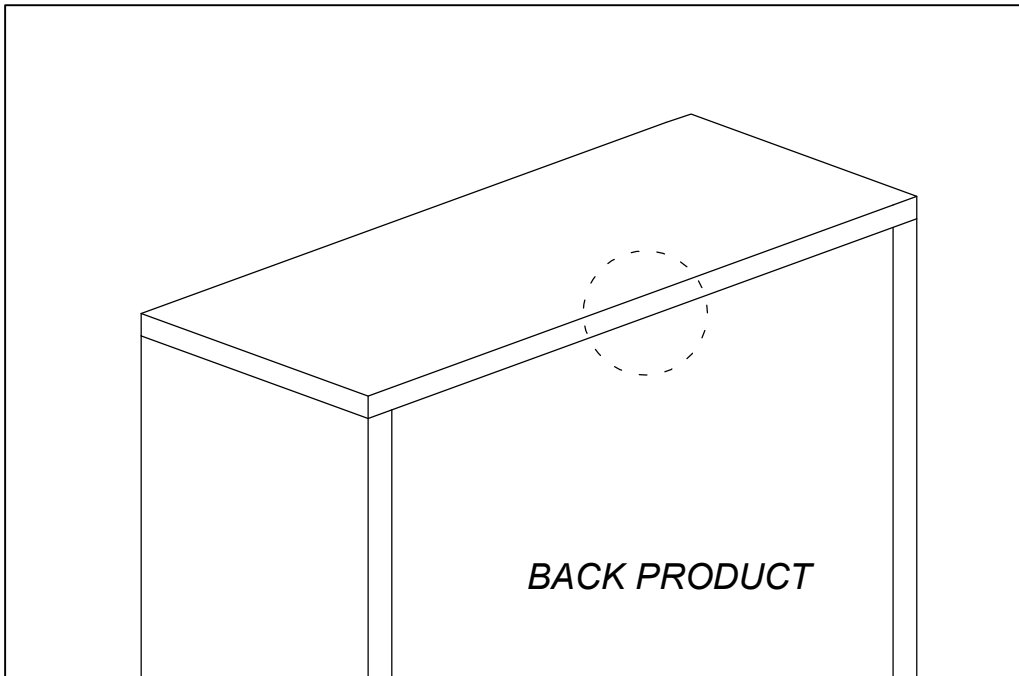

FURNITURE TIPPING RESTRAINT / RETENEDOR DE VUELCO DE MUEBLES

- Serious or fatal injuries can occur from furniture tipping over. To prevent the furniture from tipping over we recommend that it is permanently fixed to the wall.
- Wall fixings are not supplied with this product as different wall materials require different types of fixing devices. Please make sure you use fixings suitable for the walls in your home.
- Pueden producirse lesiones graves o mortales por el vuelco de los muebles. Para evitar que los muebles vuelquen, recomendamos fijarlos permanentemente a la pared.
- No se suministran fijaciones de pared con este producto, ya que los diferentes materiales de pared requieren diferentes tipos de dispositivos de fijación.

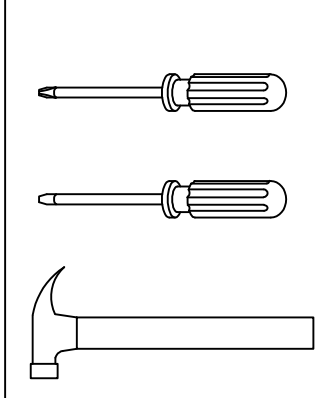

NOT Provided



A	WALL PLUG		1
B	SAFETY STRAP WITH WASHER		1
D	SCREW #6 X 16MM		1
E	SCREW #8 X 25MM		1

USE OF POWER TOOLS TO ASSEMBLE THIS PRODUCT WILL INVALIDATE ANY CLAIM AND MAY DAMAGE THIS PRODUCT MAKING IT UNSAFE

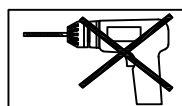

MAXIMUM LOAD / CARGA MÁXIMA

This units has been design to support the maximum loads. Exceeding these load limits could cause sagging, instability, product collapse, and/or serious injury.

Esta unidad ha sido diseñada para soportar las cargas máximas. Si se superan estos límites de carga, Podría causar flacidez, inestabilidad, colapso del producto y/o lesiones graves.

CAUTION !!!/PRECAUCIÓN !!!

- *This item cannot be dragged /
Este elemento no
se puede arrastrar.*
- *Please lift it to move /
Por favor,
levántalo para moverte*

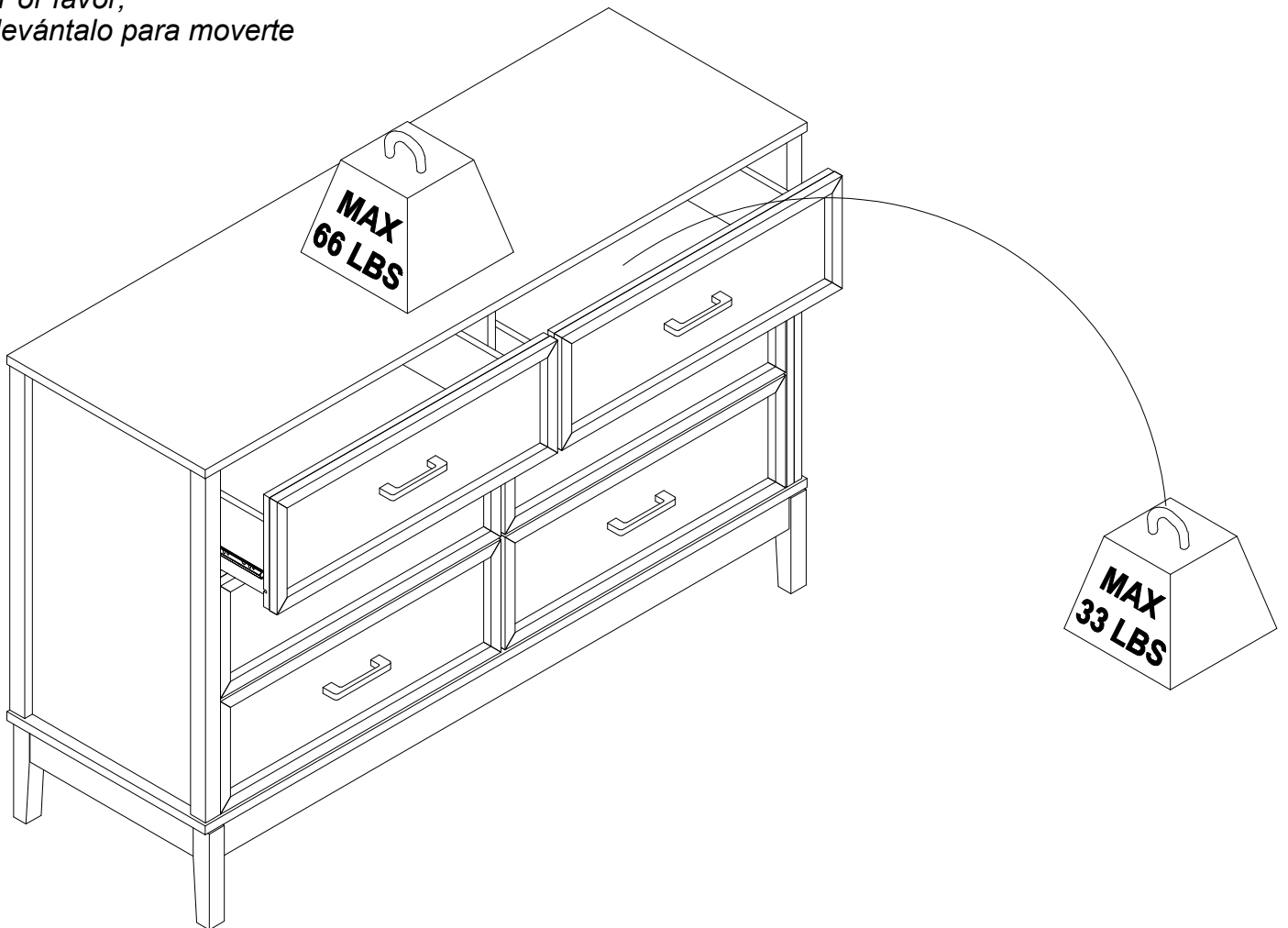

WARNING / ADVERTENCIA

Serious or fatal injuries can occur from falling furniture. To prevent furniture from falling, please do:

La caída de muebles puede provocar lesiones graves o fatales. Para evitar la caída de muebles, haga lo siguiente:

- Install the tipover restraint provided /
Instale el dispositivo de retención antivuelco provisto.
- Place heaviest items in the lowest rack /
Coloque los artículos más pesados en el estante más bajo.
- Do not let children climb or hang on drawers, doors, or shelves /
No permita que los niños se suban o se cuelguen de cajones, puertas o estantes.

The use of tip over restraints may only reduce and not eliminate the risk of failing furniture.

El uso de dispositivos antivuelco solo puede reducir, pero no eliminar, el riesgo de que los muebles se caigan.