

nestl[®]

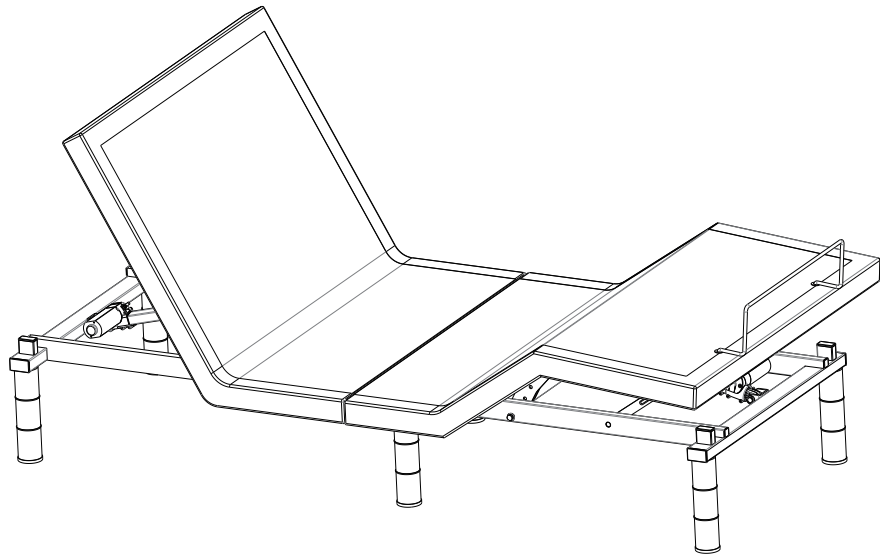

Installation Guide

Adjustable Bed Frame



CONTENTS

1. Instructions for use	P1
2. Product Parameters	P2
3. Installation Preparation	P2
4. Component List	P3
5. Installation Guide	P4-P8
6. Remote Control Functional Specification	P9-P11
7. Remote Control Pairing	P12
8. Installation for Sync Sheet	P13
9. Electrical Configuration Diagram	P14
10. Backup Battery Device	P15
11. Troubleshooting	P16-P17
12. Notes	P18

Instructions for use

Main Material

Main Material	Application site
Carbon steel pipe	Base frame
Plastic	Electrical enclosure
Fabric	Bedsread
Wood board	Bed canopy

Executive Standard

Q/NLG 010-2023

Product Parameters

Product name	Wooden upholstered electric adjustable bed				
Item No.	NB-AB-TXL	NB-AB-Q	NB-AB-K	NB-AB-CK-New	
Bed size	78.7"x37"	78.7"x58.7"	78.7"x74.8"	70.9"x82.7"	
Foot size	3/6/9/12 inches				
Back angle	0°~60°	Leg angle	0°~45°	Decible	< 60dB
Input power	AC100V~240V	Load capacity	750lbs		

Installation Preparation

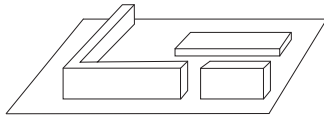

Install on carpet to prevent scratches.

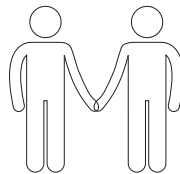

Need two or more people to cooperate together.

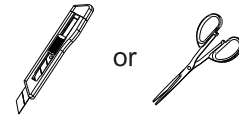

Knife or scissors. (prepared by customer)

Component List

Unpack the case and you can see

1 Bed Frame (x1)

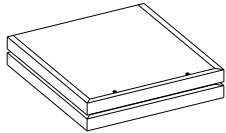

2 Mattress Retainer Bar (x1)

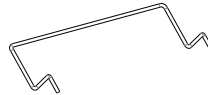

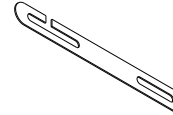

3 Sync Sheet (x1)

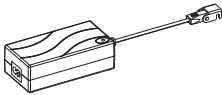
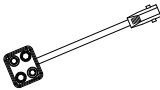
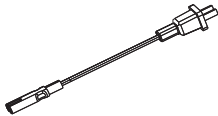
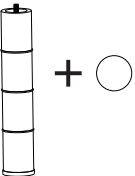

(Only for TXL)

Core Accessories Package

<p>1 Remote Control (x1)</p>	<p>2 Adaptor (x1)</p>	<p>3 Standby Battery Strap (x1)</p>	<p>4 AC Power Cord (x1)</p>
			
<p>5 Adjustable Leg/ Bed Foot Pad (x6)</p>	<p>6 Sync Cord (x1)</p>	<p>7 Battery (x3)</p>	
	 <p>(Only for TXL)</p>		

Installation Guide

STEP 1

- a Open the box lid and take out the bed. Make sure not to puncture the box with any sharp objects.
- b Place the bed frame on a clean and level place (as shown).
- c Take out all the accessories from the package and put them aside.

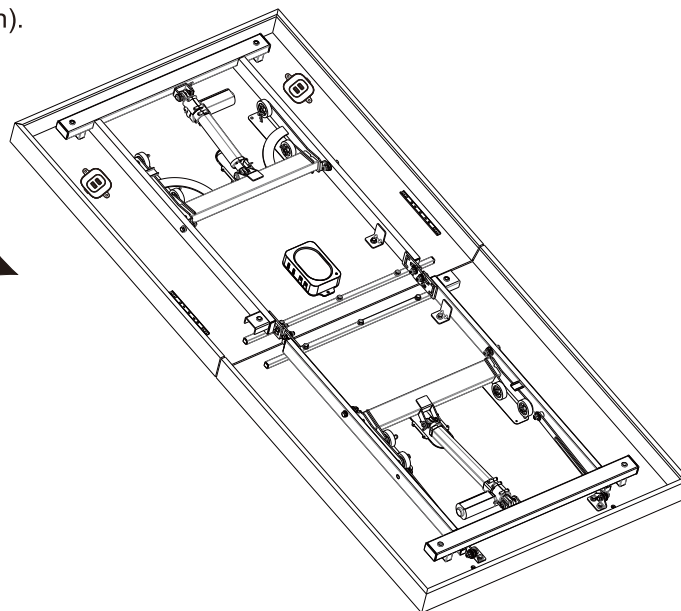
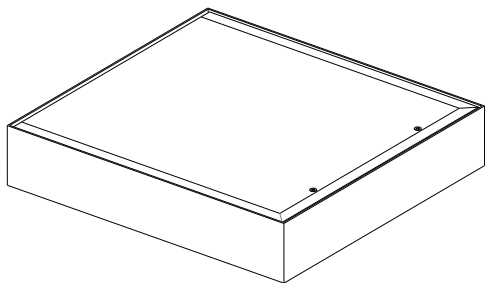

<The picture only shows the installation steps, the product is subject to the actual product>

STEP2

- a** Connect the transfer cord reserved on the control box to the power adaptor.
- b** Connect the power cord (control box) to the power adaptor.

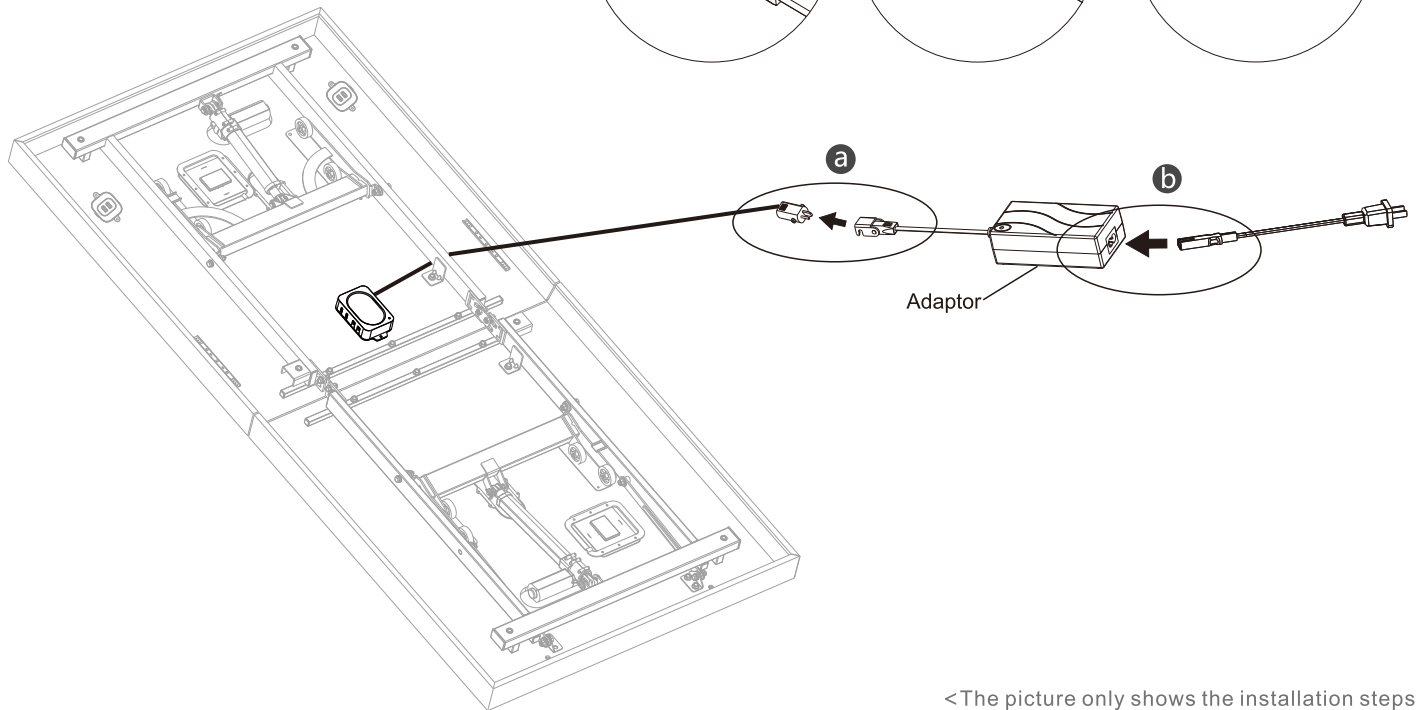
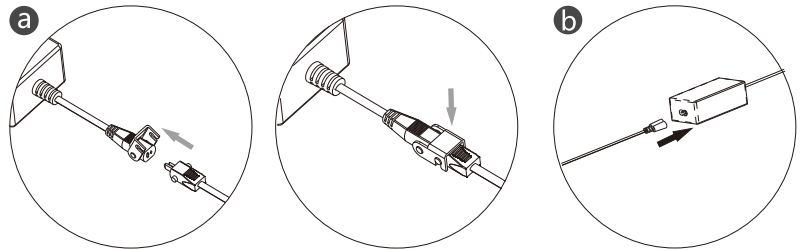

<The picture only shows the installation steps,
the product is subject to the actual product>

STEP 3

- a With the bottom of the bed frame facing up, install the legs and tighten.
- b Please stick the foot pads to the bottom of the bed legs.

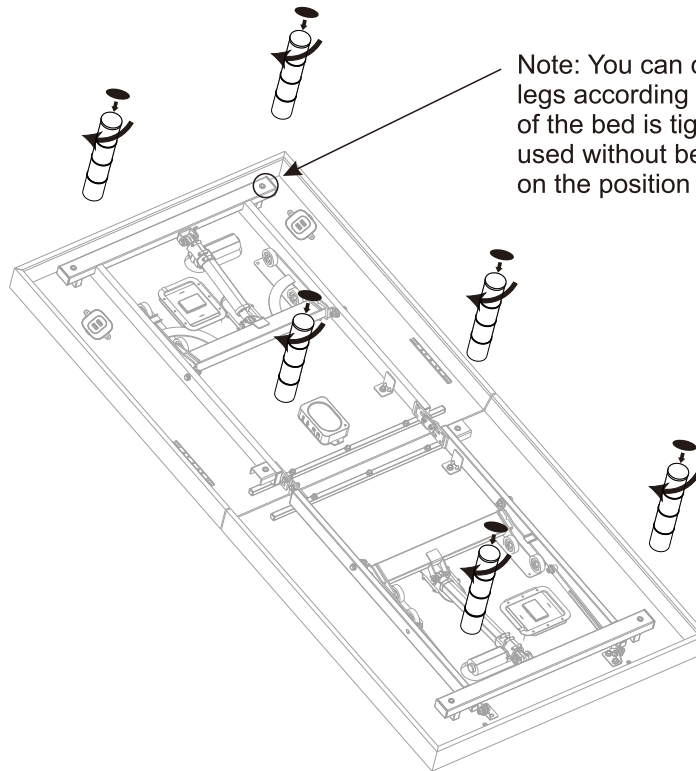

Note: You can choose to install 1, 2 or 3 sections of bed legs according to your needs. Make sure that each section of the bed is tightened between the feet. (It can also be used without bed legs, but you need to paste the leg pads on the position where the bed legs are installed.)

<The picture only shows the installation steps, the product is subject to the actual product>

STEP4

After turning the bed over, install the mattress bar according to the position of the jack.

Reminder: During daily use, please do not drag the bed, as there is a risk of bending the foot of the bed.

Warning



1. Two people are required to turnover the bed gently.
2. It is forbidden to have a single leg endure the weight during transportation and turnover.

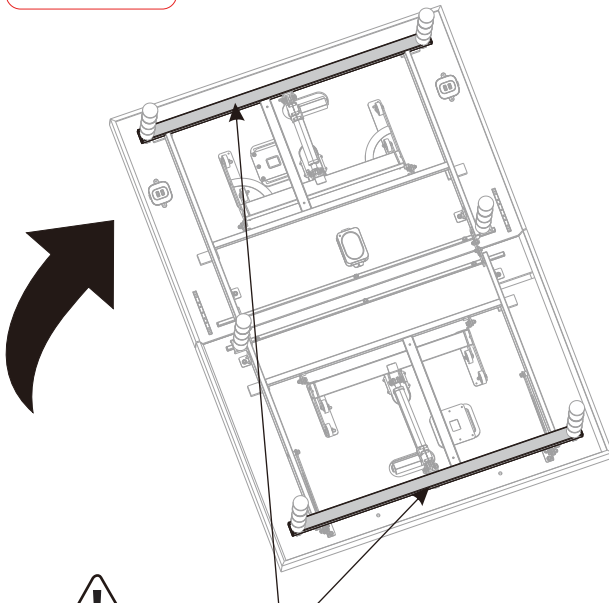

When moving this product, please hold the crossbeam here tightly, and do not move it by holding the bed surface

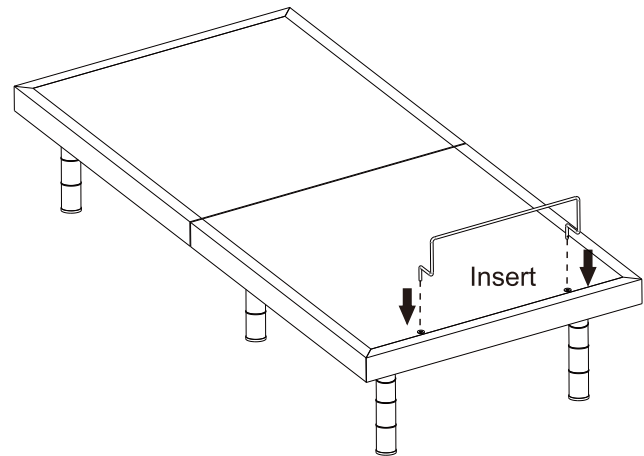

<The picture only shows the installation steps, the product is subject to the actual product>

STEP5

Use an AC power cord to connect the power supply and the socket



When the product is in a non-flat state, please do not perform strong impact sports such as jumping.

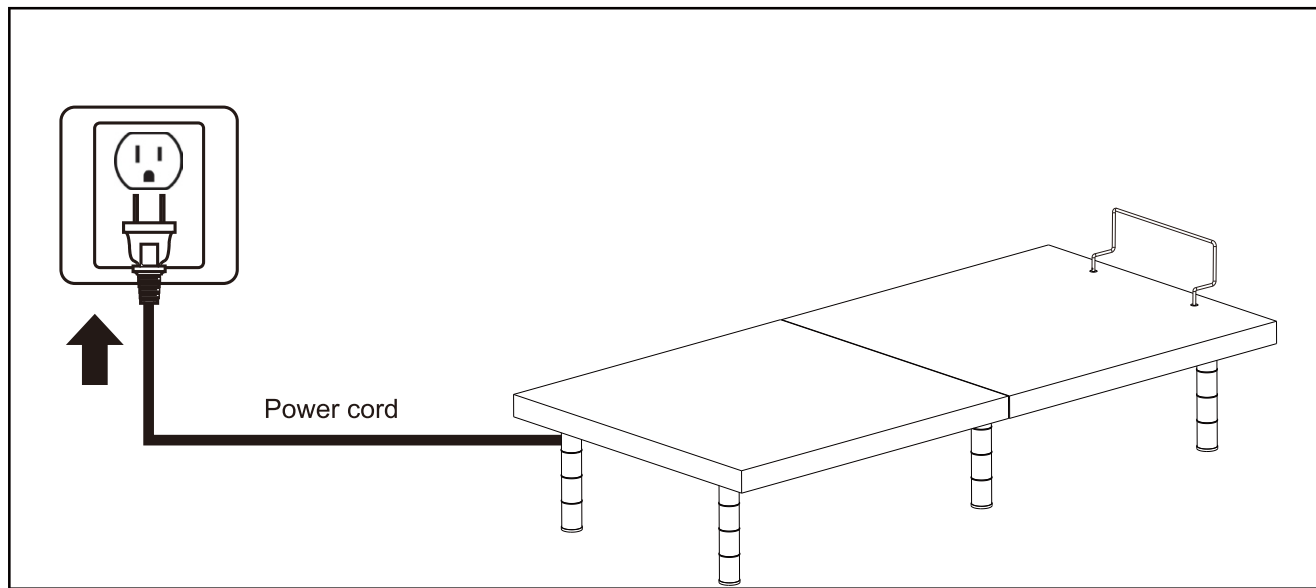

<The picture only shows the installation steps,
the product is subject to the actual product>

Remote Control Functional Specification

● Remote Overview:

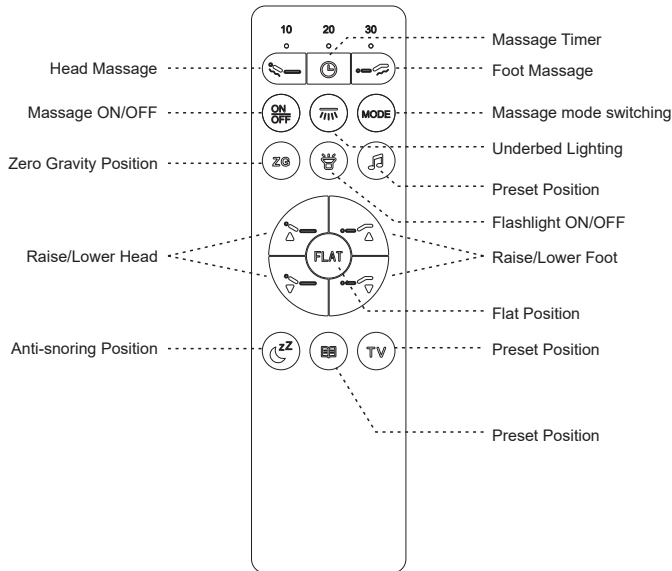

	Adjust the massage intensity of head and foot vibrator from 0 to 6 level
	Select 10, 20, 30 minutes massage time
	One button to control the head and foot vibrators to turn on/off together
	Used to turn the underbed lights ON/OFF
	Click the button to control the vibration mode switch, there are 3 modes in total, each click changes the mode once, and the mode cycles with the button click: 0-1-2 - 3-0-1 - 2-3-0 - 1
	One touch to zero gravity preset position
	Turn the remote flashlight ON/OFF.
	Raise/lower the head section of the base
	Raise/lower the foot section of the base
	One touch FLAT preset position
	One touch preset position
	One touch tv preset position
	One touch READING preset position
	One touch anti snore preset position

Remote Control Functional Specification

- Memory position function:

These four one touch buttons can be reached to preset positions by one touch, or can also be set as a memory position as needed.

First adjust the head and foot to your desired position, and then set a memory position as shown in the figure below.

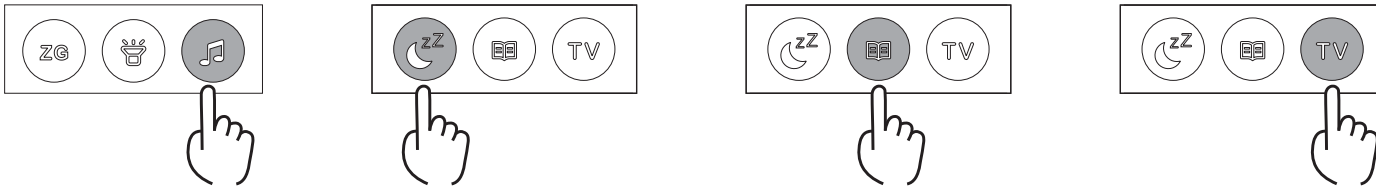

Press and hold the "🎵" or "zzz" or "📺" or "TV" button for 5 seconds. The backlight will flash 3 times to indicate that the memory position has been saved.

- Child lock function:

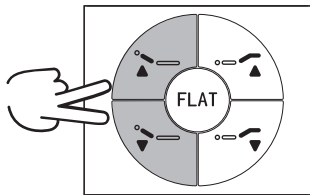

a. To activate the Child Lock function, simultaneously press and hold the "🔒" and "FLAT" buttons for 3 seconds. The backlight will flash 3 times and then remain steady indicating that the Child Lock is now enabled.

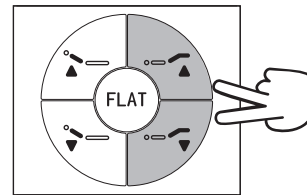

b. To deactivate the Child Lock function, simultaneously press and hold the "🔒" and "FLAT" buttons for 3 seconds. The backlight will initially flash 2 times, followed by another flash of 3 times before finally turning off completely. This indicates that the Child Lock is now disabled, and the buttons' functionalities have been restored.

Remote Control Functional Specification

● Reset function

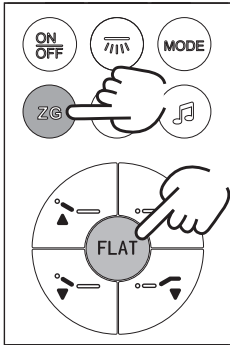

a. Press and hold the "ZG" and "FLAT" buttons simultaneously for 5 seconds, the backlight will flash 3 times, and all functions will be restored to factory settings.

● Synchronization function: (For TXL only)

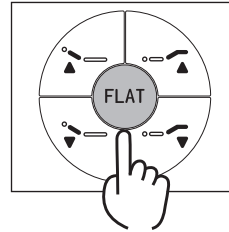

- a. To enable sync function: Press and hold the "FLAT" button for 5 seconds, the backlight of the remote control will flash 3 times and remain on. (Release to turn it off)
- b. To disable sync function: Press and hold the "FLAT" button for 5 seconds, the backlight of the remote control will flash 3 times and turn off.

Note

1. Before using the sync function, please refer to the "Sync Panel Installation" and install the sync line and sync panel.
2. When using the sync function, only one remote control is needed. Please do not use two remote controls to operate at the same time.
3. After successfully enabling the sync function, the two beds will automatically level. Any remote control operation related to bed elevation during the leveling process will interrupt the sync and cause the sync to fail.

Remote Control Pairing

When the product is shipped, the remote control and the adjustable bed are already paired. If the remote control buttons are found to be ineffective or a new remote control is replaced, please follow the following steps to re-pair.

1. Unplug the power, wait for the adapter indicator to go off, and then power on. Within 10 seconds after the entire bed is powered on, simultaneously press and hold the "↵" and "↶" buttons.
2. The backlight of the remote control flashes to indicate entering the pairing status. If it subsequently goes off, it means that pairing was successful. Otherwise, it will keep flashing.
3. After successful pairing, click the "FLAT" button to reset the bed: once it is completely flat, the remote control can be used normally.

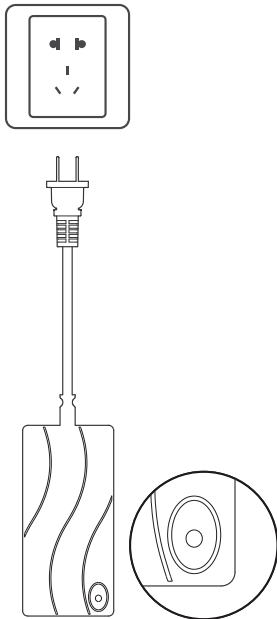

1 Unplug the power, make sure the adapter light is off

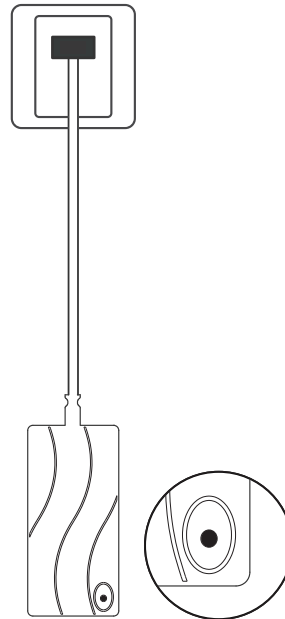

2 plug in

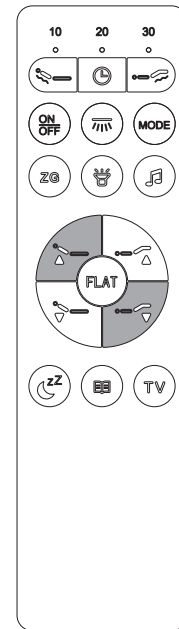

3 Press and hold "↵" and "↶" at the same time within 10 seconds

Installation for Sync Sheet (Optional, only for TXL)

When leaving the factory, the sync sheet is fixed on the base, and the installation of the sync sheet requires the feet of the bed.

1. Connect both ends of the sync cord to the control boxes of the two beds respectively.
(Only one sync cord is required)

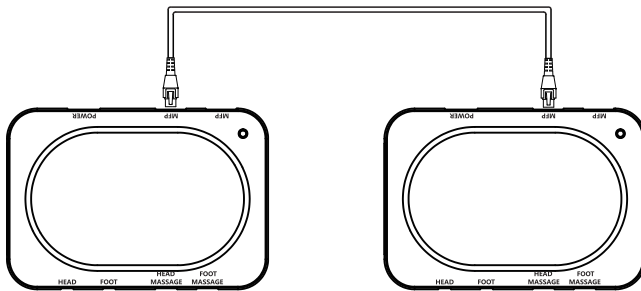

3. Swing the synchronous piece, connect the b end to the back bed foot bolt of the other bed, and then tighten the bed foot.

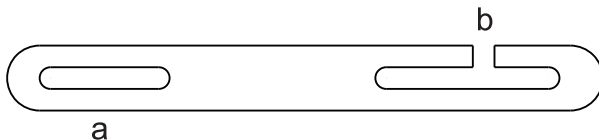

2. Unscrew the back foot of the bed, buckle the end of the synchronous sheet into the screw of the bed foot, and screw the foot of the bed again.

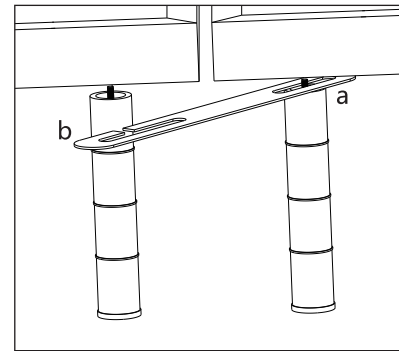

4. After installing the synchronization sheet on the back foot of the bed, repeat steps 2 and 3 to install the synchronization sheet on the leg foot and fix the two beds.

5. After the installation is complete, the synchronization function is turned on by default at the factory. If it is not turned on, please refer to the [Remote Control Button Function Description] - [Synchronization Function] in the manual to enable two-bed synchronization.

Electrical Configuration Diagram

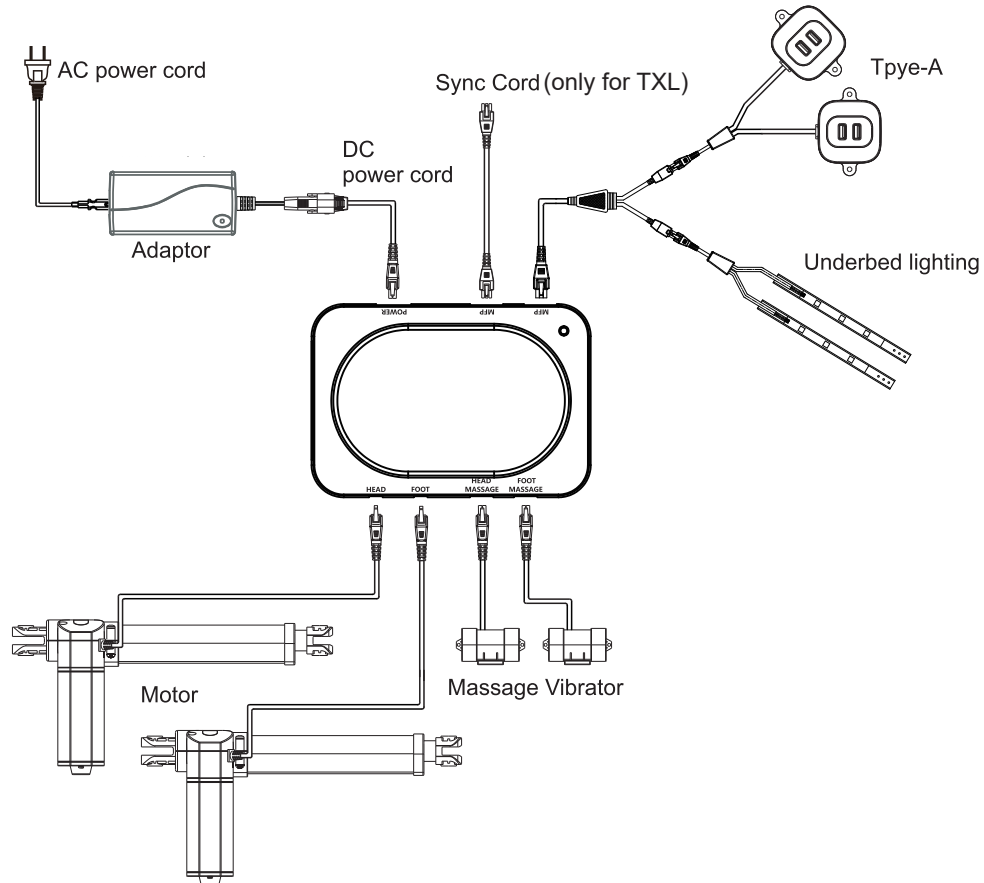

Backup Battery Device

For emergency use only, in case of a power outage. Batteries are not to be used for normal operation of the bed.
(Note: Only back down and foot down keys are allowed.)

1. Disconnect the power supply from the input power cord.

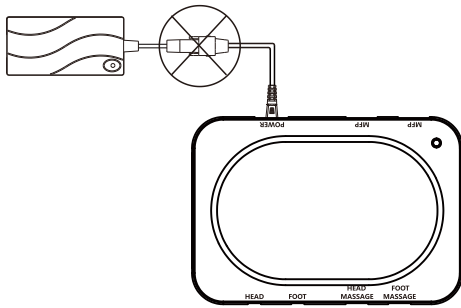

2. Connect the battery backup strap to the 2 alkaline 9V batteries. Do not mix brand name batteries.

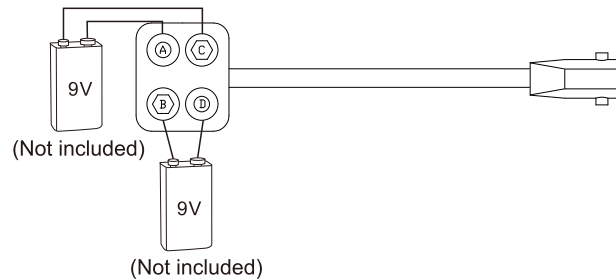

3. Connect the end of the Battery Backup Strap to the input power cord that is attached to the control box.

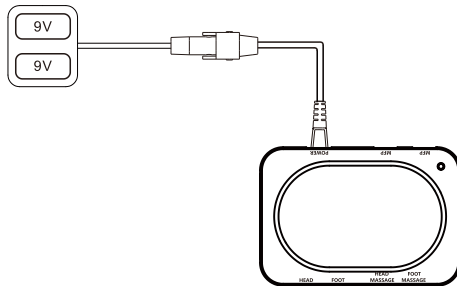

Troubleshooting

If the adjustable bed fails, please refer to the solution to the corresponding problem in the table below.

Problem	Solution
Remote control buttons are invalid.	<ol style="list-style-type: none"> 1. Make sure the batteries are charged, and replace all batteries if necessary. 2. Please refer to [Remote Control Code Pairing] instructions to re-pair the code. 3. Please confirm whether the child lock is turned on. If you need to unlock it, please follow the [Child Lock Function] to turn off the child lock.
No features or function of the adjustable bed activates.	<ol style="list-style-type: none"> 1. Please confirm whether the child lock is turned on. If you need to unlock it, please follow the [Child Lock Function] to turn off the child lock. 2. Make sure the connection between the control box and the motor is correct. 3. Make sure all power cords are properly connected. 4. Check that the power cord is plugged into a working power source or outlet.
Raise & Lower normally, but cannot return to a flat position	<ol style="list-style-type: none"> 1. The adjustable bed may be obstructed, which affect its smooth operation. Clear obstacles around and under the bed. 2. Check whether the head or foot section is too close to the wall.
Only the zero gravity button and memory position setting button cannot be used, and other function buttons can be used normally.	Use the FLAT button to flatten the bed, then use the zero gravity button or memory position button again after three seconds.
A 'click' sound is heard under the adjustable bed when raising or lowering the head section.	This is a normal phenomenon. The elevator motor makes a click sound when in use. No action is required.

Troubleshooting

If the adjustable bed fails, please refer to the solution to the corresponding problem in the table below.

Problem	Solution
The adjustable squeaks.	<ol style="list-style-type: none">1. Remove all pins, nuts, bolts or bushings.2. Lubricate it by applying grease with a cotton swab. Using a lithium or spray lubricant is recommended.3. When placing the lubricated pin, nut, bolt, or bushing back onto the adjustable bed, make sure not over tighten the nut.4. Additional solution: After completing these steps, spray the pins, nuts, bolts, bushings, or the bed joints with a lubricant.
There is a setback during the adjustment.	<ol style="list-style-type: none">1. Clean up any debris or obstacles under and around the adjustable bed.2. Make sure that the remote control is properly connected to the motors.

Attention

01. Before turning on the power, check whether the voltage is normal and whether it meets the power requirements of this product: AC100-240V, frequency 50/60HZ.
02. This product is only suitable for indoor use at home, please do not use it in other places. Do not use with oxygen or other flammable gases.
03. The place where this product is placed should not be too humid and not exposed to direct sunlight. It is necessary to maintain proper air circulation so as not to affect the normal use of this product.
04. Do not use liquids on this product, in case of spillage, unplug the power cord in a safe manner. Make sure this product is completely dry before using it again.
05. This product must be protected from moisture, water, sun, shock, falling, and trampling during movement or transportation. When moving, it should be handled with care to avoid damage.
06. Do not put sharp objects (keys, knives, nail clippers, etc.) and hard objects on this product to avoid damage.
07. Before using this product, please make sure that there are no people or pets under the bed.
08. The power cord needs to be extended from the bottom of the product and inserted into the socket to ensure that it will not be pressed and cause damage during operation. Keep cords away from moving parts of this product and heated surfaces.
09. The electronic components, metals, plastics, wires, etc. contained in the electrical box should be disposed of in accordance with the environmental regulations of various countries, and please do not dispose of them as conventional household waste.
10. When the product is in the lifting state, do not release all the weight on the head or end of the bed, so as not to damage the structure.
11. When the product is in a non-flat state, please do not perform strong impact sports such as jumping.
12. Non-professionals are not allowed to disassemble the electric bed structure and motor, so as not to cause irreversible damage to the electric bed.
13. This product has been equipped with a corresponding remote control when it leaves the factory, please operate and use it according to the instruction manual.
14. After the power supply is installed, use the remote control to check whether the functions are working normally.
15. Please do not open or tamper with the control box, motor, or remote control. Any modification will void the normal warranty.
16. The maximum load-bearing capacity of the product is shared on the bed, not on the head or feet of the bed alone; the damage caused by exceeding the load-bearing capacity cannot be guaranteed.
17. It is recommended to wear protective gear during installation and disassembly.
18. Before using the product, please check carefully to make sure that the product has been completely and correctly installed. Only the accessories provided by the manufacturer can be used for product installation. Please leave a sufficient safety gap when placing the product to avoid the risk of pinching.
19. Operate under the condition of understanding the relevant dangers. Children and those with physical and sensory defects and mentally unsound persons should use it under correct supervision and guidance. Children are not allowed to touch and play at will.
20. If the power cord is damaged, it must be replaced by the manufacturer or related professionals to avoid injury.
21. This product contains some small parts. If swallowed accidentally, there will be a suffocation hazard. Please keep these small parts away from children, and promptly dispose of all packaging materials that may cause suffocation hazards.
22. Before cleaning or repairing, the power plug must be unplugged.

Waste disposal



This marking indicates that this product should not be disposed with other household wastes. To prevent possible harm to the environment or human health from uncontrolled waste disposal, recycle it responsibly to promote the sustainable reuse of material resources. To return your used device, please use the return and collection systems or contact the retailer where the product was purchased. They can take this product for environmental safe recycling.

