

Backless Bench

Assembly Instructions

Parts List

Bench

A. Seat	1
B. Legs	2
C. Shelf	1

Hardware

1" Threaded posts	4
Bolts	4
Nuts	8
Washers	8

Thank you for your purchase!

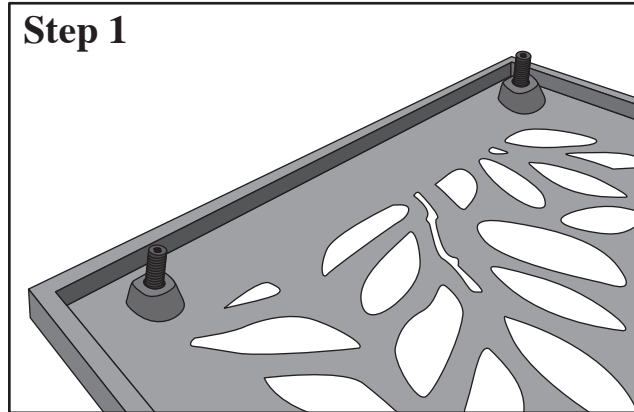

Step 1
Lay the seat on the floor face down. Insert the 1" threaded posts into the threaded holes on the underside of the bench seat. Finger tight is adequate.

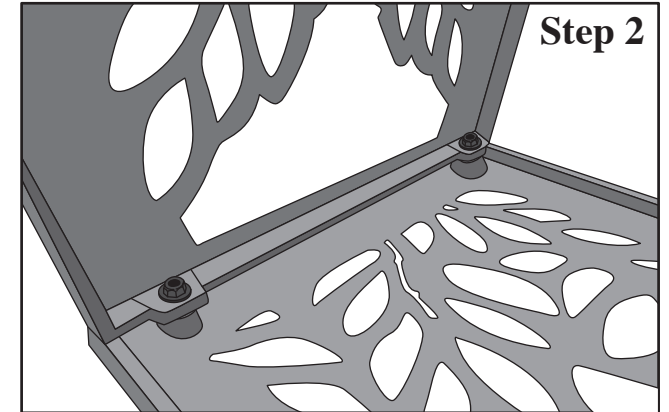

Step 2
Attach the legs by inserting the posts through the tabs in the inside of the leg. Add flat washers and lock nuts. Do not tighten completely yet.

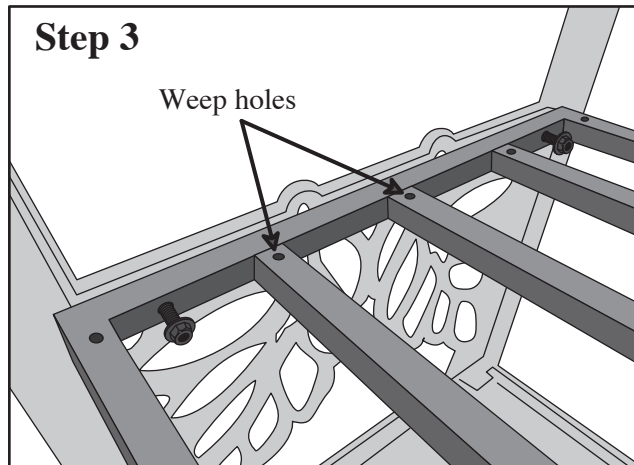

Step 3
With the unit still upside down, position the shelf to line up with the holes in the sides of the legs. Locate the weep holes in the shelf and position so that the holes are facing upward. When the bench is turned upright, these will face the floor. Insert the bolts and attach the washers and self locking nuts. Check to see that all components are aligned, then tighten these four nuts. At this point, tighten the 4 nuts connecting the legs to the seat.

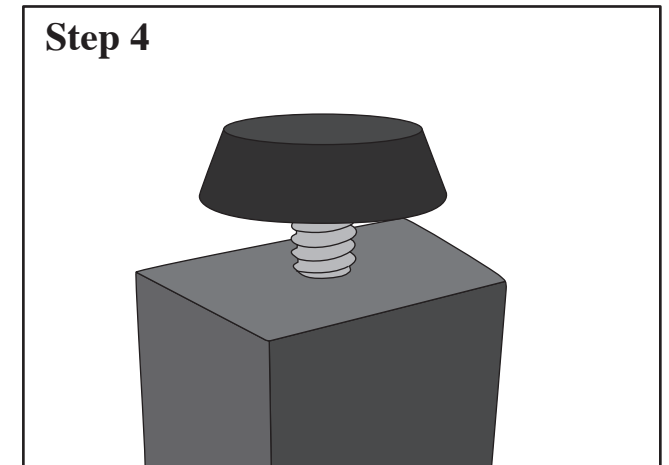

Step 4
Adjust the threaded rubber bases as needed to assure a firm, balanced base.