

ASSEMBLY INSTRUCTION

Thank you for purchasing this quality product. Be sure to check all packing material carefully for small parts which may have come loose inside the carton during shipment. Separate, identify and count all parts and hardware. Compare with the parts list to be sure all parts are present.

IMPORTANT : PLEASE READ INSTRUCTION BEFORE STARTING THE ASSEMBLY.

"DO NOT TIGHTEN SCREWS UNTIL COMPLETELY ASSEMBLED"

"DO NOT OVERTIGHT ANY HARDWARE"

WARNING : SMALL PARTS AND HARDWARE NOT FOR CHILDREN UNDER 3 YEARS. ADULT ASSEMBLY REQUIRED.

TABLE OF CONTENTS

HARDWARES LIST	PAGE 2
PARTS LIST	PAGE 3
PARTS LOCATION	PAGE 4
ASSEMBLY STEPS	PAGE 5 - 8

ASSEMBLY TOOLS REQUIRED

1.Screwdriver (not provide)



2.Hammer (not provide)

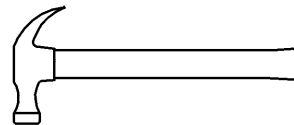



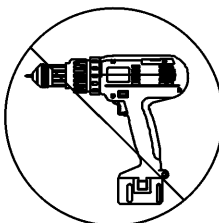



Skip the power drill this time.

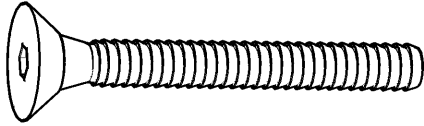
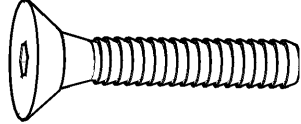
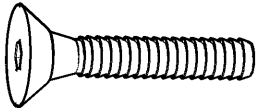

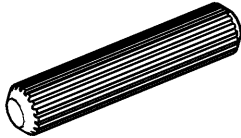

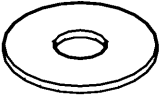



ASSEMBLY INSTRUCTION

HARDWARES LIST

ITEM	DESCRIPTION	DRAWING	QTY
A	JCBC SCREW M6 x 90 MM		22 PCS
B	JCBC SCREW M6 x 35 MM		10 PCS
C	JCBC SCREW M6 x 30 MM		3 PCS
D	BARREL NUT M6 x 13 MM		22 PCS
E	WOOD DOWEL 10 x 40 MM		22 PCS
F	CSK SCREW M4 x 25 MM		8 PCS
G	M4 ALLEN KEY		1 PC
H	M6x19 x 1.0mm FLAT WASHER		10 PCS
I	M6x12mm SPRING WASHER		10 PCS

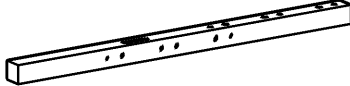
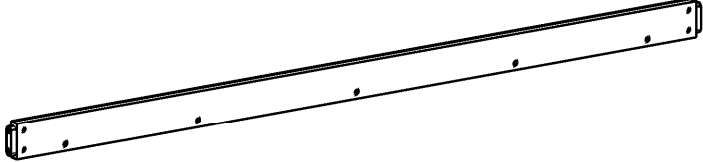
ASSEMBLY INSTRUCTION

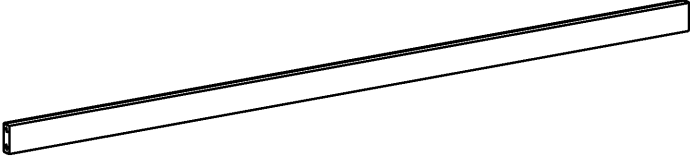
PARTS LIST

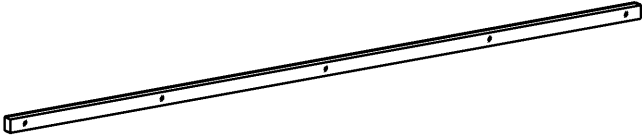
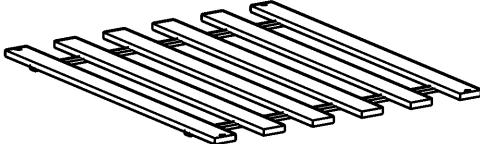
ITEM	DESCRIPTION	DRAWING	QTY
1	FRONT LEG (L)		1 PC
2	FRONT LEG (R)		1 PC
3	BACK LEG (L)		1 PC
4	BACK LEG (R)		1 PC
5	FRONT / BACK RAIL		2 PCS
6	SIDE RAIL		4 PCS
7	SIDE PANEL		2 PCS
8	BACK PANEL		3 PCS
9	BACK PANEL SUPPORT		1 PC
10	FRONT / BACK RAIL SUPPORT		2 PCS
11	SLAT		2 SET

ASSEMBLY INSTRUCTION

PARTS LOCATION

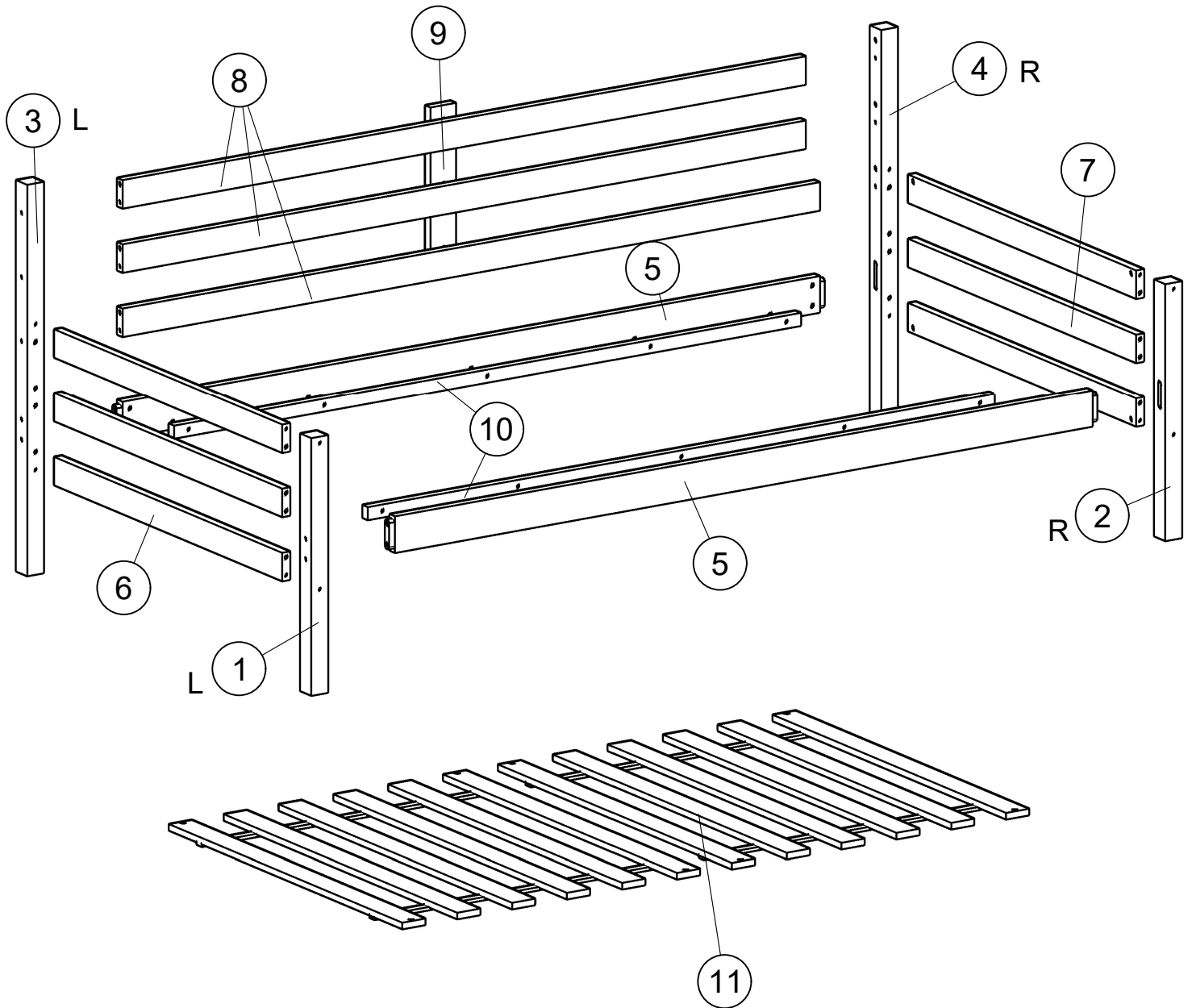

ASSEMBLY INSTRUCTION

STEP 1

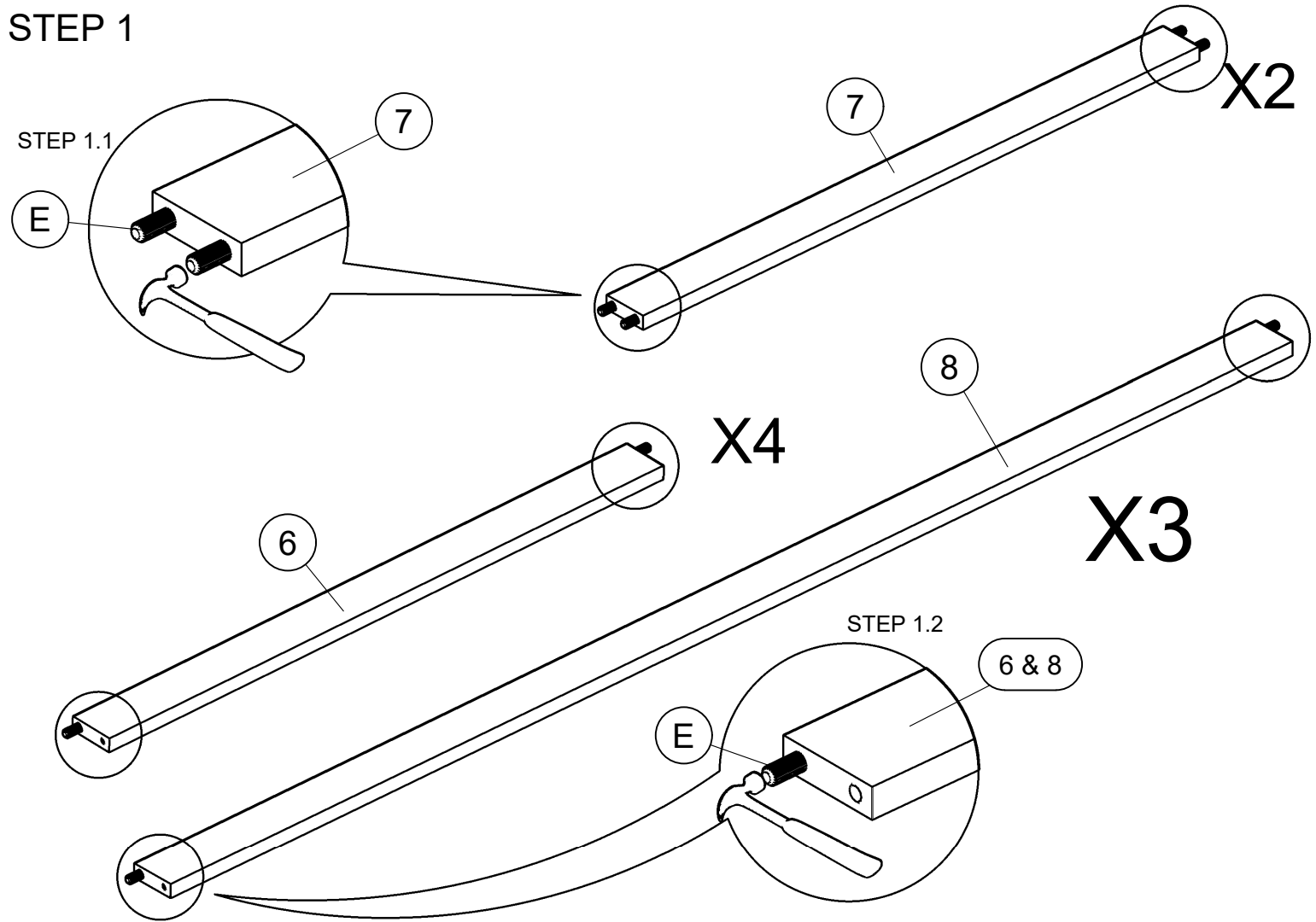

STEP 2

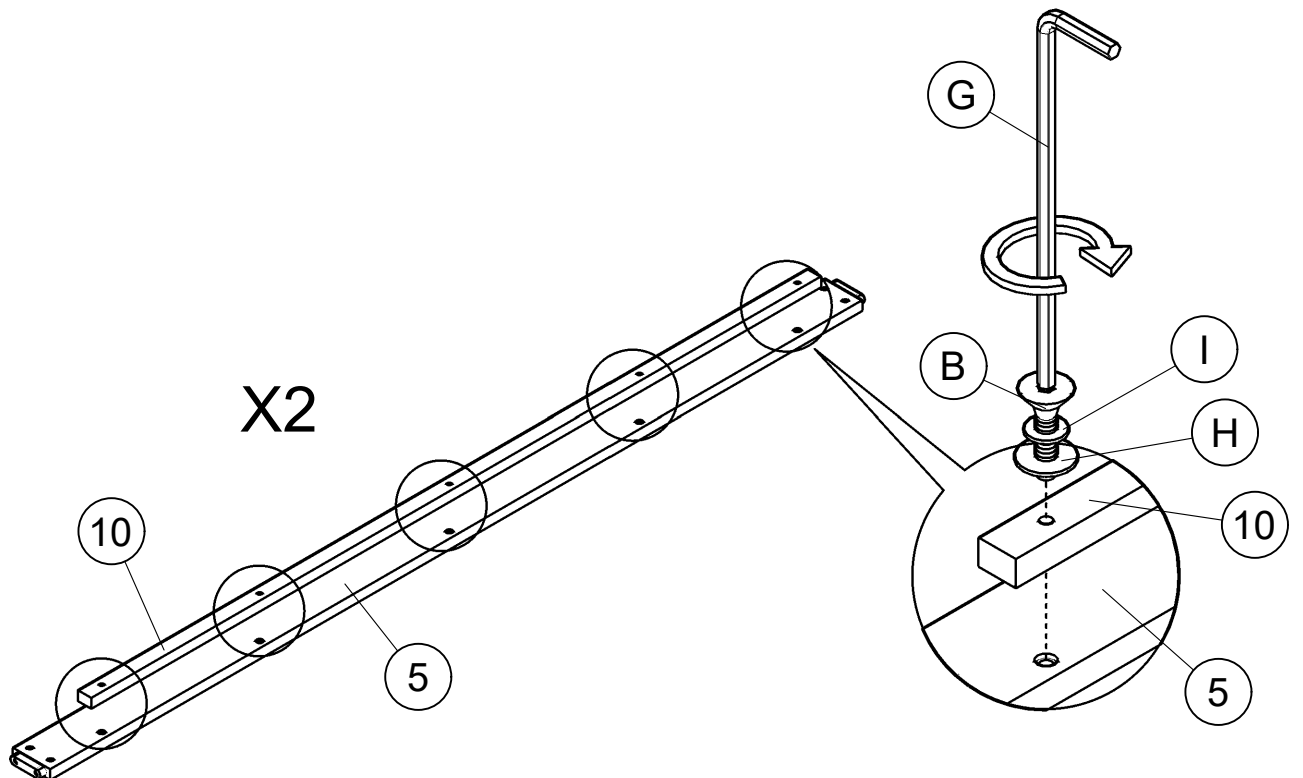

ASSEMBLY INSTRUCTION

STEP 3

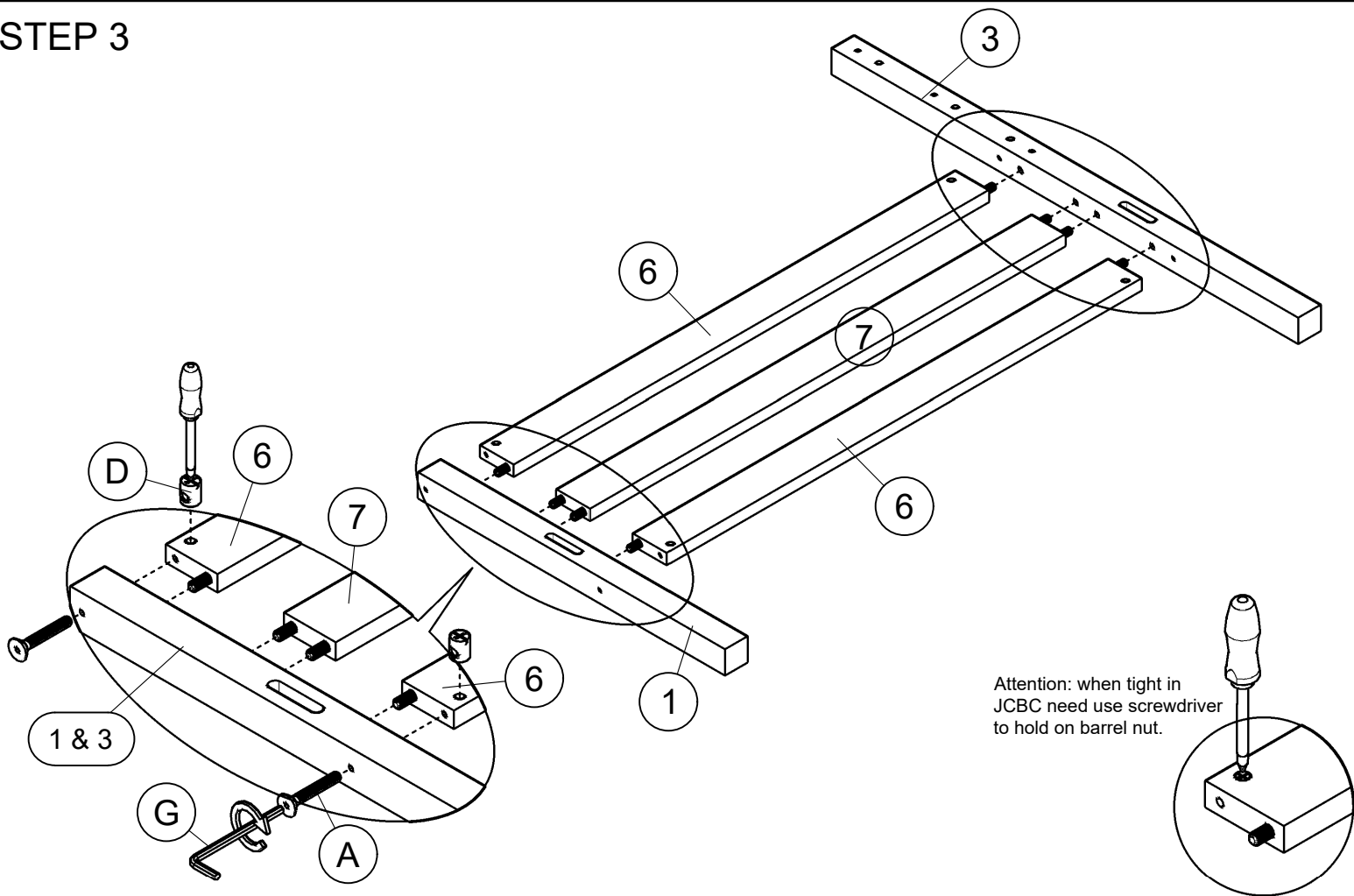

STEP 4

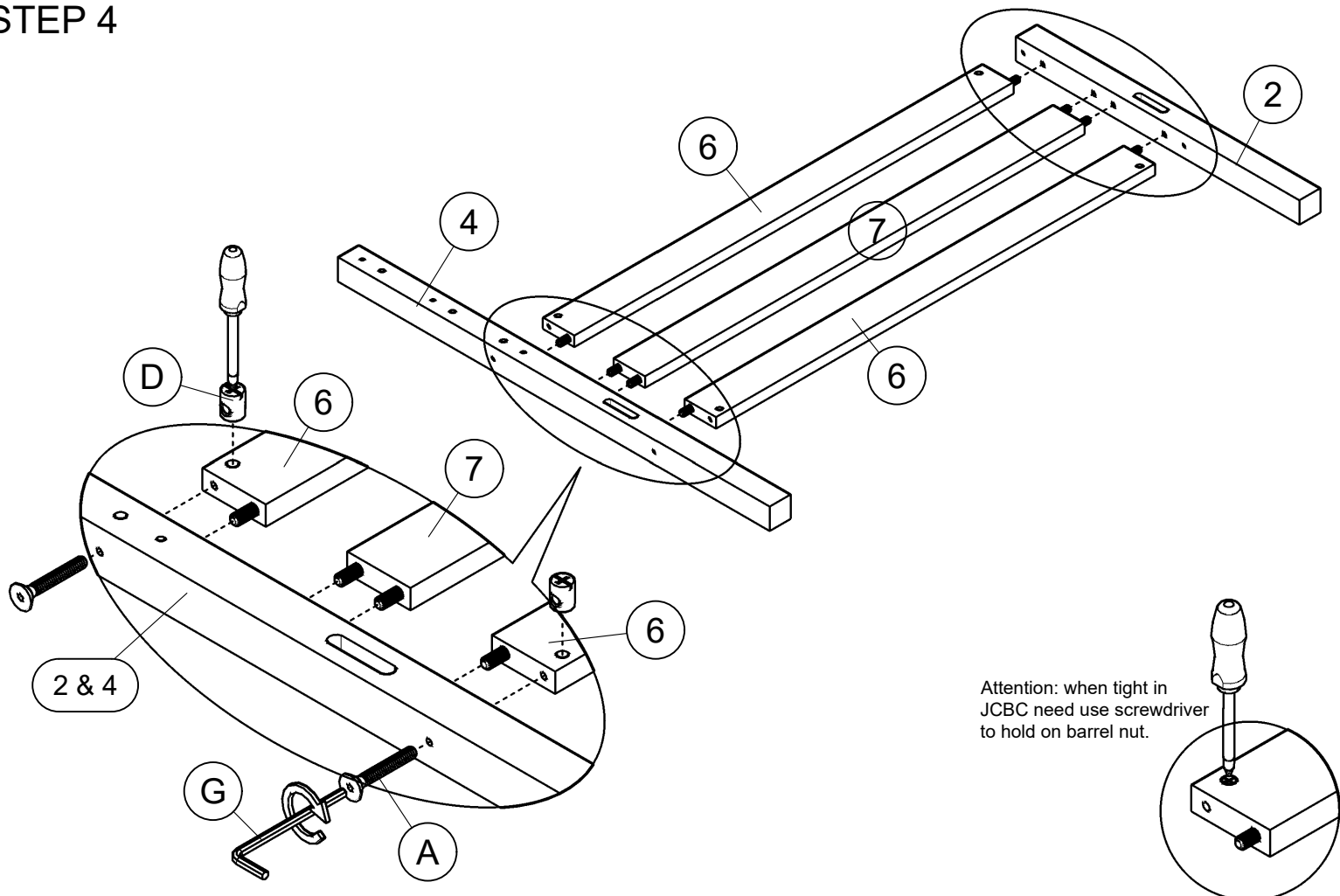

ASSEMBLY INSTRUCTION

STEP 5

STEP 5.2

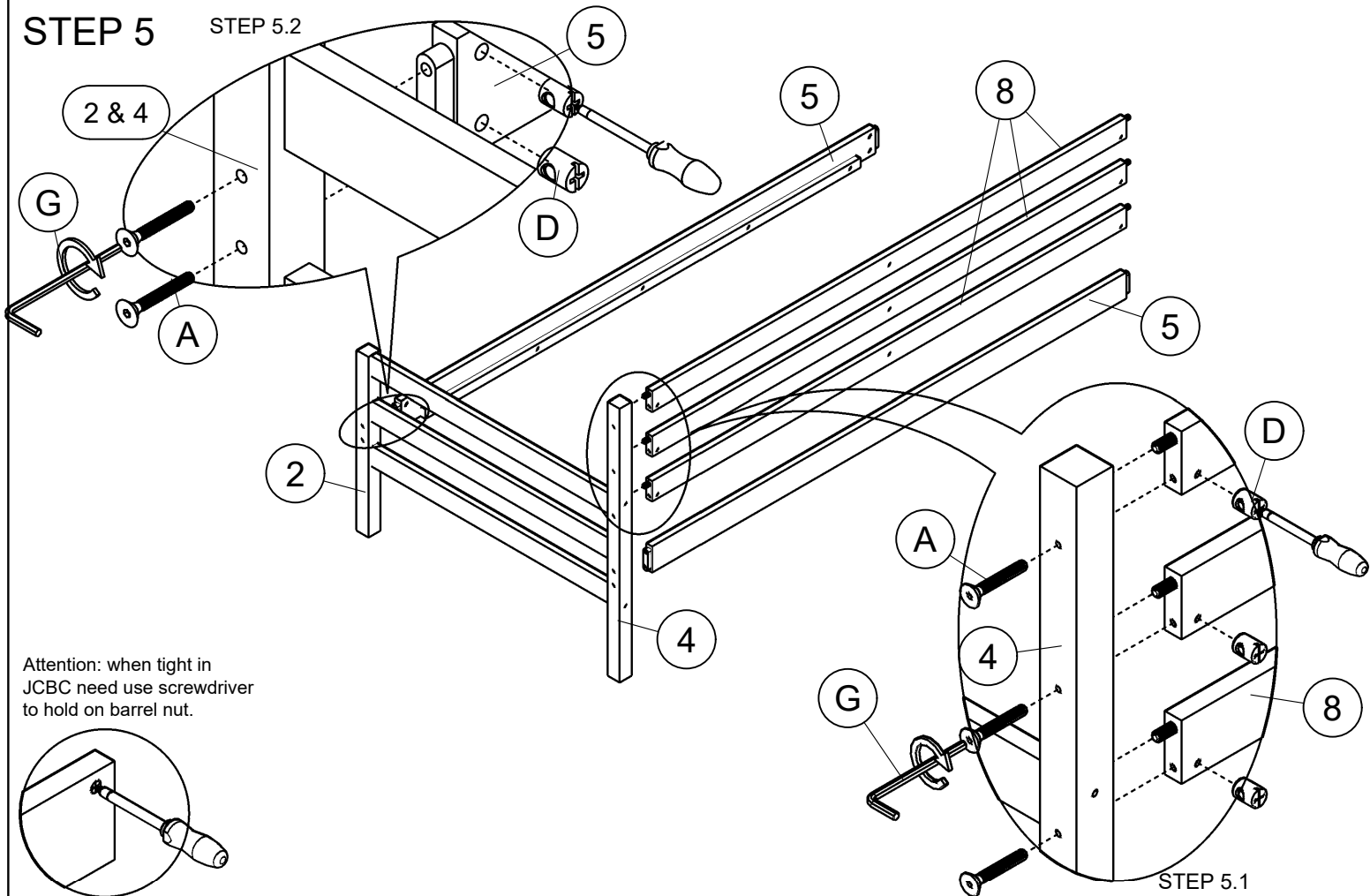

STEP 6

STEP 6.1

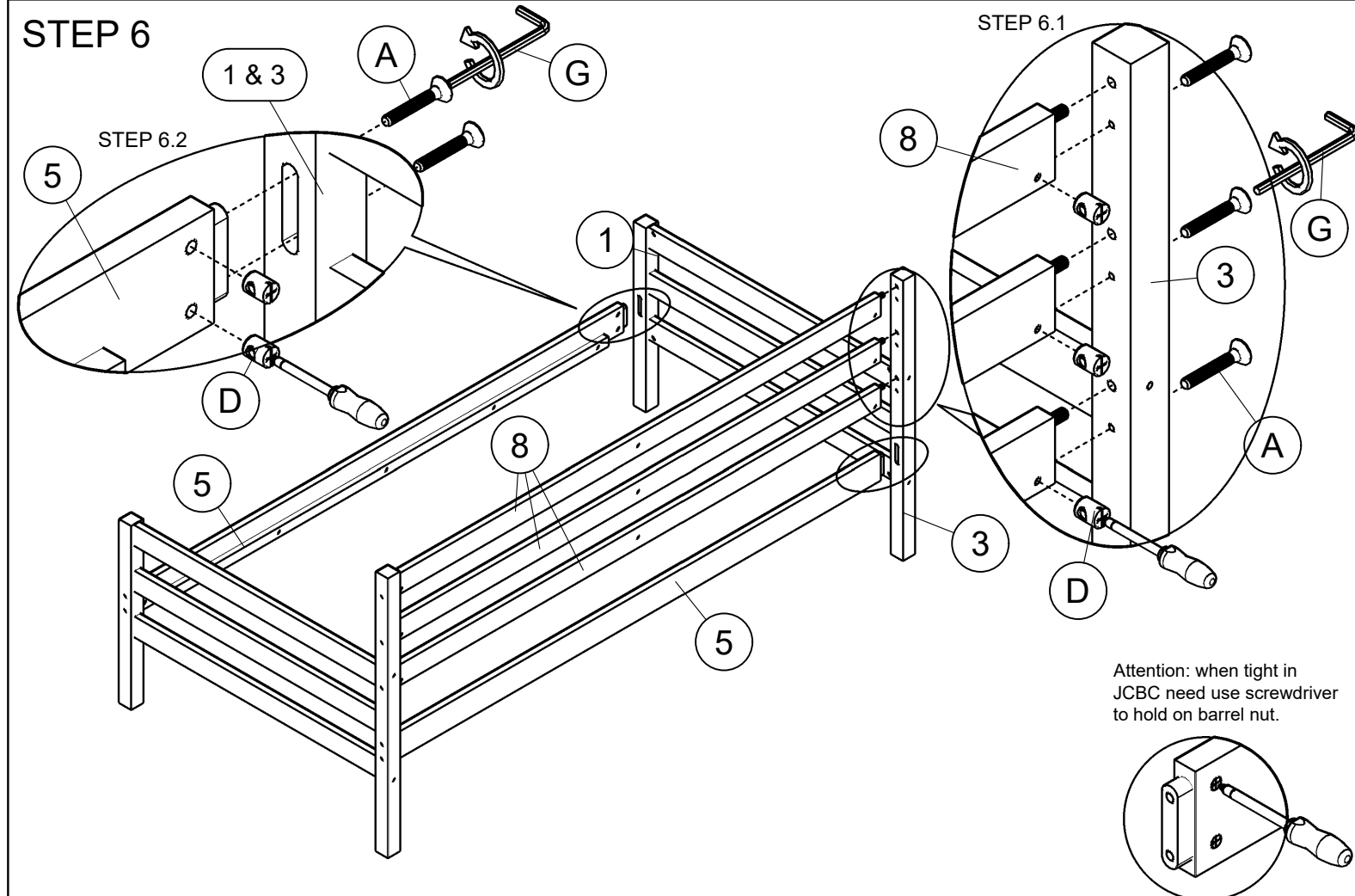

ASSEMBLY INSTRUCTION

STEP 7

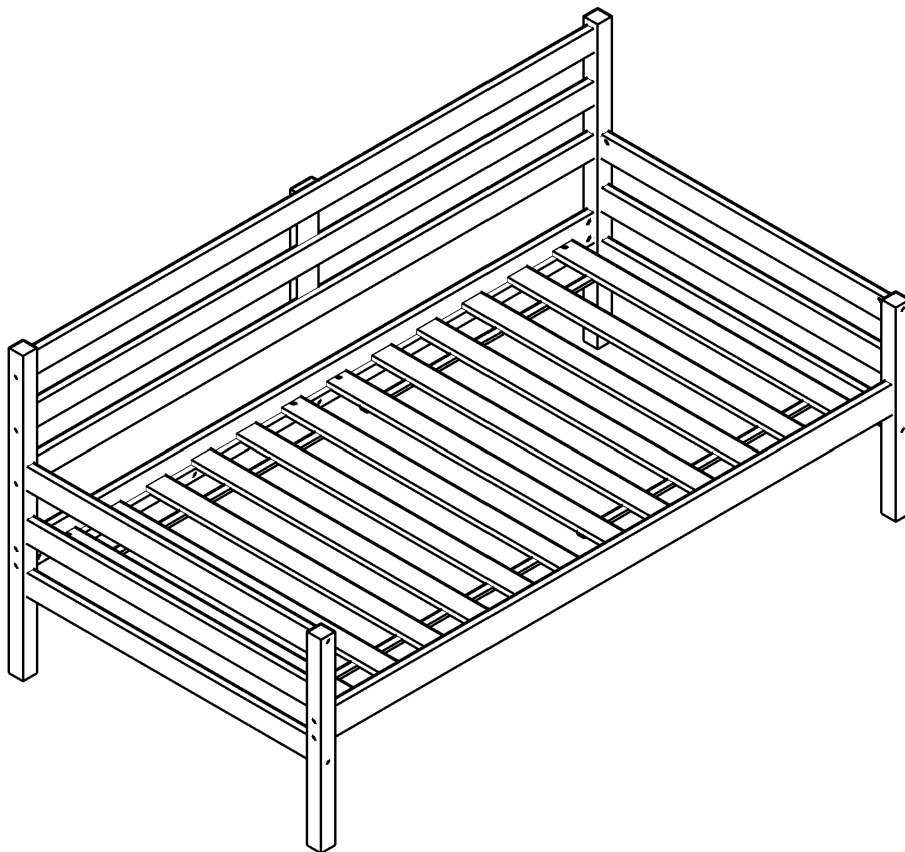
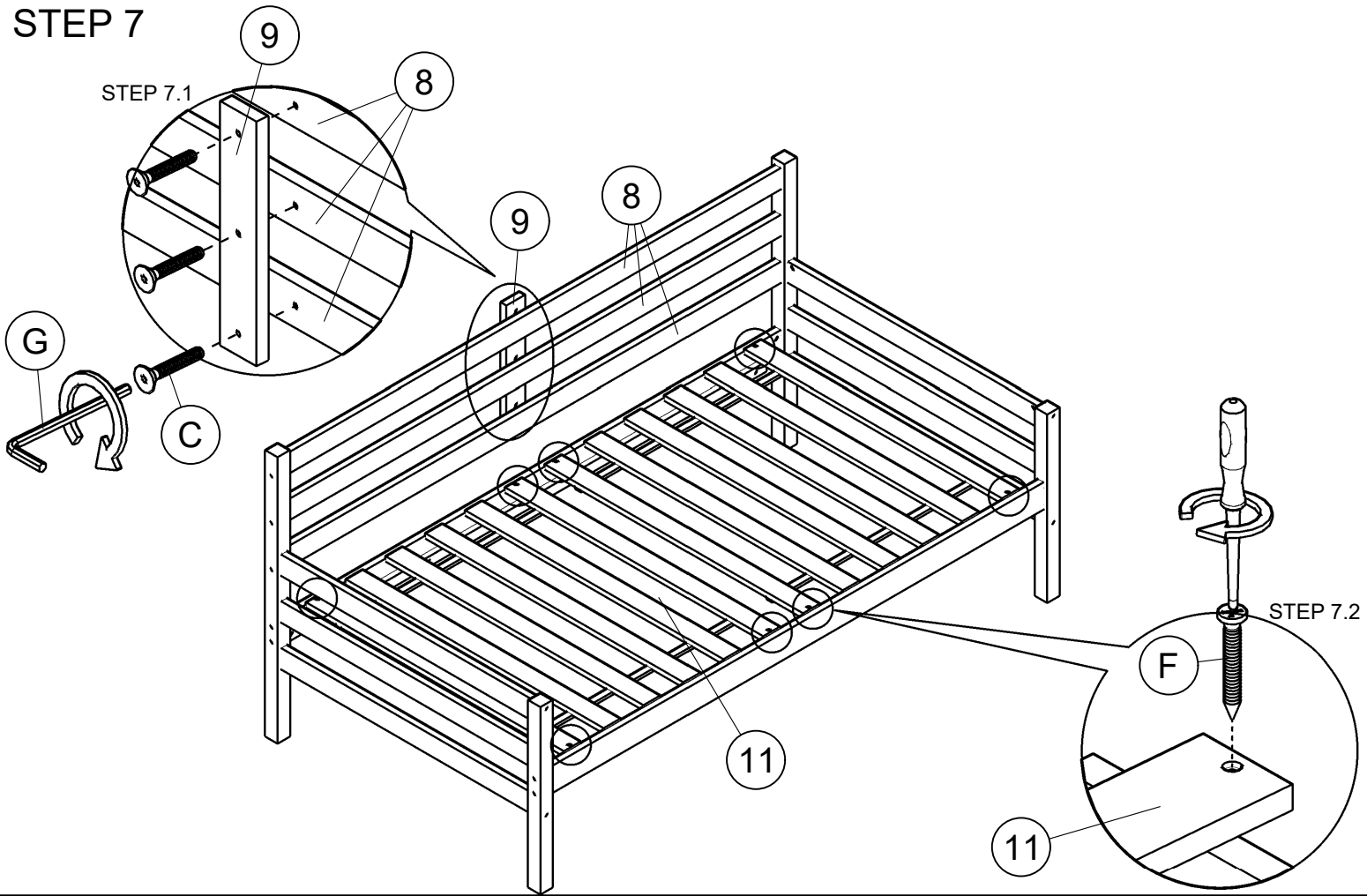

**ASSEMBLY
COMPLETE**