

# ASSEMBLY INSTRUCTIONS

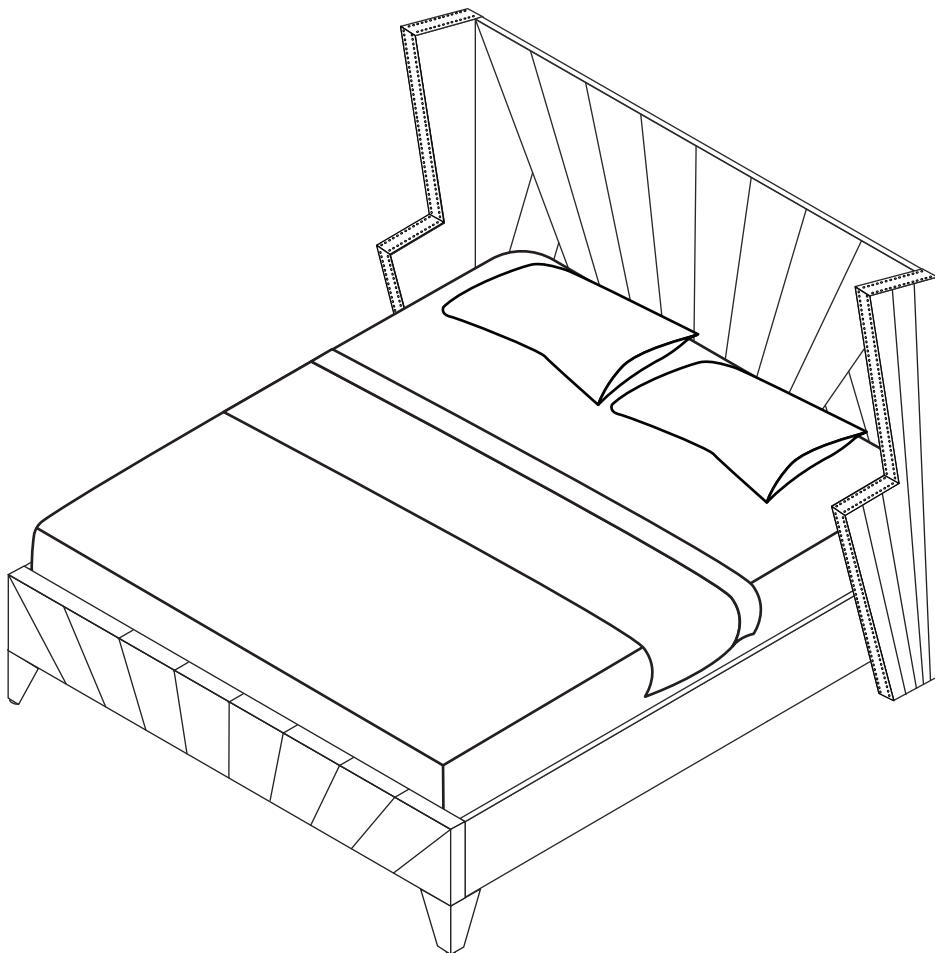

## TOOLS REQUIRED



**Allen Wrench**

(Included)



**Philips  
Screwdriver**

(Not Included)



**2 - People  
Recommended**

## ASSEMBLY RATING



EASY → DIFFICULT

The Assembly Rating is a 5-point system showing the level of effort needed to assemble a specific product.



## **CHECK BEFORE STARTING**

### **Are you missing anything?**

Double-check all parts, hardware and accessories listed on Page 6 are accounted for.

### **Check out our Quick Tips!**

We recommend reviewing the pre-assembly handouts. Even experts need a refresher now and then!

### **Should we send any replacements?**

Are there any irregularities or flaws in the parts? We can send replacements!

### **Prep Time!**

Please review the assembly instructions and all diagrams prior to assembling. Arrange parts as recommended on Page 7 and group identical hardware together to make assembling easier.

# PRE ASSEMBLY INTRODUCTION

We understand building ready-to-assemble furniture can be a challenging experience for some. To help avoid confusion, we have provided some helpful tips that may speed up the process.

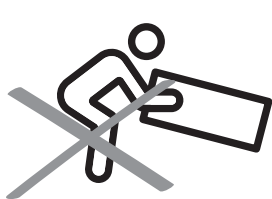

## Teamwork

ALWAYS have at least two people to help with transporting and assembling the product to avoid potential injury and/or damage.

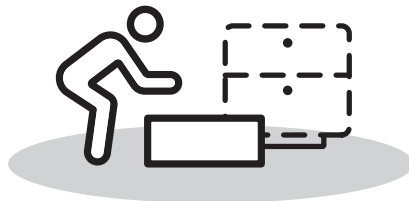
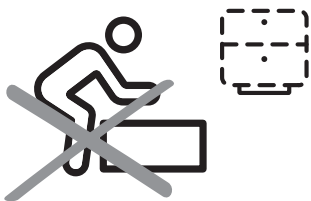

## Suitable Location

Assembling near the area of the intended location is highly recommended.



## Sufficient Space

Make sure you have enough space to move around during the assembly.

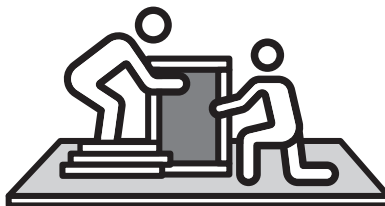

## Avoid Scratches

Use cardboard, blankets or a carpeted area while assembling furniture to prevent scratches.

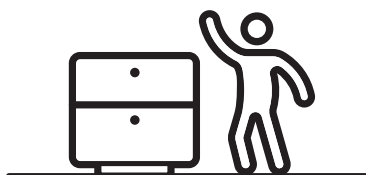
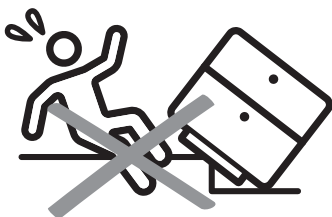

## Flat Surface

Make sure the furniture rests on a flat and level surface with each leg evenly touching the floor.

# ASSEMBLY AND CARE ADVICE



**FAILURE TO FOLLOW THE GUIDELINES BELOW MAY RESULT IN INJURY AND/OR PROPERTY DAMAGE.**



Position each part correctly and insert screws or bolts into their respective holes.

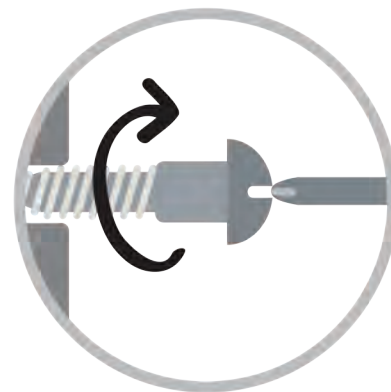

Turn clockwise to tighten and only tighten when step is completed or when instructed to do so.



Use the appropriate hand tools or power tools for assembly. Select steps, such as tightening screws and/or bolts, may require hand tools to avoid causing damage during assembly.



Save the instructions and store any supplied tools for later maintenance.



After two weeks, check and tighten any loose hardware and repeat again every six months thereafter.

**IT IS THE USER'S RESPONSIBILITY TO MAINTAIN THE FURNITURE. THE HARDWARE MAY LOOSEN OVER TIME AND MAY CAUSE THE FURNITURE TO BE WOBBLY AND UNABLE TO SUPPORT ITS INTENDED WEIGHT CAPACITY. THIS MAY LEAD TO COLLAPSE AND MAY CAUSE SERIOUS INJURY.**

# EASTERN KING BED CALIFORNIA KING BED

MODEL CM7164EK / CK

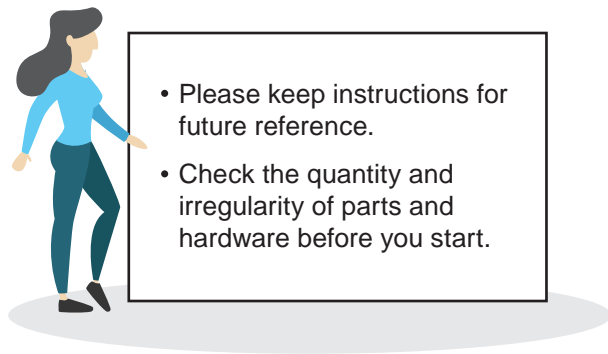

## PARTS

#1 1pc

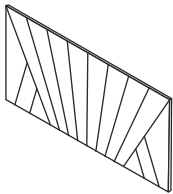

Headboard

#2 2pcs

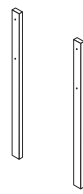

Headboard Leg Support

#3 2pcs

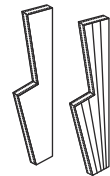

Ear Panel  
(L & R)

#4 2pcs

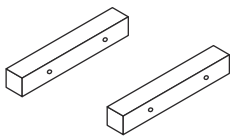

Ear Panel Support

#5 2pcs

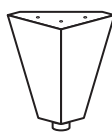

Bed Leg

#6 5pcs

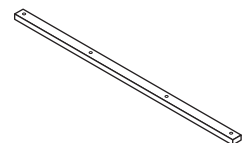

Slat

#7 10pcs



Leg Support  
(30 x 30 x 125mm)

#8 1pcs

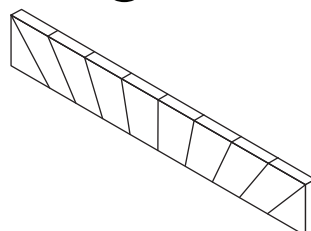

Footboard

#9 2pcs

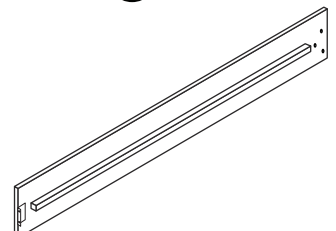

Side Rail  
(L & R)

## HARDWARE

#A 1pc



Allen Key M4 with ball

#B 4pcs



JCBC Bolt M6 x 30mm

#C 22pcs



JCBC Bolt M6 x 45mm

#D 6pcs



JCBC Bolt M6 x 60mm

#E 2pcs



CSK Screw M4 x 20mm

#F 10pcs



CSK Screw M4 x 32mm

#G 4pcs



CSK Screw M4 x 45mm

#H 10pcs



Adjuster

#I 22pcs



Spring Washer M6

#J 2pcs



Flat Washer Small M6 x 13 x 1.0

#K 22pcs



















Flat Washer Medium M7 x 19 x 2.0

#L 22pcs

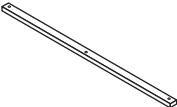

Flat Washer Large 3/8 x 25 x 1.0

## CM7164EK & CK is packed in 3 cases

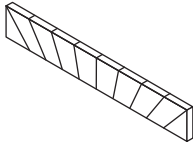
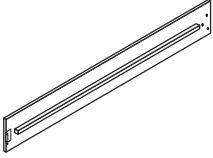
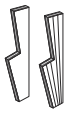
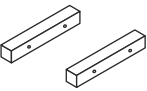
Carton	Designation	Part		Hardware
CM7164EK - 1 & CM7164CK - 1	Headboard	#1	 1pc	
	Headboard Leg Support	#2	 2pcs	
CM7164EK - 2 & CM7164CK - 2	Bed Leg	#5	 2pcs	 #A x 1pc  #B x 4pcs  #C x 22pcs  #D x 6pcs  #E x 2pcs  #F x 10pcs  #G x 4pcs  #H x 10pcs  #I x 22pcs  #J x 2pcs  #K x 22pcs  #L x 22pcs
	Slat	#6	 5pcs	
	Leg Support	#7	 10pcs	
	Footboard	#8	 1pc	
	Side Rail	#9	 2pcs	
	Ear Panel	#3	 2pcs	
CM7164EK - 3 & CM7164CK - 3	Ear Panel Support	#4	 2pcs	

# ASSEMBLY INSTRUCTIONS

# 1

Part #1 x1pc

Part #2 x2pc

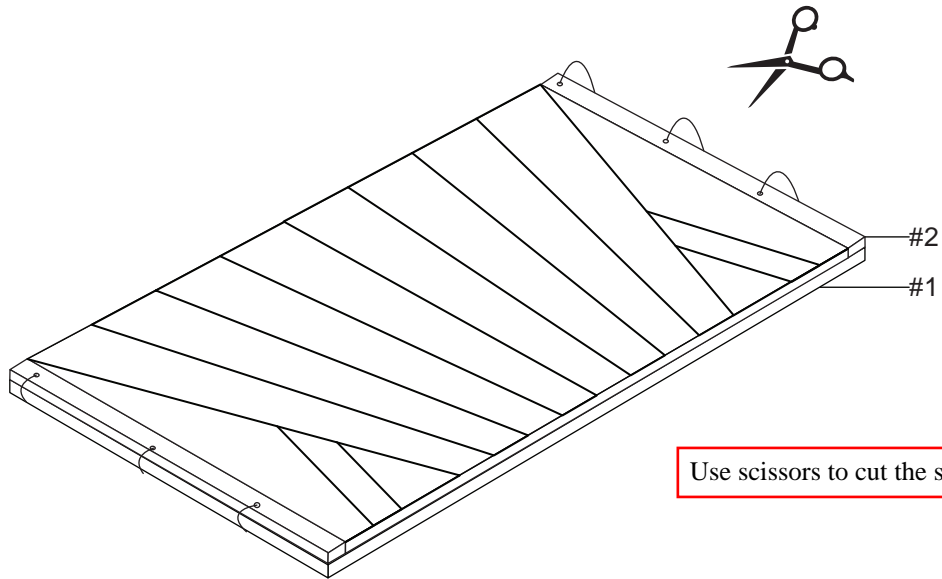

Use scissors to cut the strap off.

# 2

Part #1 x1pc

Part #2 x2pcs

Hardware #A x1pc

Hardware #C x4pcs

Hardware #I x4pcs

Hardware #K x4pcs

Hardware #L x4pcs

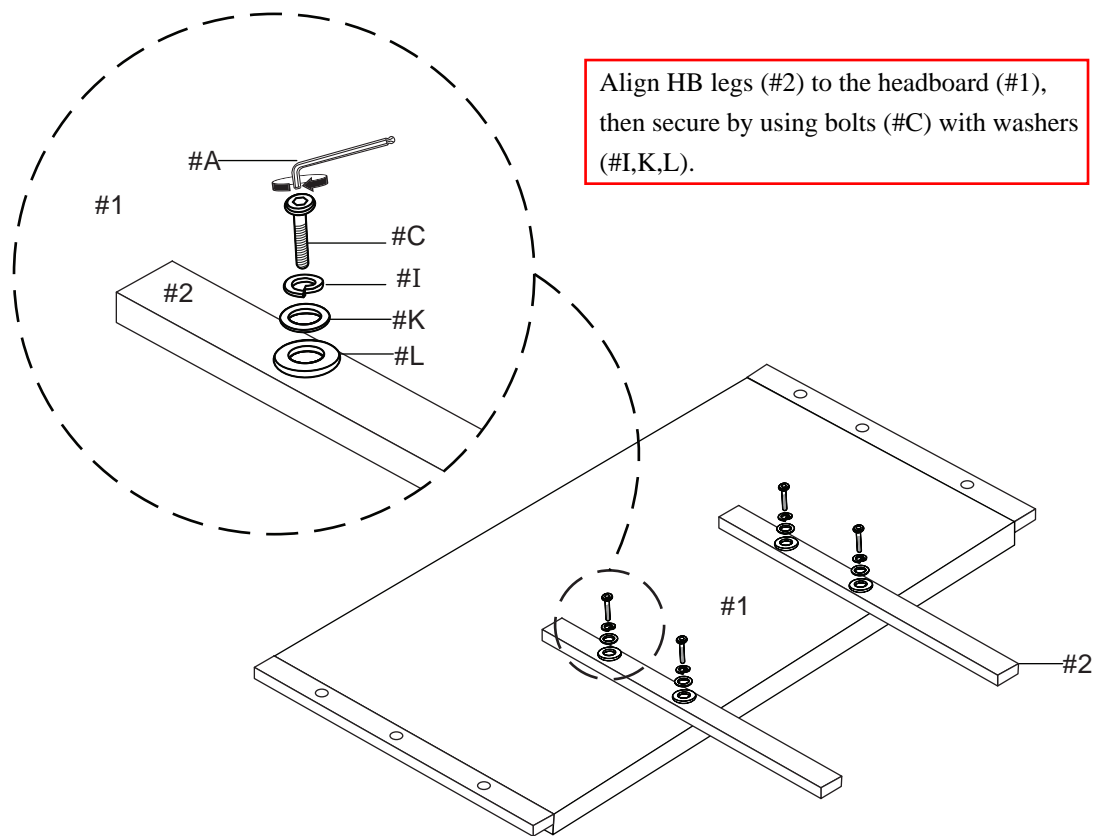

Align HB legs (#2) to the headboard (#1), then secure by using bolts (#C) with washers (#I,K,L).

# ASSEMBLY INSTRUCTIONS

## 3

Part (#3) x2pcs

Hardware (#G) x4pcs

Align support (#4) to the ear panel (#3), then secure by using screws (#G).

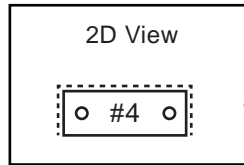
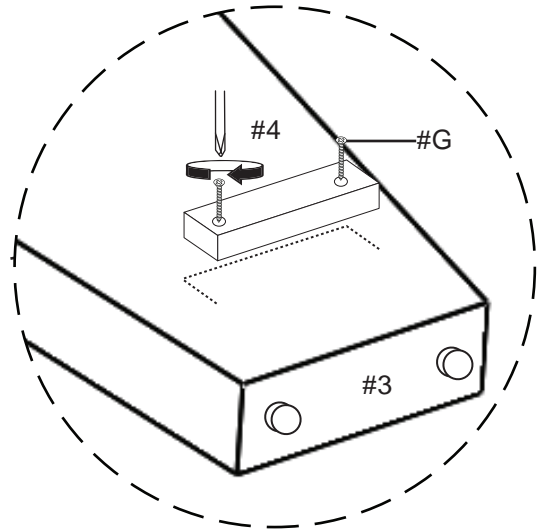
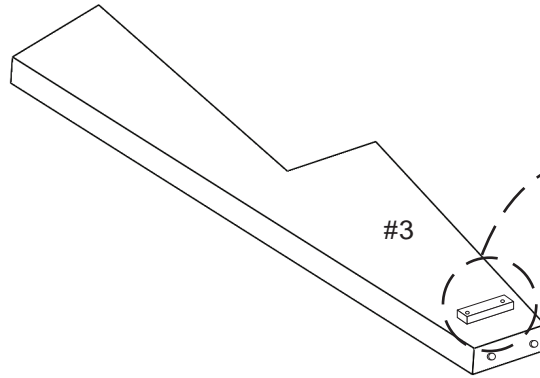

Marking Line Above part #4

## 4

Part (#1) x1pc

Part (#2) x2pcs

Part (#3) x2pcs

Hardware (#A) x1pc

Hardware (#C) x6pcs

Hardware (#I) x6pcs

Hardware (#K) x6pcs

Hardware (#L) x6pcs

Align ears (#3) to the headboard (#1), then secure by using bolts (#C) with washers (#I,K,L).

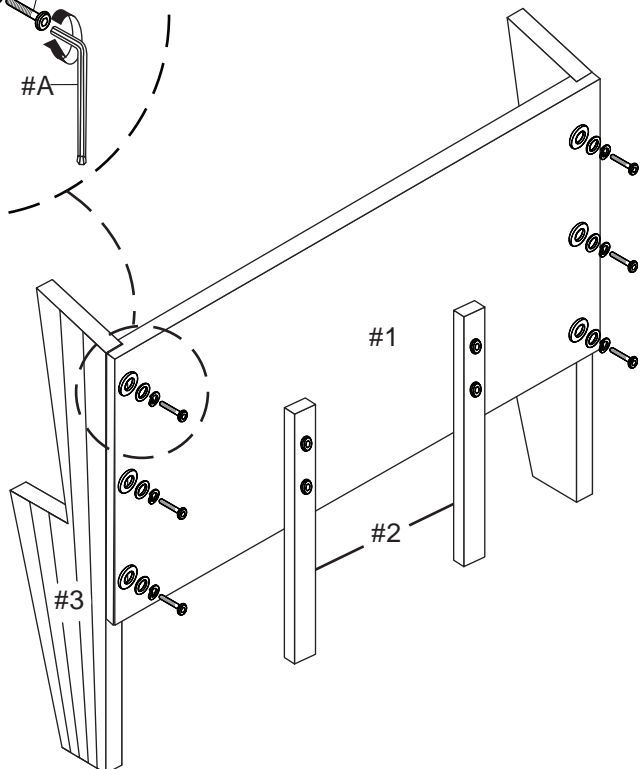
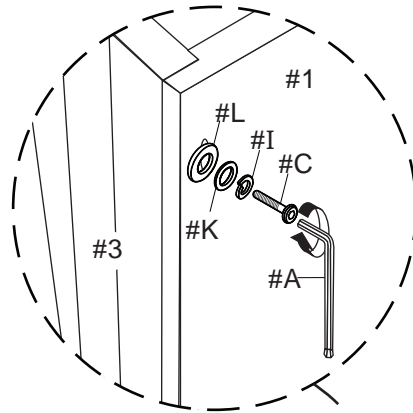

# ASSEMBLY INSTRUCTIONS

## 5

- Part (#8) x1pc
- Part (#5) x2pcs
- Hardware (#A) x1pc
- Hardware (#C) x2pcs
- Hardware (#E) x2pcs
- Hardware (#I) x2pcs
- Hardware (#J) x2pcs
- Hardware (#K) x2pcs
- Hardware (#L) x2pcs

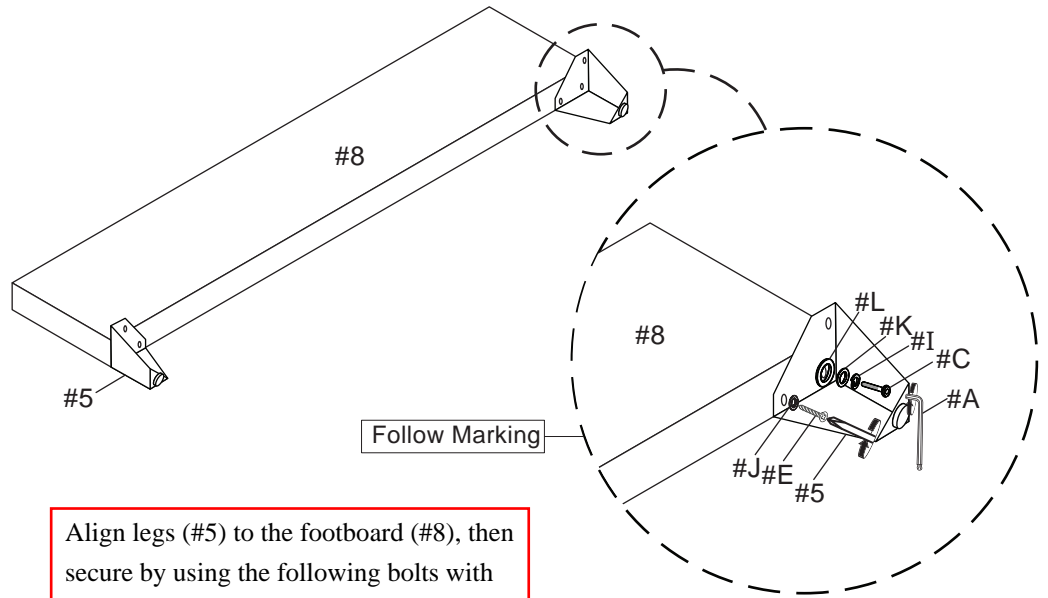

Align legs (#5) to the footboard (#8), then secure by using the following bolts with washers in the diagram below.

## 6

- Part (#8) x1pc
- Part (#9) x2pcs
- Hardware (#A) x1pc
- Hardware (#B) x4pcs
- Hardware (#I) x4pcs
- Hardware (#K) x4pcs
- Hardware (#L) x4pcs

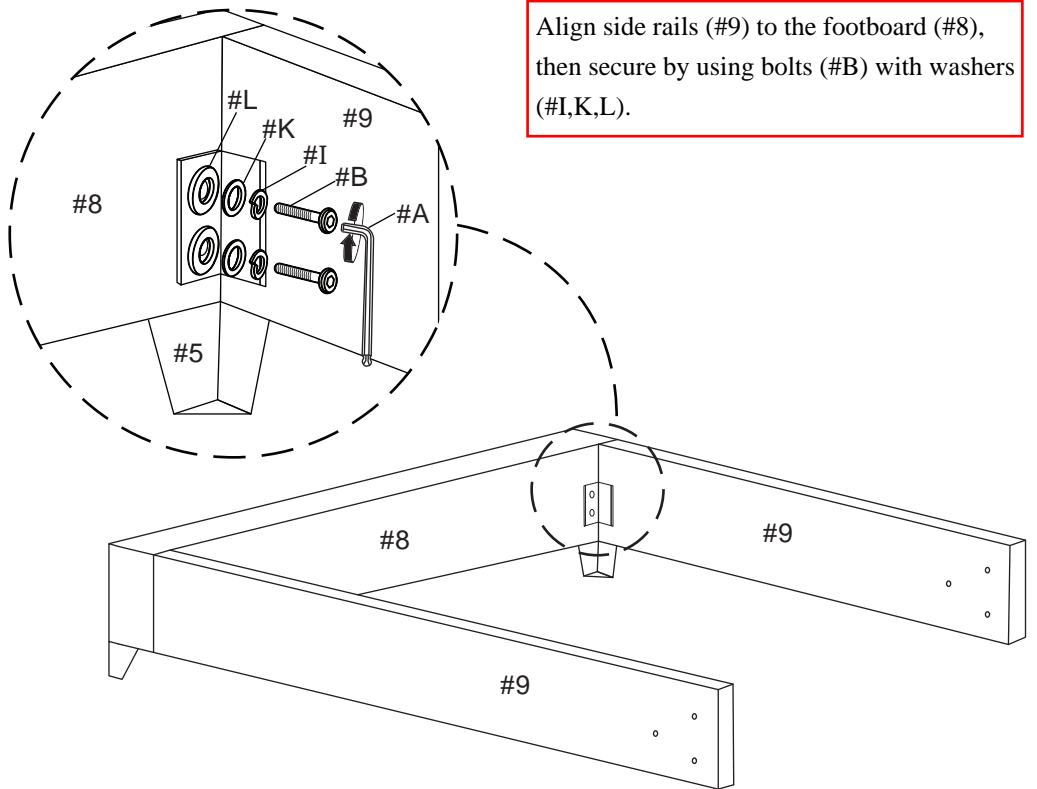

# ASSEMBLY INSTRUCTIONS

## 7

- Part #3 x2pcs
- Part #9 x2pcs
- Hardware #A x1pc
- Hardware #D x6pcs
- Hardware #I x6pcs
- Hardware #K x6pcs
- Hardware #L x6pcs

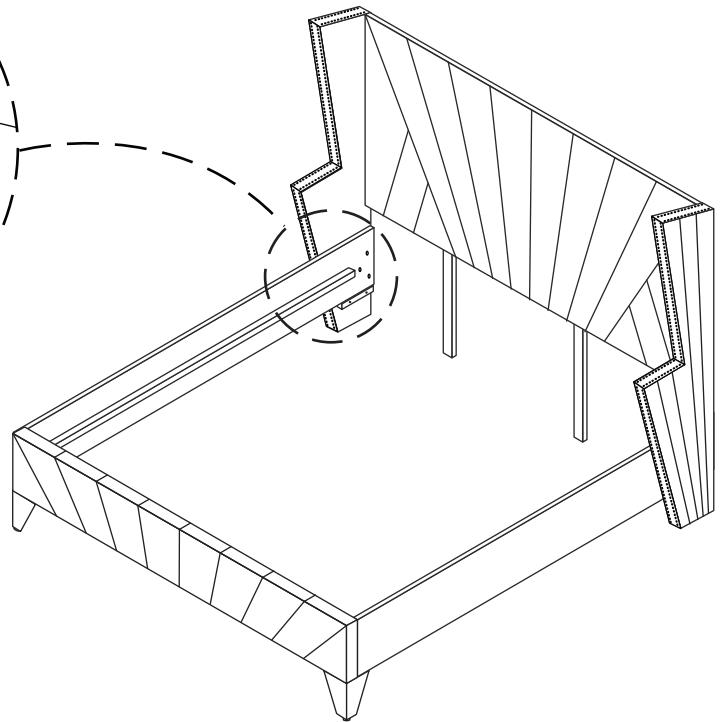
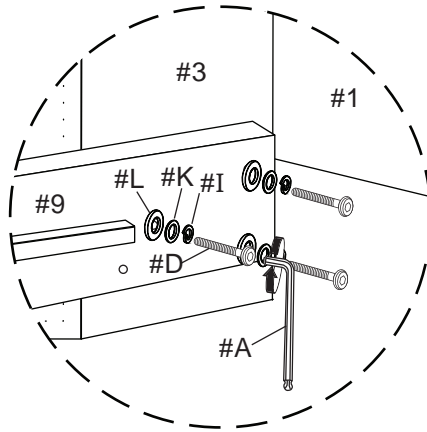

Align side rails (#9) to the ears (#3), then secure by using bolts (#D) with washers (#I,K,L).

## 8

Align slat (#6) to the side rails (#9), then secure by using screws (#F)

- Part #6 x5pcs
- Part #7 x10pcs
- Hardware #A x1pc
- Hardware #C x10pcs
- Hardware #F x10pcs
- Hardware #H x10pcs

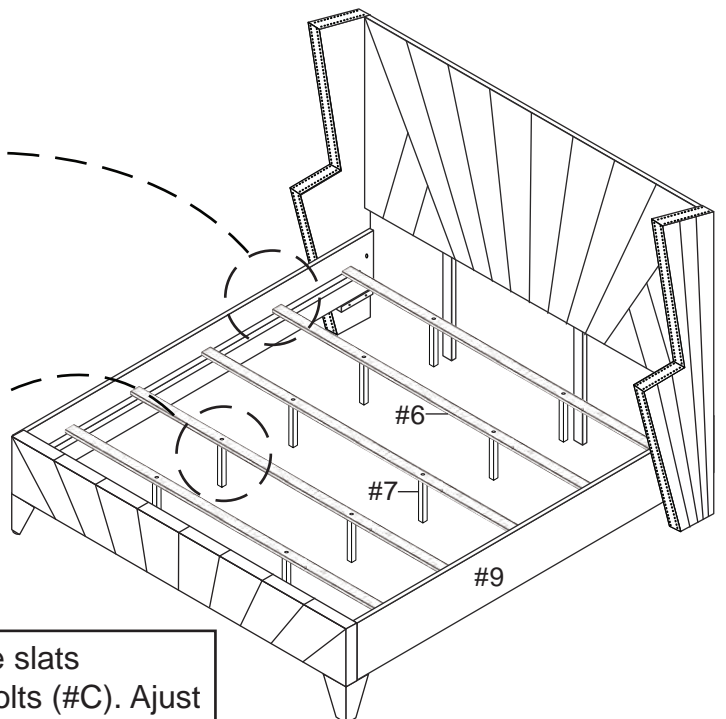
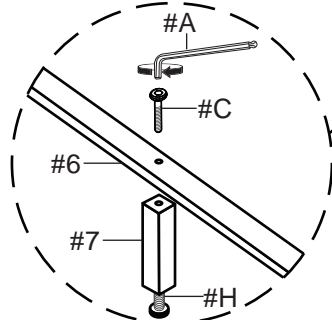
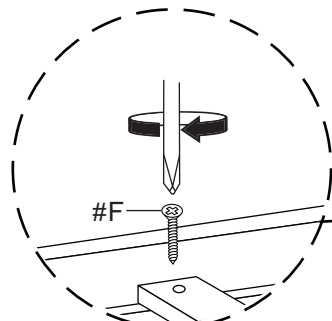

Align support legs (#7) to the slats (#6), then secure by using bolts (#C). Adjust levelers (#H) according to ground level.

### ASSEMBLY COMPLETED



Please ensure the furniture rests on an even and flat surface. If the product wobbles or feels loose, double-check all bolts and/or screws are properly tightened and secured.

#### Keep this handy!

Please retain this instruction manual and any order-related information for future reference.

#### Lift, don't drag!

To avoid damage to product please always LIFT the product when transporting or adjusting the placement.