

USER MANUAL



Functions

◆ NECK PART:

Adjustable pillow.

◆ BACK PART:

- 1.Eight kneading heads working .
- 2.Infrared heating.

◆ HIP PART:

Two vibration intensities supply comfortable vibration on the thighs.

◆ LEG PART:

Five angles to adjust different position for relaxing your leg.

◆ 15 mins time limited.

Controller

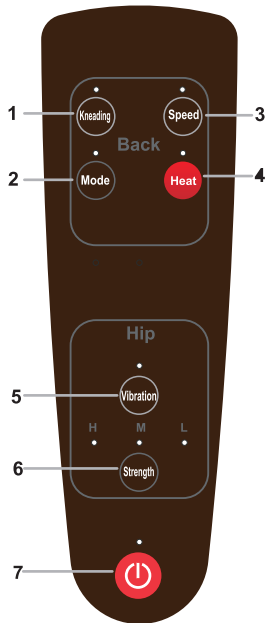

1. Back Massage Programme

Change the direction kneading heads.

2. Kneading Massage Mode

Provides 2 different massage techniques to relief sore muscles.

3. Kneading Massage Speed

Provides 3 different massage speed: fast and slow.

4. Heat Therapy

Improve metabolism rate.

5. Vibration Massage

To relax your and thighs.

6. Massage Intensity

Select your desired massage intensity levels.

7. Power ON/OFF And Auto Programme

Switch ON or OFF the machine.

Press this button by starting working automatically.

How to operate

1. Open the packing ,place the massage chair in a flat place & assemble.
2. Connect the DC with the adaptor.
3. Connect the adaptor with the power.
4. Press the button on controller to start working.

Notes

Before use	<ul style="list-style-type: none">● Please read carefully the instruction before use.
Practice	<ul style="list-style-type: none">● Working 20 minutes every day at the beginning stage and more time step by step; do not exceed 20 minutes for safety.● Could place one folded towel or blanket on back in case of too strong massage pressure.
Longer Life	<ul style="list-style-type: none">● Please let the machine be rest for 20 minutes after 40 minutes operation so to ensure of longer life of machine.
After Use	<ul style="list-style-type: none">● Please turn-off power and then pull out the plug after usage; please do pull the plug from the socket and do not pull the wire.
Place to put	<ul style="list-style-type: none">● Please do not operate the massager where with much dust, oil crust, fog.● Please do not put the massager near to electric appliance.● Please do not put the massager where under direct sunshine● Please do not use the massager where with much humidity (like hot spring, swimming pool, bathroom etc).● Please do not use the massager outdoor.● Please do not operate the massager where with fog and lack of oxygen.

Suitable for the crowd

- Those who feel uncomfortable, been operation or be injured on back, neck, please consult with doctor before using.
- Do not use within one hour after lunch/dinner.
- The following people please use the massager after consulting with doctor or specialist :
 - a) with cancer
 - b) heart disease
- Pay much attention when the massager is running, especially for patients or those without ability of operation.
- You are suggested to wear baggy clothes when using the massager; Do not use it nakedly which might cause hurt to your skin; Too thick or thin clothes or those with collar, belt or other hard objects should also be avoided because they might affect massage effects.
- Prohibit using for kids and those pregnant women

FAQ

Phenomenon	How to check	How to handle
Sounds like squeak, ping, click,	Sound is caused by motor; normal; no need to check	N/A
Noise during massager	Has it been working for a long time or continue?	Please turn off power and be rest over one hour
Feeling hot on the surface	Has the working time exceed time limit?	Please operate within time limit
No working or stop suddenly during running	1. Power off 2. Temperature protection devise	1. insert the plug and turn on the power 2. turn off power and be rest over one hour
Please consult the distributor if no use after the above handling		

DANGER

To reduce the risk of electric shock

1. Always unplug the appliance from the electrical outlet innediately after use and before cleaning.
2. Never use pins or other metallic fasteners with this appliance.
3. Keep dry-Do not operate in a water or moist condition.

Specifications

Product Name	Rocking Massage Chair
Model No.	LY-003
Voltage	12V--- 3A
Rated Power	36 W
Time Limited	15 min
Product Size	890(L) X 410(W) X 605(H)
N.W.	22 KG
G.W.	24 KG

CAUTION

- ◆ TO REDUCE THE RISK OF ELECTRIC SHOCK, DO NOT REMOVE COVER, THERE ARE NO SERVICEABLE PARTS INSIDE.
- ◆ TO REDUCE THE RISK OF FIRE OR ELECTRIC SHOCK, DO NOT EXPOSE THIS ITEM TO RAIN OR MOISTURE.



The lightning flash with arrow-head symbol within an equilateral triangle is intended to alert the user to the presence of uninsulated “dangerous voltage” within the unit’s enclosure that may be of sufficient magnitude to constitute a risk of electric shock.



The exclamation point within an equilateral triangle is intended to alert the user to the presence of important operating and maintenance (servicing) instructions in the literature accompanying the unit.

ASSEMBLY INSTRUCTIONS

►STEP1

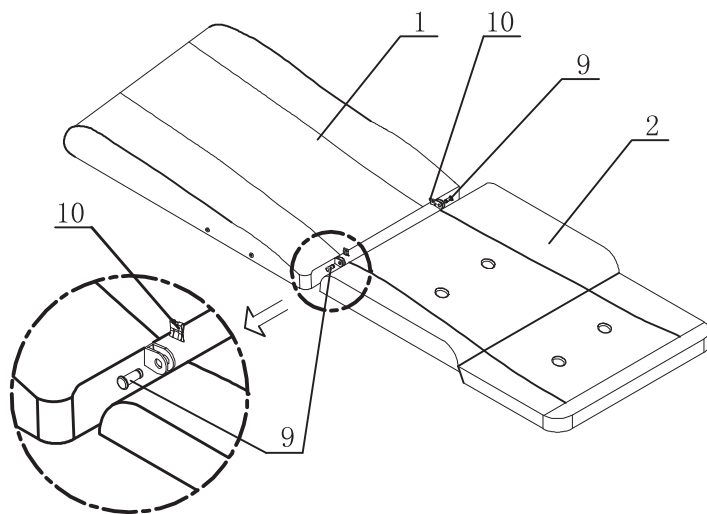

No.	Name	Q' TY
1	Backrest	1
2	Cushion	1
9	pin	2
10	leaf spring	2

►STEP2

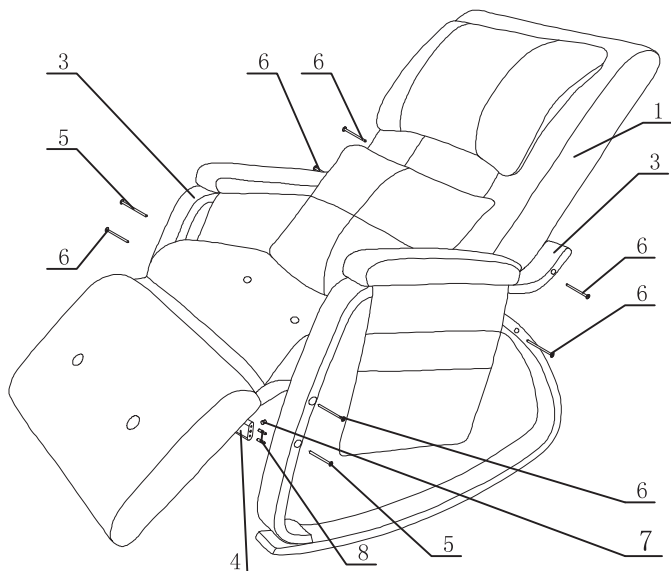

No.	Name	Q' TY
1	Backrest	1
2	Cushion	1
3	Left and right armrests	2
4	Connecting beams	1
5	Screw M6x105	2
6	Screw M6x90	6
7	Round nut M6	2
8	Wooden dowel	4

Rocking Massage Chair

Model:LY-003

Many thanks for purchasing our massage items. Before using this machine, please read this manual carefully to make sure fully understand the exact method of using, especially the points for attention. Please keep this manual carefully for your reference!