

ASSEMBLY INSTRUCTIONS

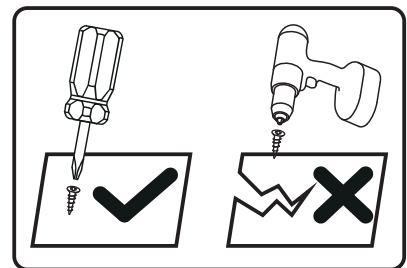
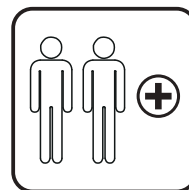
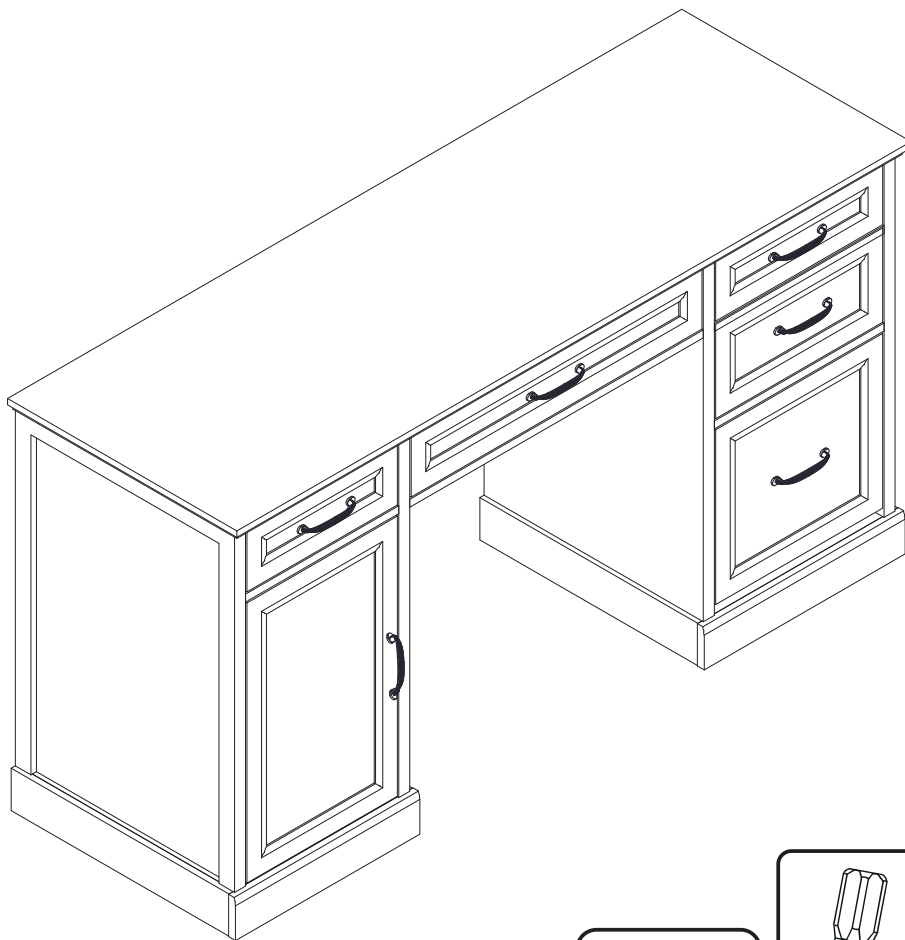

Tools Recommended

THIS INSTRUCTIONS CONTAINS IMPORTANT SAFETY INFORMATION.
PLEASE READ BEFORE ASSEMBLY AND KEEP FOR FUTURE REFERENCE.

IMPORTANT NOTICE

- This product contains small components, please ensure that they are kept away from small children.
- THIS INSTRUCTIONS CONTAINS IMPORTANT SAFETY INFORMATION. PLEASE READ BEFORE ASSEMBLY AND KEEP FOR FUTURE REFERENCE.
- Read each step carefully. It is very important that each step of instruction is performed in the correct order. If these steps are not followed in sequence, assembly difficulties will occur.
- Make sure all parts are included. Most parts are labelled or stamped on the raw edge.
- Work in spacious area, preferably on a carpet, near the place the unit will be used.
- Do not use power tools to assemble your furniture. Power tools may strip or damage the parts.
- Move your new furniture carefully, with two people lift and carry the unit to it's new location.
- Never push, drag or pull your furniture (especially on carpet)





PLEASE DO NOT RETURN PRODUCT TO US IMMEDIATELY

If a part is missing or damaged, email our customer service. We will gladly ship your replacement parts FREE of charge.

Need Parts or Assistance?

For Prompt, reliable service, please have your assemble instruction ready

 WARNING	
	Children have died from furniture tipover. To reduce the risk of furniture tipover: <ul style="list-style-type: none">- ALWAYS install Anti-tip device provided.- NEVER put a TV on this product.- NEVER allow children to stand, climb or hang on any drawers, doors, or shelves.- NEVER open more than one drawer at a time.- Place heaviest items in the lowest drawers.
	<p><i>This is a permanent label. Do not remove!</i></p>

The installation direction should be aligned with the instructions to prevent plate breakage caused by product tipping during installation.

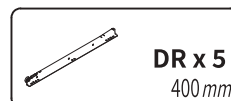
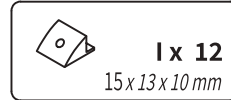
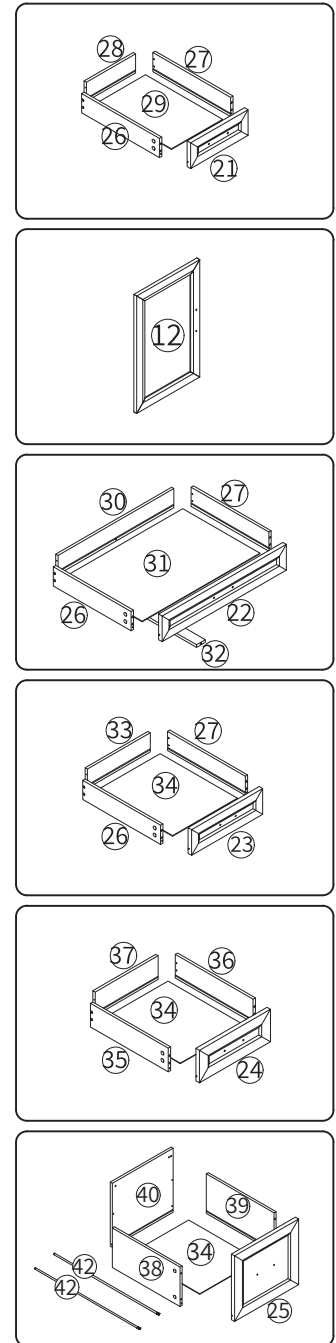
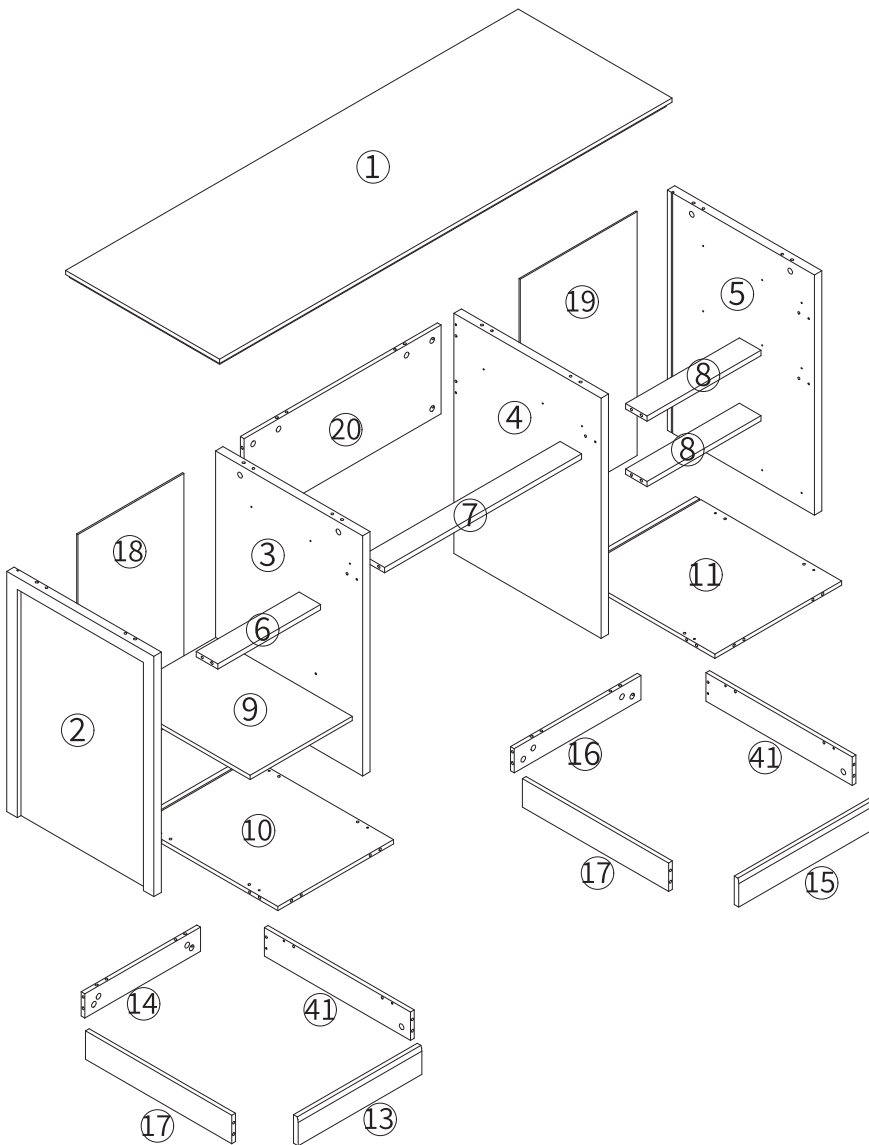

Step 1

Insert screws (A) into the part①,⑬,⑮. As shown in the figure.

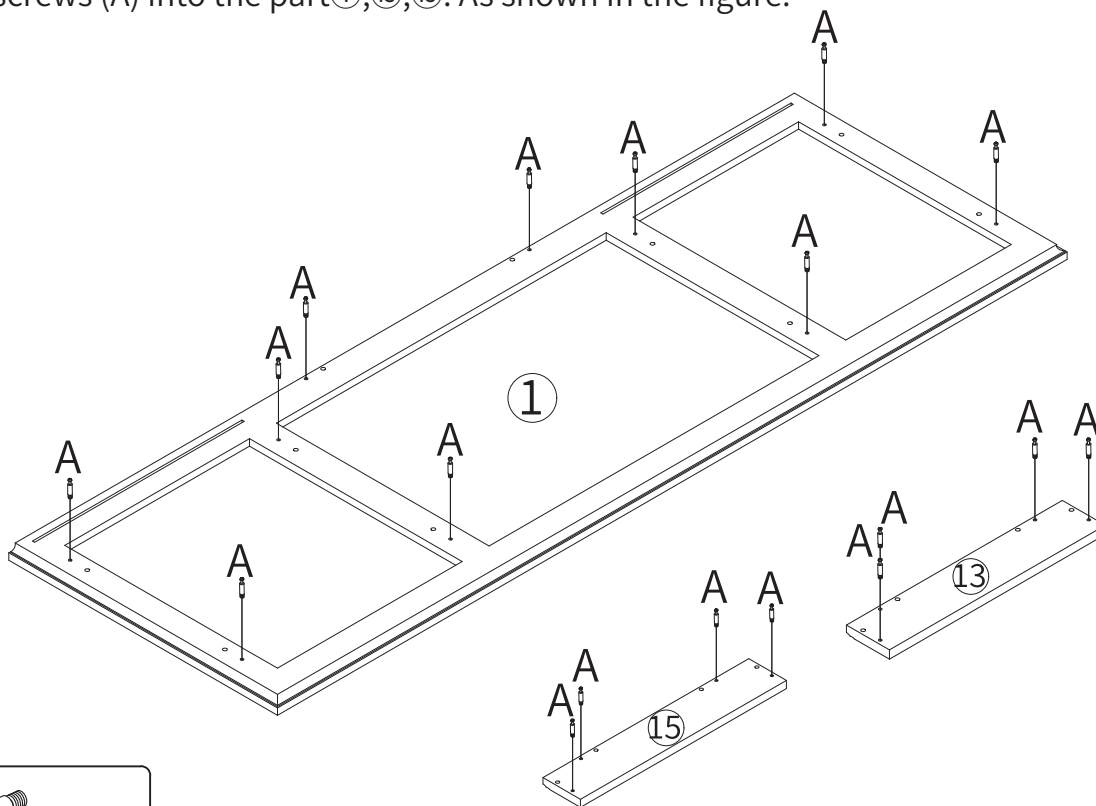

Step 2

Insert screws (A) into the part②,⑤.

Use screws (E) to fix the slide rail (CL) on part② and fix the slide rail (CR) on part⑤. As shown in the figure.

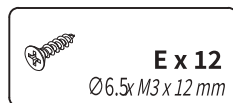
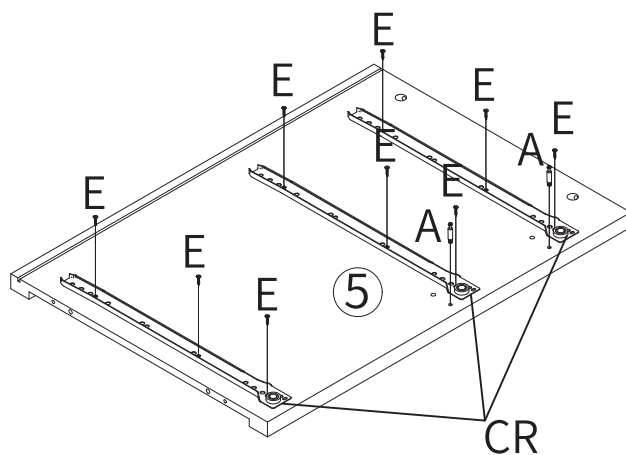
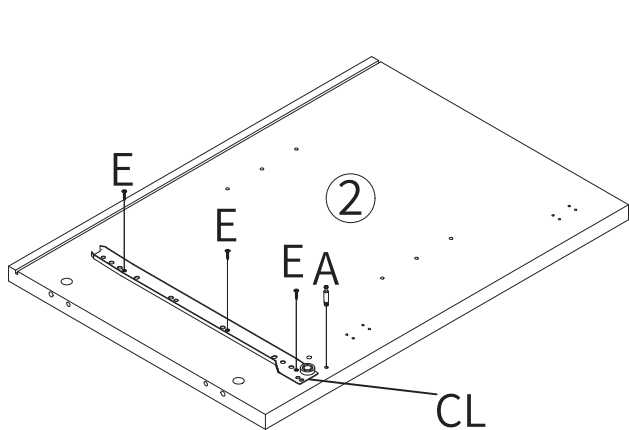
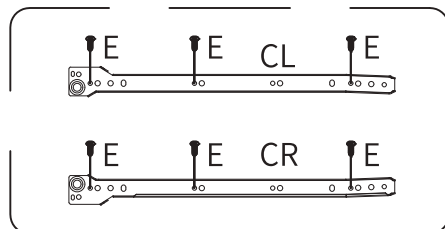

Step 3

Insert screws (A) into the part③.

Lock the guide rail (CR) to the left side of the part③ with the screw (E). Then turn it 180 degrees and lock the guide rail (CL) to the right side of the part③ with the screw (E). As shown in the figure.

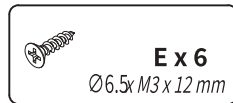
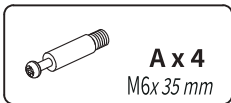
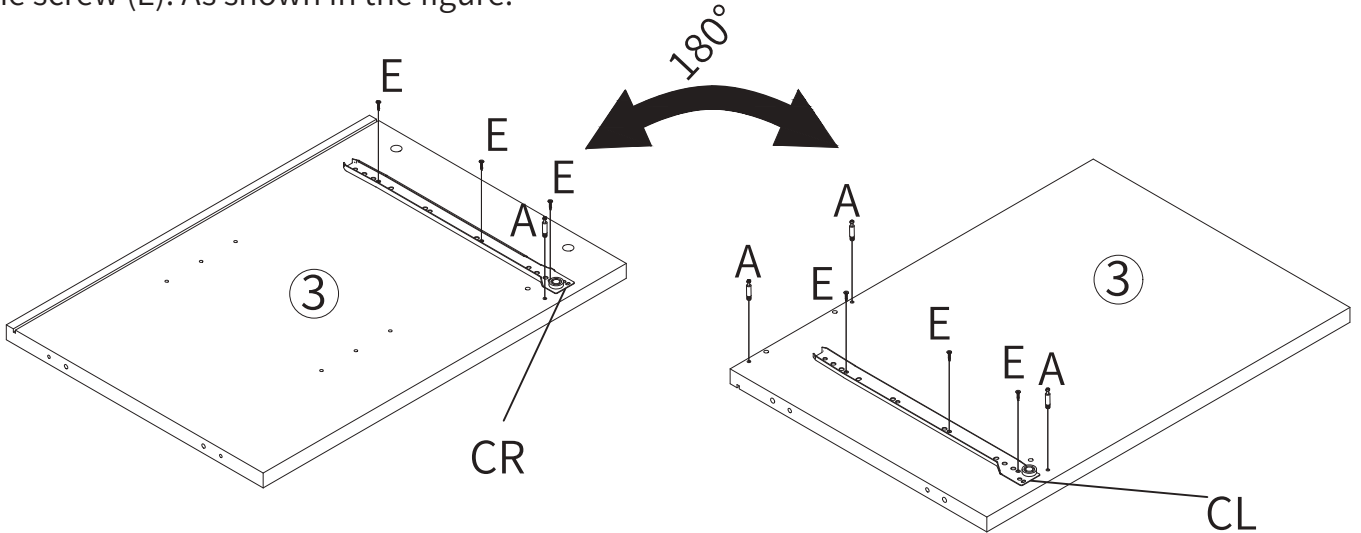
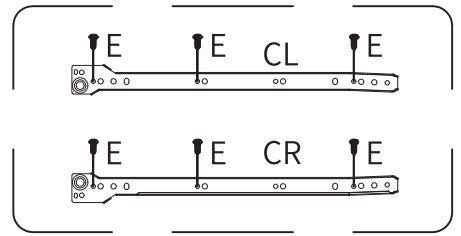

Step 4

Insert screws (A) into the part④.

Lock the guide rail (CL) to the right side of the part④ with the screw (E). Then turn it 180 degrees and lock the guide rail (CR) to the left side of the part④ with the screw (E). As shown in the figure.

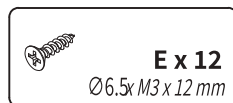
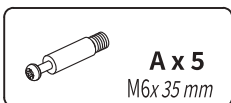
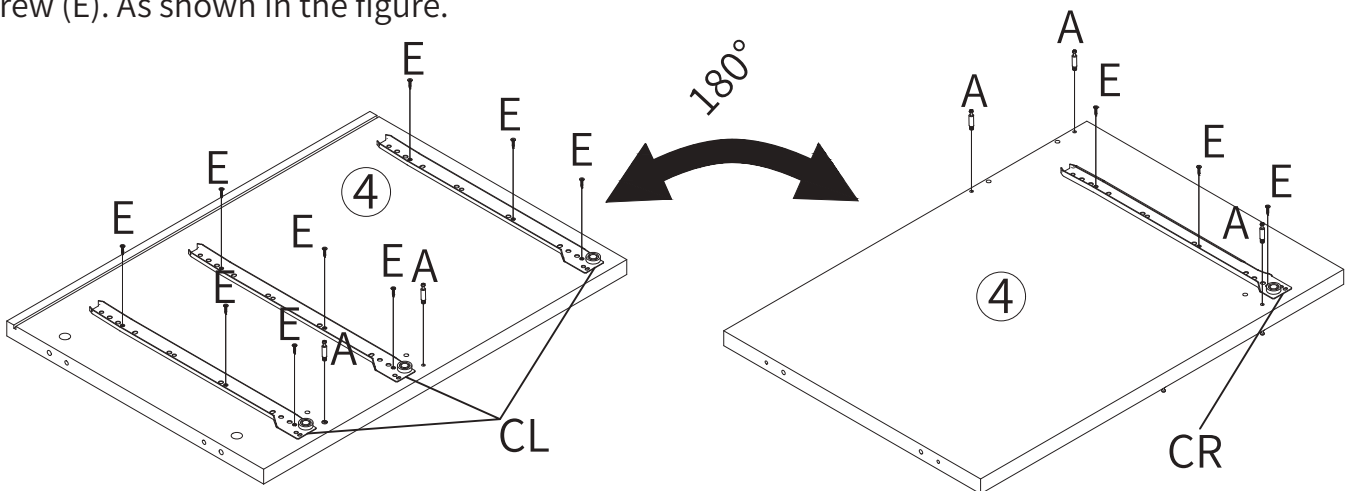
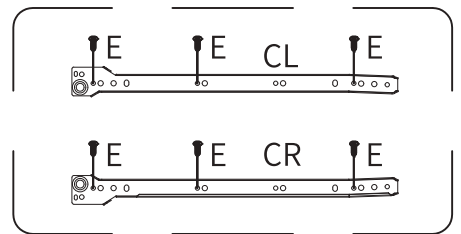

Step 5

Insert screws (A) into the part⑩,⑰,④①. As shown in the figure.

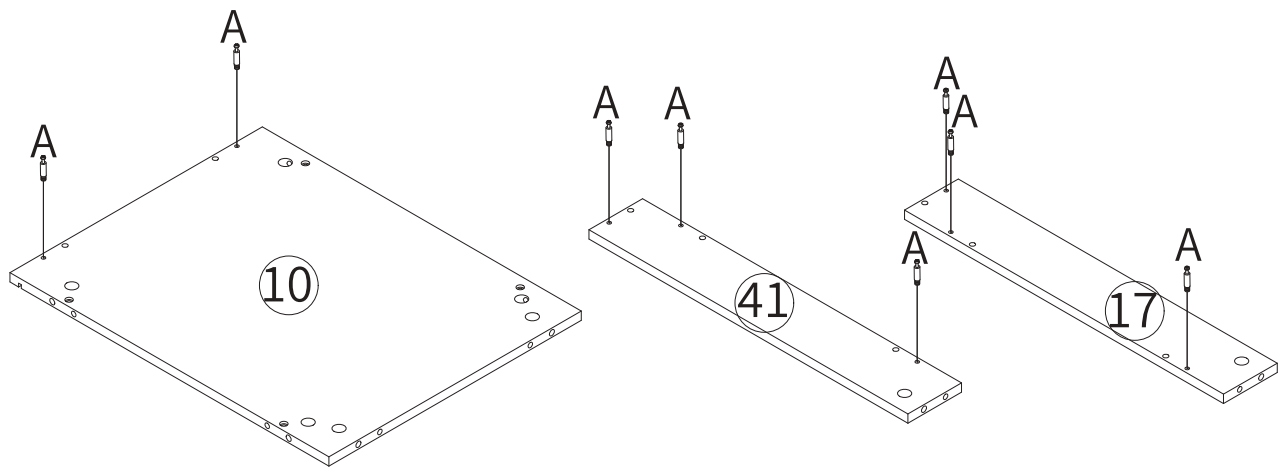

Step 6

Insert the dowel (C) on part⑩, then connect part⑩ and part⑭ with eccentric (B), put the cam lock (B) into the corresponding holes on part⑭ and use a screwdriver to turn it clockwise to tighten. As shown in the figure.

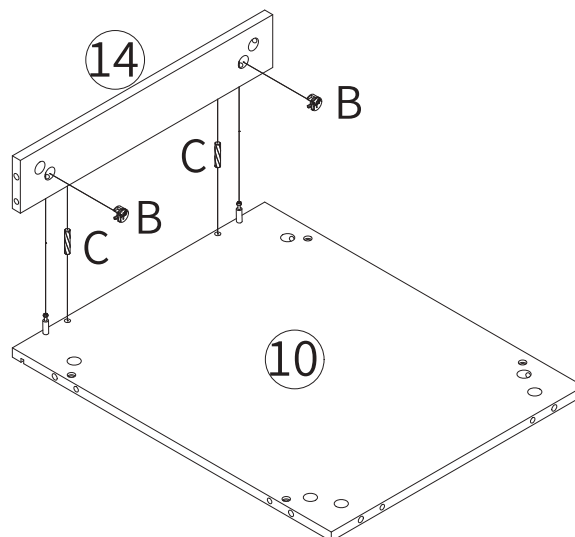
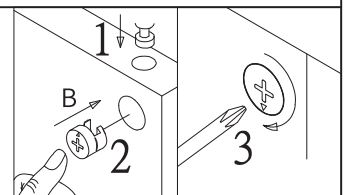

Step 7

Insert the dowel (C) on part 10, 14.
Attach part 17, 41 to assembled unit with eccentric (B).
Turn it clockwise to tighten. As shown in the figure.

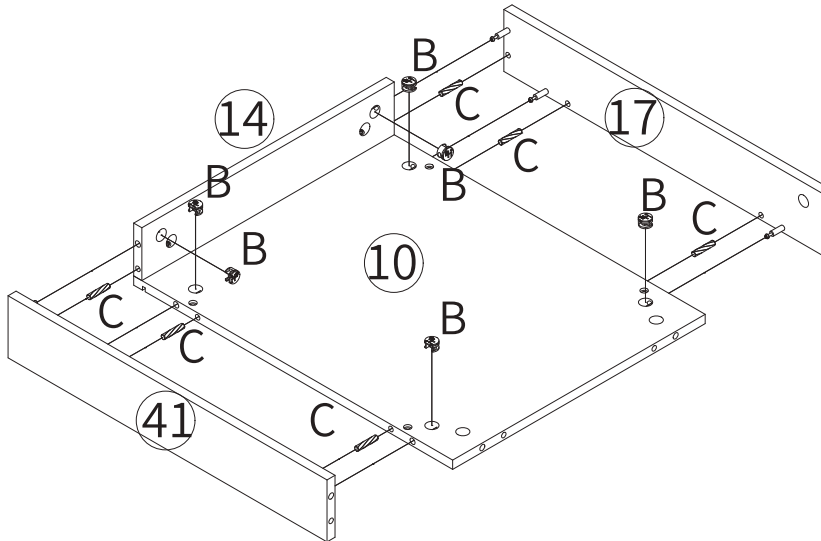
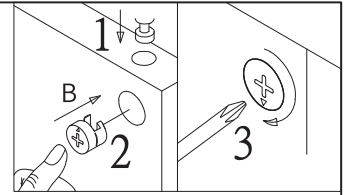

Step 8

Insert the dowel (C) on part 13.
Attach part 13 to assembled unit with eccentric (B).
Turn it clockwise to tighten. As shown in the figure.

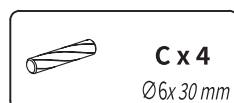
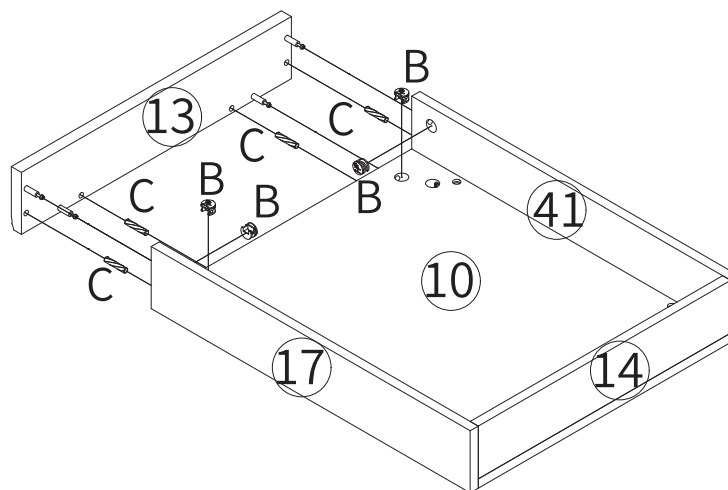
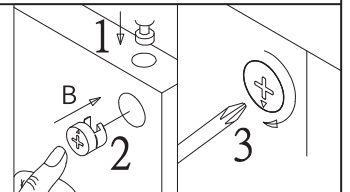

Step 9

Insert the dowel (C) on part②,
then connect part② and part⑥ with eccentric (B).
Turn it clockwise to tighten. As shown in the figure.

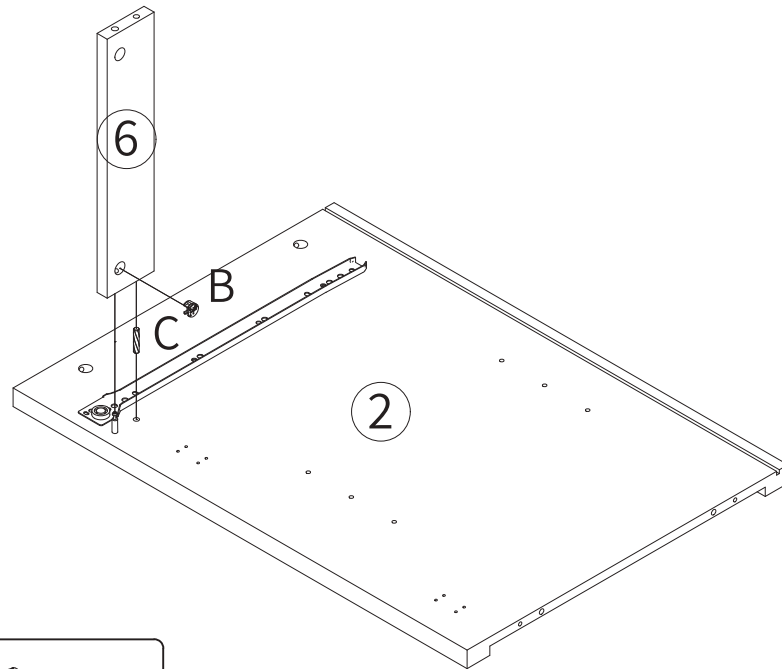
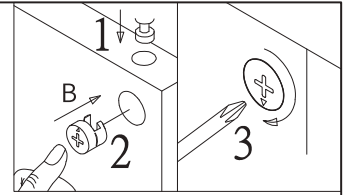

Step 10

Insert the dowel (C) on part③,
then connect part③ and part⑥ with eccentric (B).
Turn it clockwise to tighten. As shown in the figure.

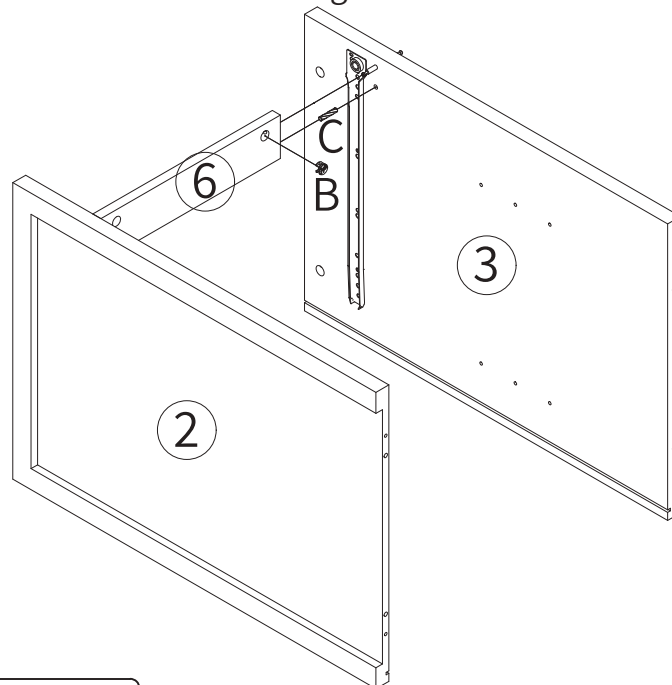
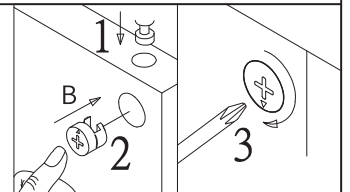

Step 11

Insert the dowel (C) on part②,③.

Assemble part②,③ and part⑩ with screw (D). As shown in the figure.

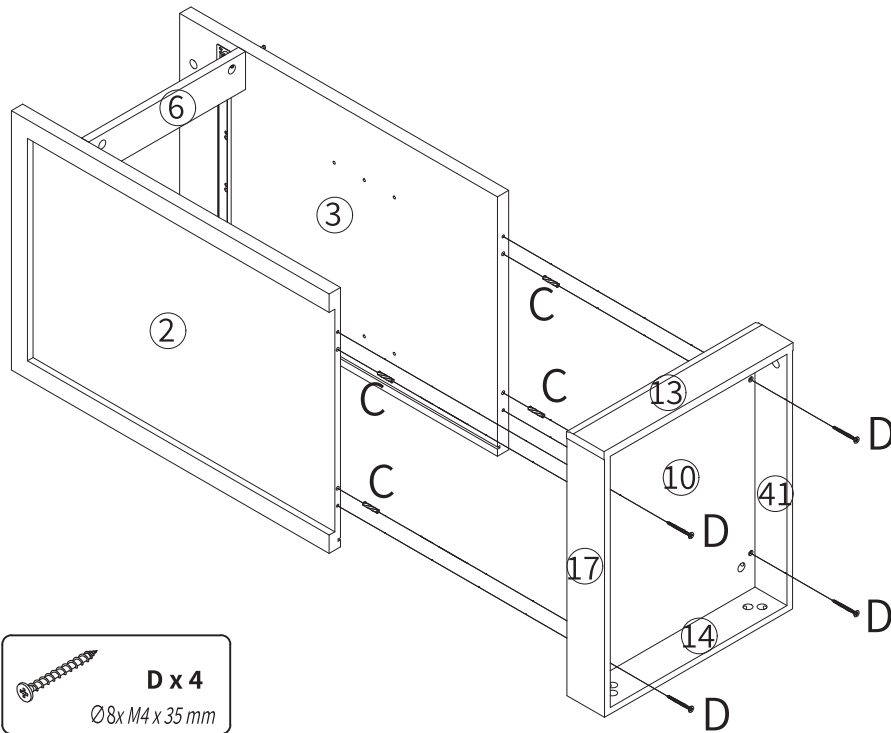

Step 12

Insert screws (A) into the part⑪,⑰,④①. As shown in the figure.

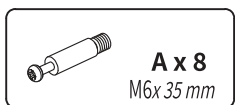
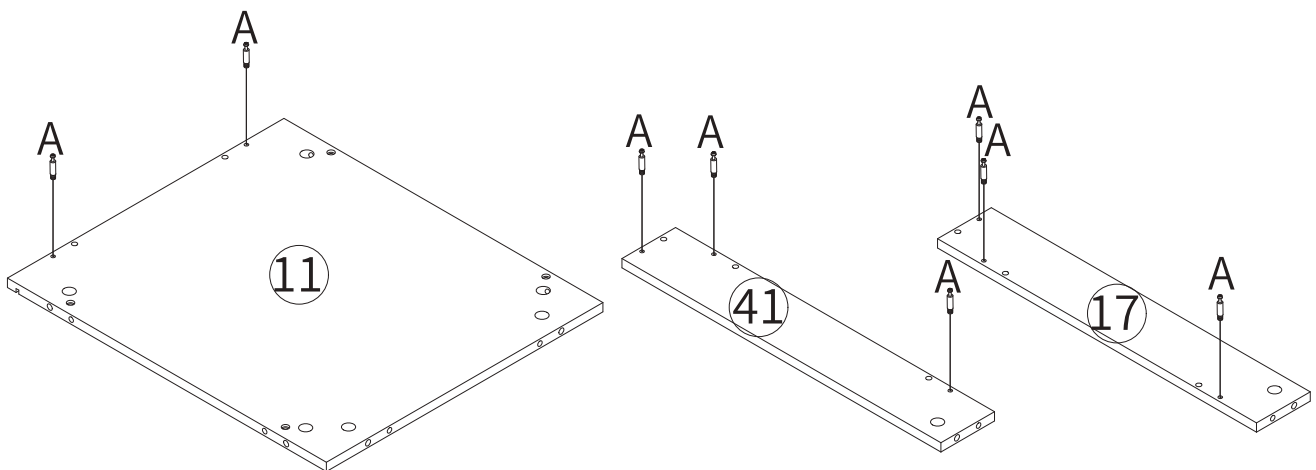

Step 13

Insert the dowel (C) on part①①, then connect part①① and part①⑥ with eccentric (B). Turn it clockwise to tighten. As shown in the figure.

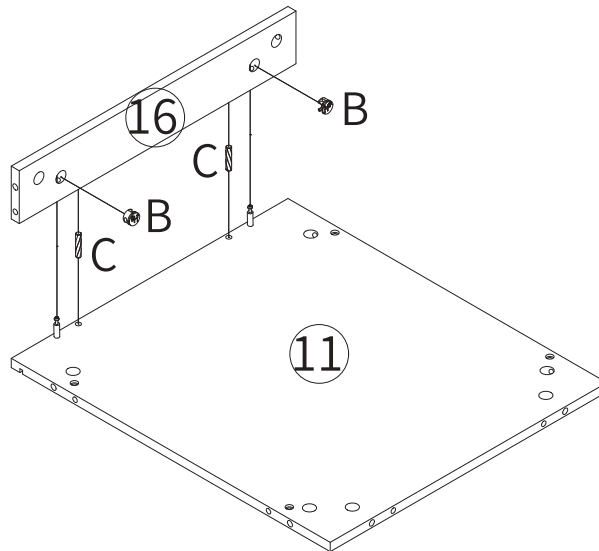
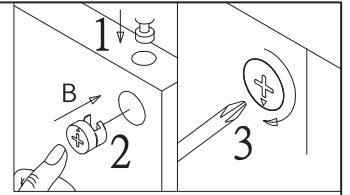

Step 14

Insert the dowel (C) on part①①,①⑥. Attach part①⑦,④① to assembled unit with eccentric (B). Turn it clockwise to tighten. As shown in the figure.

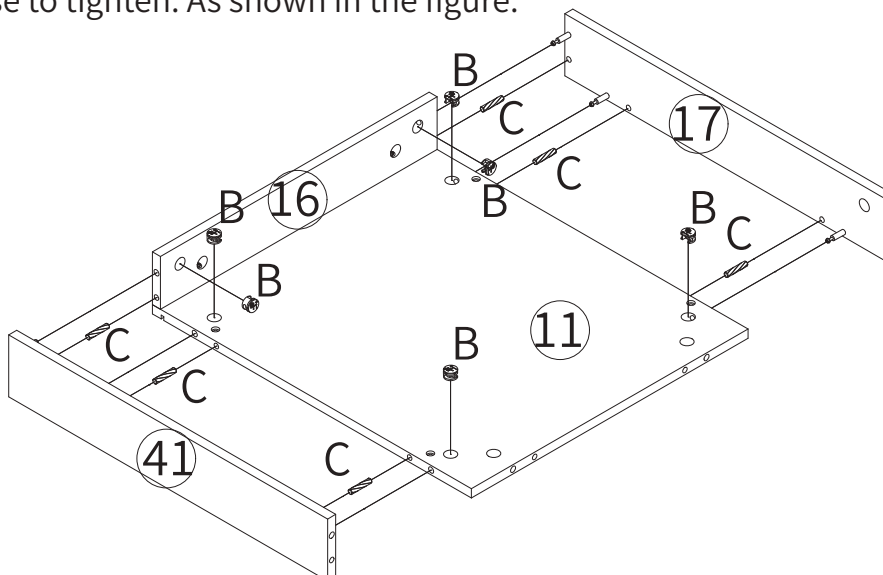
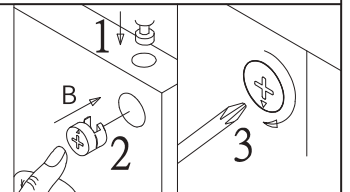

Step 15

Insert the dowel (C) on part 15.
Attach part 15 to assembled unit with eccentric (B).
Turn it clockwise to tighten. As shown in the figure.

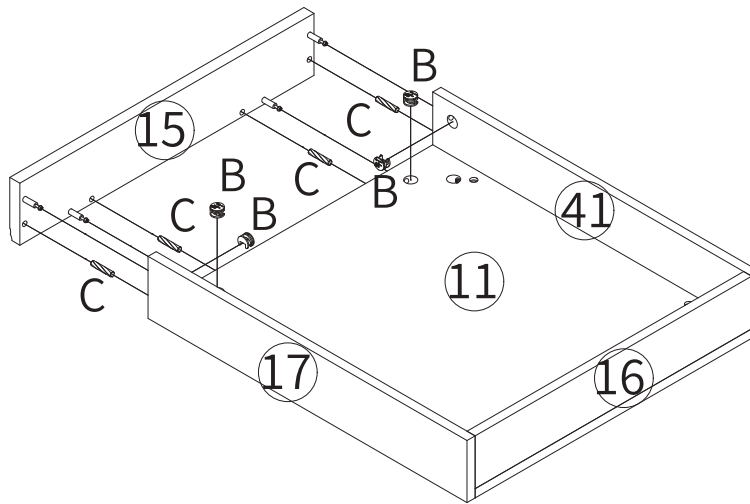
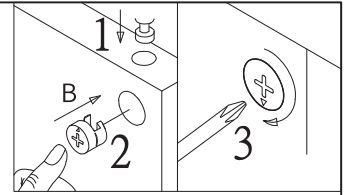

Step 16

Insert the dowel (C) on part 5,
then connect part 5 and part 8 with eccentric (B).
Turn it clockwise to tighten. As shown in the figure.

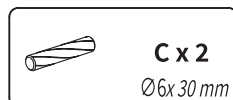
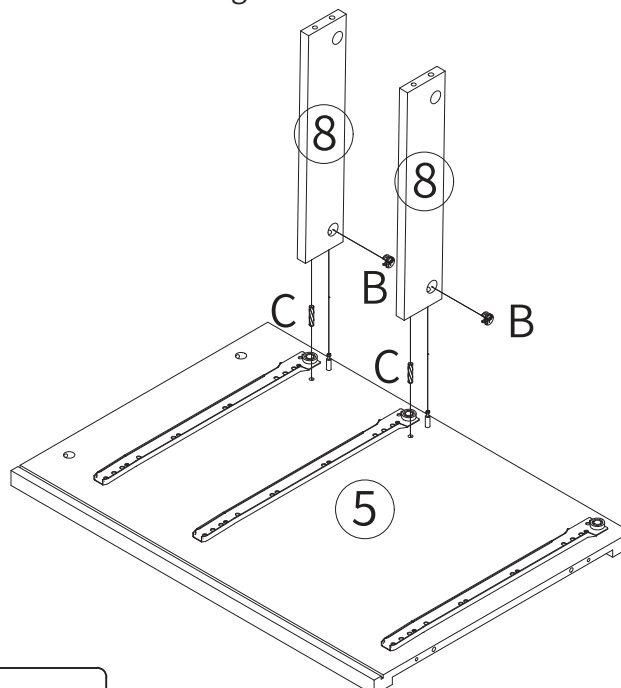
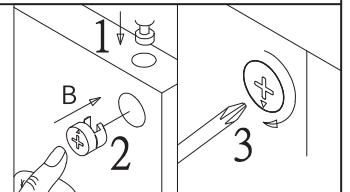

Step 17

Insert the dowel (C) on part④,
then connect part④ and part⑧ with eccentric (B).
Turn it clockwise to tighten. As shown in the figure.

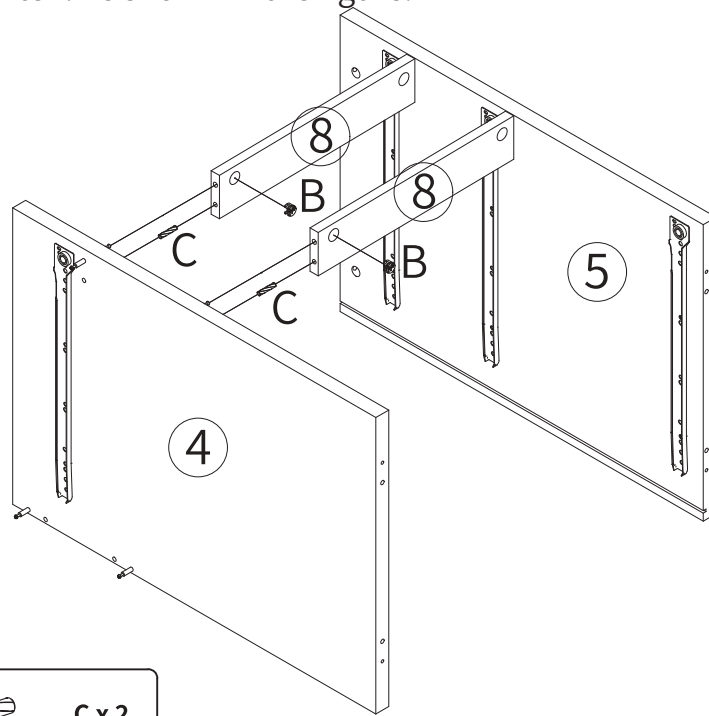
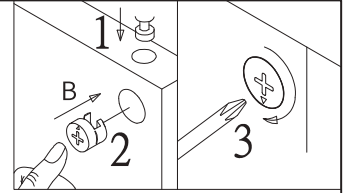

Step 18

Insert the dowel (C) on part④,⑤.
Assemble part④,⑤ and part⑪ with screw (D).
As shown in the figure.

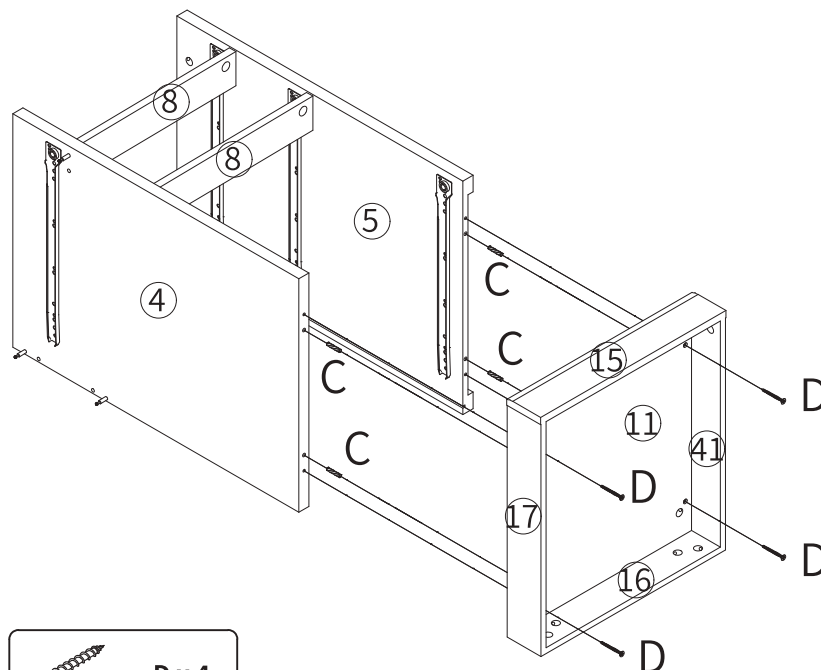

Step 19

Insert part ⑱, ⑲ along the slot first.
Then insert the dowel (C) on part ③, ④.
connect part ⑦, ⑳ and part ③, ④ with eccentric (B).
Turn it clockwise to tighten. As shown in the figure.

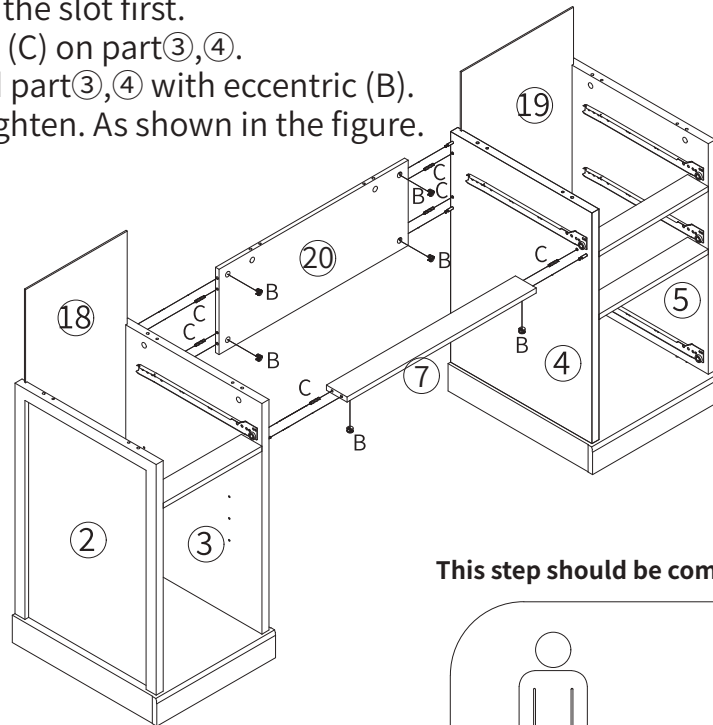
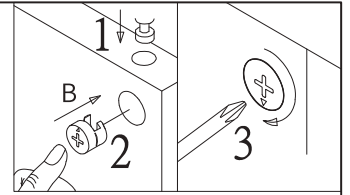

This step should be completed by two people together

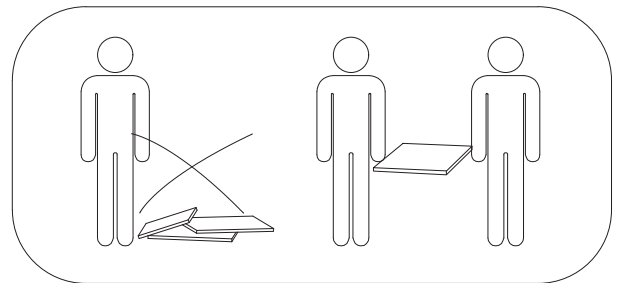

Step 20

Insert the dowel (C) on corresponding holes.
Attach part ① to assembled unit with eccentric (B).
Turn it clockwise to tighten. As shown in the figure.

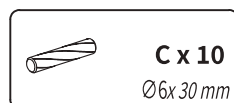
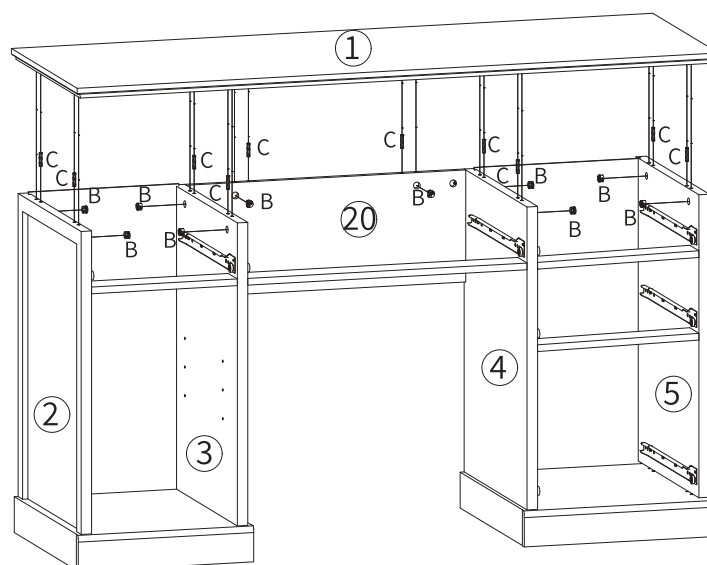
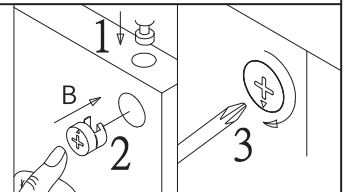

Step 21

Use screws (J) to lock the back panel buckle (I) to make the product more stable. As shown in the figure.

Install anti-tipping devices (H) as shown.

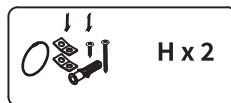
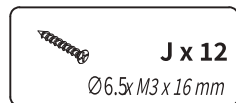
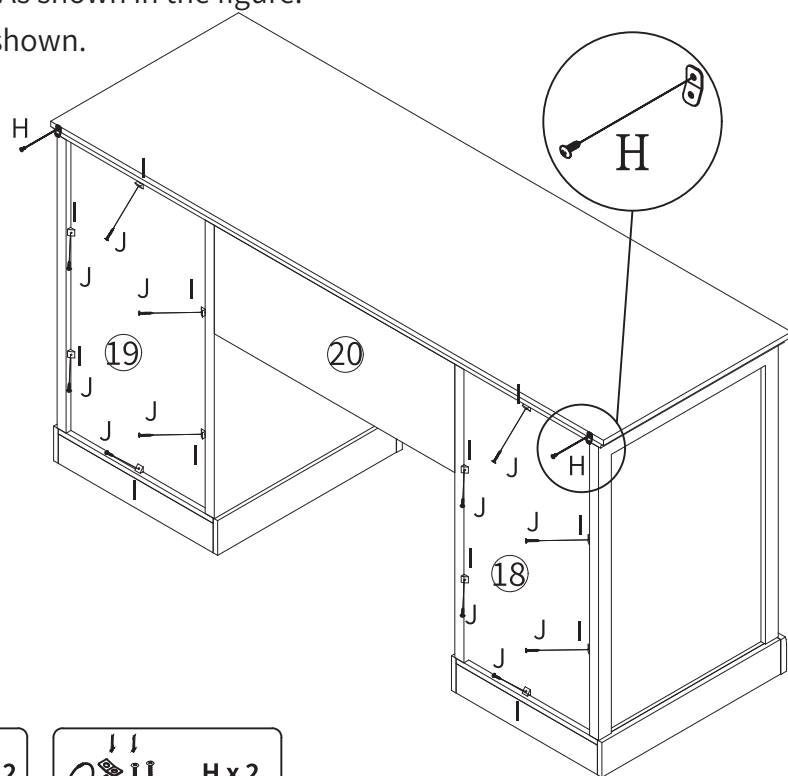

Step 22

Use the screw (D) to assemble the side panels (26, 27) and the back panel (28).

Insert the bottom panel (29) according to the slot.

Install the screw (A) on the drawer panel (21) as shown.

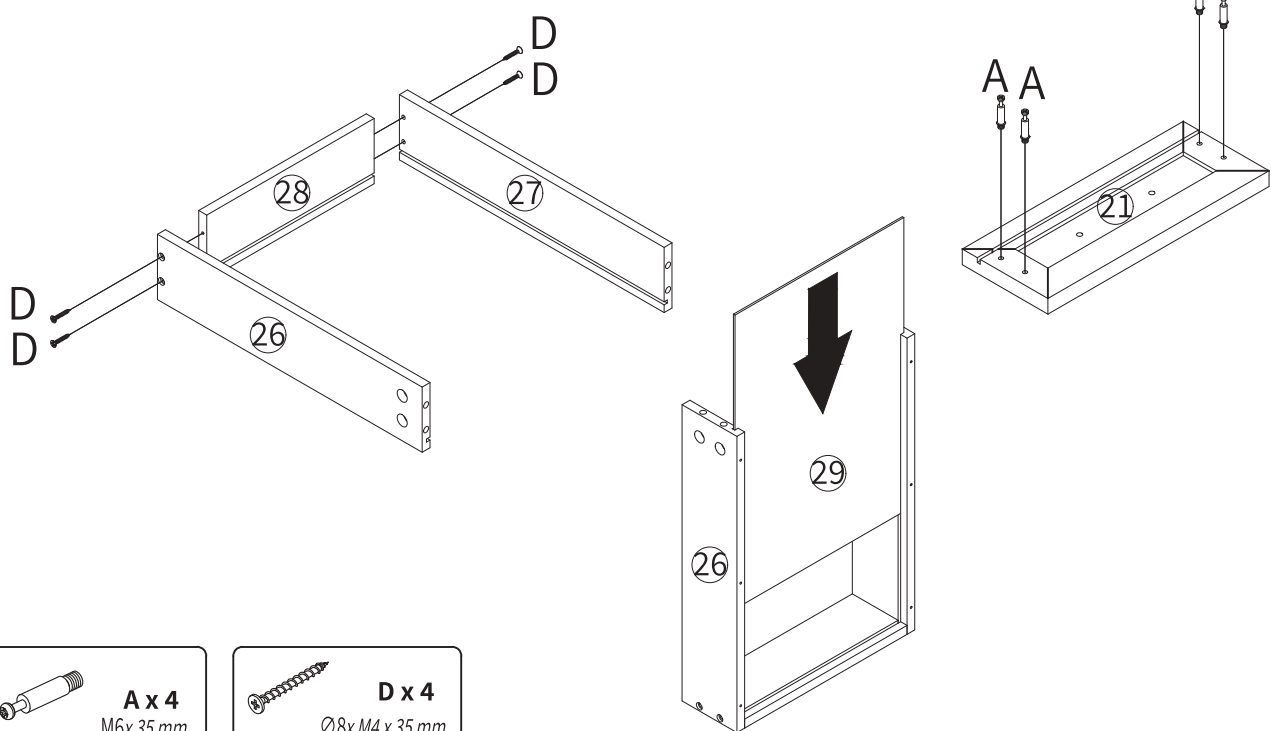

Step 23

Assemble the drawer panel (21) and the drawer side panels (26, 27). Turn it clockwise to tighten. Use screws (E) to install the guide rail (DL), (DR) on the side panel (26, 27). As shown in the figure.

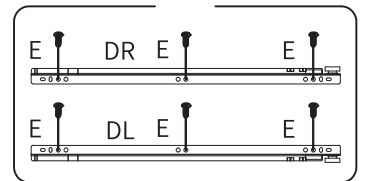
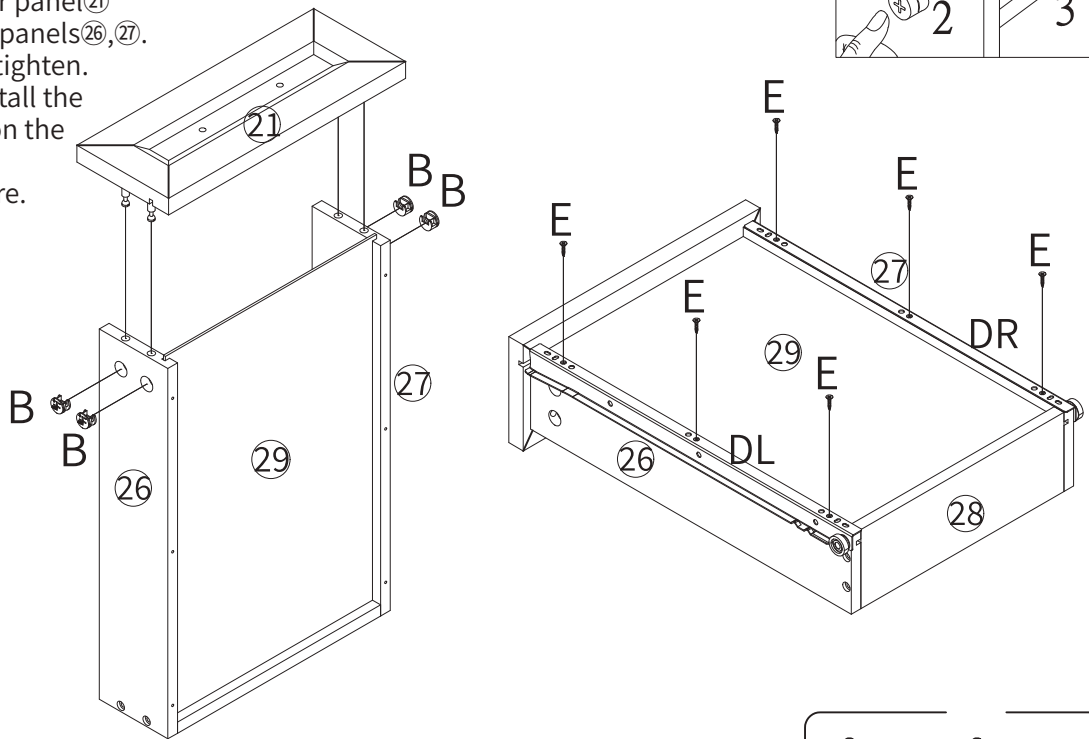

Step 24

Use the screw (G) to lock the handle (F) on the drawer panel (21). As shown in the figure.

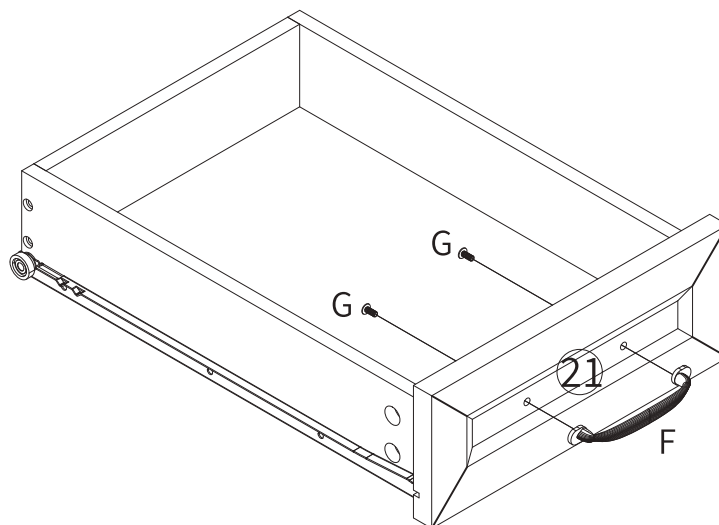

Step 25

Use the screw (D) to assemble the side panels (26, 27, 32) and the back panel (30).
 Insert the bottom panel (31) according to the slot.
 Install the screw (A) on the drawer panel (22) as shown.

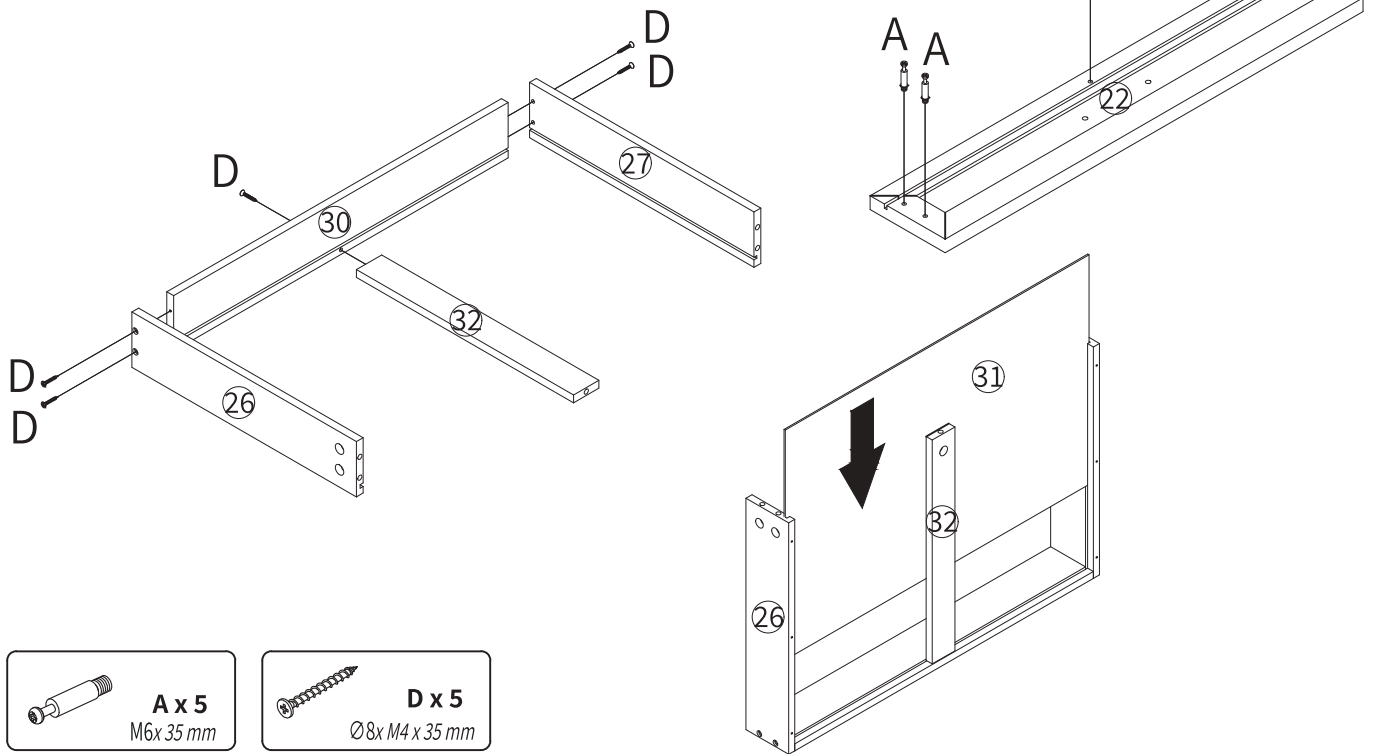

Step 26

Assemble the drawer panel (22) and the drawer side panels (26, 27, 32).
 Turn it clockwise to tighten.

Use screws (E) to install the guide rail (DL), (DR) on the side panel (26, 27). As shown in the figure.

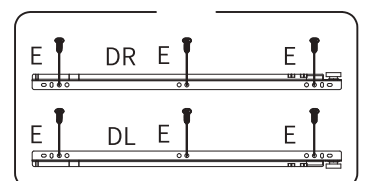
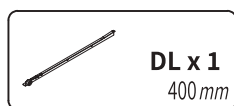
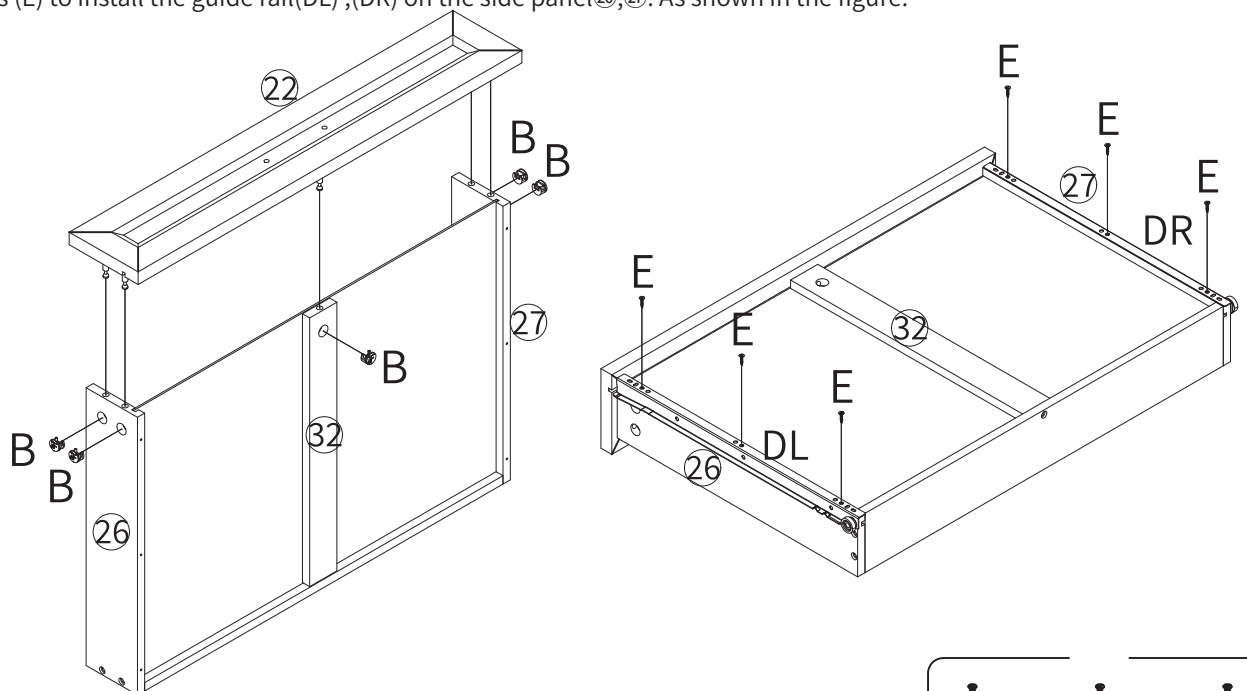
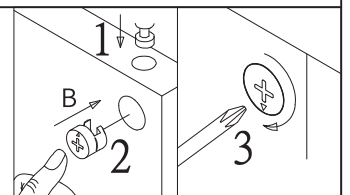

Step 27

Use the screw (G) to lock the handle (F) on the drawer panel (22). As shown in the figure.

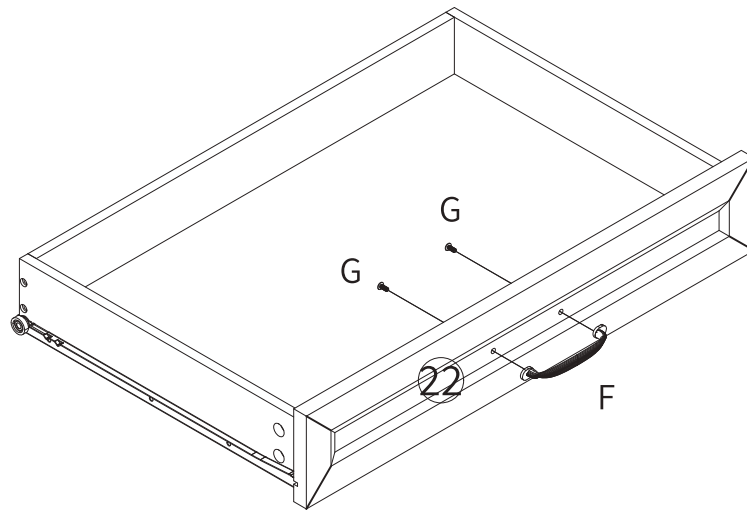

Step 28

Use the screw (D) to assemble the side panels (26, 27) and the back panel (33).
Insert the bottom panel (34) according to the slot.
Install the screw (A) on the drawer panel (23) as shown.

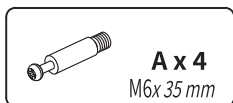
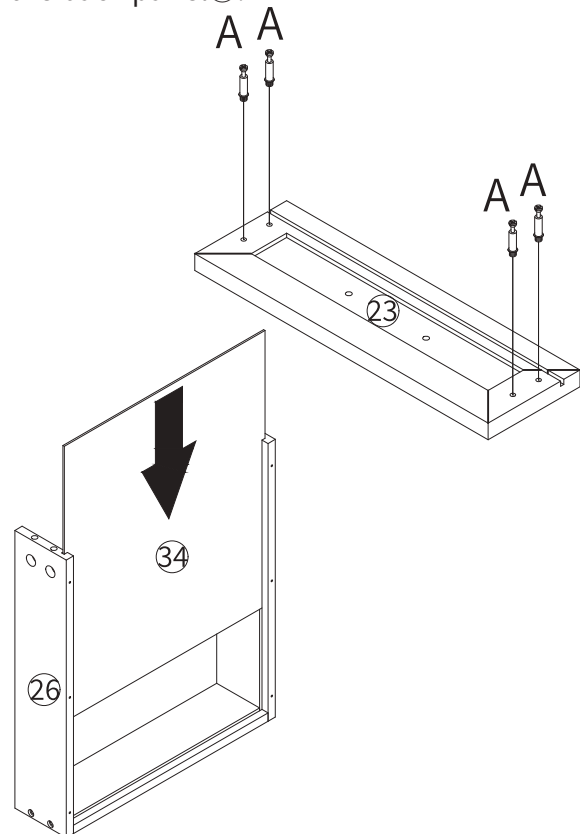
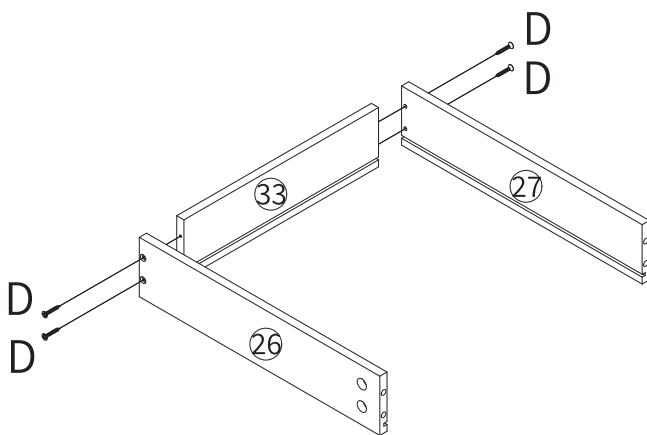

Step 29

Assemble the drawer panel⁽²³⁾ and the drawer side panels^(26, 27). Turn it clockwise to tighten. Use screws (E) to install the guide rail (DL) (DR) on the side panel^(26, 27). As shown in the figure.

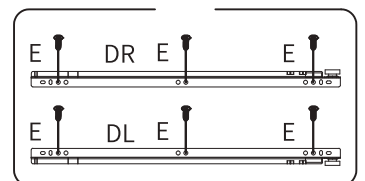
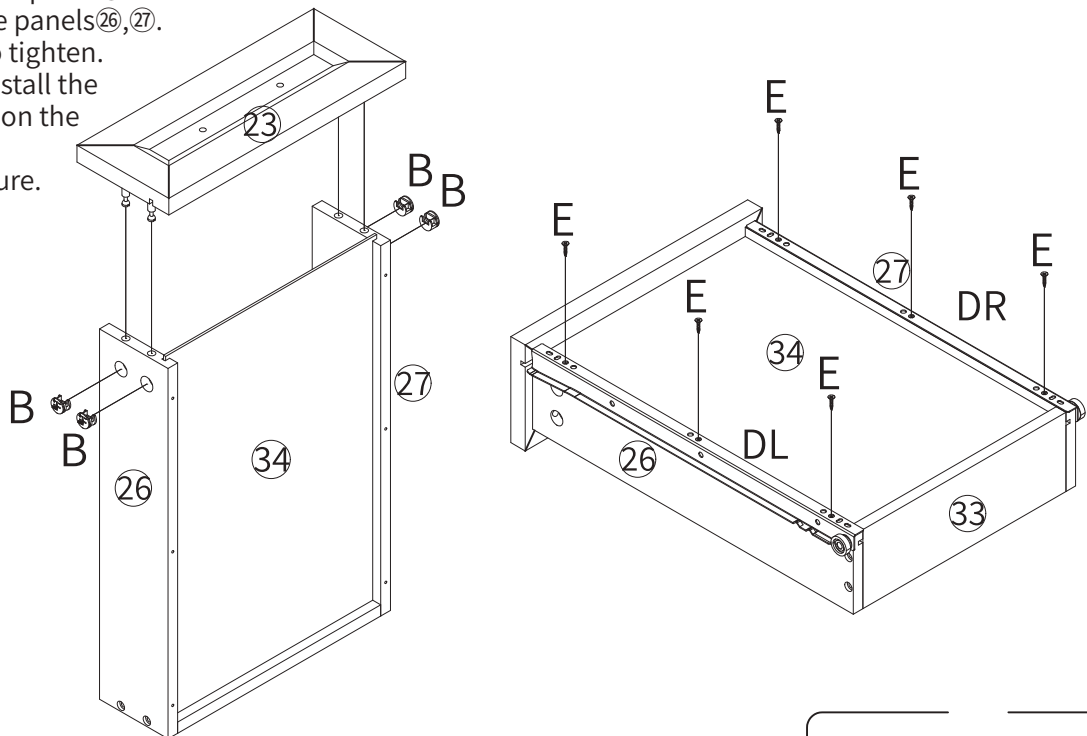

Step 30

Use the screw (G) to lock the handle (F) on the drawer panel⁽²³⁾. As shown in the figure.

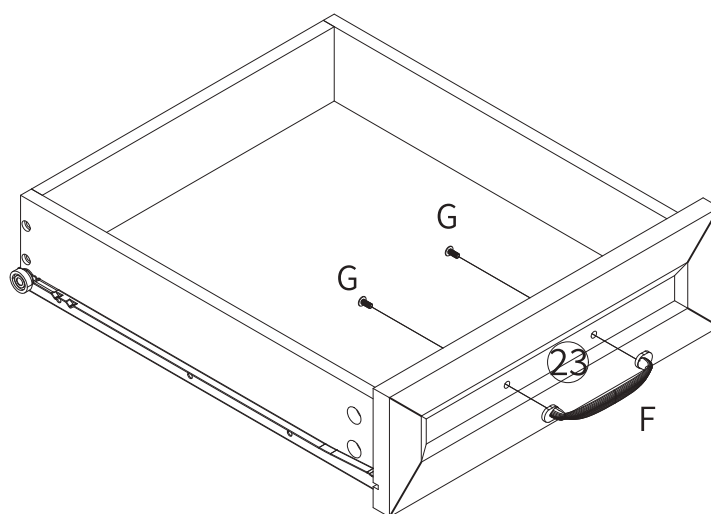

Step 31

Use the screw (D) to assemble the side panels³⁵,³⁶ and the back panel³⁷.
 Insert the bottom panel³⁴ according to the slot.
 Install the screw (A) on the drawer panel²⁴ as shown.

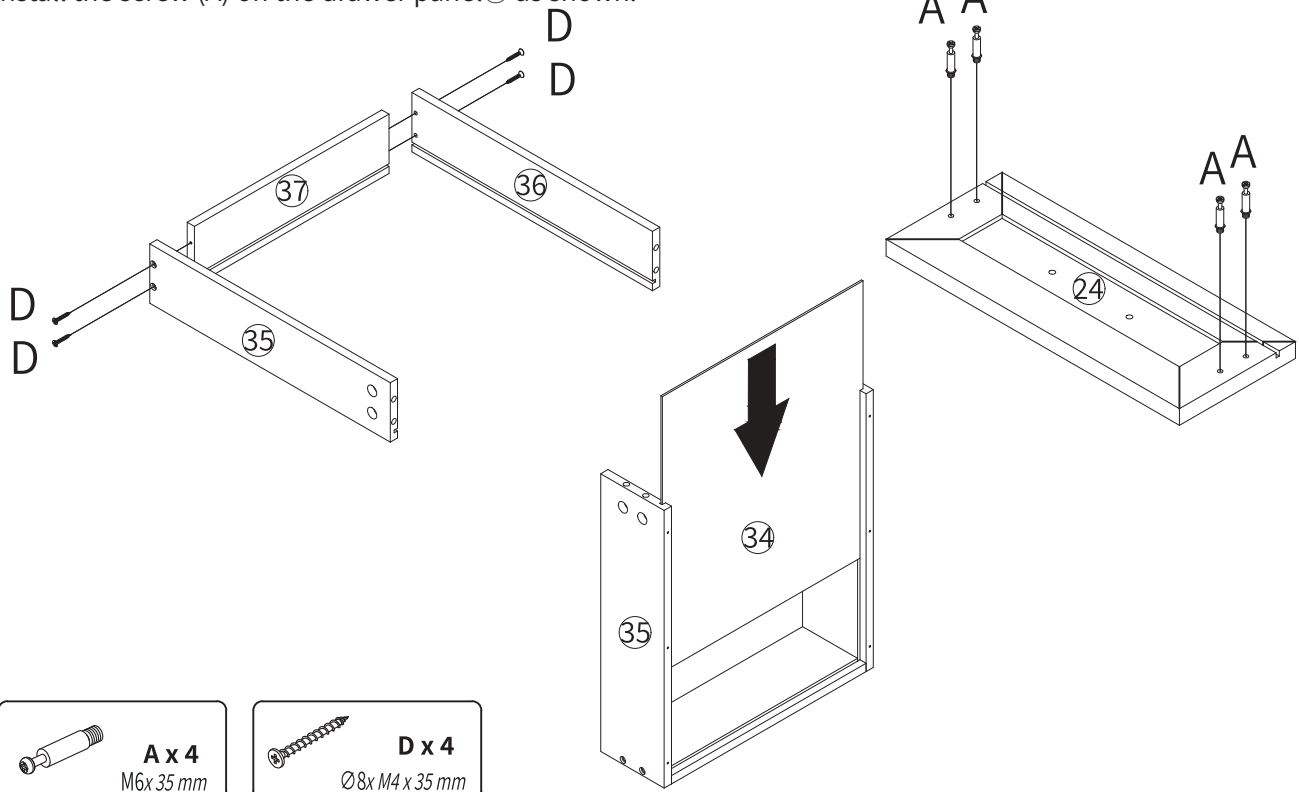

Step 32

Assemble the drawer panel²⁴ and the drawer side panels³⁵,³⁶.
 Turn it clockwise to tighten.
 Use screws (E) to install the guide rail (DL), (DR) on the side panel³⁵,³⁶.
 As shown in the figure.

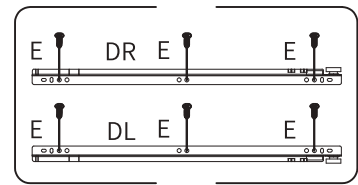
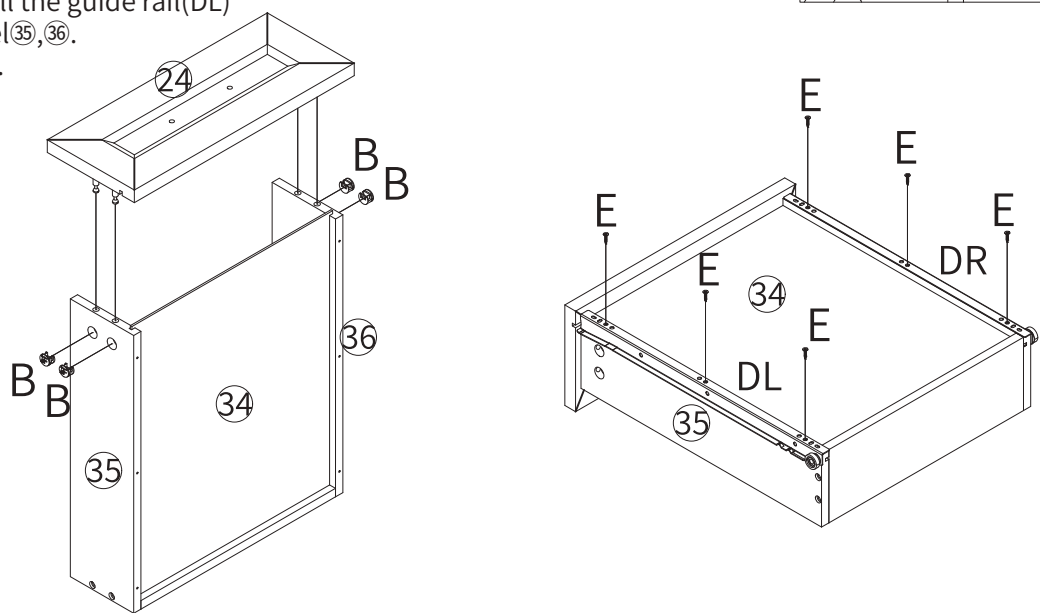

Step 33

Use the screw (G) to lock the handle (F) on the drawer panel⁽²⁴⁾. As shown in the figure.

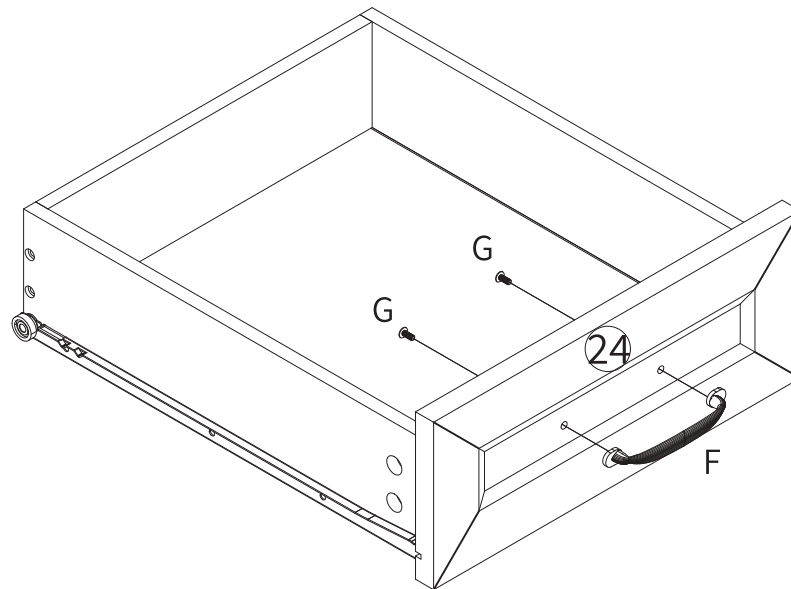

Step 34

Use the screw (D) to assemble the side panels^{(38), (39)} and the back panel⁽⁴⁰⁾. Insert the bottom panel⁽³⁴⁾ according to the slot. Install the screw (A) on the drawer panel⁽²⁵⁾ as shown.

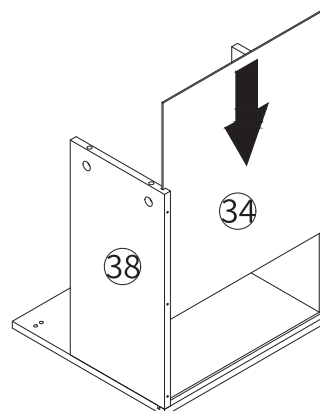
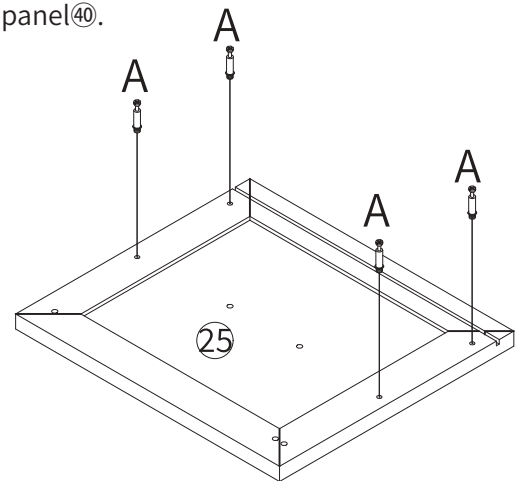
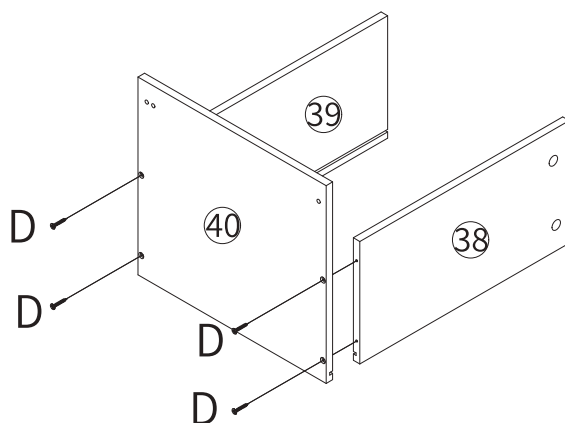

Step 35

Assemble the drawer panel⁽²⁵⁾ and the drawer side panels^{(38), (39)}.
Turn it clockwise to tighten.
Use screws (E) to install the guide rail (DL), (DR) on the side panel^{(38), (39)}.
As shown in the figure.

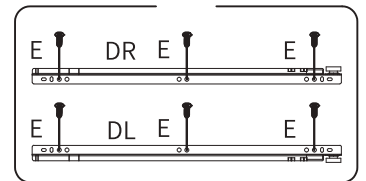
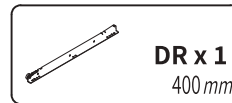
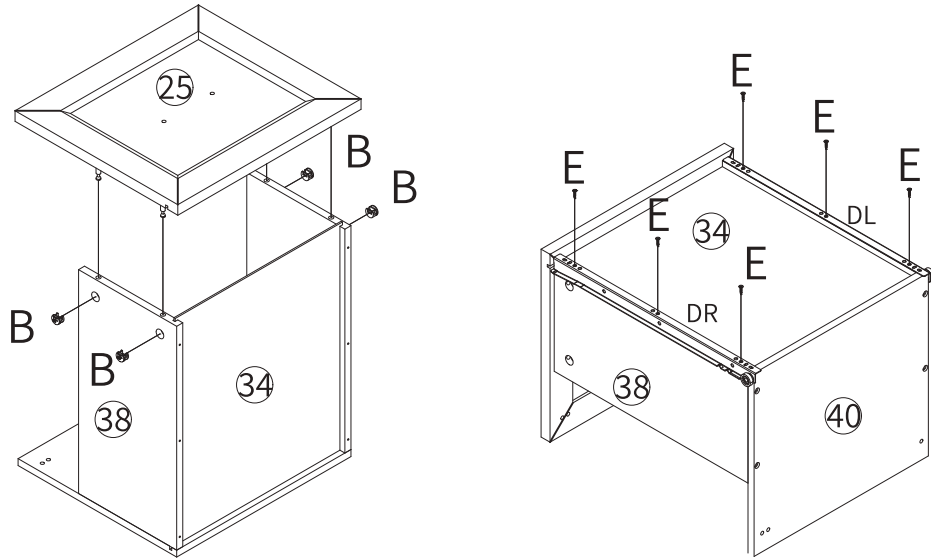
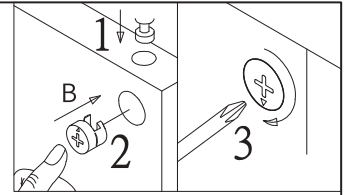

Step 36

Use the screw (G) to lock the handle (F) on the drawer panel⁽²⁵⁾. As shown in the figure.

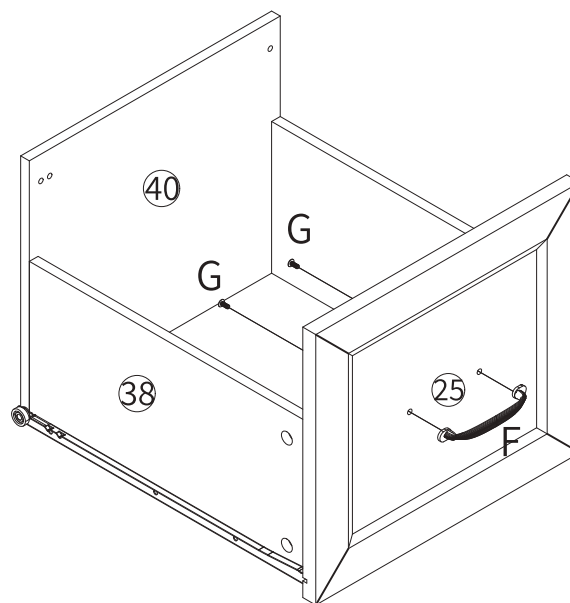

Step 37

Pass the part④② through the hole and install it into part②⑤. As shown in the figure.

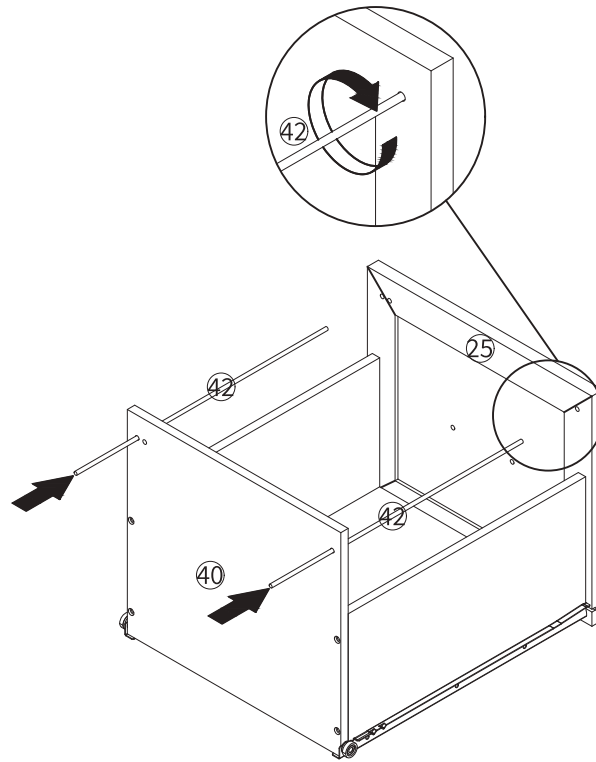

Step 38

Install the layer support(K) to part②③, as shown.
Then place part⑨ parallel on the left side of the cabinet.
As shown in the figure.

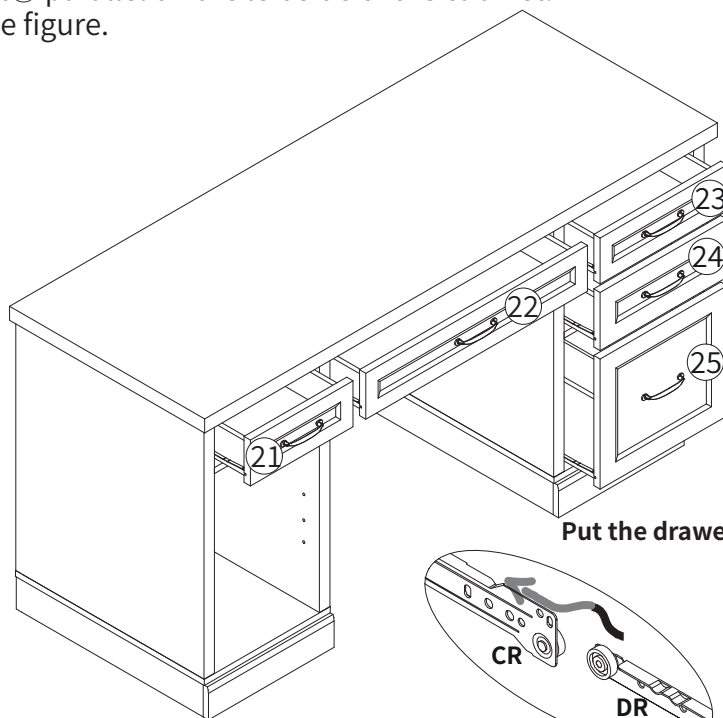

Put the drawer in the correct place as shown below.

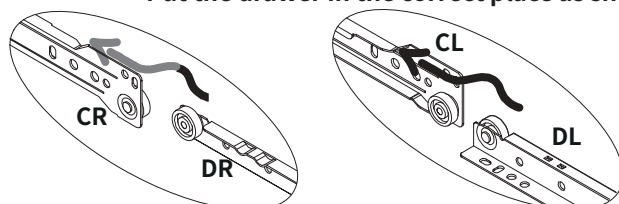

Step 39

Install the layer support (K) to part ②③, as shown.
Then place part ⑨ parallel on the left side of the cabinet.
As shown in the figure.

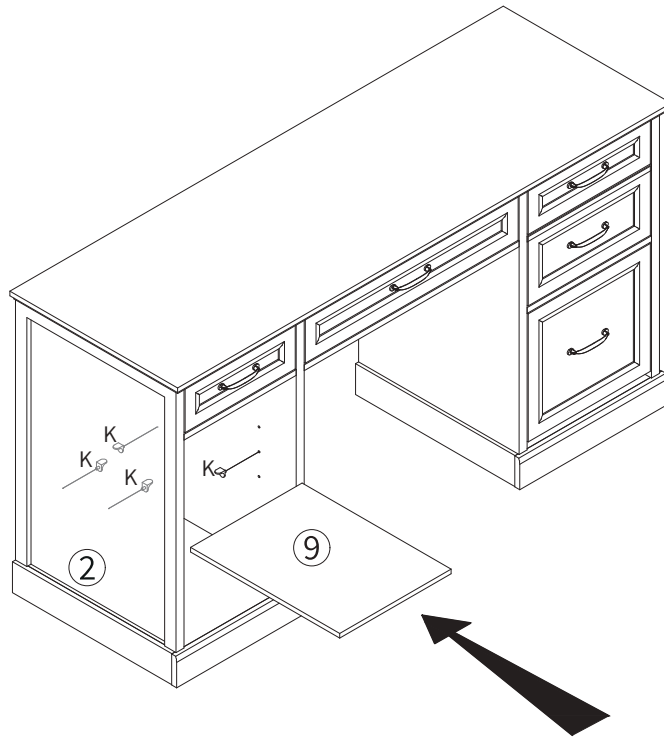

Step 40

First, use the screw (L) to lock the hinge (M) to part ⑫.
Then use the screw (N) to lock the handle (F)
on the drawer panel ⑫.
Use the screw (L) to lock the door panel to part ②.
Assemble the rubber feet in the part ③.
As shown in the figure.

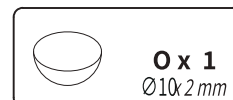
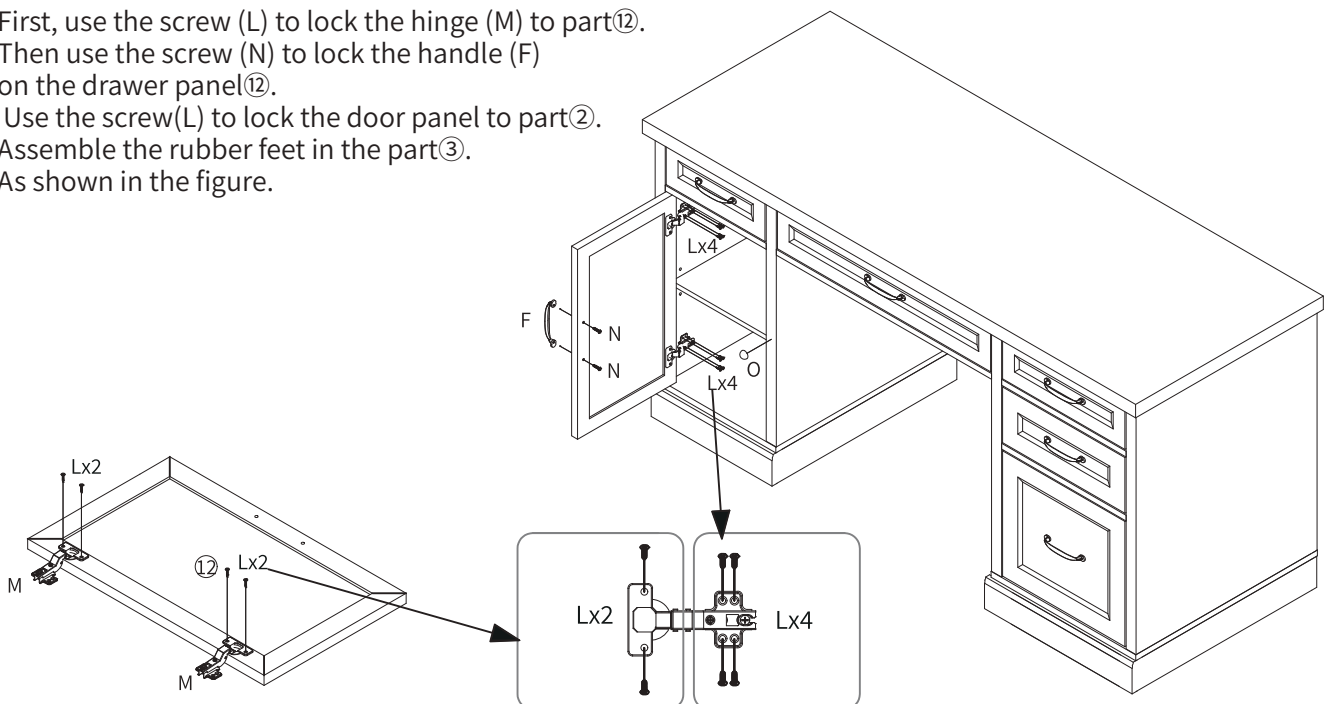

Step 41

As shown in the figure, adjust the screws on the hinge to position the door panel ⑫ to the most suitable position



Hinges Adjustment Tips

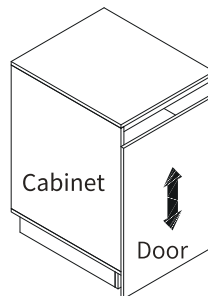
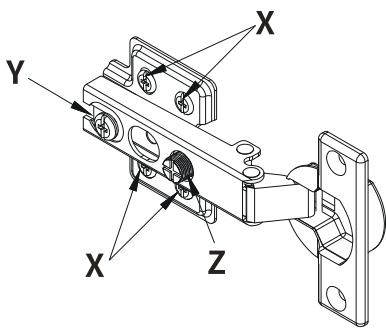

Loosening screw X can adjust the door panel vertically.

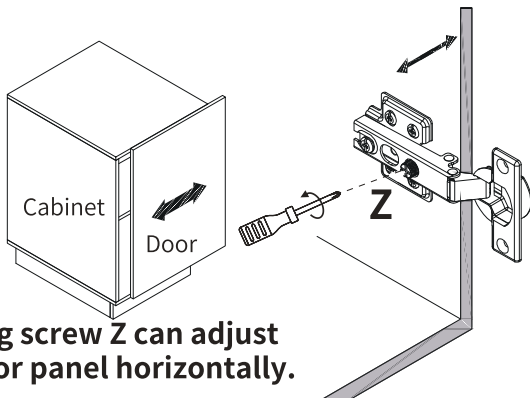
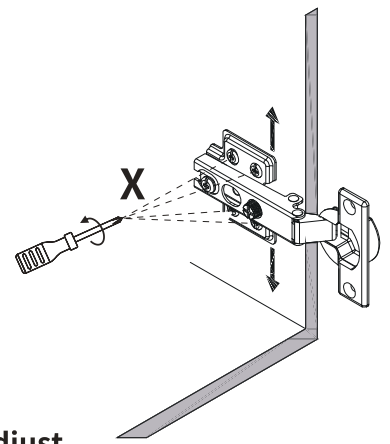

Loosening screw Z can adjust the door panel horizontally.

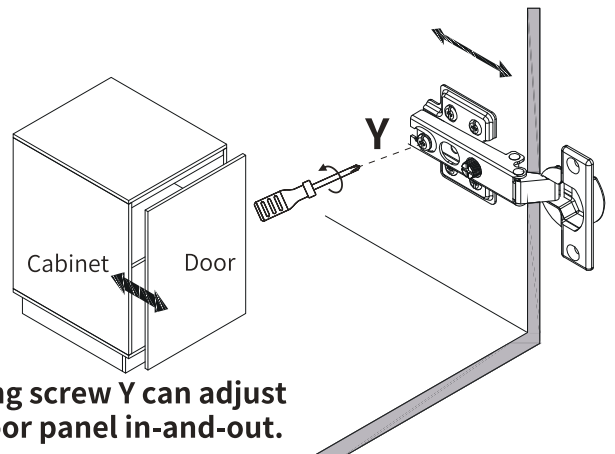

Loosening screw Y can adjust the door panel in-and-out.

Step 42

As shown in the figure, thread the steel wire in the anti fall device (H) into the illustrated part and tighten it

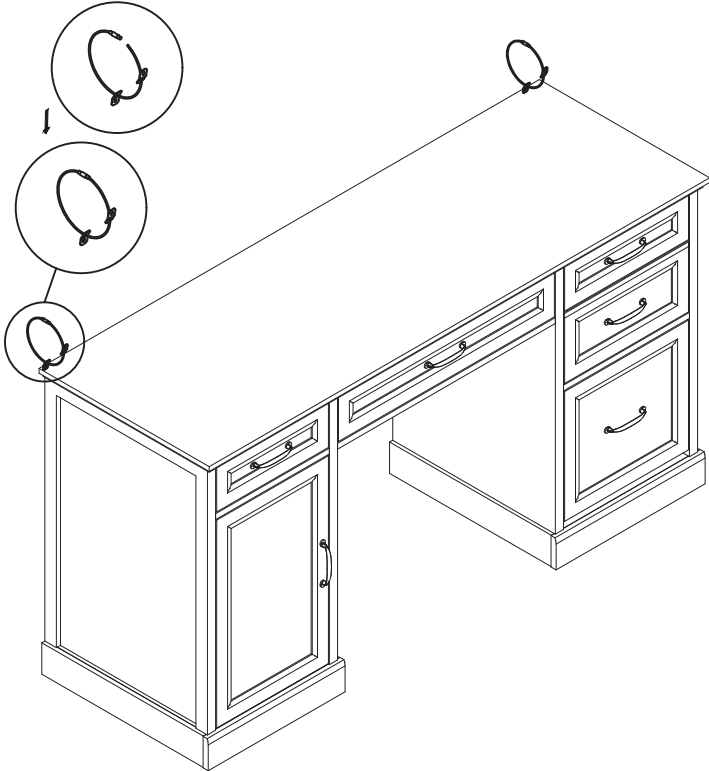

Step 42

WARNING: Always ensure the area to be drilled is free from hidden electrical wires, water and gas pipes.

