

STEP 3

Connect Round Leg (2) & Panel (C) to assembled unit, as shown:

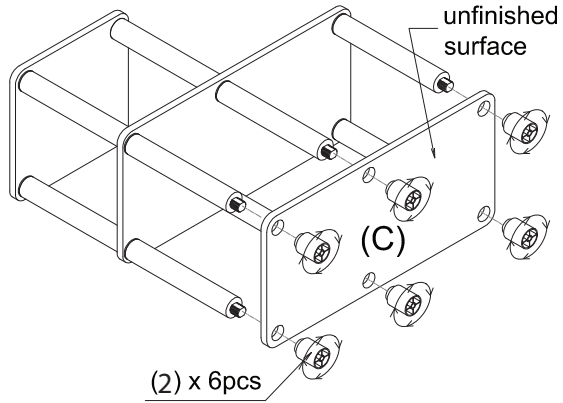

Recommended Maximum Weight

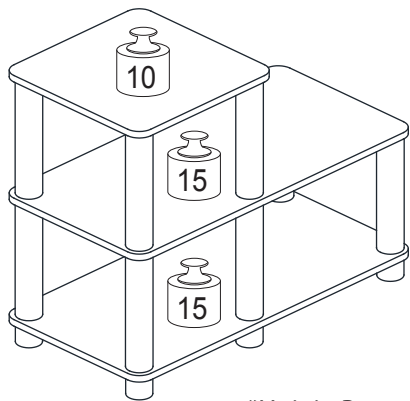

*Unit in Pound(lbs)

WARNING:

>This unit has been designed to support the maximum loads shown. Exceeding these load limits could cause sagging, instability, product collapse, and/or serious injury.

>DO NOT allow children to climb on unit.

>Put heavier items on lower shelves.

Assembly Instruction

00:10

Approx. 10 minutes





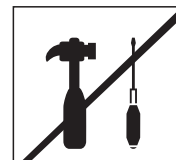

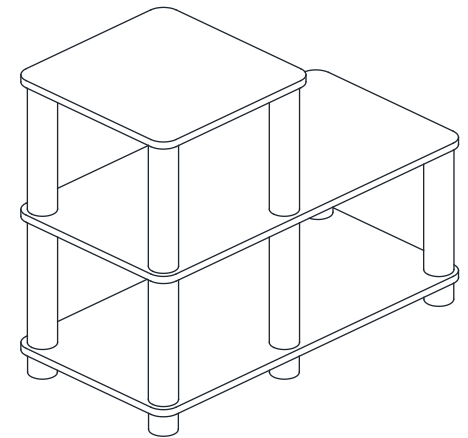

Recomm. 1 Person



No Tools Required



| No | Hardware List | Qty |
|----|--|-------|
| 1 | Round Pole  | 10pcs |
| 2 | Round Leg  | 6pcs |
| 3 | Round Ring  | 4pcs |

| No | Parts List | Qty |
|----|--|------|
| A | Top Panel  | 1pcs |
| B | Shelf Panel  | 1pcs |
| C | Bottom Panel  | 1pcs |

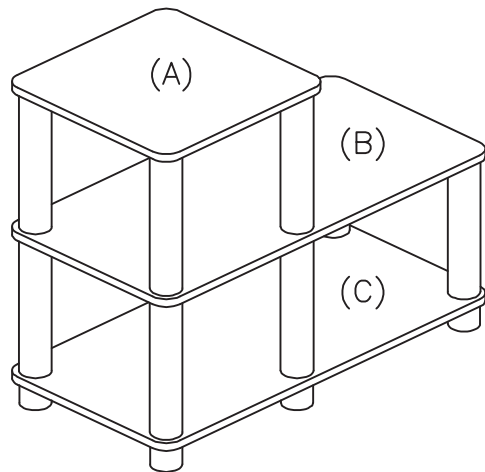

USEFUL HINTS BEFORE YOU START:

1. Read each step carefully before starting.
2. It is important that each step is performed in correct order to avoid difficulties.
3. Identify, sort and count the parts before assembly.
4. Assemble your furniture on packaging cardboard to prevent scratch or damage.
5. Clean the product with mild cleanser using soft damped cloth. Do not use harsh or abrasive cleanser.
6. Using incompatible hardware might cause damage to product.

STEP 1

Attach Round Pole(1) to Panel (A) and tighten it.

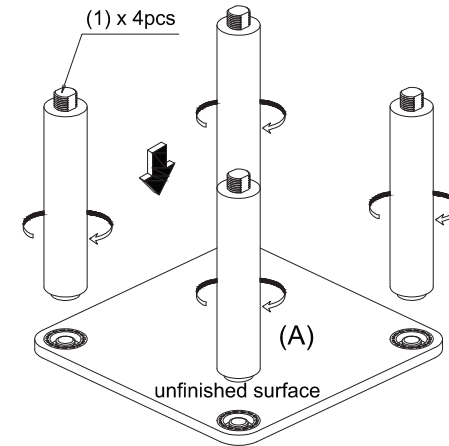

STEP 2

Tighten Pole(1) and Round Ring(3) to Panel (B), as shown:

