

# ASSEMBLY, MAINTENANCE, & **USER MANUAL**

MODEL #SSMSTR01

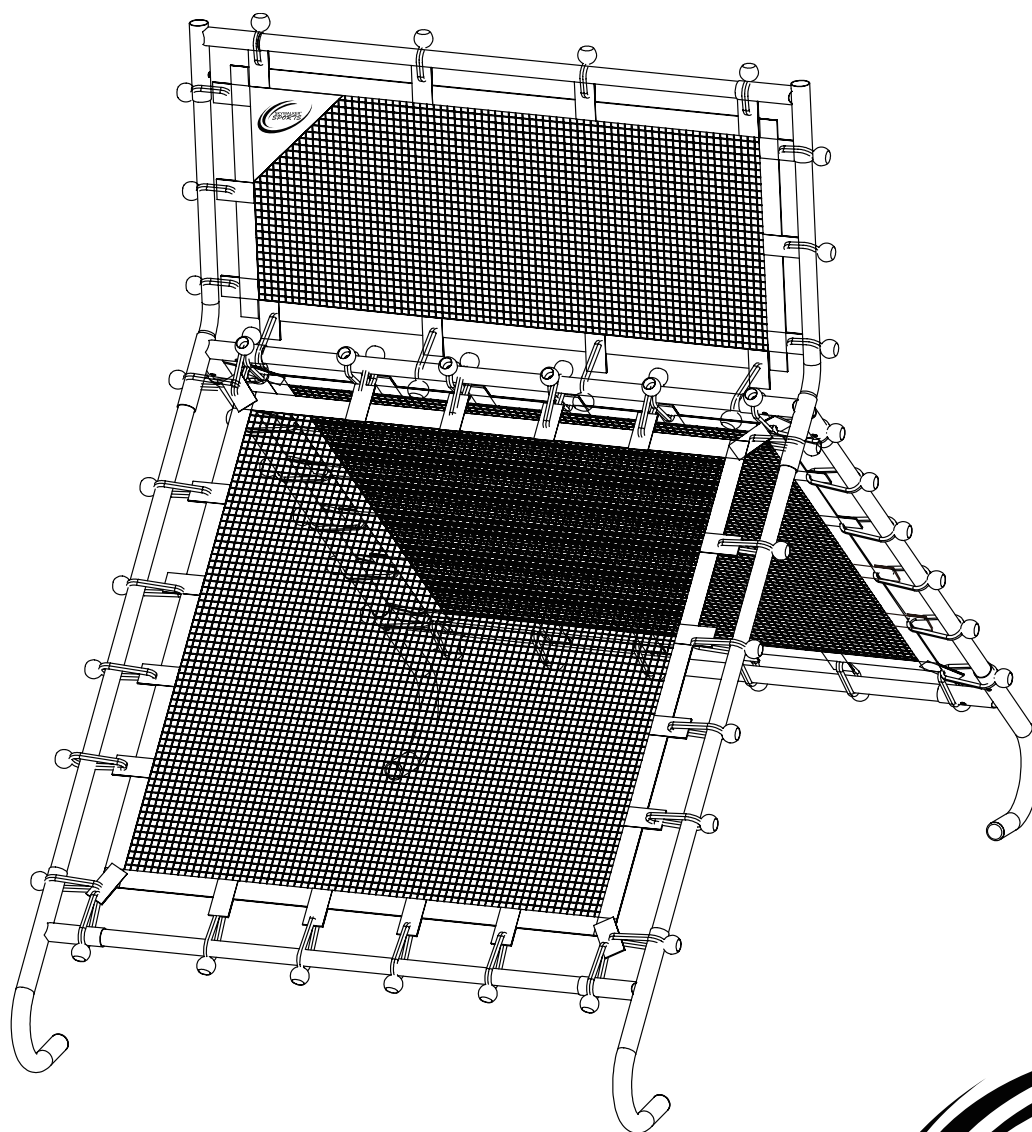

 **WARNING**

Read all precautions and instructions in this manual before using this equipment. Save this manual for future reference.



Skywalker Holdings LLC  
P.O. Box 574, Brigham City, UT 84302

# TABLE OF CONTENTS

---

Part List.....3  
Part Identification.....4-5  
Exploded Drawing.....6  
Assembly.....7-13  
Maintenance and Care.....14  
Warranty.....15-16



## STOP EVERYTHING YOU'RE DOING AND REGISTER YOUR PRODUCT.

Find our warranty registration online by typing in: [www.skywalkertrampolines.com/registration/](http://www.skywalkertrampolines.com/registration/)

You'll need to have the following information handy:

- Name
- Address
- Phone number
- Date of purchase
- Email address
- Product model number
- Product serial number
- Retailer the trampoline was purchased from

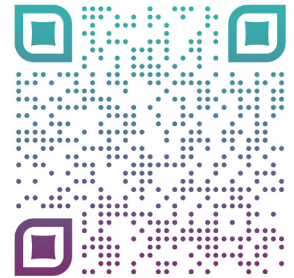

## HEY WE'VE GOT SOMETHING REALLY IMPORTANT TO SAY

Skywalker Sports belongs to a family of brands focused on providing active products. Check us out online! We've got **assembly videos** (for those of you who prefer movies over books), **FAQs** (so you know you're not the only one who needs help), **additional products** (including trampolines, playground, sports, and fitness equipment), and most importantly, find us on social media! Because we want to be your friend. **We'd love to see how you are using our products!**



@skywalkertrampolines



skywalkertrampolines



@skywalker\_trampolines



@swtrampolines



@swtrampolines



[www.skywalkertrampolines.com](http://www.skywalkertrampolines.com)



### WARNING

CHOKING HAZARD- Small parts not for children under 3 years.



### WARNING

Adult assembly required.

# PART LIST

---

Key No.	Qty.	Description
1	1	Left Joint
2	1	Right Joint
3	2	Left Leg
4	2	Right Leg
5	8	Straight Tube
6	2	Lower Net
7	62	Elastic with Ball
8	6	D28 End Cap <b>(Pre-installed)</b>
9	2	Pegs
10	2	D25 End Cap <b>(Pre-installed)</b>
11	2	Top Tube
12	2	Corner Joint
13	1	Upper Net
14	1	Bag

## ORDERING REPLACEMENT PARTS

We get it, sometimes things happen. But the fun shouldn't stop just because you need a new bolt or screw! To order replacement parts, check out our website at: [www.skywalkertrampolines.com](http://www.skywalkertrampolines.com) or call our toll-free Customer Care Hotline at **1-866-603-Jump (5867)**, Monday-Thursday, 8 a.m. to 5 p.m., Friday, 8 a.m. to 3 p.m. Mountain Time (excluding holidays).

Our customer service team will ask you a few questions in order to get the replacement part sent out as soon as possible. We're not trying to complicate your life, we promise.

When calling, make sure to have the following information ready:

- The model # of the product (see the front cover of this manual)
- The key # and description of the part (see the part list on the next page)
- The quantity needed (only you know the answer to that one!)

## BEFORE YOU BEGIN

Thanks for choosing Skywalker Sports! We're just as excited as you are to help your family live an active (but most importantly **FUN**) lifestyle. This model is one of our favorites, and we're confident you'll love it too. To make things easier for you, we've listed important information that you need to know. Make sure you brush up on the warnings, instructions, assembly, maintenance, and use of your new product because there will be a pop quiz at the end (Okay, not **REALLY**, but if you're still reading this, props to you! You're awesome.).

# PART IDENTIFICATION

Before you begin, take a look at the drawings below to make sure you have all the parts! The numbers in the squares to the left (key numbers) will help you identify the parts during assembly.

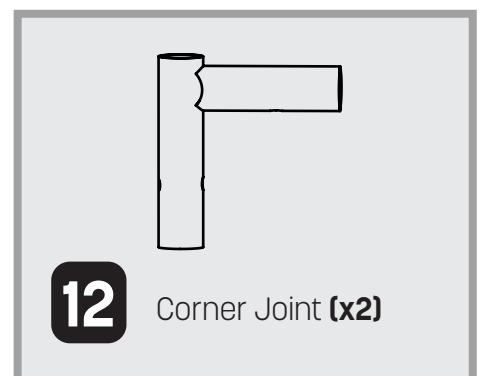
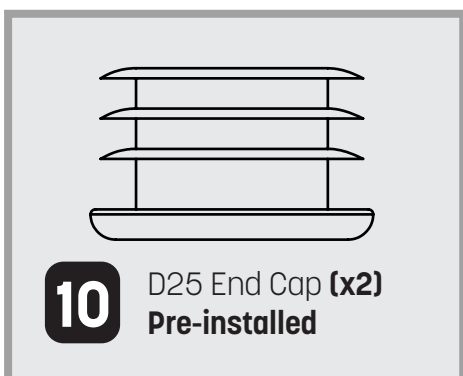
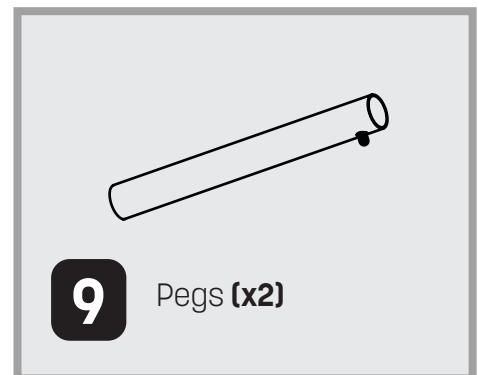
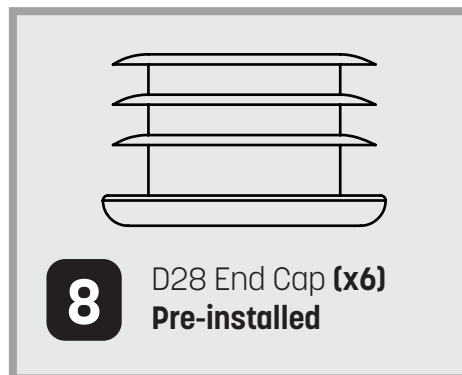
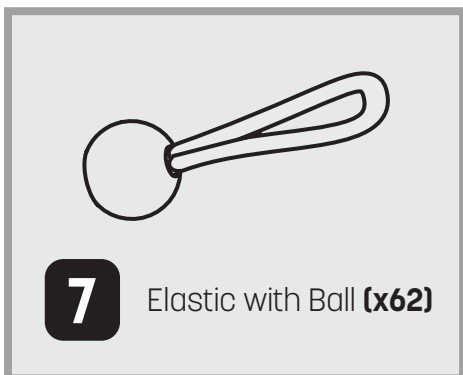
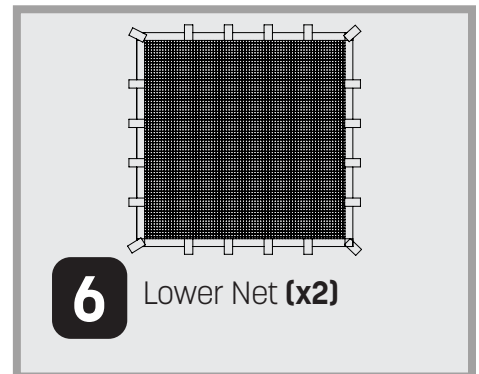
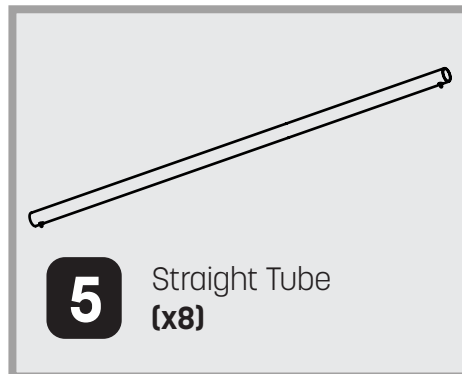
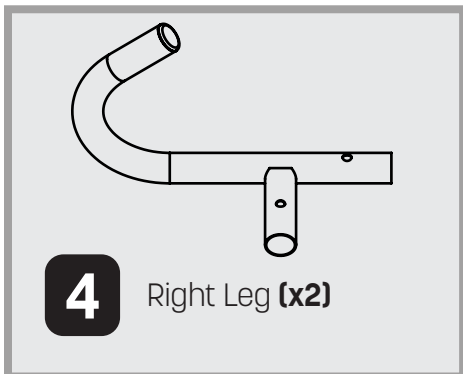
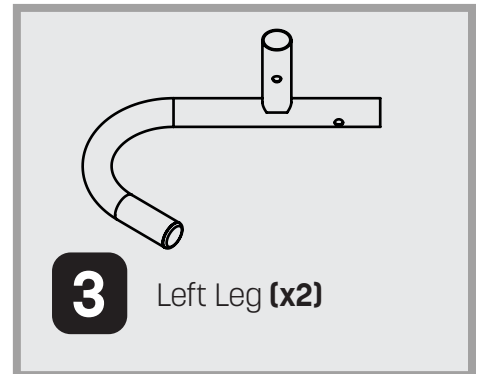
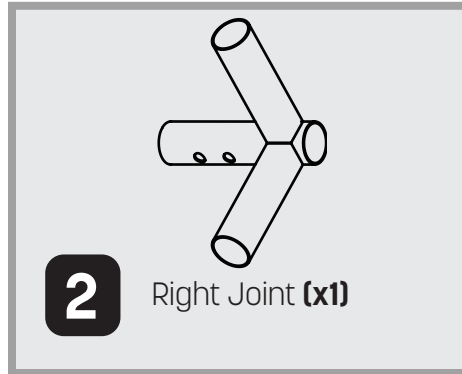
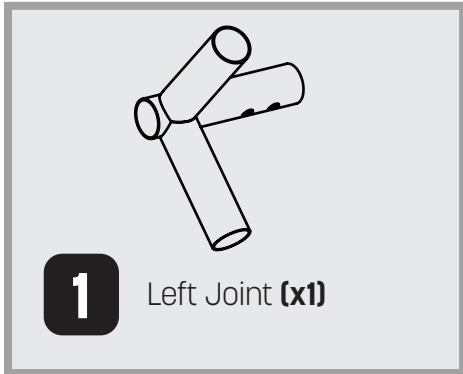

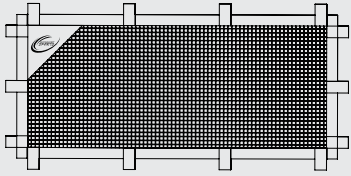

**13** Upper Net (x1)

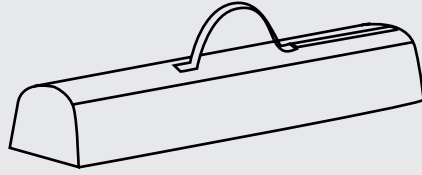

**14** Bag (x1)

# EXPLODED DRAWING

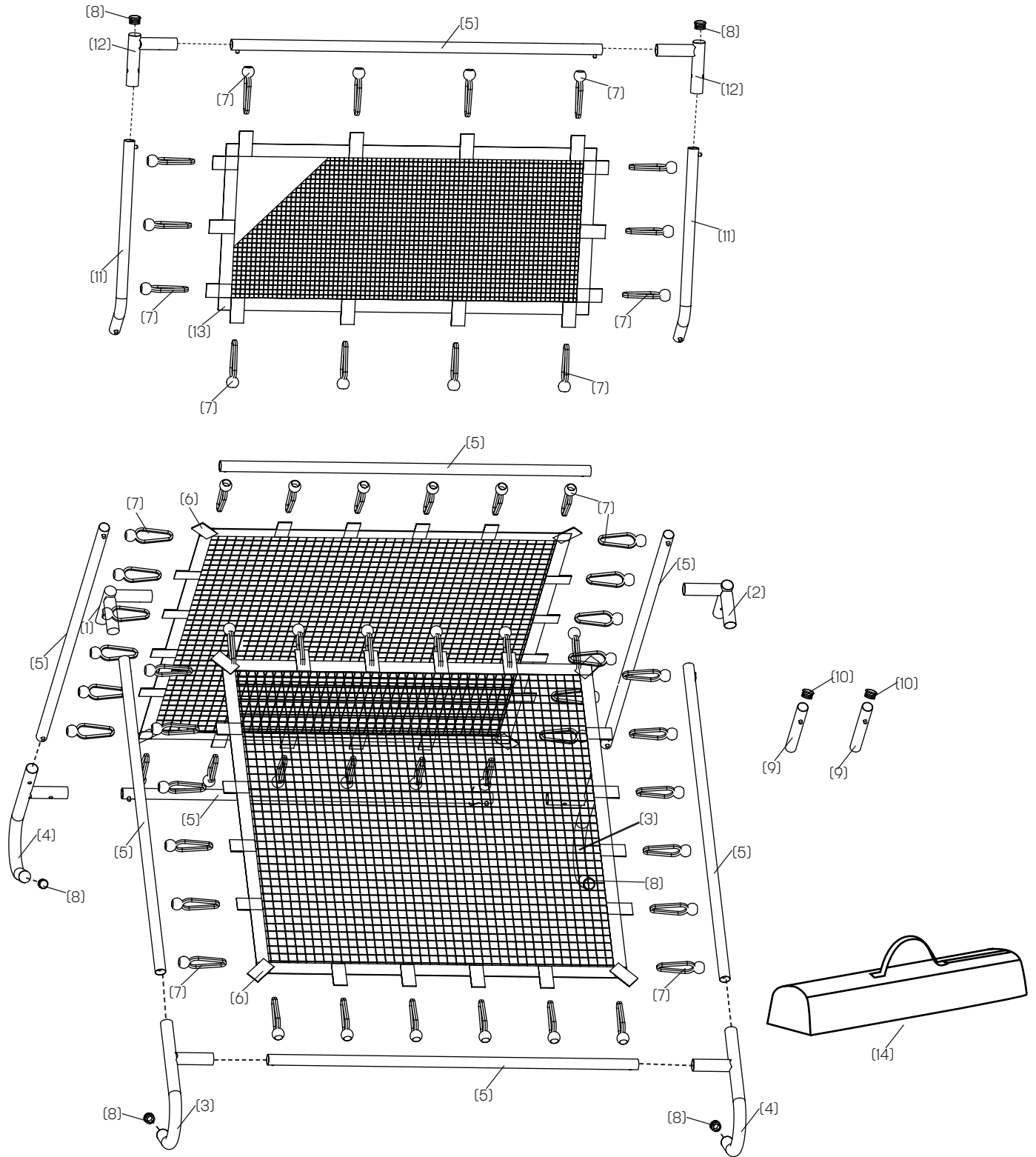

# ASSEMBLY

## READ THIS BEFORE YOU BEGIN

- The assembly steps refer to parts by their descriptions and key numbers (see the part list on page 3).
- The assembly steps are written in a specific order, and if you don't follow them exactly, you may end up having to start all over again.
- Most importantly, this may not be the easiest thing you've ever done, but it will be **worth it**. Trust us.

If you're a visual learner, check out our assembly videos!



skywalkertrampolines

## STEP 1

Register your Rebounder! For info on **warranty registration**, see page 2.

## STEP 2

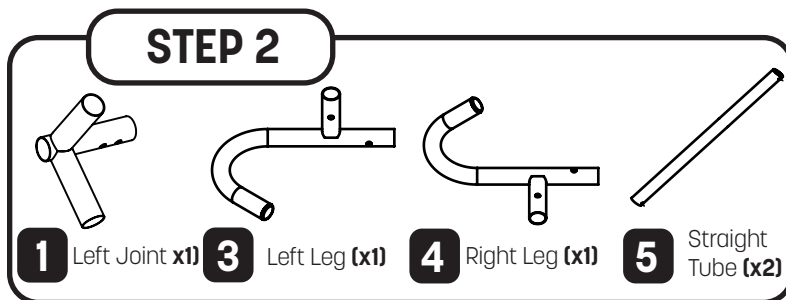

Locate the left joint **(1)**. With the two holes facing down and the extended pieces of the left joint facing you, attach a straight tube **(5)** to the left side of the left joint. Now connect the left leg **(3)** to the bottom of the straight tube you just attached. Connect the remaining straight tube to the bottom of the left joint **(into the first hole)**. Now, connect the right leg **(4)** to the bottom of that straight tube as shown.

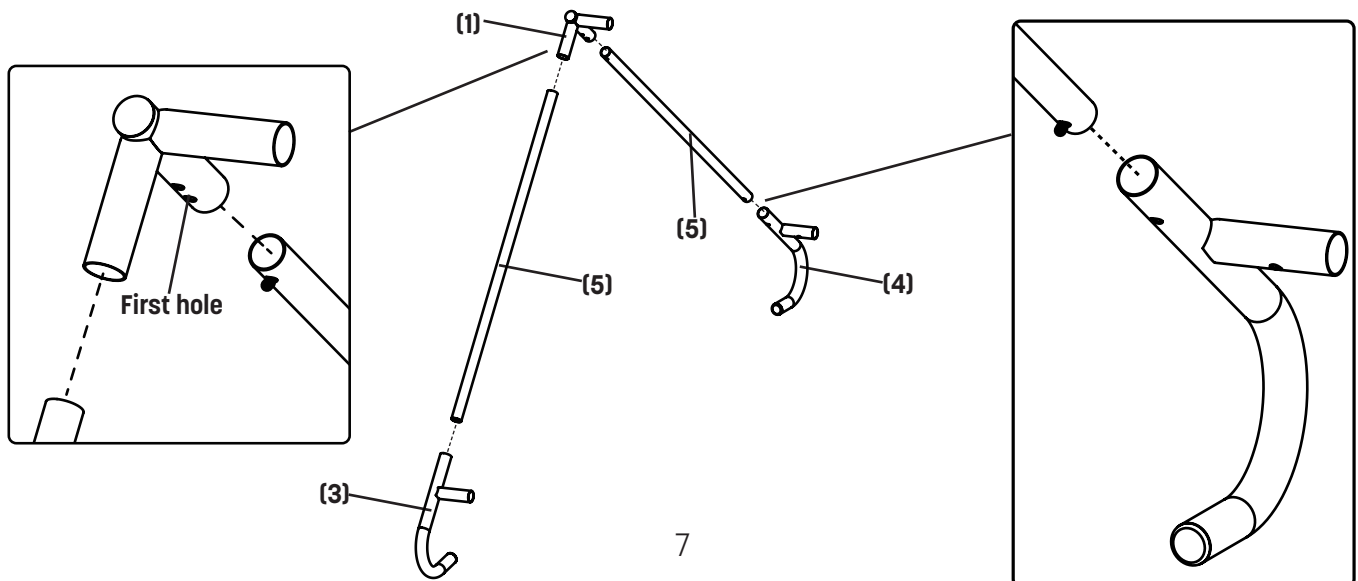

# ASSEMBLY

## STEP 3

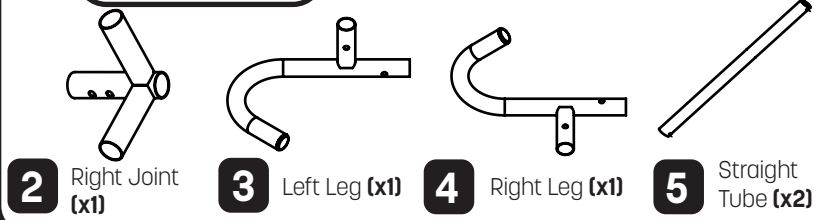

Using the right joint **(2)**, attach a straight tube **(5)** to the right side of the joint and then attach the right leg **(4)** to that straight tube. Now, attach the remaining straight tube **(5)** into the bottom of the right joint **(2)** (into the **first hole**). Then attach the left leg **(3)** to that straight tube as shown.

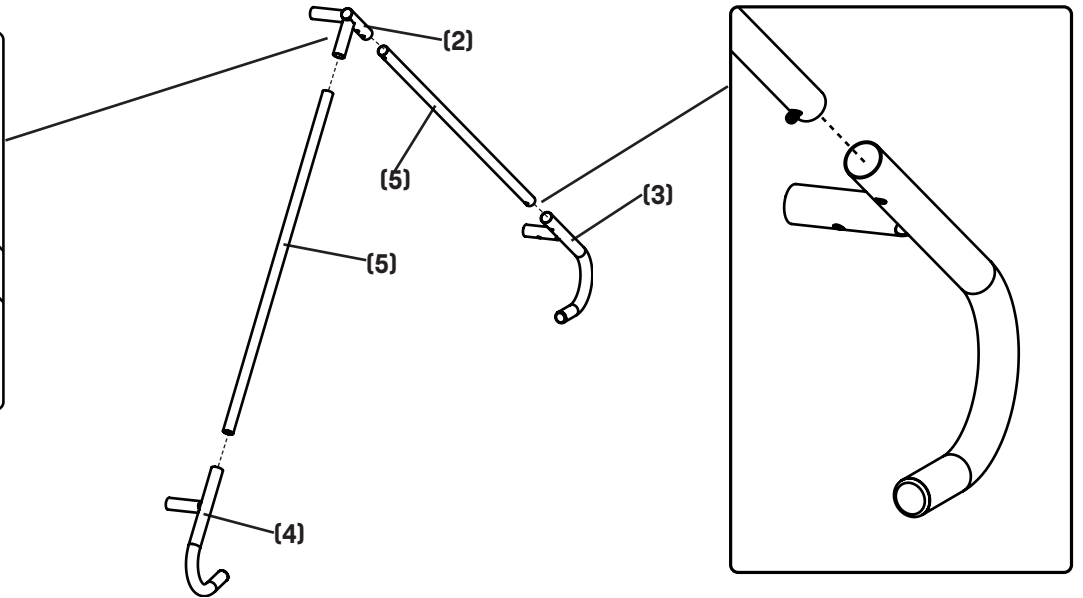
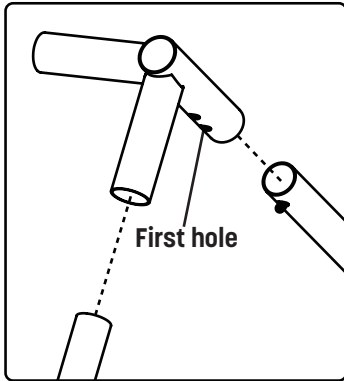

## STEP 4

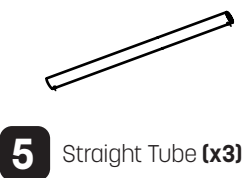

Attach the two pieces assembled in steps one and two with three straight tubes **(5)** as shown below.

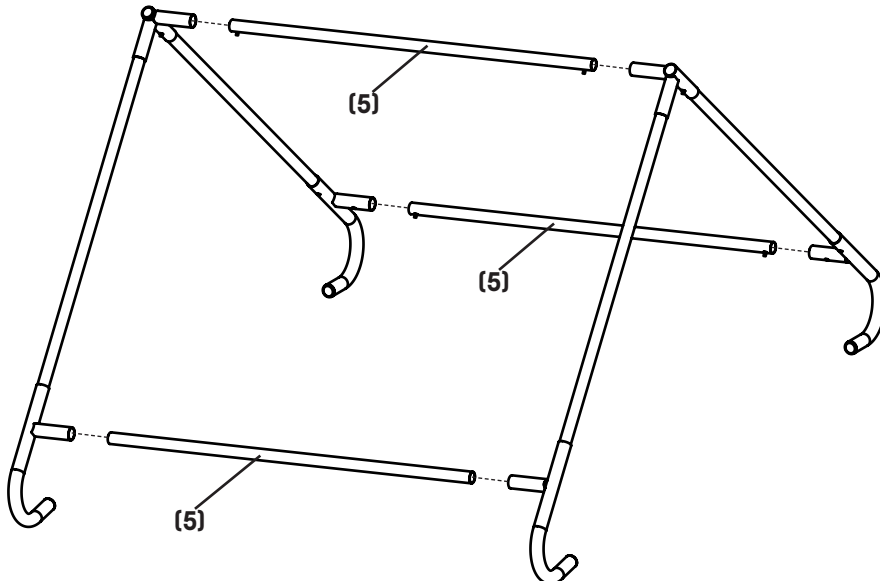



## STEP 5

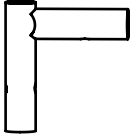

**12** Corner Joint  
(x2)

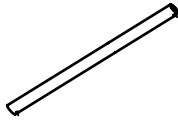

**5** Straight Tube  
(x1)

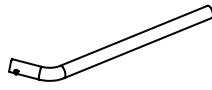

**11** Top Tube  
(x2)

Slide the short side of the two corner joints **(12)**, onto both ends of a straight tube **(5)**. Then insert two top tubes **(11)** into the long sides of the corner joints **(12)**. Make sure the bends of both top tubes are facing out.

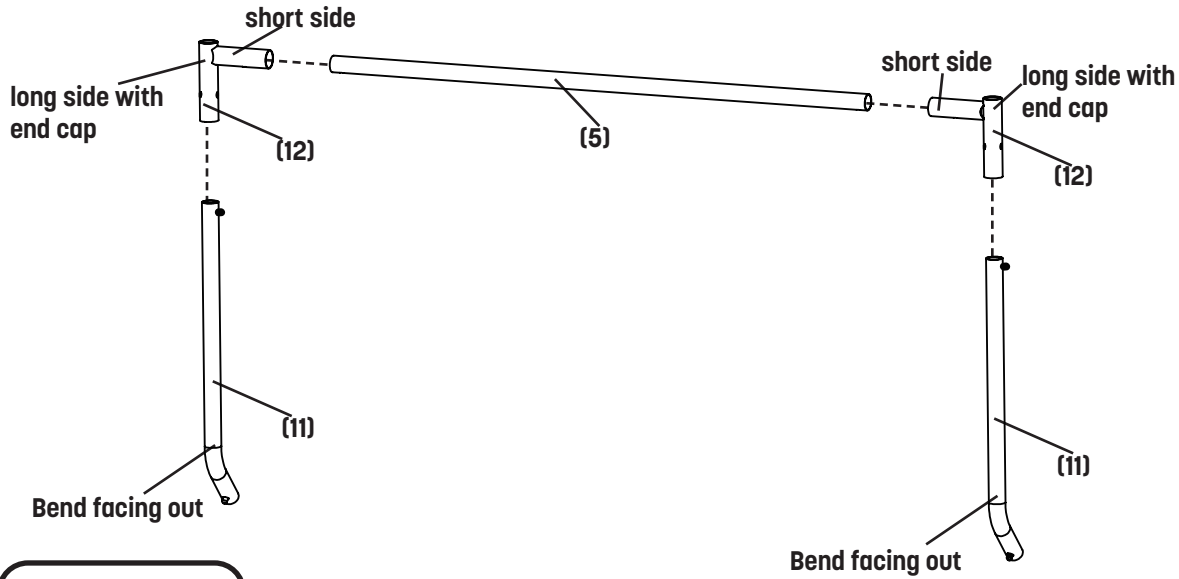

## STEP 6

Now, take the assembled piece from step 5 and insert it into the right and left joints of the assembled section from step 4.

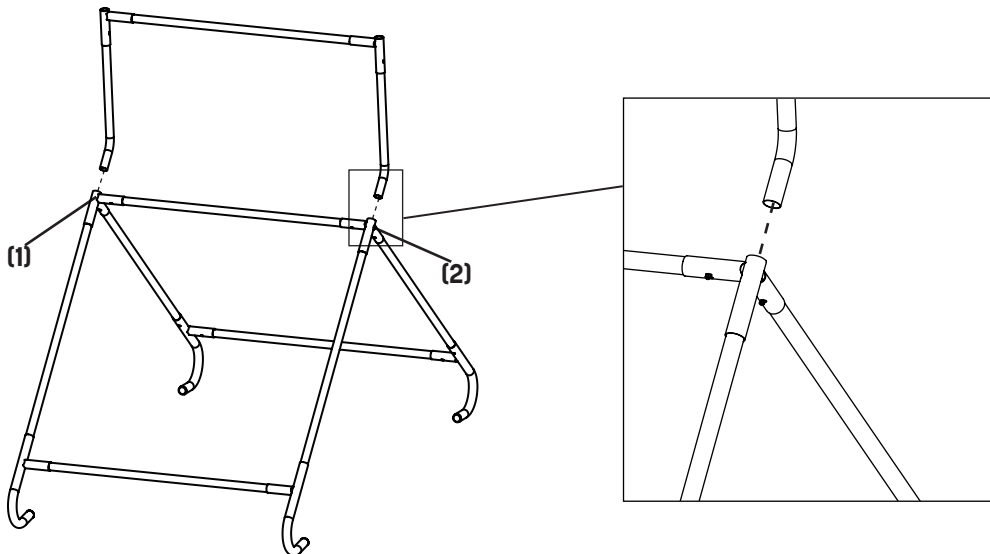

# ASSEMBLY

## STEP 7

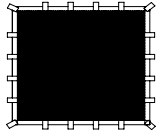

**6** Lower Net (x1)



**7** Elastic with Ball (x2)

Attach a corner of the lower net **(6)** to the frame by placing two elastics with ball **(7)** through the same tab then stretch to each side of the frame as shown below.

*Note: To attach the elastic with ball, hold the ball end at the bottom of the frame then thread the elastic through the tab. Pull the elastic over the top of the frame and loop over the ball to hold in place.*

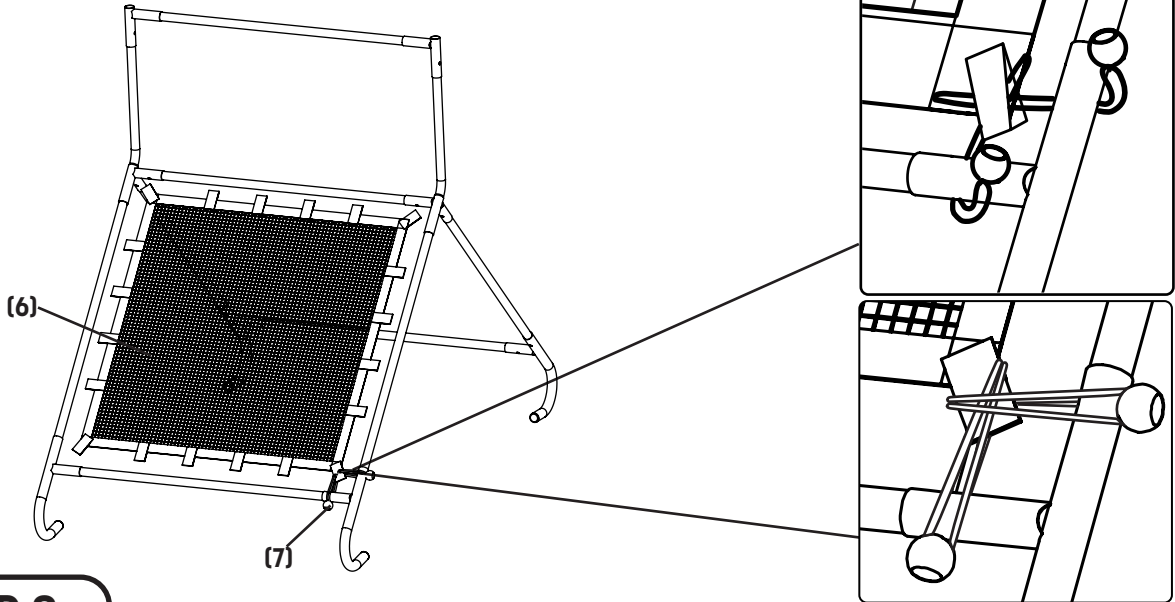

## STEP 8



**7** Elastic with Ball (x6)

Repeat step 7 to attach the three remaining corners of lower net **(6)** using six elastics with ball **(7)** as shown.

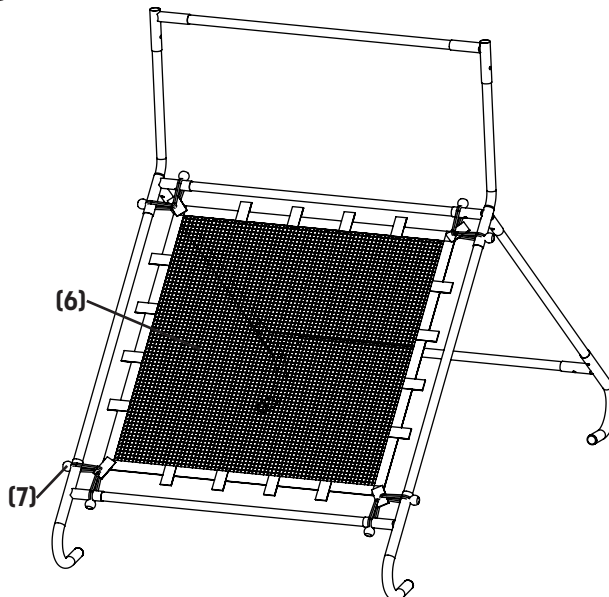

## STEP 9



**7** Elastic with Ball (x16)

Attach the remaining tabs of lower net **(6)** to the frame using the elastics with ball **(7)**.

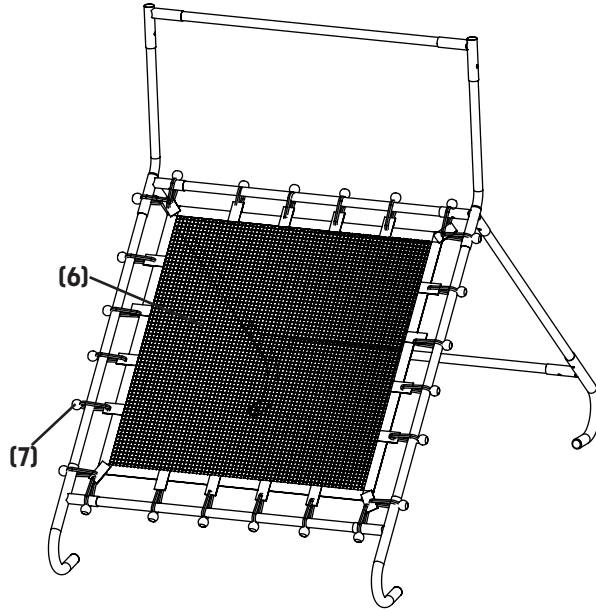

## STEP 10

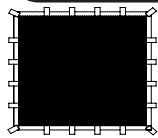

**6** Lower Net (x1)



**7** Elastic with Ball (x24)

Repeat steps 7-9 to attach the remaining lower net **(6)** to the opposite side of the frame.

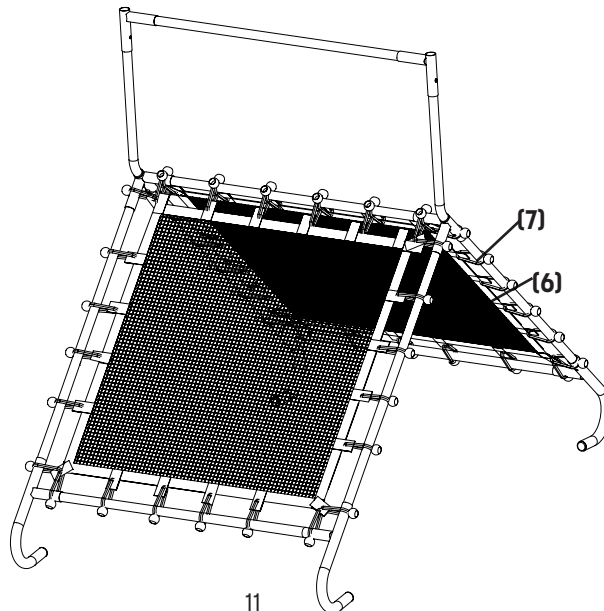

# ASSEMBLY

## STEP 11

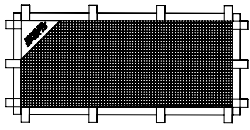

**13** Upper Net (x1)

**7** Elastic with Ball (x8)

Attach the corners of the upper net **(13)** to the upper portion of the frame using eight elastics with ball **(7)** as shown.

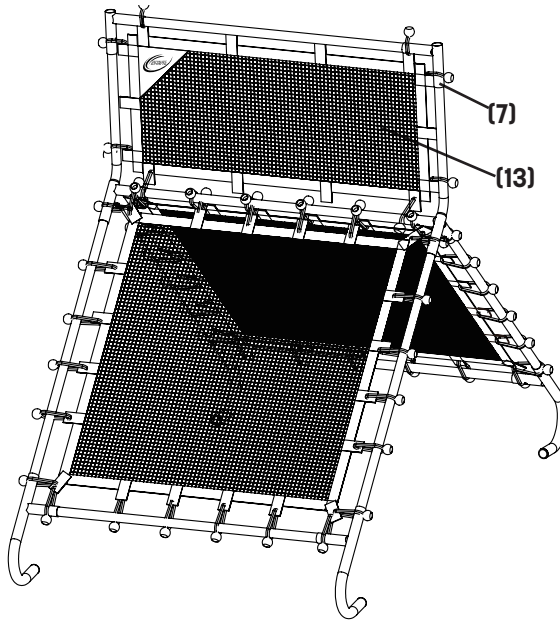

## STEP 12



**7** Elastic with Ball (x6)

Attach the remaining tabs to the upper part of toss back using elastics with ball **(7)**.

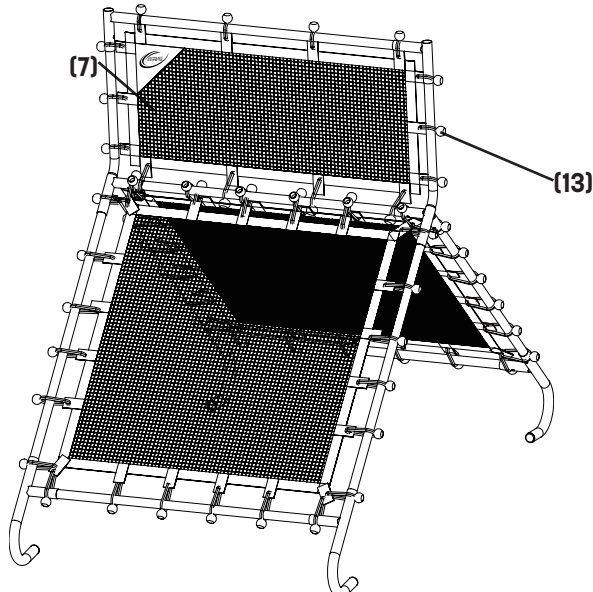

### STEP 13

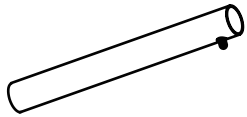

**9** Pegs (x2)

You can also choose to use just one panel of your Training Rebounder. To use this portion, remove one lower panel from the other sections of the training rebounder, keep the corner joints on the section you remove. Now place a peg **(9)** into each of the corner joints.

You can use the panel flat on the ground or at an angle with the hooked ends placed onto a trampoline frame, or another sturdy surface. Use this panel as a different way to practice or to play a game with friends.

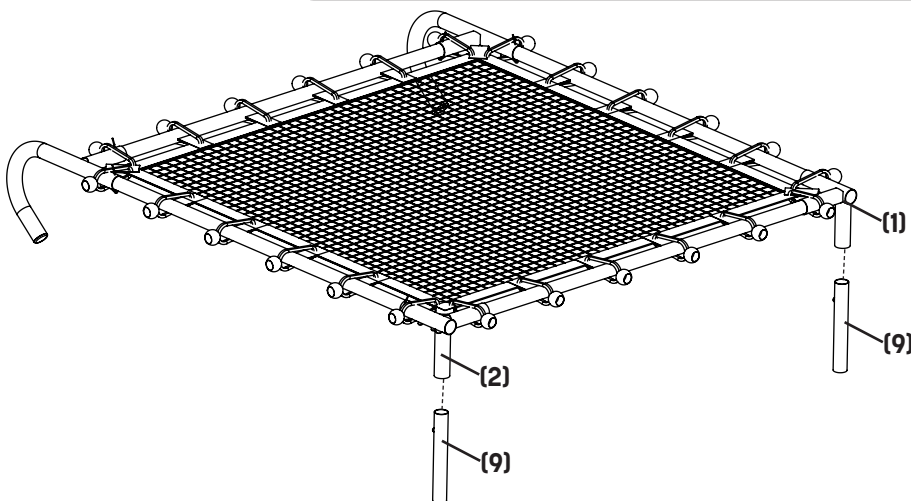

### STEP 14

Congratulations on completing your new Toss Game! So here comes the real question, **are you satisfied with this completed product?** If you are, go ahead and **write a review** on the retailer's site you bought it from. We'd really appreciate it, and if we could, we'd give you a gold star. Are you completely frustrated and have some choice words for us? Contact us directly! We're not trying to ruin your life, we promise. And we'll do everything we can to make it right again. See contact info on page 2-3.

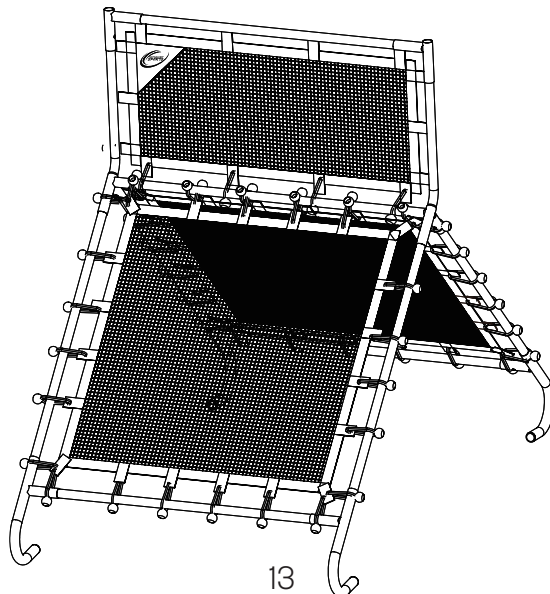

# MAINTENANCE & CARE INFORMATION

---

**Congratulations** and **high five** on successfully assembling your new Skywalker Sports Multi Sport Training Rebounder. Now, the best way to keep your new training rebounder in tip top shape, is to periodically check for:

- Missing, improperly positioned, or insecurely attached netting or frame pieces
- Punctures, frays, tears, or holes worn in the netting
- Deterioration in the stitching or fabric of the netting
- Bent or broken frame tubes or joints
- Sagging netting
- Sharp protrusions on any frame pieces.

If you notice any of the above conditions, please disassemble the product until new parts are ordered!

Don't forget to check us out online! **We'd love to hear from you.**



@skywalkertrampolines



skywalkertrampolines



@skywalker\_trampolines



@swtrampolines



@swtrampolines



www.skywalkertrampolines.com

# LIMITED WARRANTY

---

Skywalker Holdings, LLC warrants its products to be free from defects in material and workmanship under normal use and service conditions. **The steel frame is warranted for three (3) years after the date of purchase. All other parts are warranted for one (1) year after the date of purchase.** Warranty coverage extends only to the original retail purchaser from the date of original purchase. This warranty is only valid concerning products used for residential use. Products used for commercial use, such as schools and daycares, will not be covered.

## WHAT IS NOT COVERED?



**Weather Damage:** The warranty does not cover damage due to the effects or acts of nature, such as earthquakes, wind, hurricanes, tornadoes, lightning, rain, fire, snow, excessive heat and cold conditions and/or sun damage. During the winter months the soft materials will need to be removed and stored in a dry place out of the snow. If left unprotected in the winter months, some components may become damaged, voiding this warranty.



**Fading and Rust:** Our products are fully galvanized. Skywalker does not warranty against rust or corrosion. Some areas may have higher air salt content, higher humidity, heavier rain and heavier snow. Skywalker does not warranty against fading.



**Loss or Damage:** Loss or damage caused during shipping or caused by abuse, misuse, improper or abnormal usage or unauthorized repair are not covered by this warranty and may also void the warranty.



**Unauthorized Replacement Parts:** The warranty will become void if any defects or damages are associated with the use of unauthorized replacement parts. All replacement parts must be obtained from an authorized agent.



**Assembly Service:** The warranty does not cover acts or omissions provided by a third-party assembly service. It is the customer's responsibility to check all boxes and confirm all components are included and in their proper condition before installation occurs.

## INSPECTION AND REPLACEMENT PARTS:

1. Your product SHOULD BE INSPECTED UPON UNPACKING AND SET UP AND THEREAFTER ON A REGULAR BASIS. WORN, DAMAGED OR BROKEN PARTS SHOULD BE REPLACED IMMEDIATELY AND BEFORE USE.
2. Call the Skywalker Trampoline Customer Service Department at 1-866-603-5867 to file a warranty claim. Be prepared to provide the following information: name, shipping address, a copy of your original sales receipt, a brief description of the problem and cause, trampoline model number and serial number. We may also ask for photos of the damaged/defective parts.
3. After reviewing your information and examining your photos, Skywalker Trampolines will make the determination if this part is covered by this warranty. If so, a replacement part will be sent to you.

**NOTE:** All requested information must be provided in order to review your warranty claim.

To order replacement parts for your product please visit [www.skywalkertrampolines.com](http://www.skywalkertrampolines.com)

Skywalker Holdings, LLC, PO Box 574, Brigham City, UT 84302 USA.

Printed in China © 2020 Skywalker Holdings, LLC

**NOTE:** SKYWALKER HOLDINGS, LLC IS NOT RESPONSIBLE OR LIABLE FOR INDIRECT, SPECIAL OR CONSEQUENTIAL DAMAGES ARISING OUT OF OR IN CONNECTION WITH THE USE OR PERFORMANCE OF THE PRODUCT OR OTHER DAMAGES WITH RESPECT TO ANY ECONOMIC LOSS, LOSS OF PROPERTY, LOSS OF REVENUE OR PROFITS, LOSS OF ENJOYMENT OR USE, COST OF REMOVAL, INSTALLATION OR OTHER CONSEQUENTIAL DAMAGES. SOME STATES DO NOT ALLOW THE EXCLUSION OR LIMITATION OF INCIDENTAL OR CONSEQUENTIAL DAMAGES. ACCORDINGLY, THE ABOVE LIMITATION MAY NOT APPLY TO YOU.

THE WARRANTY EXTENDED HEREUNDER IS IN LIEU OF ALL OTHER WARRANTIES AND ANY IMPLIED WARRANTY OF MERCHANTABILITY OR FITNESS FOR A PARTICULAR PURPOSE IS LIMITED IN ITS SCOPE AND DURATION TO THE TERMS SET FORTH HEREIN. SOME STATES OR COUNTRIES DO NOT ALLOW LIMITATIONS ON HOW LONG AN IMPLIED WARRANTY LASTS. ACCORDINGLY, THE ABOVE LIMITATION MAY NOT APPLY TO YOU. THIS WARRANTY GIVES YOU SPECIFIC LEGAL RIGHTS. YOU MAY ALSO HAVE OTHER RIGHTS WHICH VARY STATE TO STATE OR COUNTRY TO COUNTRY.

THIS WARRANTY IS VALID ONLY IN THE COUNTRY THE PRODUCT WAS PURCHASED.