

ASSEMBLY INSTRUCTIONS

- 3-Pieces
Bar Set

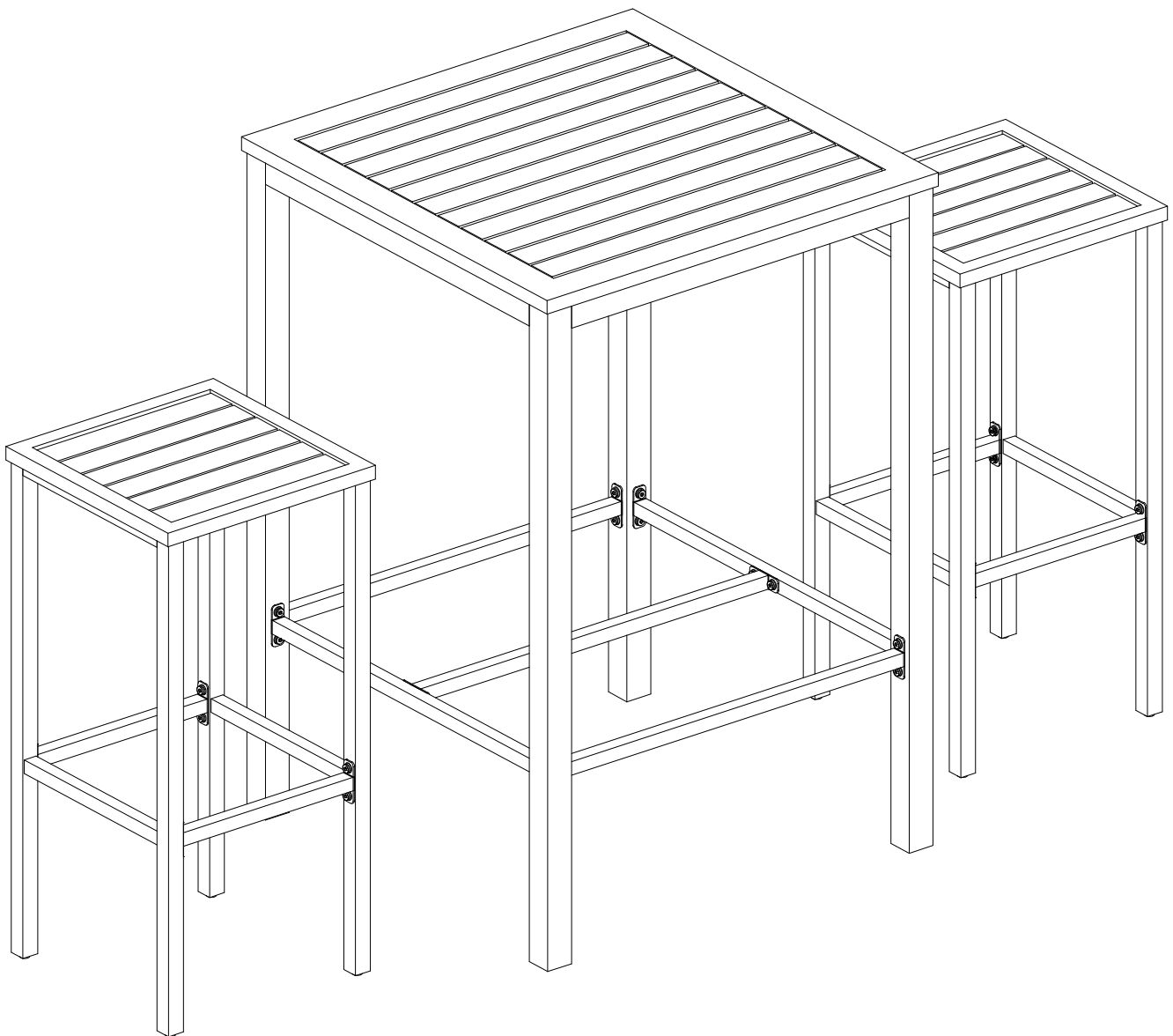

WARNING !



Notice:

1. 80% Tighten before fixing all screws, Allen wrench is recommended instead of an electric drill.
2. Place the item on a flat ground to adjust and make sure it remains stable.
3. Tighten up all screw with tools gradually.
4. If screw are not aligned with holes during assembly, please loosen all the other screws to 50% and continue the assembly process.
5. If the item is not stable, please loosen all screws, adjust it on a flat ground and tighten up all screws again.
6. Note: If one or some screws are fully tighten during assembly, chances are the others will not be aligned with holes. In addition, all the holes are designed to be relatively larger to provide more space for the adjustment of the screws.

PACKAGE CONTENT

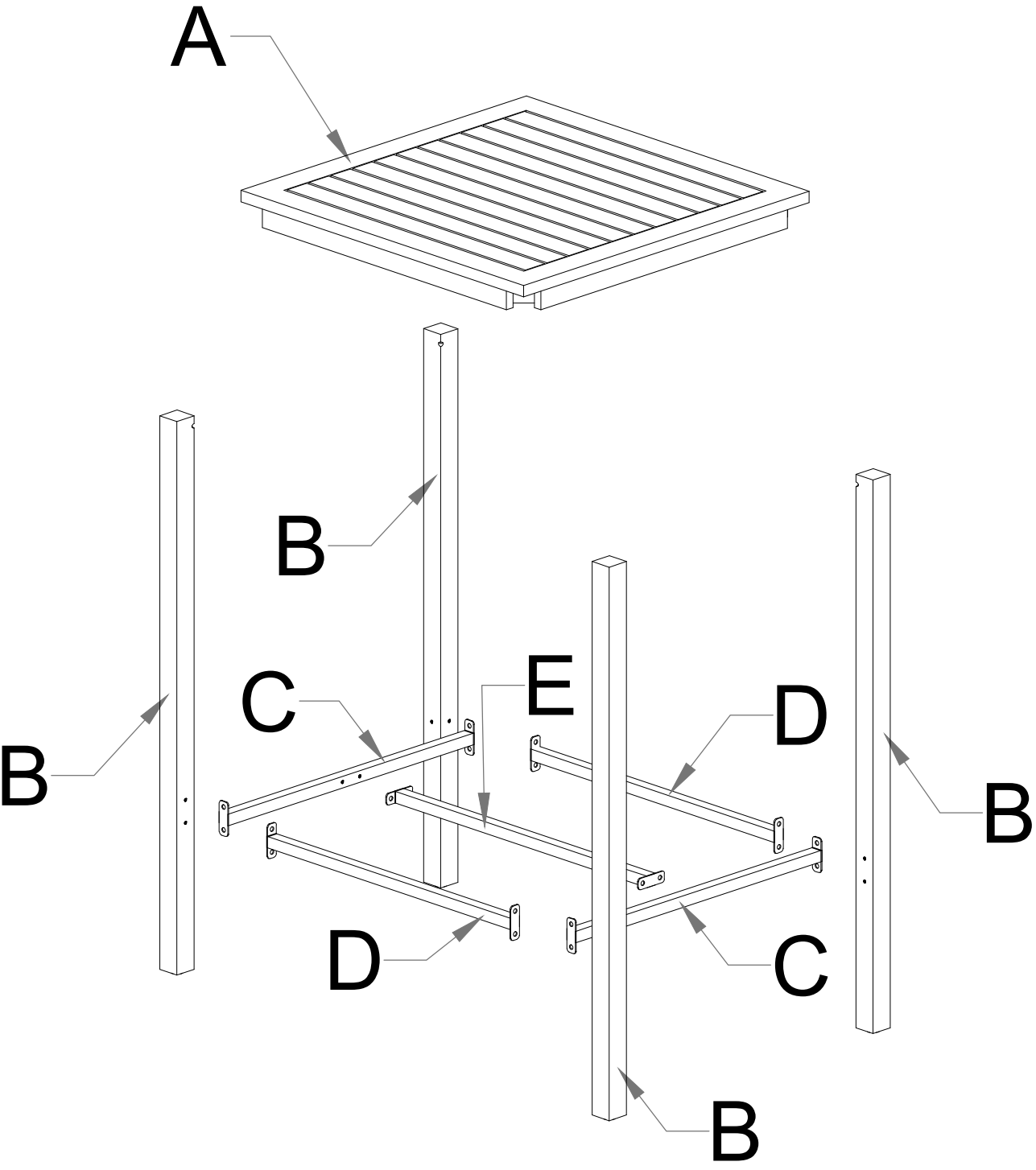

● x1-Table

PACKAGE CONTENT

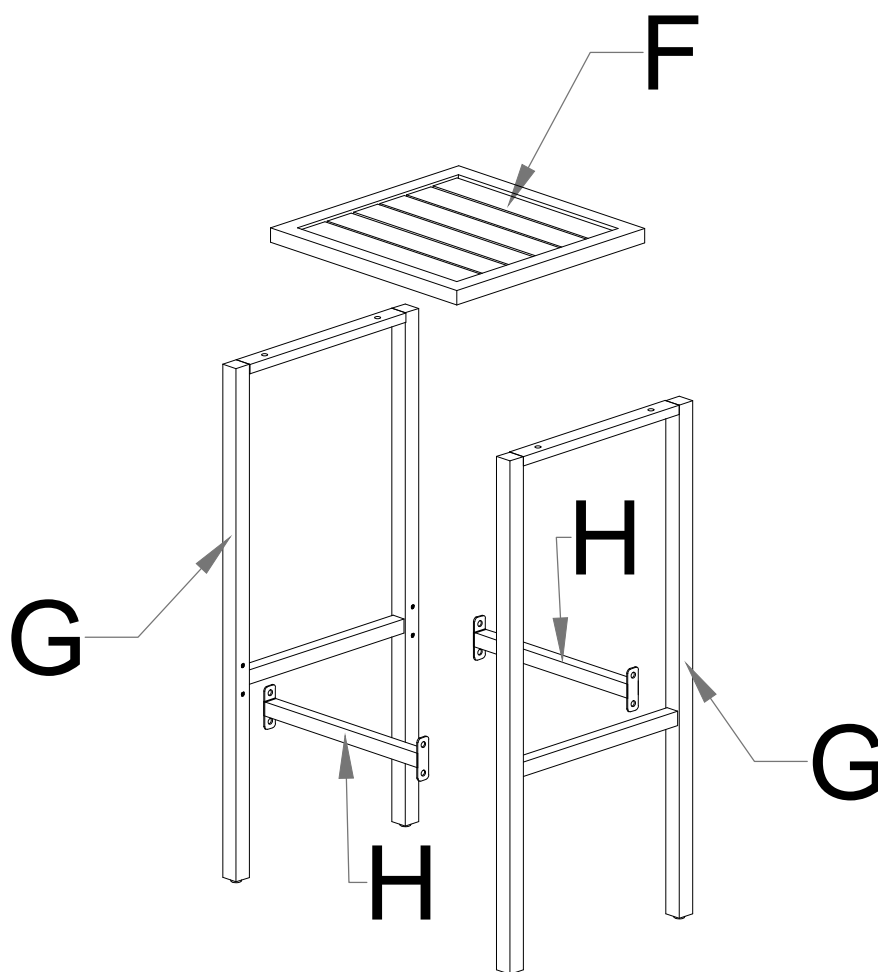

● x2-Chair

Partlist and Hardware List

A Table Top (1pc)

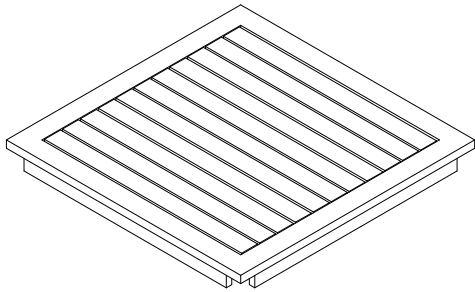

B Table Leg (4pcs)



C Table Support Frame C (2pcs)

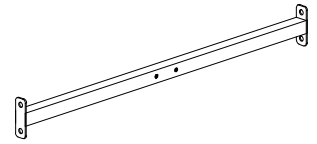

D Table Support Frame D (2pcs)

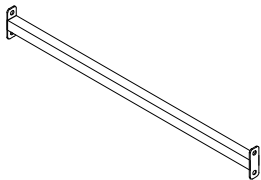

E Middle Table Support Frame E (1pc)

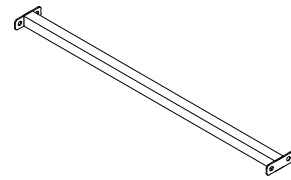

F Seat Chair Frame (2pcs)

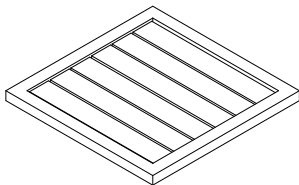

G Chair Leg (4pcs)

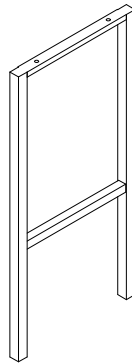

H Chair Support Frame H (4pcs)

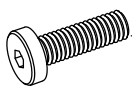
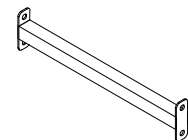

Bolt Ø6x20mm

1 x36+2

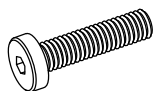

Bolt Ø6x30mm

2 x8+1

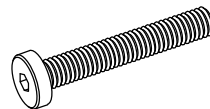

Bolt Ø6x45mm

3 x4+1



Flat Washer

4 x48+4



Allen Key

5 x2

Step 1

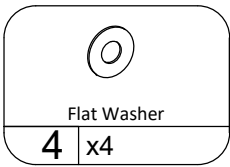
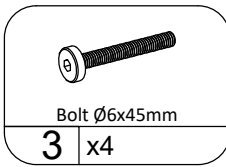
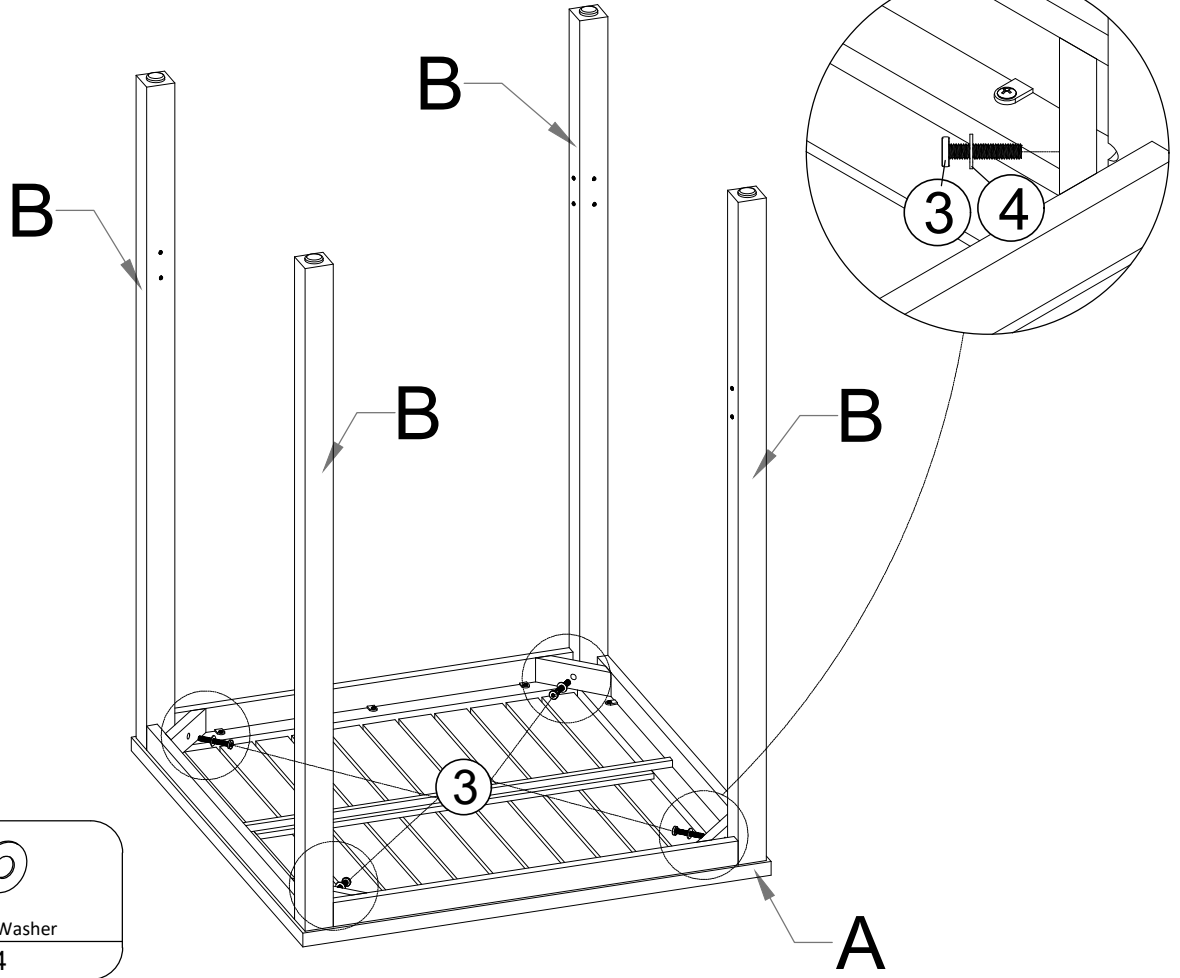
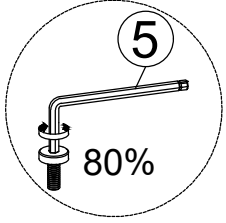

Step 2

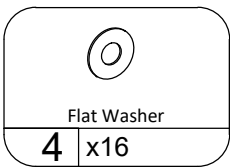
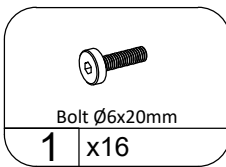
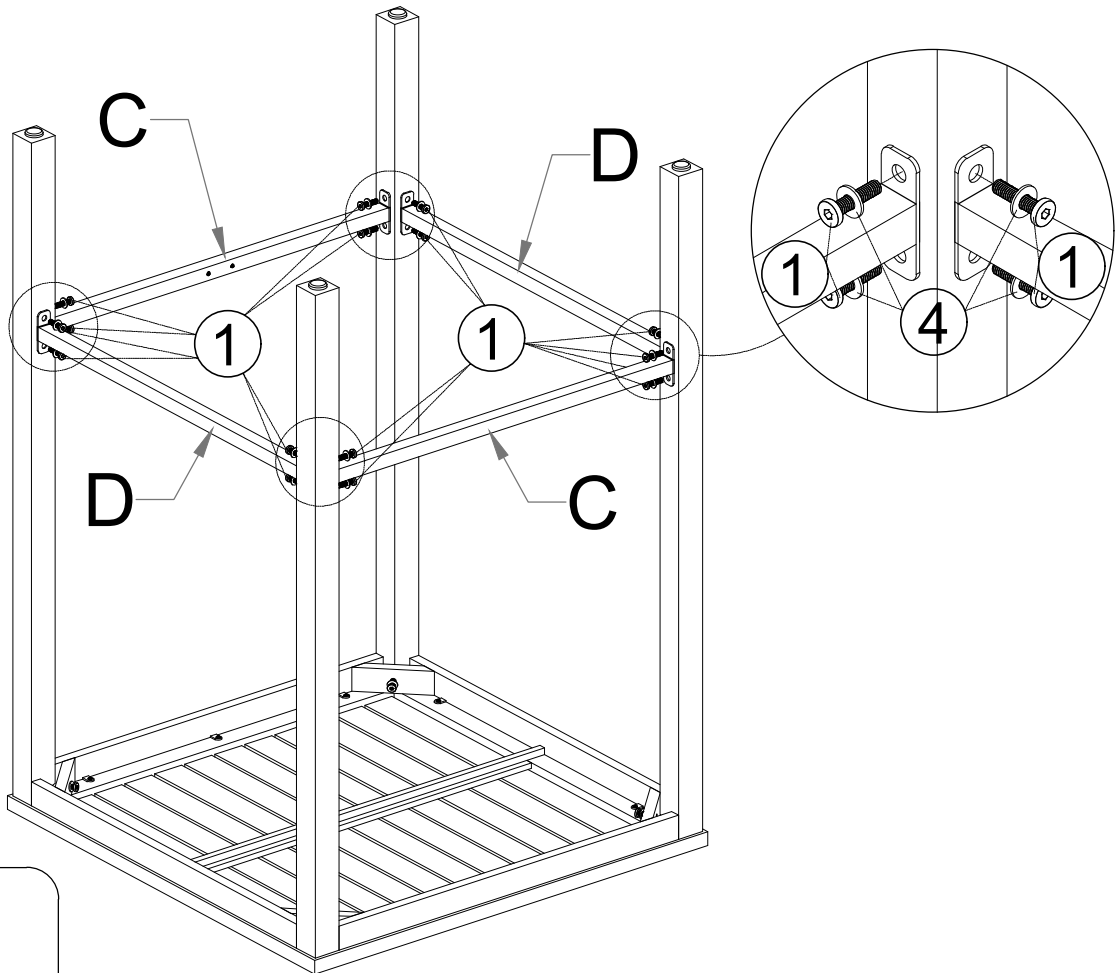
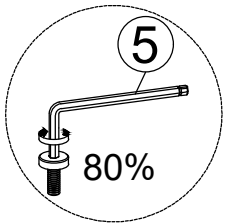

Step 3

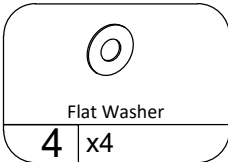
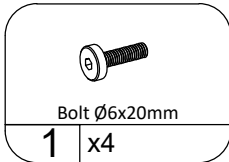
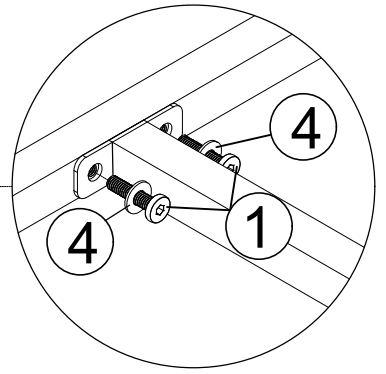
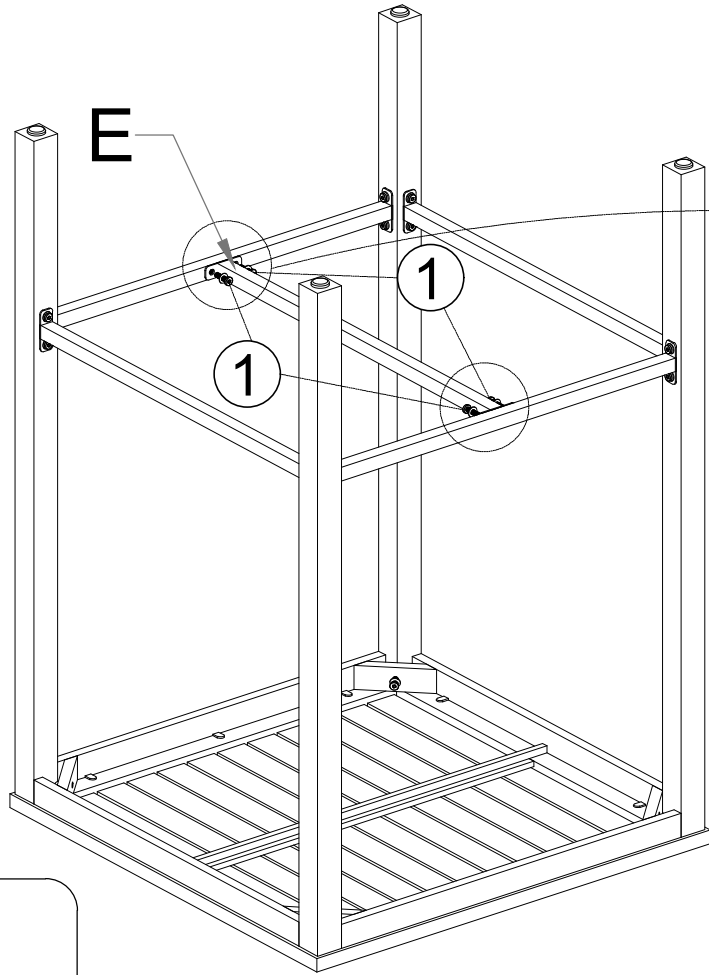
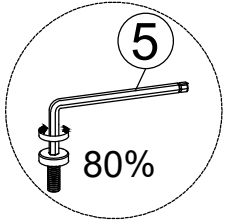

Step 4

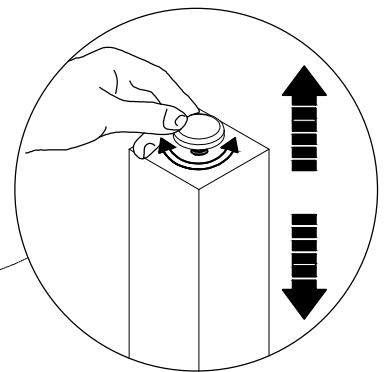
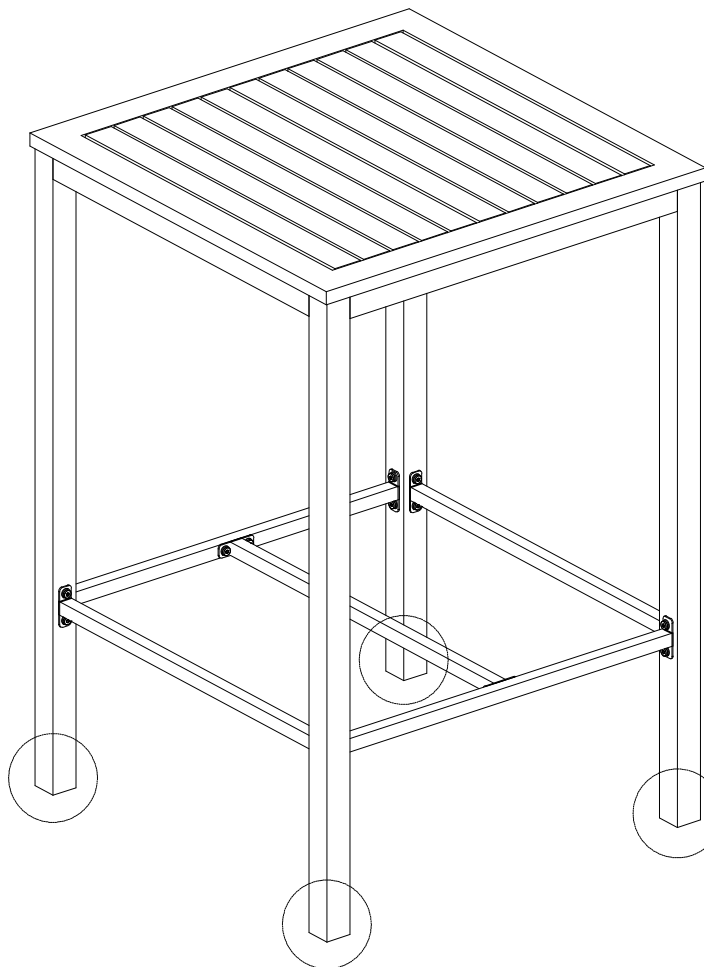
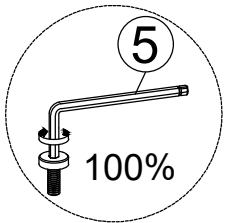

Put the Table upright and make sure all legs are level, then firmly tighten Bolts with Allen Key (5).

Step 5

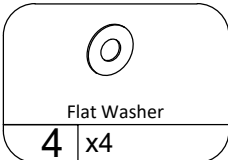
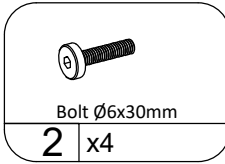
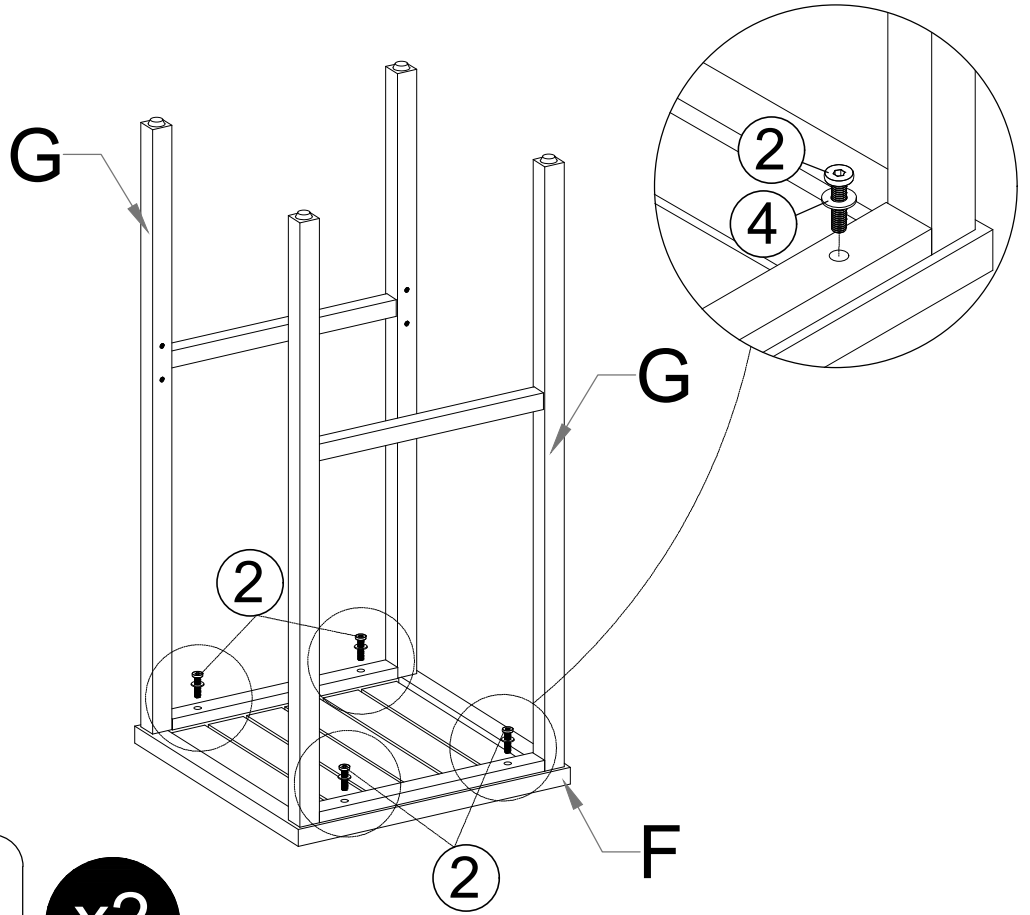
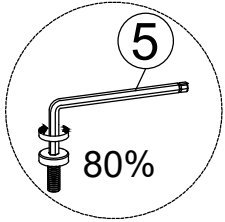

x2

Step 6

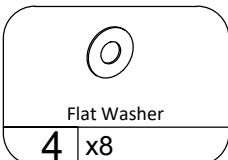
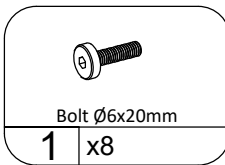
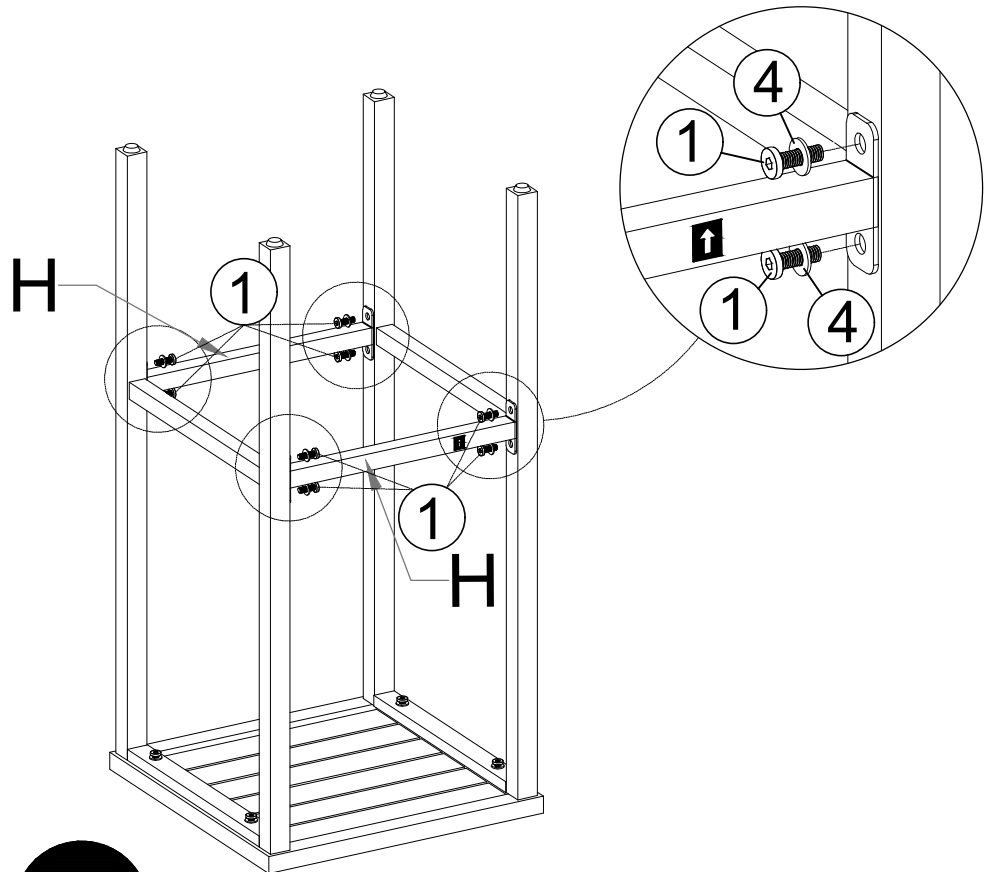
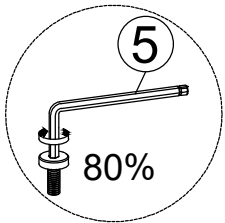

x2

Step 7

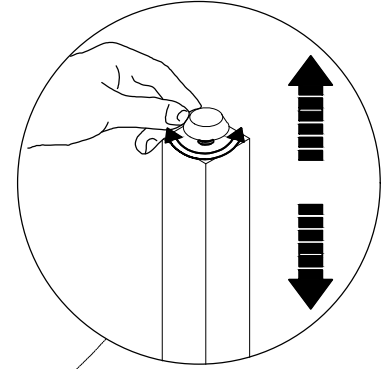
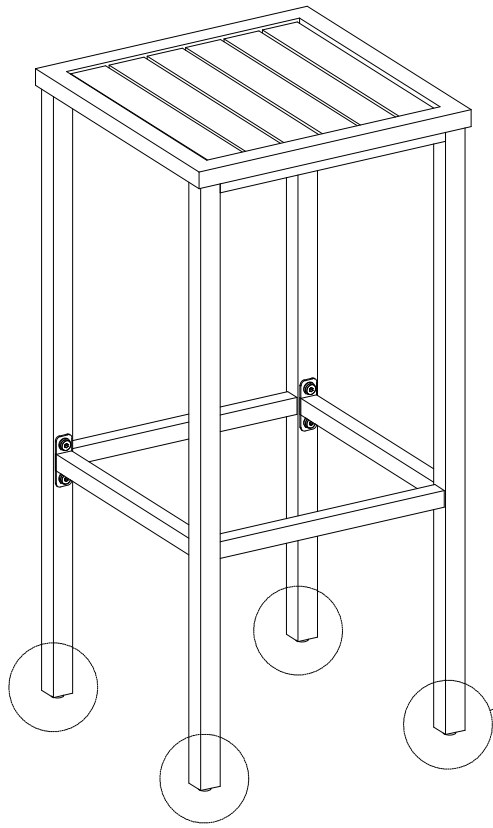
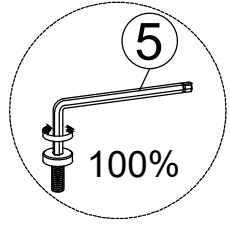

x2

Put the Chair upright and make sure all legs are level, then firmly tighten Bolts with Allen Key (5).

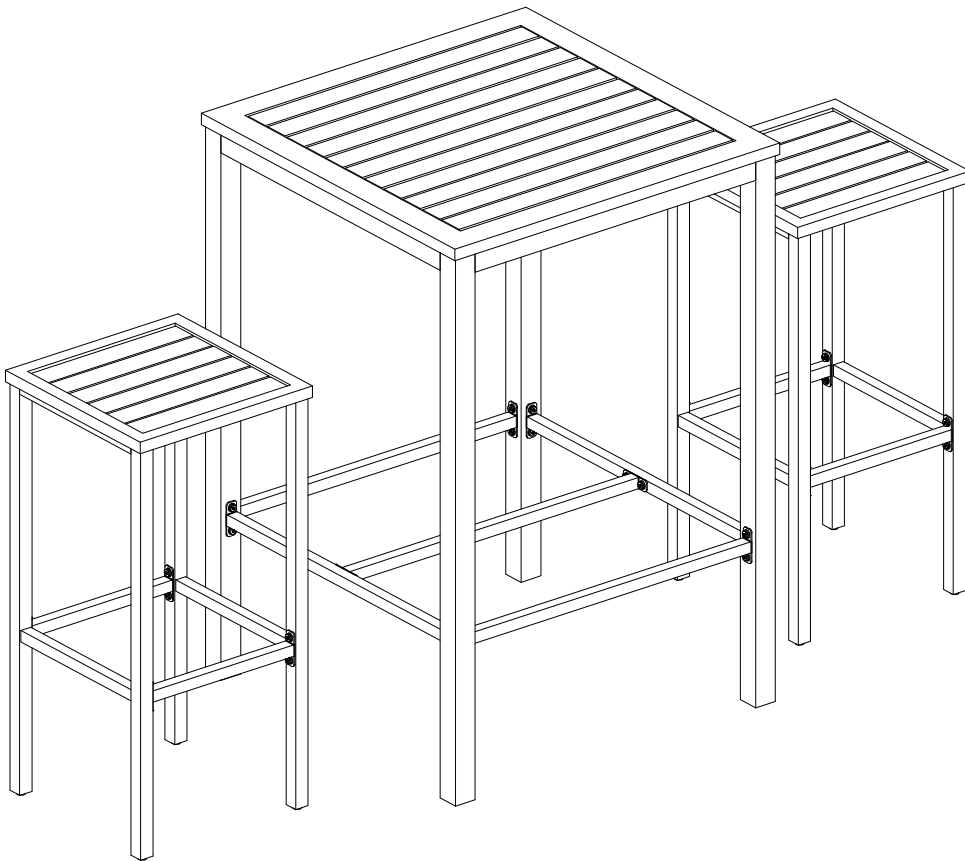

Finish