

ASSEMBLY INSTRUCTION

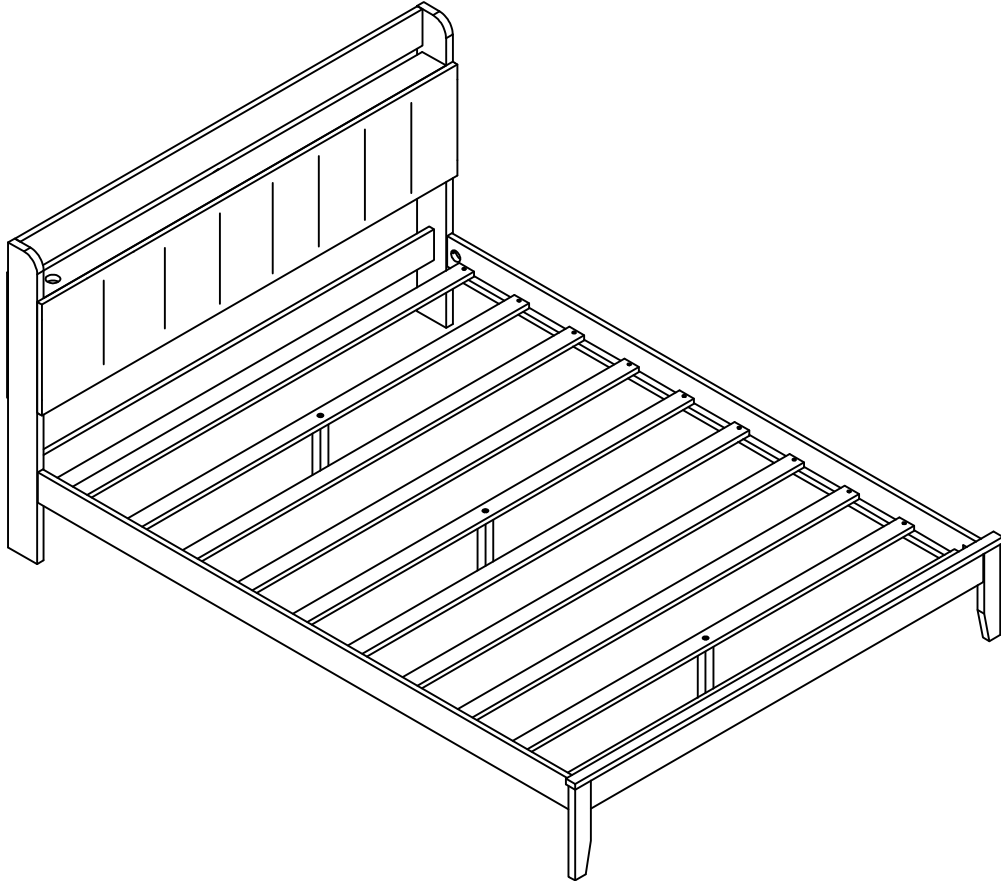







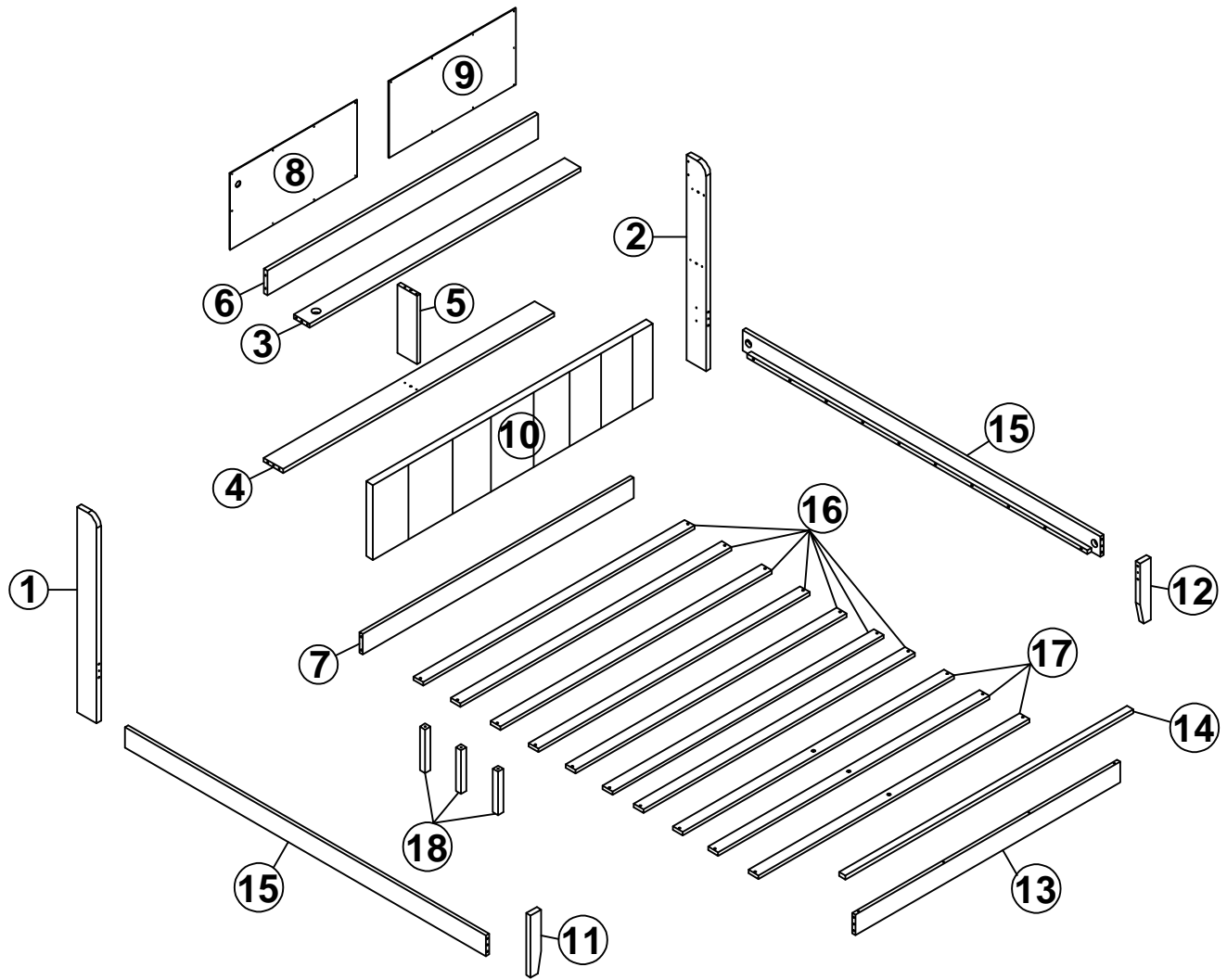

! SAFETY WARNINGS !

1. This bed is designed for use Queen Mattress 80 inch Long and 60 inch Wide
2. Always use the recommended size mattresses or mattress supports, or both, to help prevent the likelihood of entrapment or falls.
3. Do not allow horseplay on or under the bed and prohibit jumping on the bed
4. Do not use substitute parts. Contact the manufacturer or dealer for replacement parts.
5. Keep these instructions for future reference

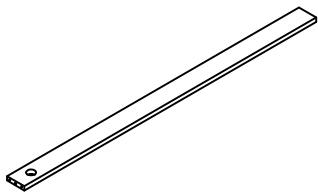
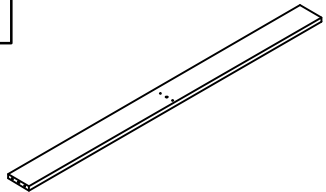
ASSEMBLY INSTRUCTION

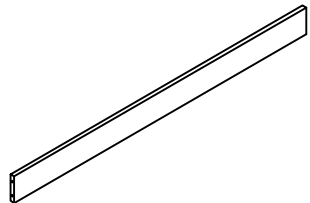
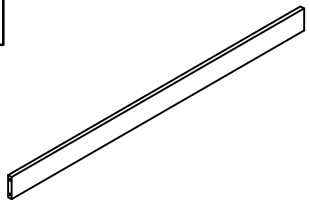
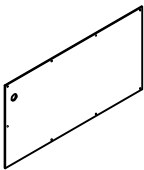
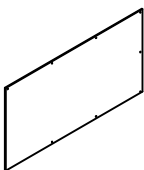
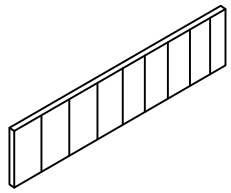

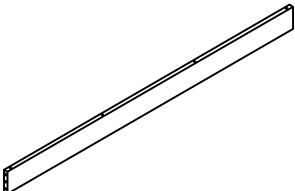
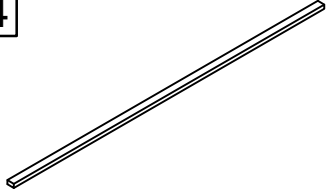
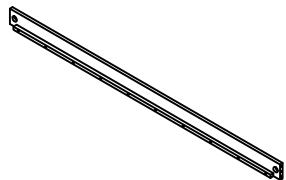
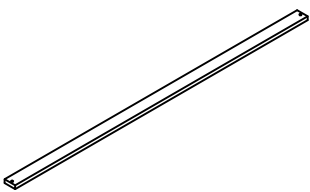
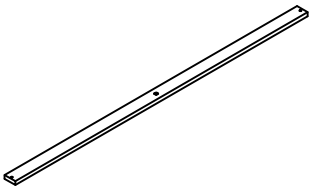



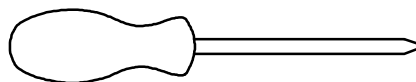





Part List

<p>1</p>  <p>Left-Front Leg - 1pc</p>	<p>2</p>  <p>Right-Front Leg - 1pc</p>	<p>3</p>  <p>Horizontal Bar - 1pc</p>
<p>4</p>  <p>Horizontal Bar - 1pcs</p>	<p>5</p>  <p>Vertical Bar - 1pcs</p>	<p>6</p>  <p>Horizontal Bar - 1pcs</p>
<p>7</p>  <p>Horizontal Bar - 1pcs</p>	<p>8</p>  <p>Right-Back Panel - 1pc</p>	<p>9</p>  <p>Left-Back Panel - 1pc</p>
<p>10</p>  <p>Open plate - 1pc</p>	<p>11</p>  <p>Left-Back Leg - 1pc</p>	<p>12</p>  <p>Right-Back Leg - 1pc</p>
<p>13</p>  <p>Horizontal Bar - 1pcs</p>	<p>14</p>  <p>Horizontal Bar - 1pcs</p>	<p>15</p>  <p>Side Panels - 2pcs</p>
<p>16</p>  <p>Slats - 7pcs</p>	<p>17</p>  <p>Slats Mount Leg- 3pcs</p>	<p>18</p>  <p>Support Leg - 3pcs</p>

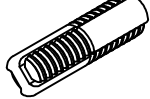

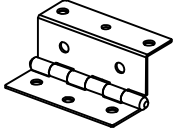
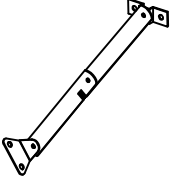
Assembly Tools Required (Not Included)

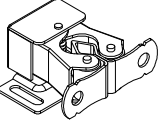
Hardware List

<p>A</p>  <p>Link 1 -20Pcs</p>	<p>B</p>  <p>Link 2 -20Pcs</p>	<p>C</p>  <p>Ø10 x 30 mm Wood Dowel 18pcs</p>
<p>D</p>  <p>Ø1/4" x 30 mm Hex-Head bolts 9pcs</p>	<p>E</p>  <p>M4 x 30 mm Wood Screws 20pcs</p>	<p>F</p>  <p>Link Latch 4Pcs</p>
<p>M</p>  <p>M3.5 x 15 mm Wood Screws 63pcs</p>	<p>N</p>  <p>Hinge 60mm -3pcs</p>	<p>T</p>  <p>Crankshaft -2pcs (L-R)</p>
<p>K</p>  <p>USB Power Socket 1pcs</p>	<p>P</p>  <p>Clamp pin (3pcs)</p>	<p>I</p>  <p>Allen Key 1pcs</p>

STEP 1: Following below illustration:

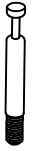

A

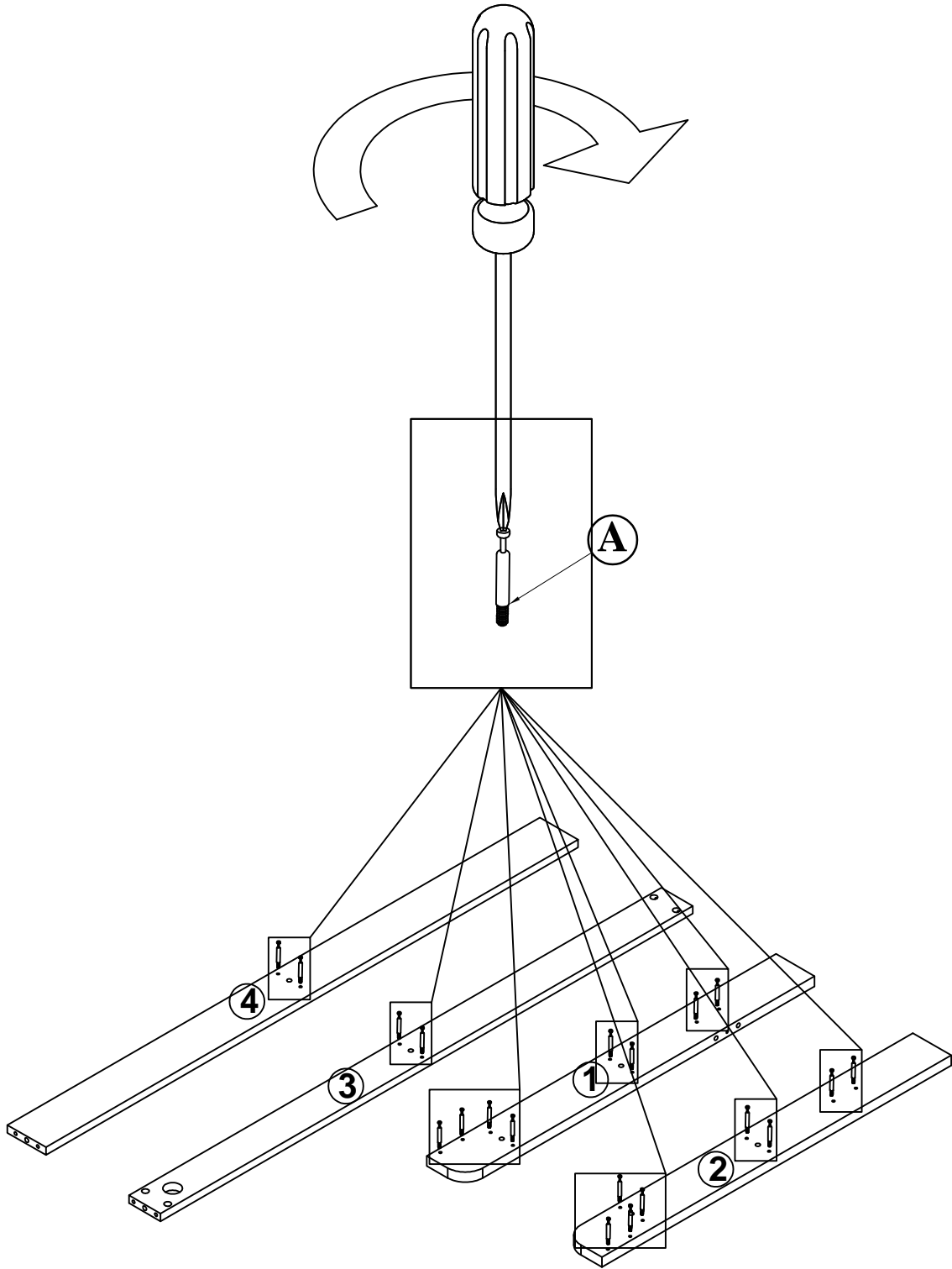

20pcs



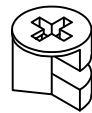

STEP 2: Following below illustration:

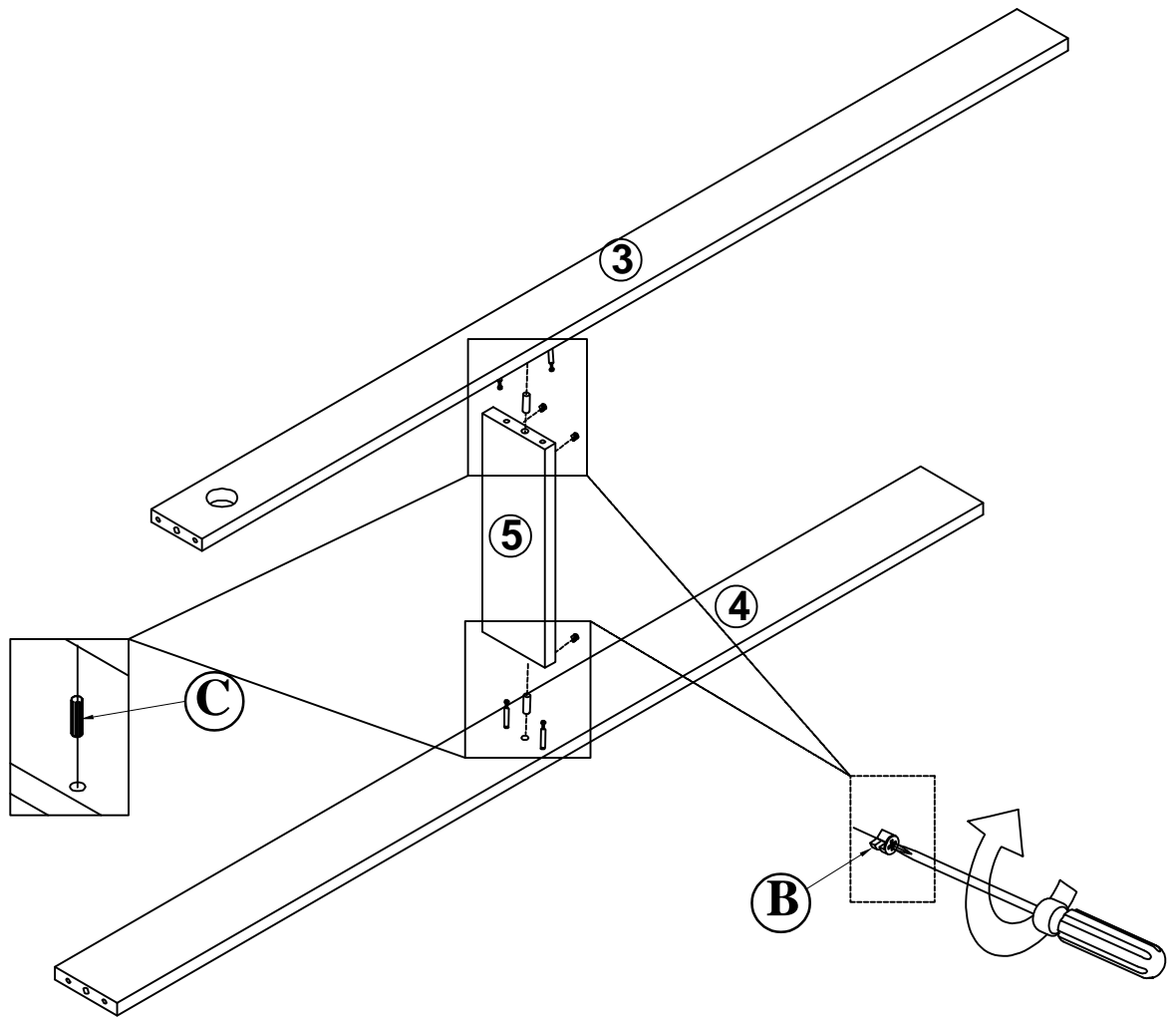
B		C	
	4pcs		2pcs



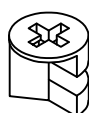

STEP 3: Following below illustration:

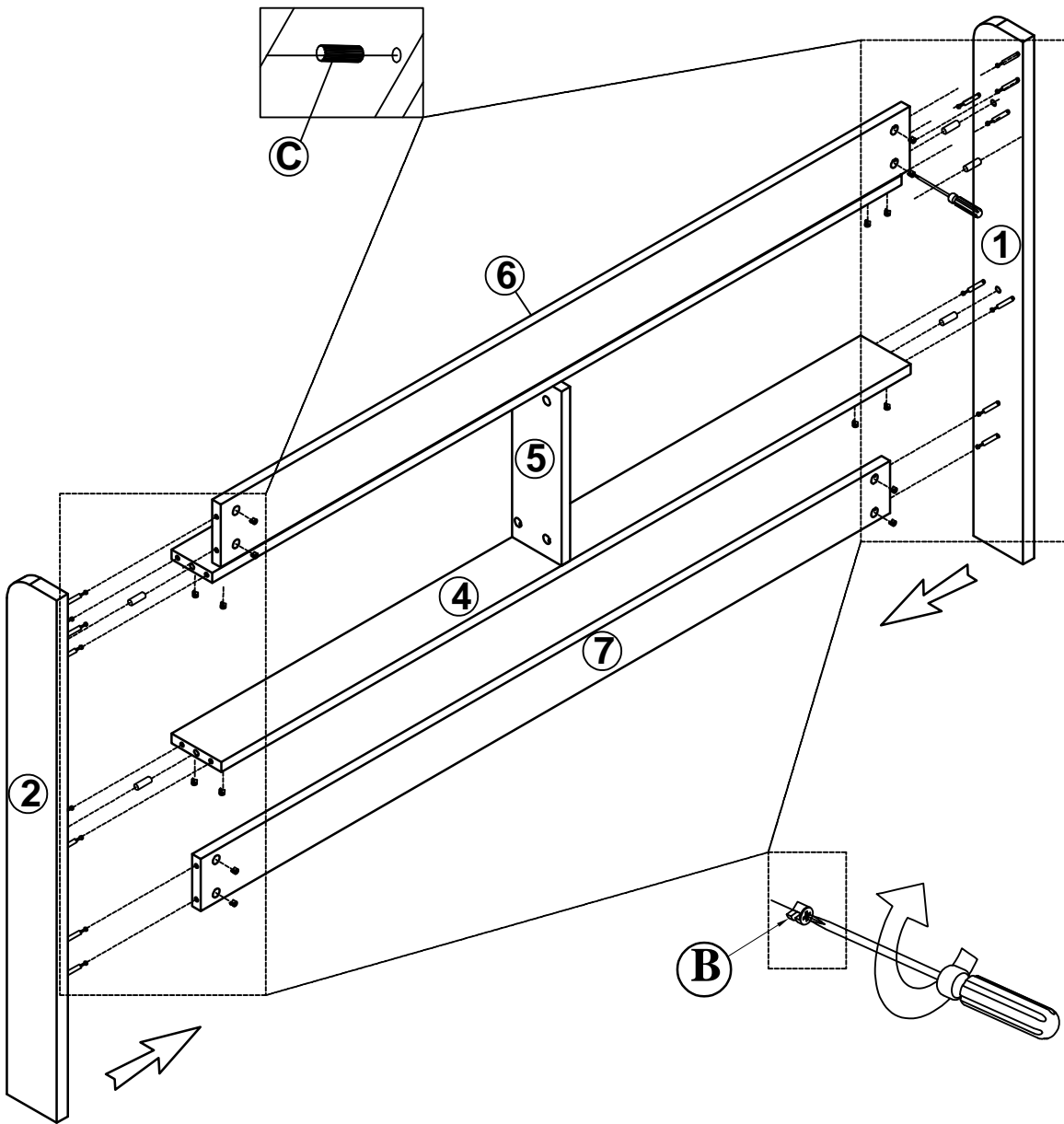
B		C	
	16pcs		4pcs



STEP 4: Following below illustration:

D 	C 
2pcs	4pcs

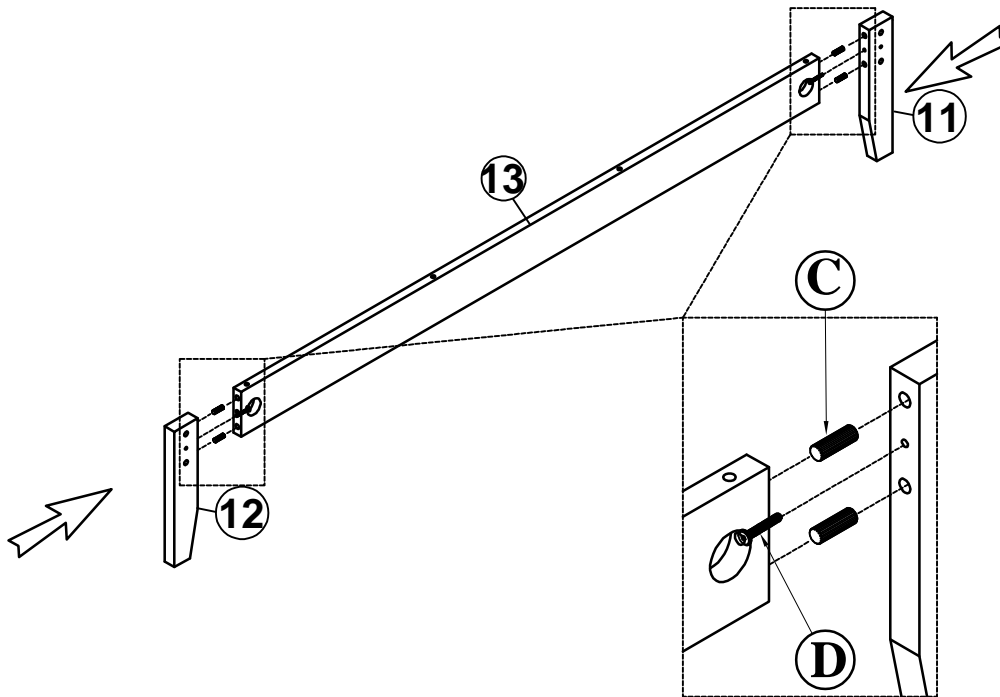

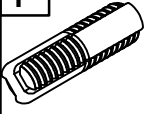

STEP 5: Following below illustration:

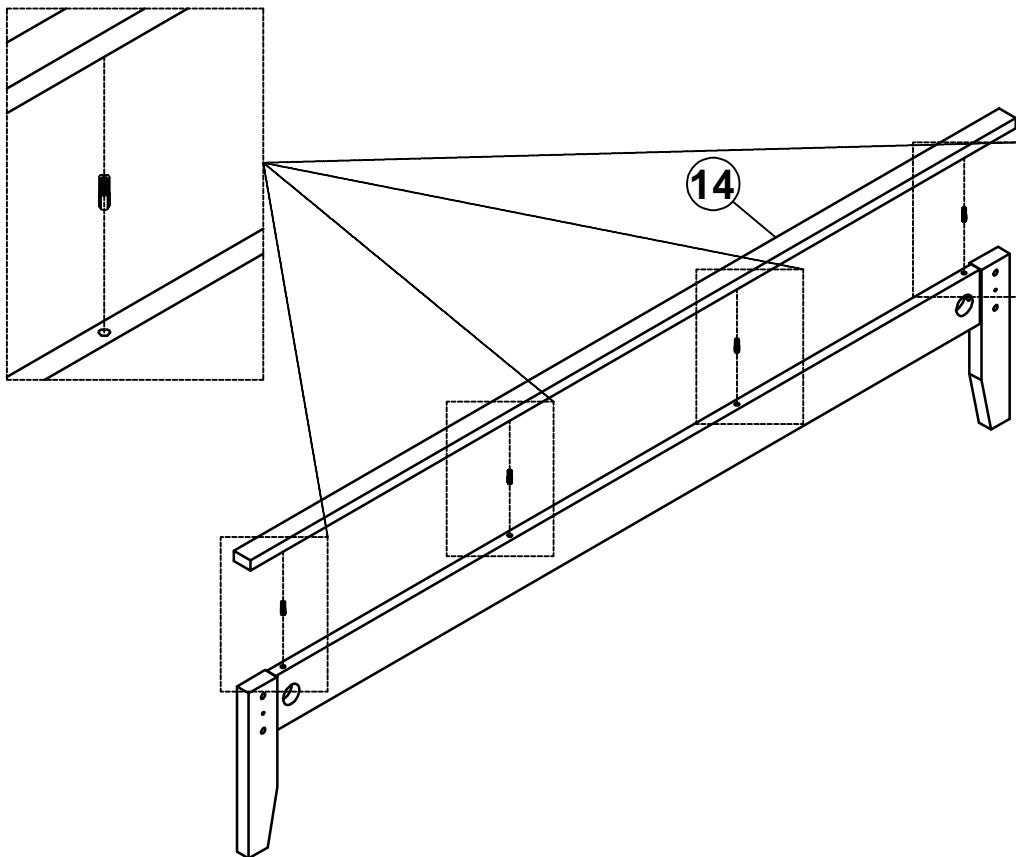
F 
4 pcs



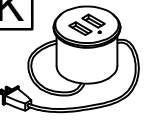

STEP 6: Following below illustration:

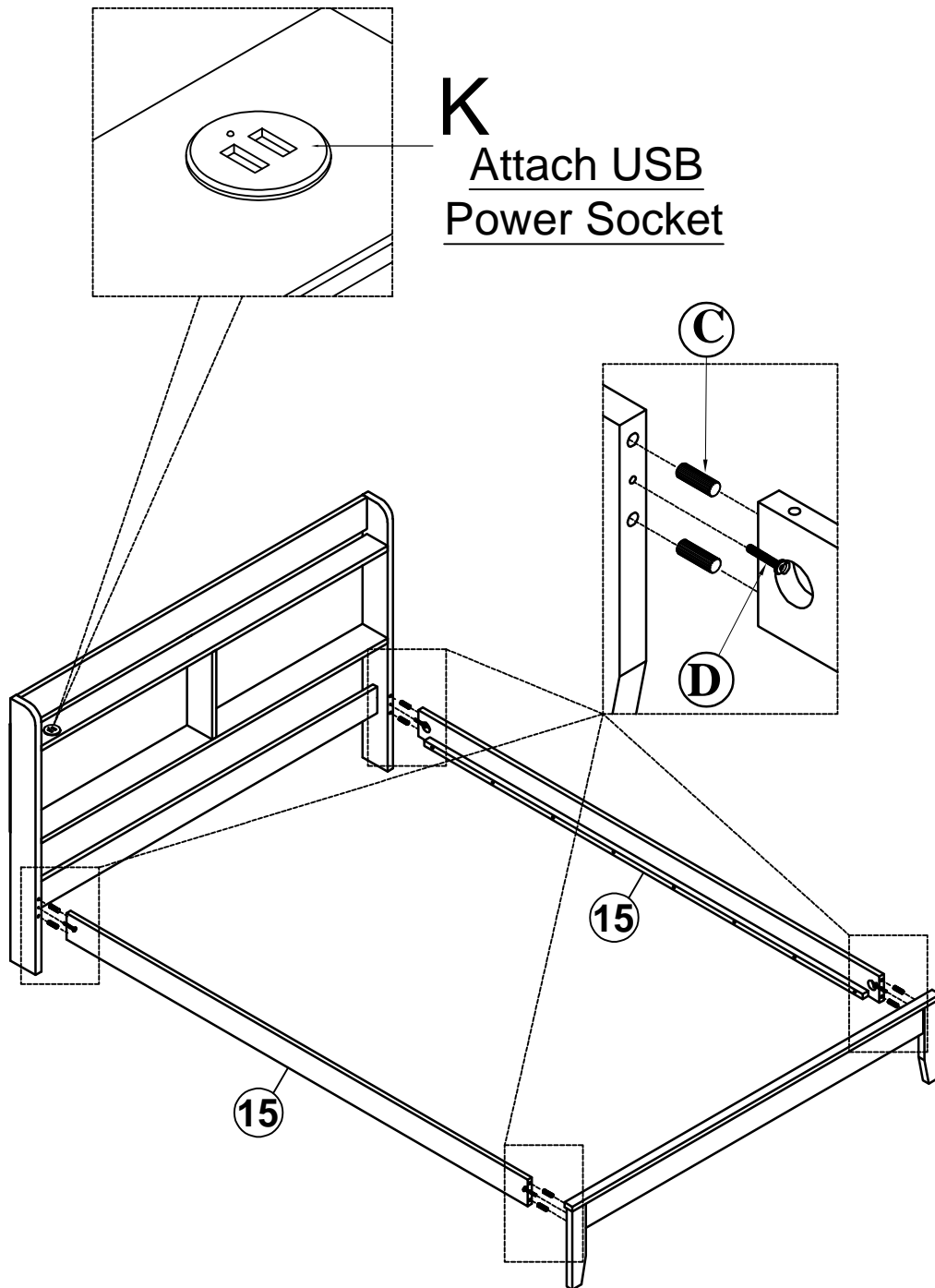
K 	D 	C 
1pcs	4pcs	8pcs

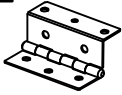

STEP 7: Following below illustration:

N 	M 
3pcs	15pcs

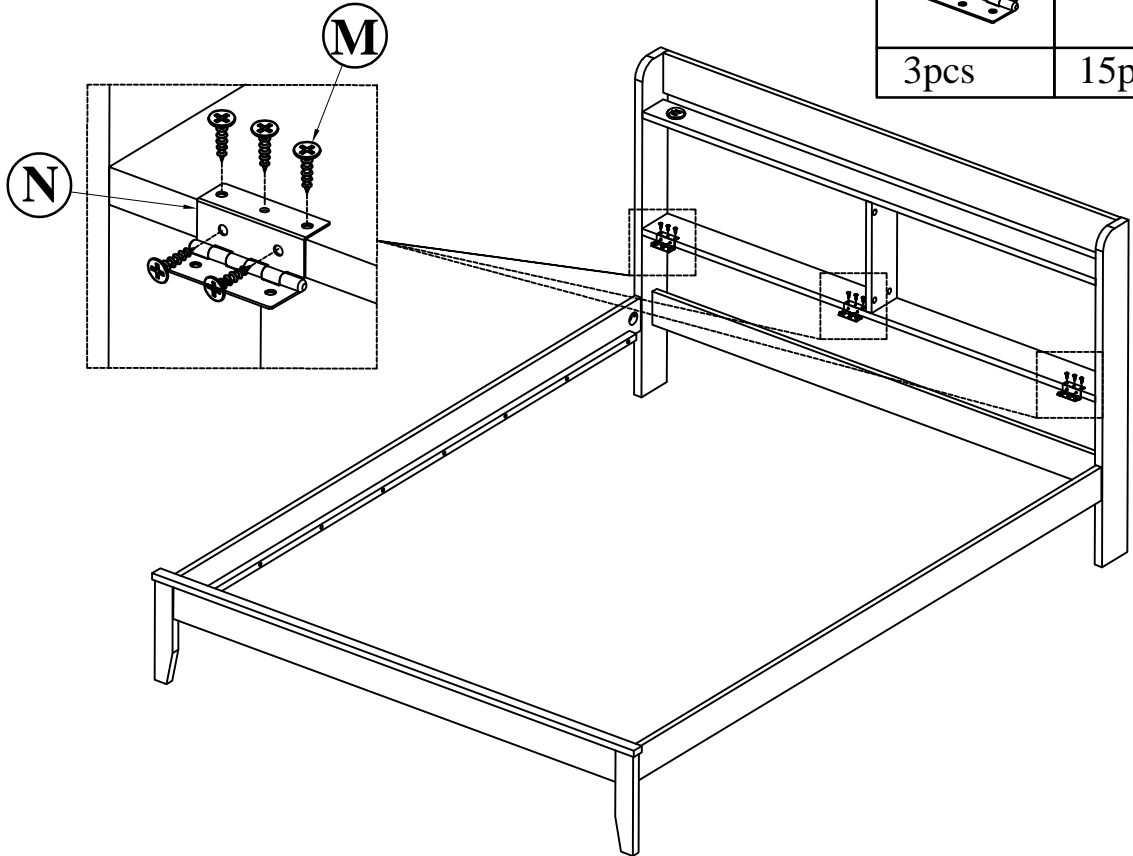

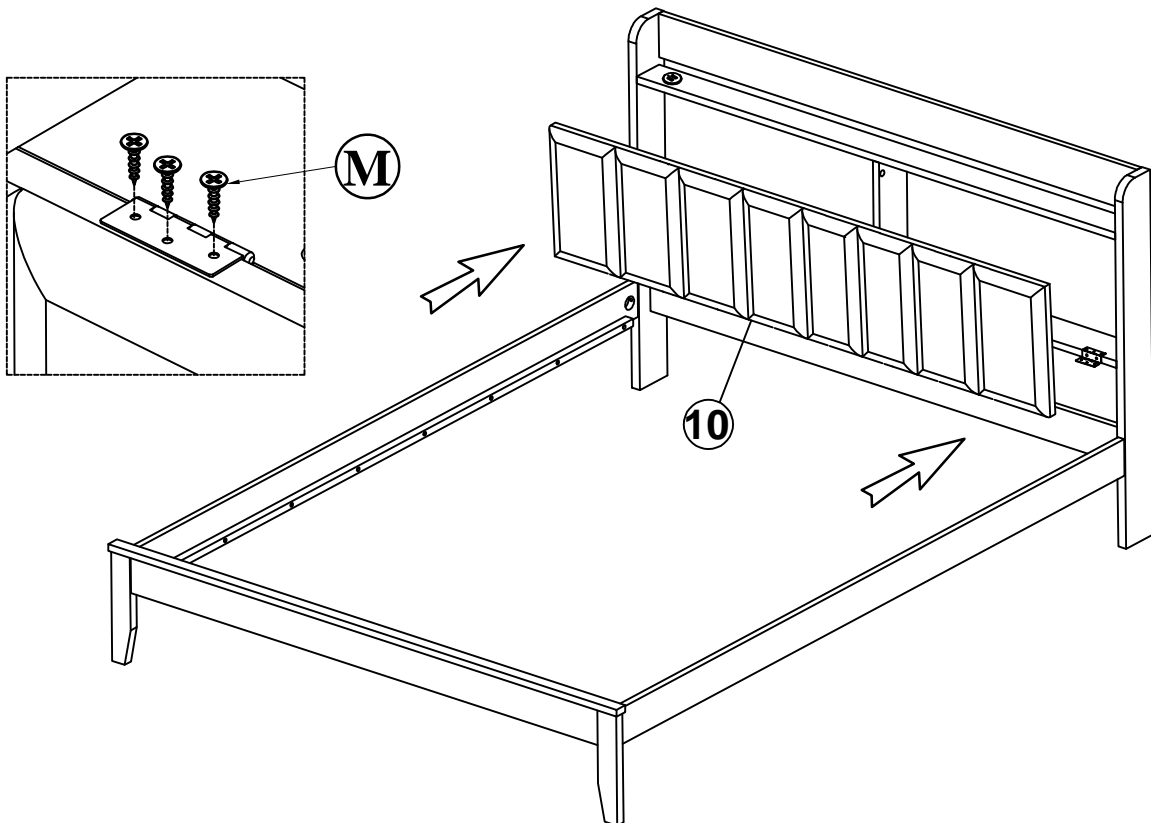

STEP 8: Following below illustration:

M 
9pcs



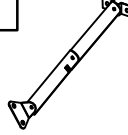

STEP 9: Following below illustration:

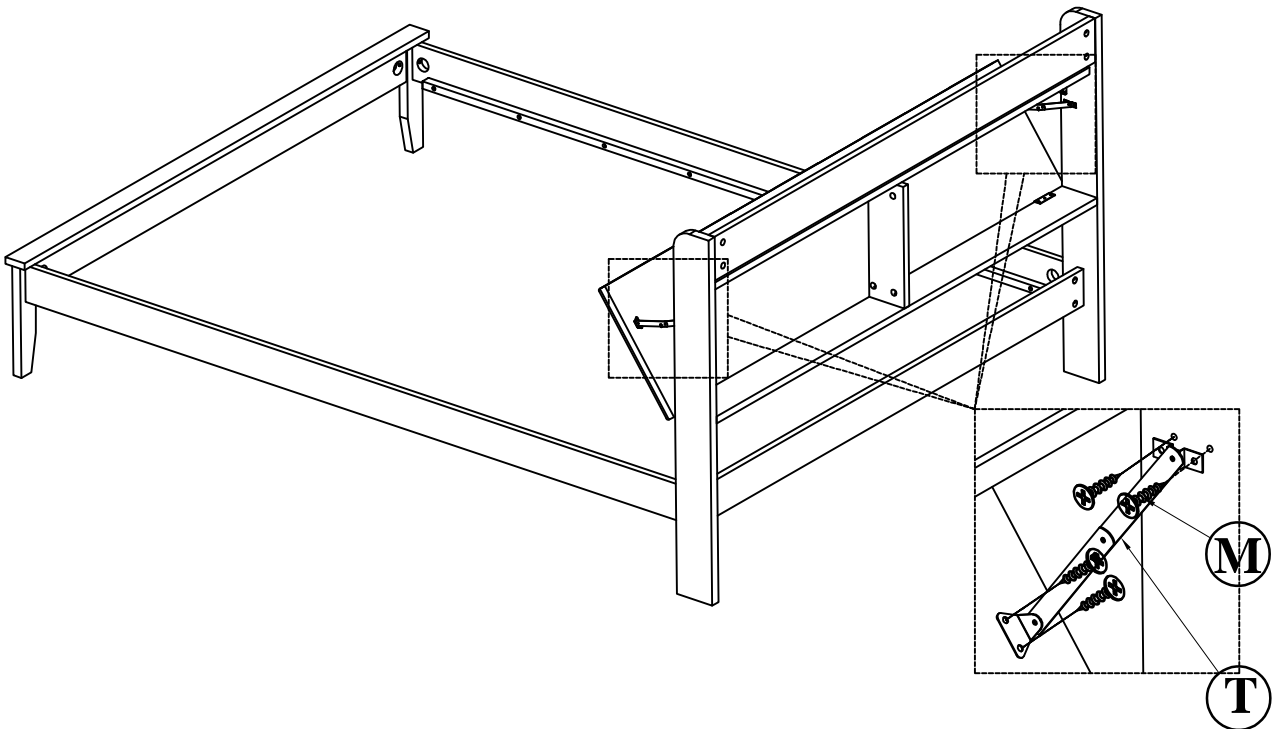
T 	M 
2pcs	8pcs



STEP 10: Following below illustration:

P 	M 
3pcs	12pcs

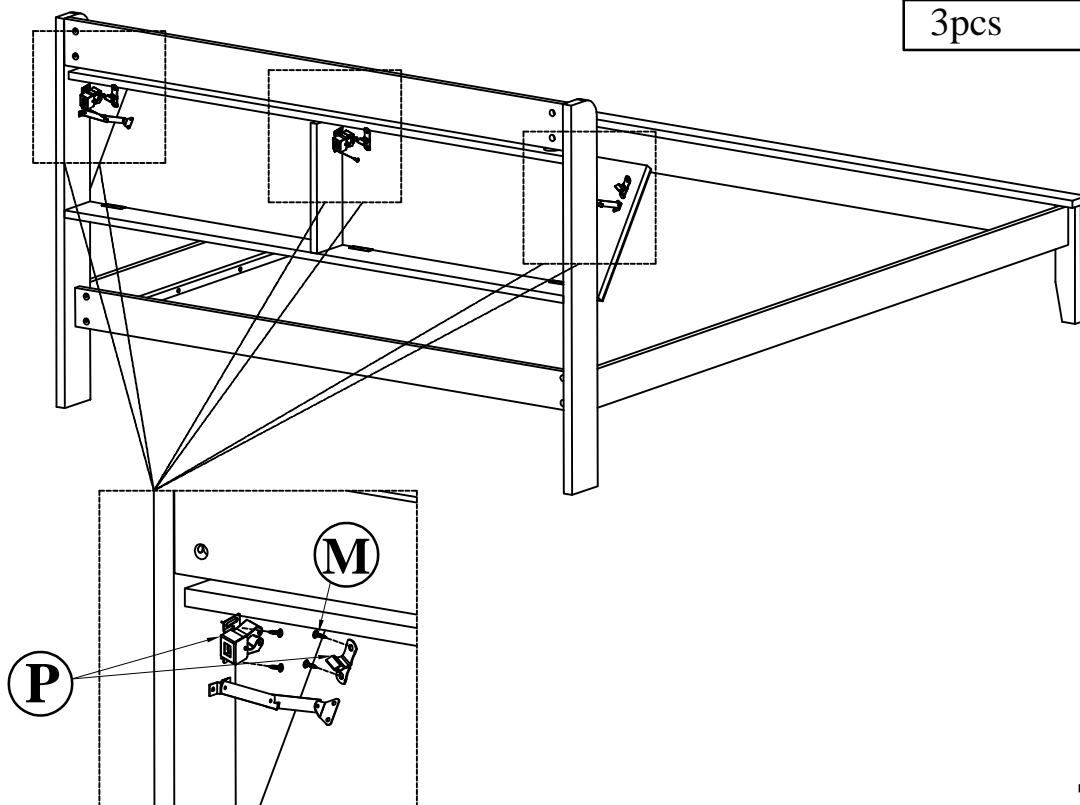

STEP 11: Following below illustration:

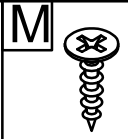

19pcs

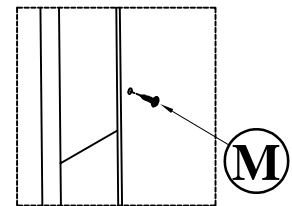
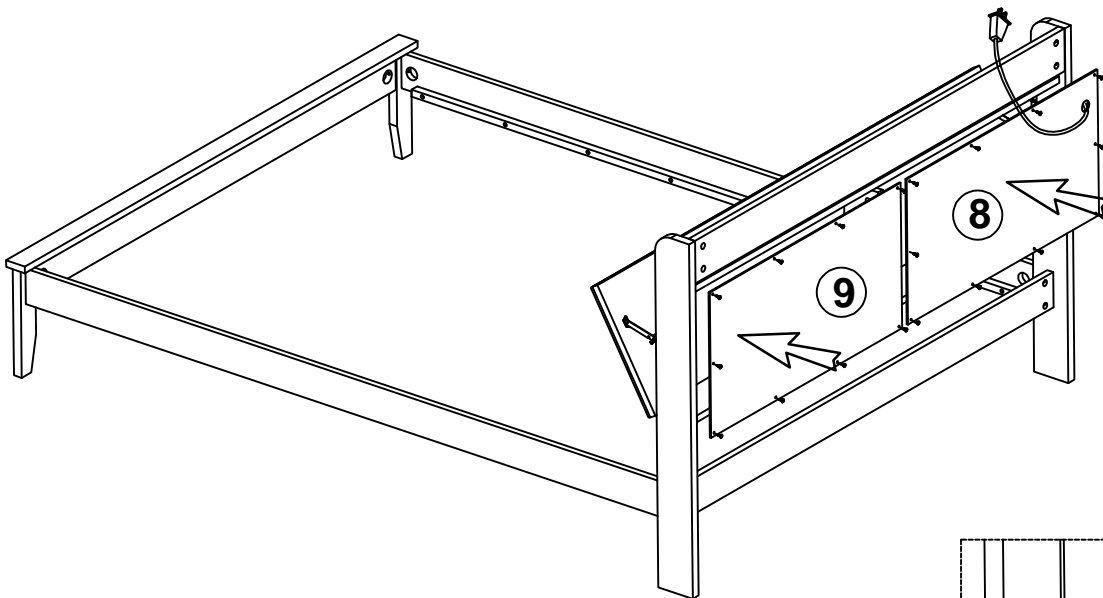

STEP 12: Following below illustration:

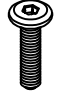
E		D	
	20pcs		3pcs

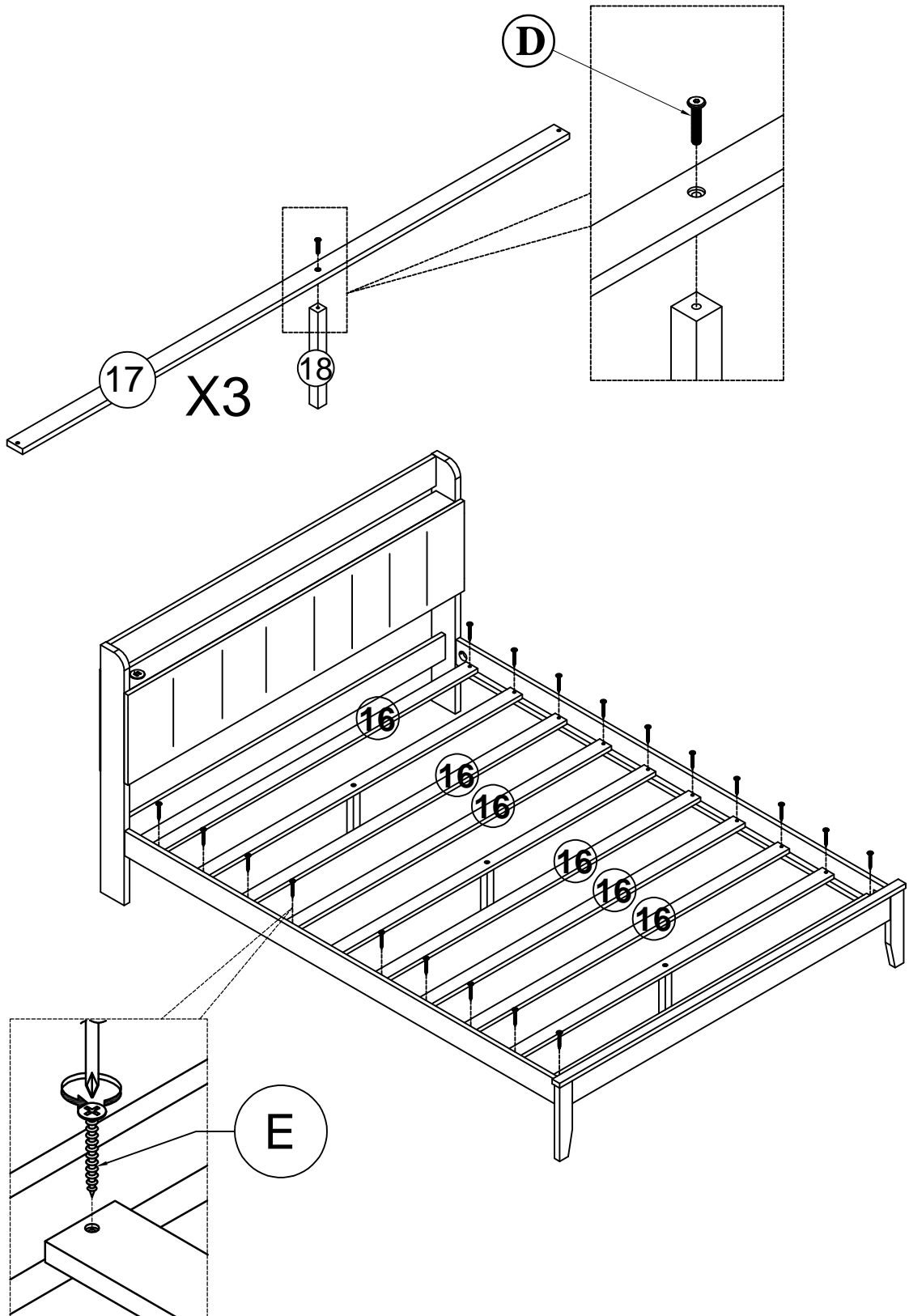

FINISH

