











Wooden Dining Chairs

Package:dining chair*2,tool kits*2,manual*1

USAGE PRECAUTIONS

The new chair may emit the smell of environmentally friendly paint, which is a normal phenomenon and harmless to health; please place it in a well ventilated area, the smell will dissipate naturally.

| | |
|---|--|
|  | Ensure that all screws and connectors are fastened during installation, and check the looseness regularly. |
|  | Confirm the maximum load capacity of the dining table and chairs before use to avoid overweight leading to structural deformation or damage. |
|  | Dining chairs need to be placed smoothly, the ground is not flat can be adjusted foot pads or the use of non-slip pads. |
|  | Don't tilt the back of the chair too much or hang heavy objects to prevent tipping. |
|  | Pay attention to the obstacles on the ground when the dining chair is moving to avoid impact. |
|  | Children need adult care when using, to avoid accidental falls or collision, sharp corners can be added to the crash bar, to reduce the bump injury. |
|  | Prohibit children under 6 years old from contacting the screw nut toolkit to prevent swallowing. |
|  | Regularly wipe the surface with a soft cloth to remove dust, stubborn stains can be diluted with a neutral detergent and gently wipe, avoid the use of acidic, alkaline or corrosive detergents. |
|  | Use wood wax oil once every six months to maintain the luster. |
|  | Keep away from high-temperature sources (such as heating, open fire) and direct sunlight to prevent wood furniture from cracking or discoloration of paint. |

INSTALLATION STEPS

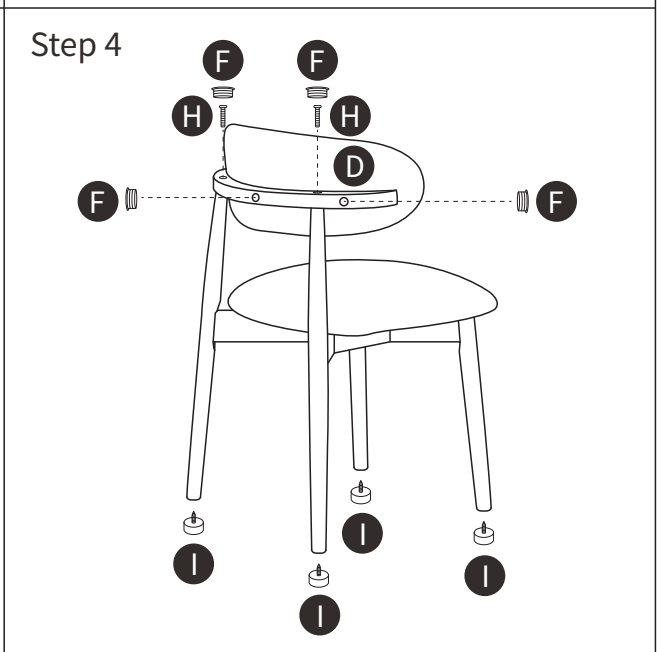
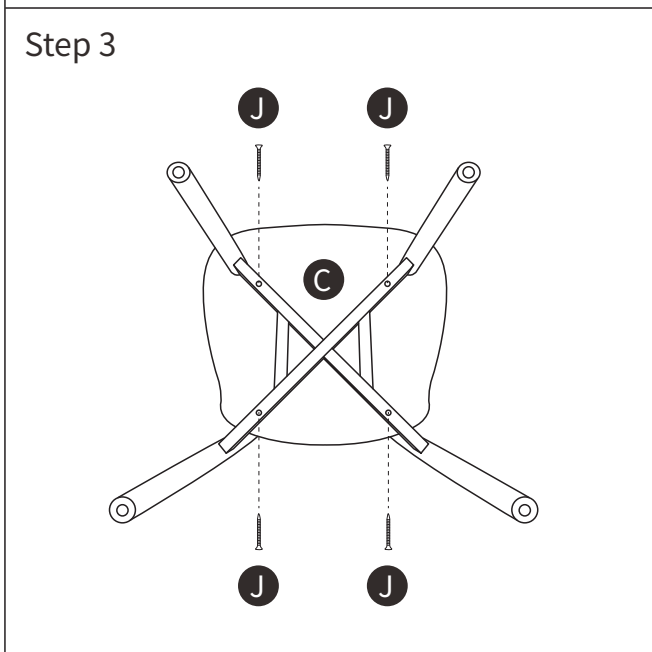
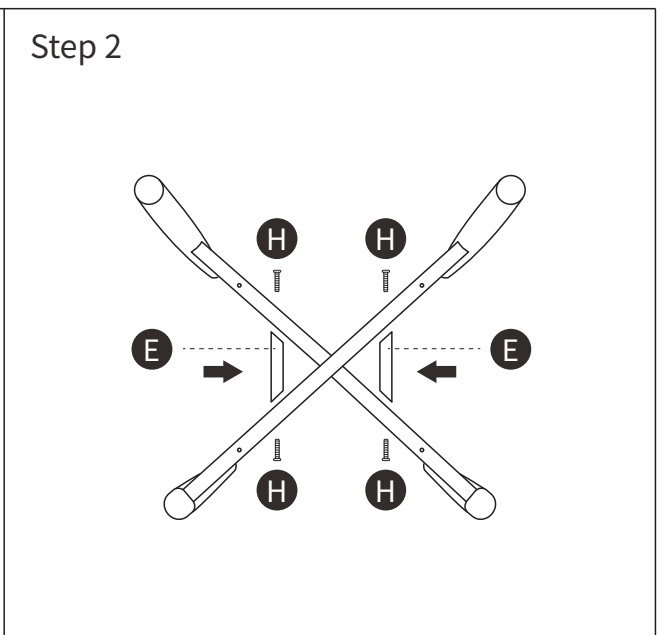
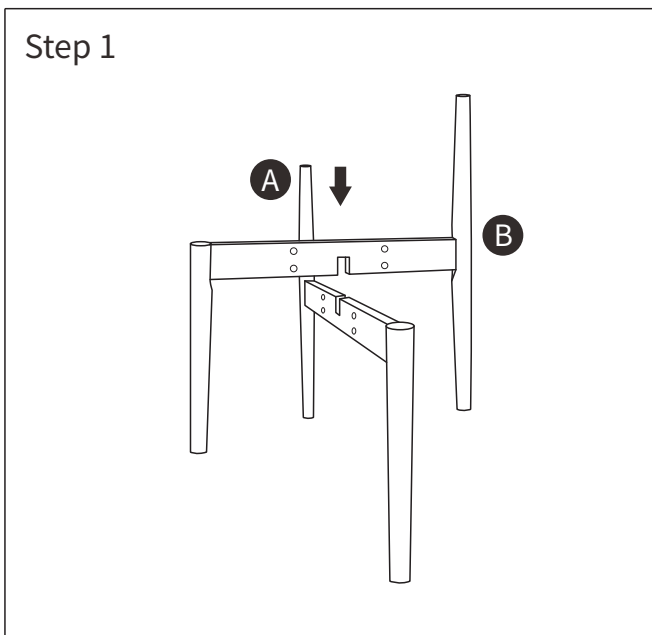
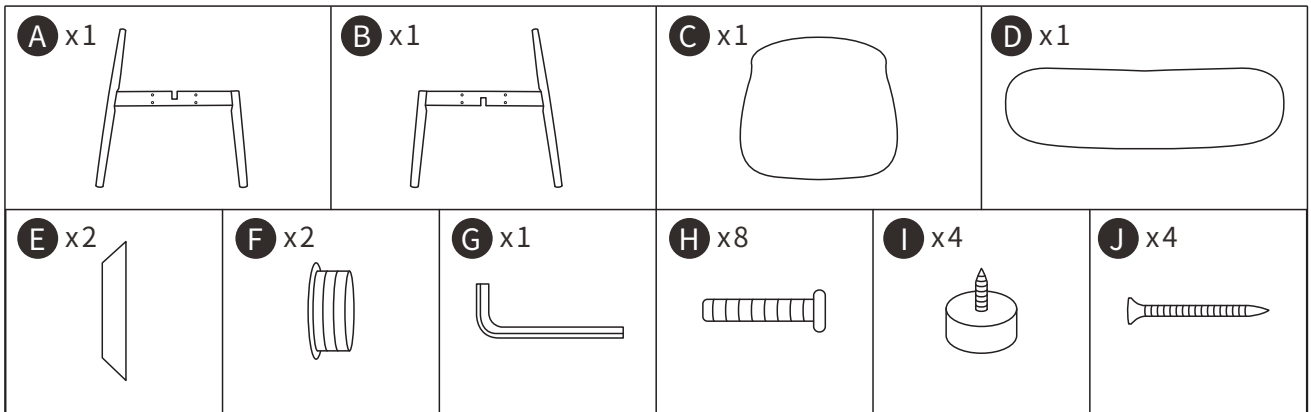

FAQ

- **What if the screws are loose?**

Tighten with the appropriate tools and add thread adhesive if necessary.

- **What about structural rattling?**

Check whether the connection is deformed, contact after-sales service.

- **What about scratches on the surface?**

Minor scratches can be repaired with touch-up cream, but serious scratches require professional treatment.



Please keep this manual and proof of purchase to enjoy the after-sales service!