

FULL BED

ASSEMBLY INSTRUCTIONS

Read this instruction carefully. See hardware and furniture part list for guidance. Be sure all parts are complete, before you assemble. Place all wooden furniture parts on a clean and flat soft surface to prevent from being scratched. Follow the figure to start assembling.

CAUTIONS : 1. Do not FULLY - TIGHTEN the nut or nut bolt until all nut or bolt is ready assembled.
2. Do not OVER - TIGHTEN the nut or bolt to avoid causing damages to the thread.
3. Keep all hardware parts out of reach of children.

NOTE : THE LIST AND QUANTITY SHOWN ARE FOR 1 UNIT ASSEMBLY.
Tool needed : Screwdriver (not provider).

PART LIST		
ITEM	DESCRIPTION	QTY
A	HEADBOARD	1 PC
B	FOOTBOARD	1 PC
C	SIDE RAIL	2 PCS
D	CENTER RAIL	1 PC
E	CENTER SUPPORT	2 PCS
F	CENTER SUPPORT LEG	3 PCS
G	BED SLAT	24 PCS
H	BED LEG	4 PCS

HARDWARE LIST		
ITEM	DESCRIPTION	QTY
1	JCBC BOLT M6 x 20mm	8 PCS
2	JCBB BOLT M8 x 30mm	8 PCS
3	M6 FLAT WASHER	8 PCS
4	M6 SPRING WASHER	8 PCS
5	WOOD SCREW M3.5 x 16mm	8 PCS
6	WOOD SCREW M4 x 25mm	8 PCS
7	BED SLAT SIDE FITTER	24 PCS
8	BED SLAT CENTER FITTER	12 PCS
9	M4 ALLEN KEY (BALL SHAPE)	1 PC
10	M5 ALLEN KEY (BALL SHAPE)	1 PC

STEP 1

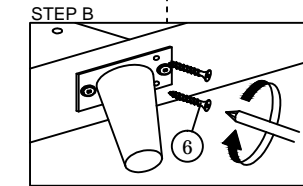
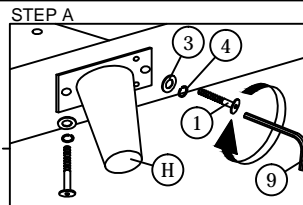
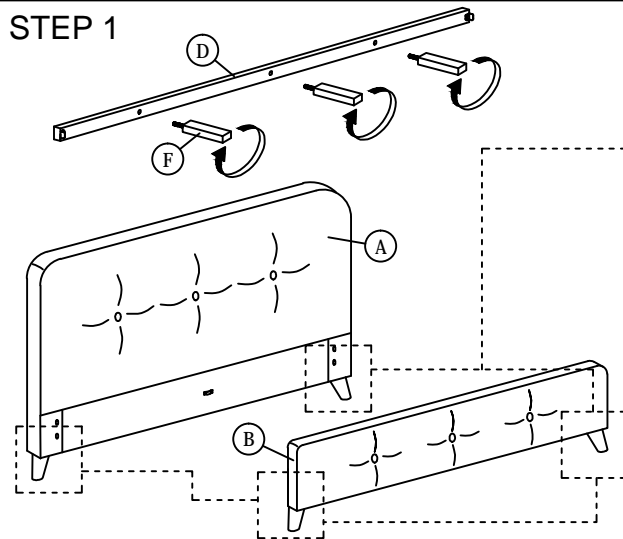

STEP 2

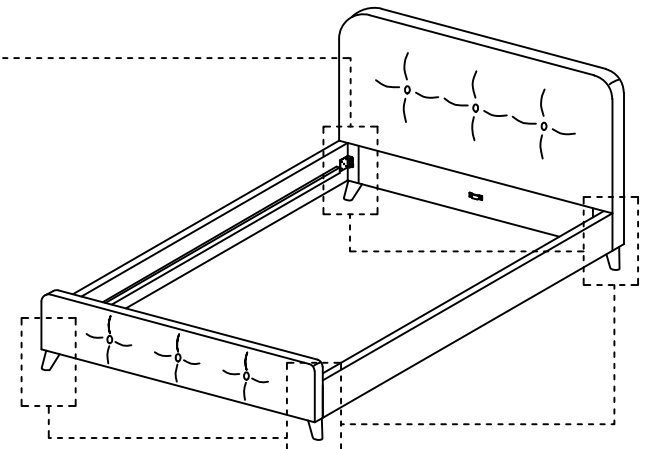
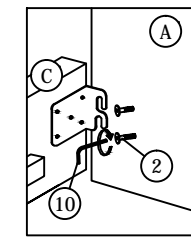

STEP 3

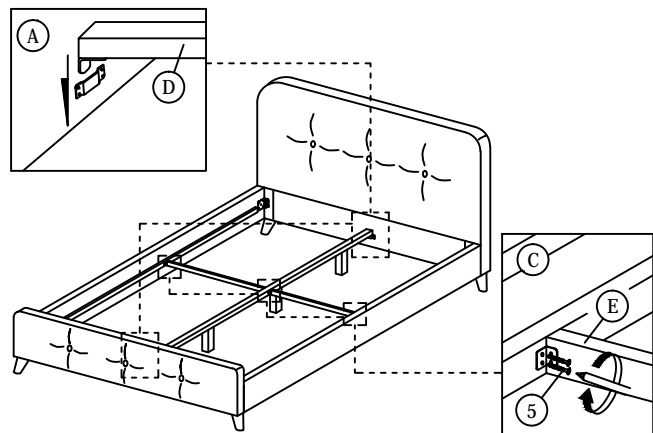

STEP 4

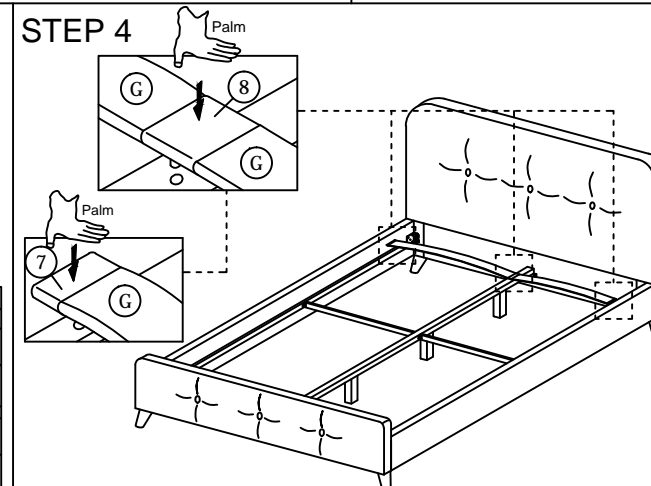

STEP 5

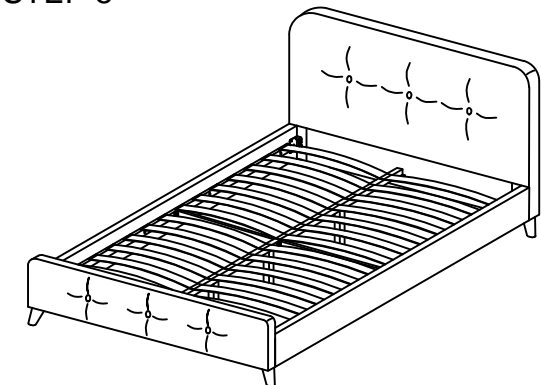

* When moving the bed position, the center support legs must be adjust to be straight to avoid any broken problem.