

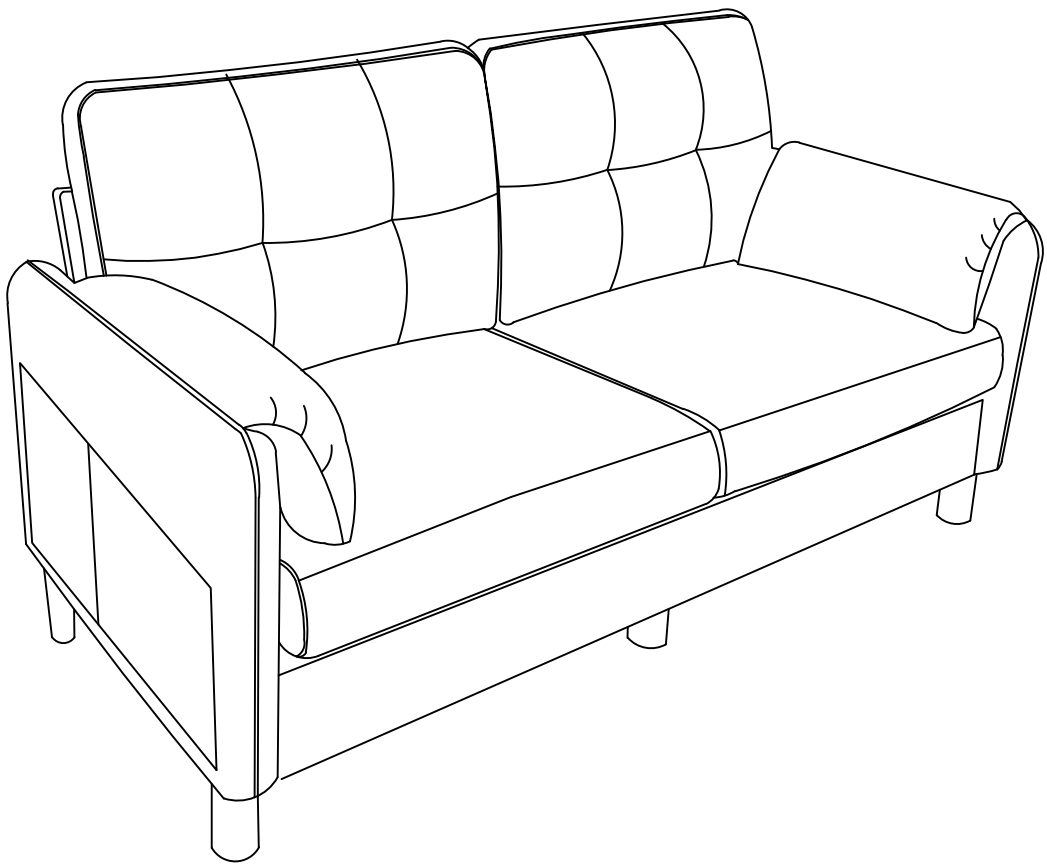

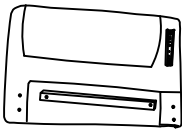

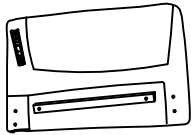

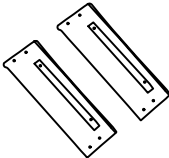

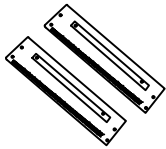
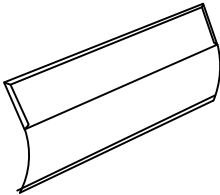
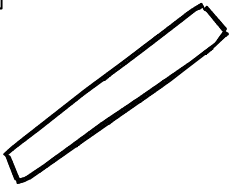
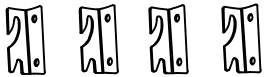

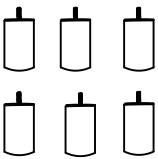
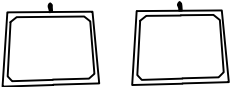
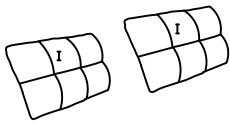
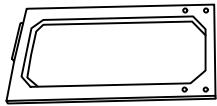

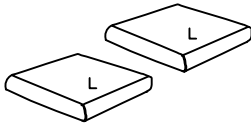
LOVE SEAT COUCH

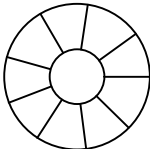
Assemble Instructions



PART LIST

AL 	AR 	B 	C 
Left armrest(1PC)	Right armrest(1PC)	Front plate(2PCS)	Back plate(2PCS)
D 	E 	F1 	F2 
Back rest(1PC)	Cover (1PC)	Accessories(4PCS)	Accessories(4PCS)
G 	H 	I 	JL 
Foot(6PCS)	Frame(2PCS)	Back cushion(2PCS)	Backrest(1PC)
JR 	L 	M 	N 
Backrest(1PC)	Seat Cushion(2PCS)	Allen KeyM6(1PC)	Gasket (32PCS)
O 	P 	Q 	R 
Plastic Gaskets(4PCS)	Screw M6*20 (32PCS)	Screw M6*30(8PCS)	Screw M8*90(2PCS)
S 	T 	U 	Note: The screws are in 1:1 ratio and can be placed here for comparison.
Angle iron(2PCS)	Mid-Range(1PC)	Wing nut(2PCS)	

DISASSEMBLY DIAGRAM

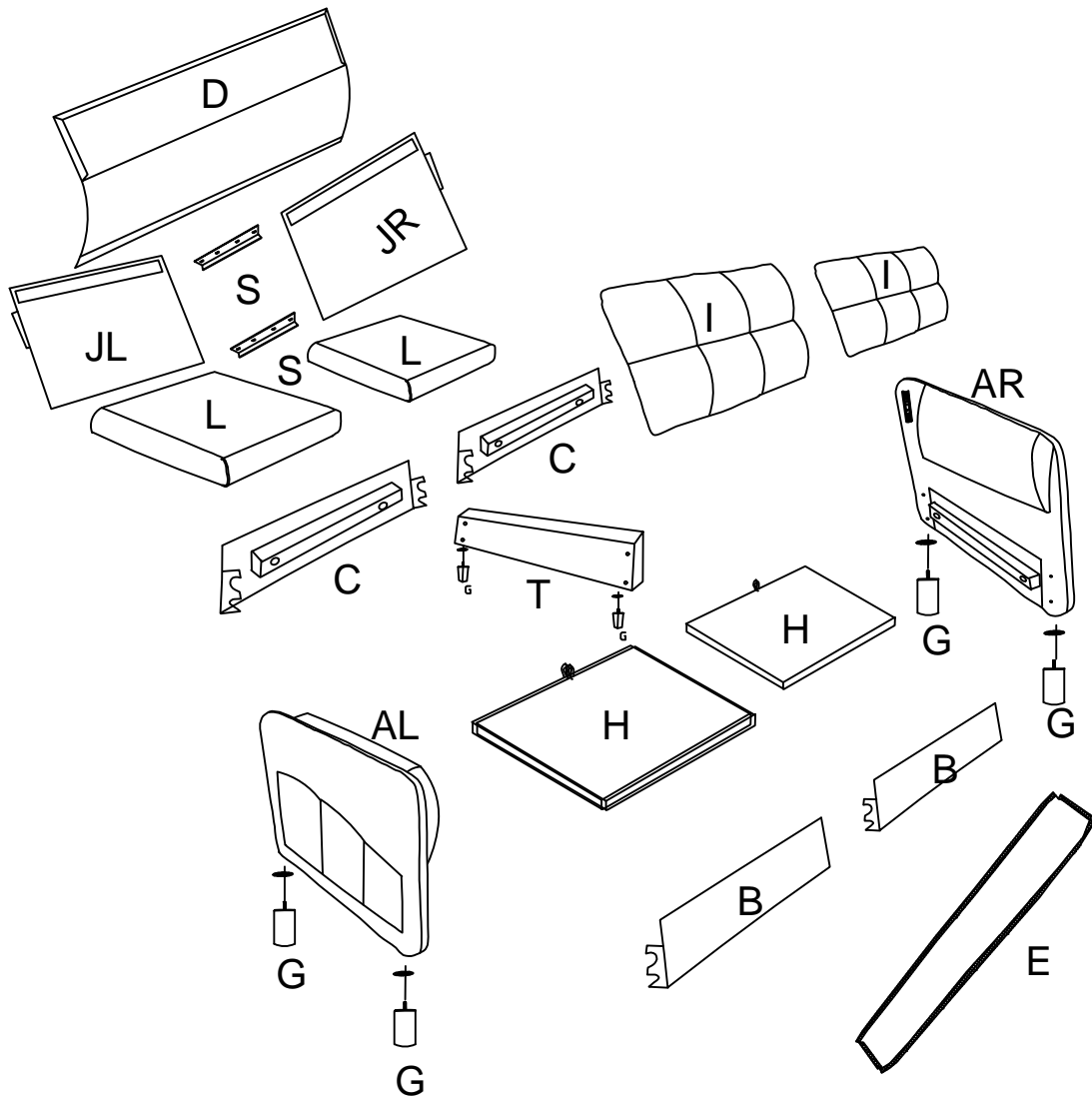



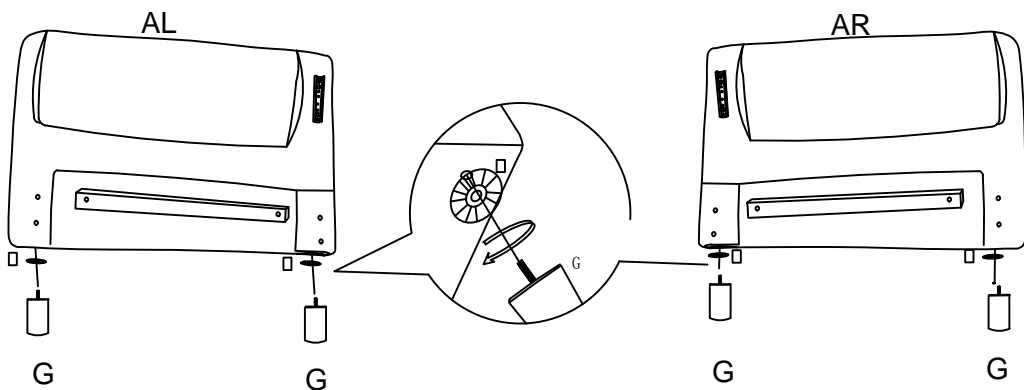

STEP1

Screw the sofa feet G with plastic spacers O into the sofa arms(AL/AR).

AL		1
AR		1
G		4
O		4







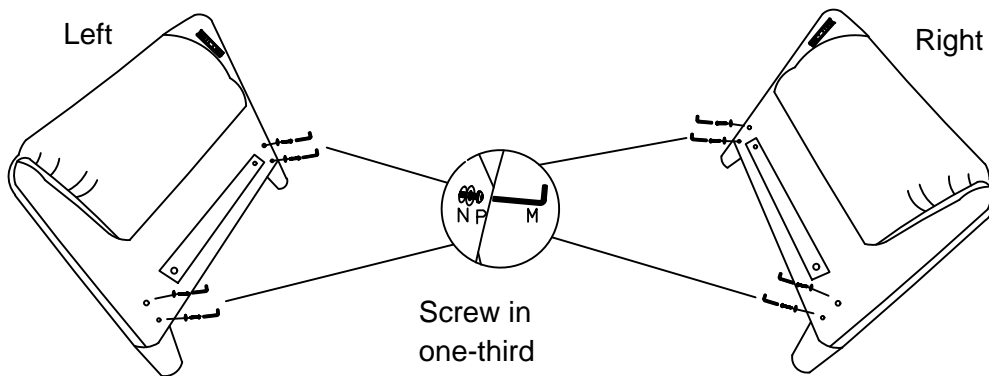

STEP2

AL		1
AR		1
P		8
N		8
M		1

Screw the screws P and spacers N into the armrests of the sofa with a Allen Key one third of the way in.





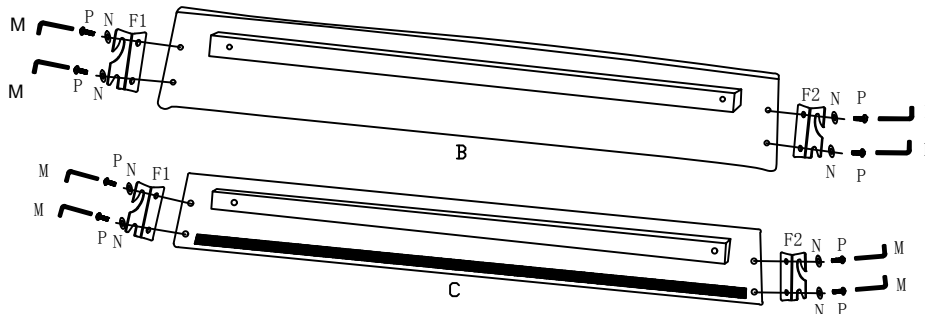

STEP3

F1		4
F2		4
B		2
C		2
P		16
N		16
M		1

As shown in the figure, first align the connecting iron piece F1/F2 with the holes plate B/plate C. Tighten the spacer N and screw P with a Allen Key. One third of the way in.



STEP4

T		1
P		8
N		8
M		1

First align the rod T with the holes in the armrests then screw the screws P and spacers N into the armrests of the sofa using a Allen Key. One third of the way in.

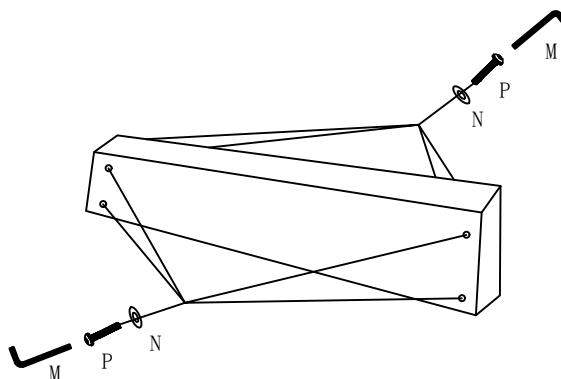

STEP5

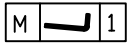

As shown in the figure, the front seat frame plate B and the rear seat frame plate C are respectively hung on both sides of the middle seat gear T. Then use an Allen wrench to tighten the screws on both sides.

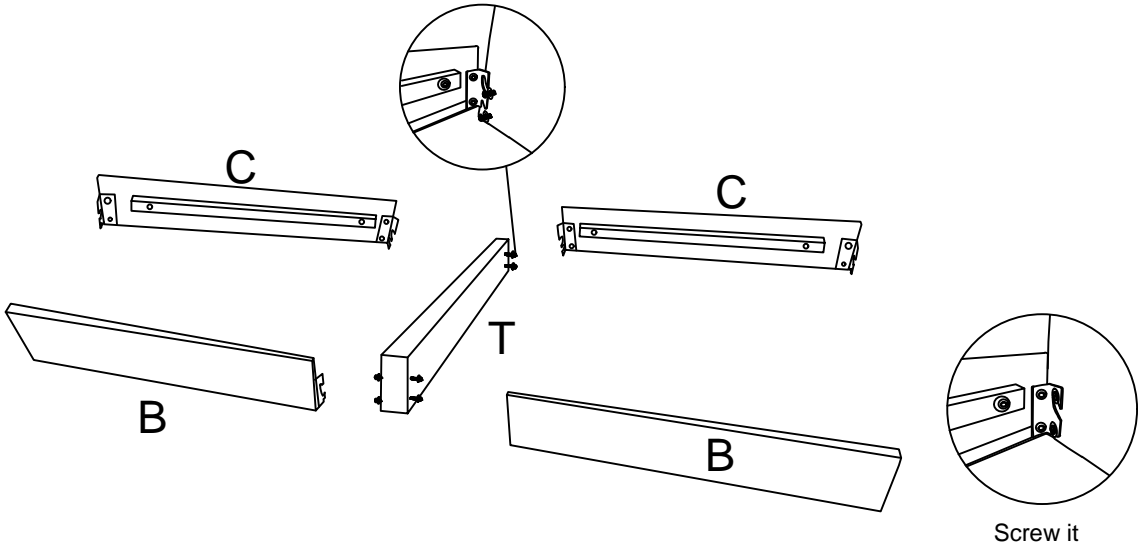

STEP6



As shown in the picture, place the E-felt on the front side of the seat frame. Be sure to stick the front opening flat before this step.

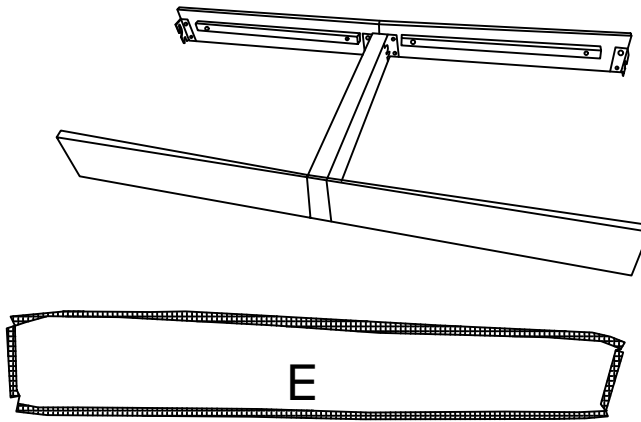

STEP7

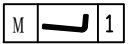

As shown in the figure, hang the pasted and assembled seat frames on the front and rear sides of the armrests AL and AR respectively, and tighten the screws on both sides with hexagonal screws.

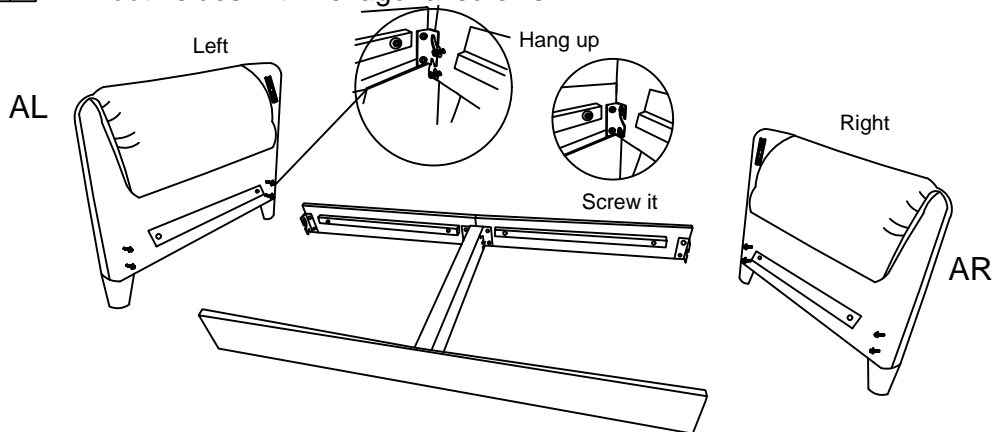

STEP8

As shown in the figure, the back frame JL and back frame JR are connected in series with screw R, and the other side is fixed and tightened with butterfly nut U. Pay attention to the up and down position of the backrest when connecting in series. When assembling the backrest frame, the arrow indicators on both sides should face the upper opening.

JL		1
JR		1
R		2
N		4
U		2
M		1

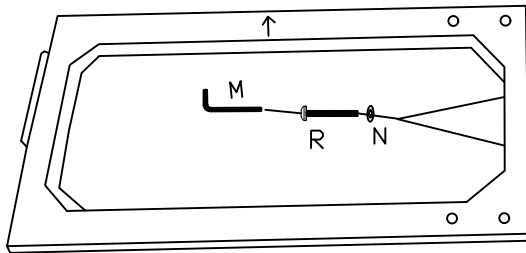

JL

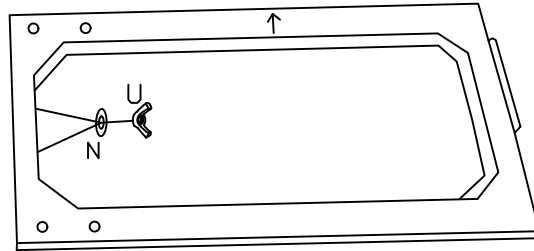

JR

STEP9

As shown in the figure, fix the assembled back frame with angle iron S and secure it with screw Q. Use an Allen wrench M to tighten the upper and lower screws. Be sure to assemble the iron angle on the back side of the backrest frame when assembling.

Q		8
S		2
M		1

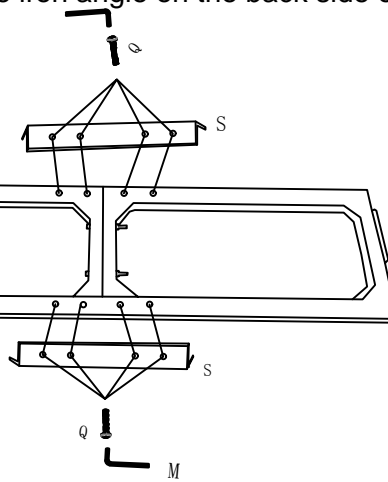

STEP10

As shown in the figure, place the back frame sleeve D onto the assembled back frame. The bottom and sides should be firmly adhered.

D		1
---	--	---

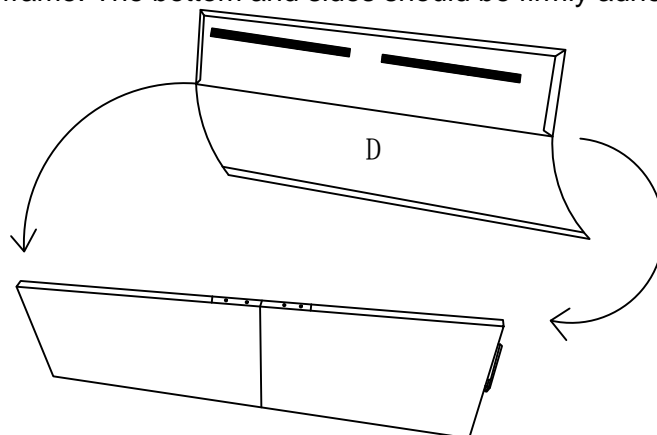

STEP11

G	0	2
0	0	2

As shown in the figure, the front and rear mounting feet of the middle gear are equipped with G and plastic gaskets.

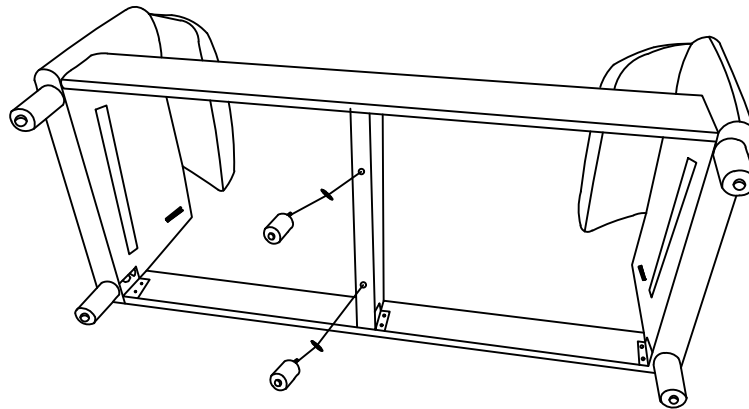

STEP12

As shown in the figure, connect the assembled back frame and seat frame from top to bottom with the plug-in inserted into the back of the armrest. Note that when connecting plugins, both sides should be inserted horizontally downwards.

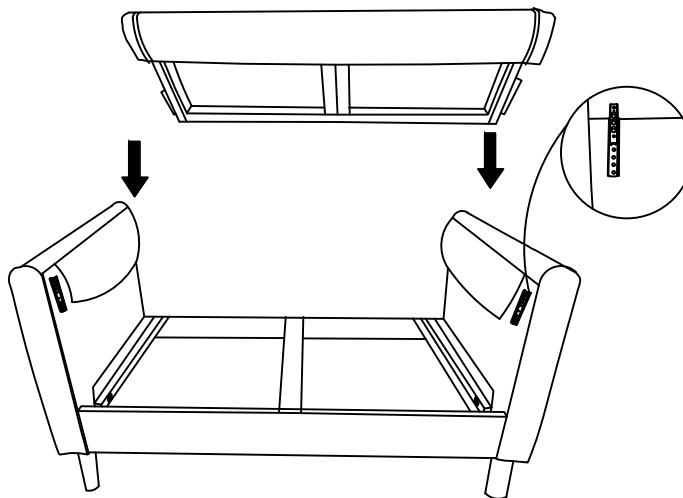

STEP13

I	L	2
L	L	2

Use the cutting tool to open the compression bag and remove the back cushion I, and seat cushion L. Adjust to the original shape by hand.

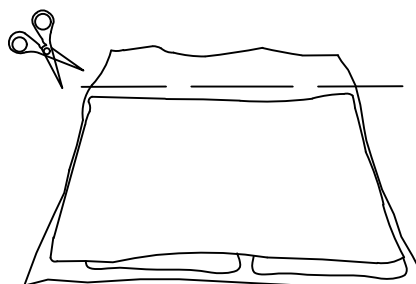

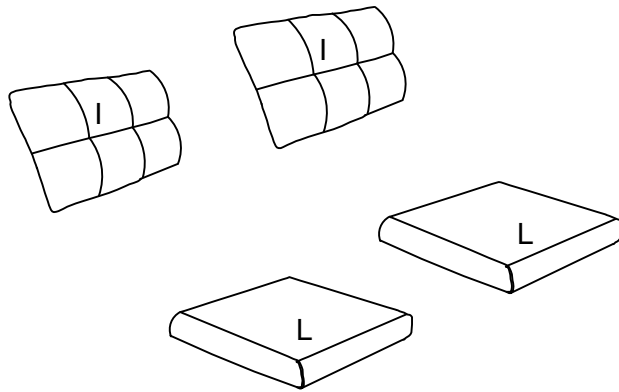

STEP14

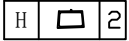

Put on the seat frame H.

The handle should be placed inward.

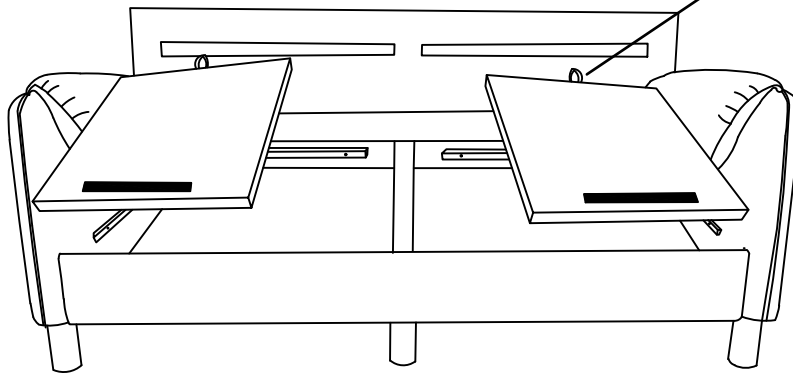

STEP15



Place the seat/back cushion on the sofa as shown in the picture and secure it firmly to the sofa body using the velcro fasteners on the base/back cushion. If the fabric has wrinkles, please wait for 72 hours for the cushions to fully rebound.

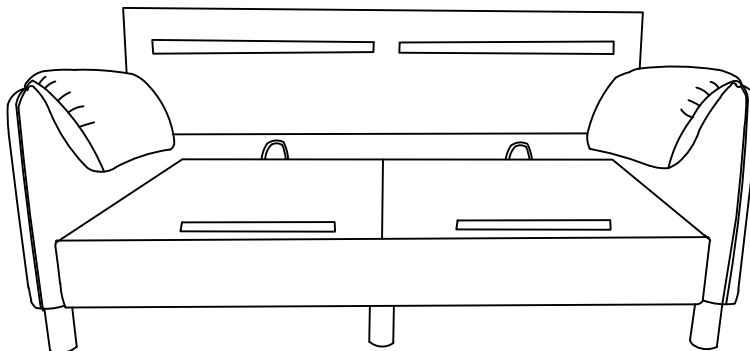

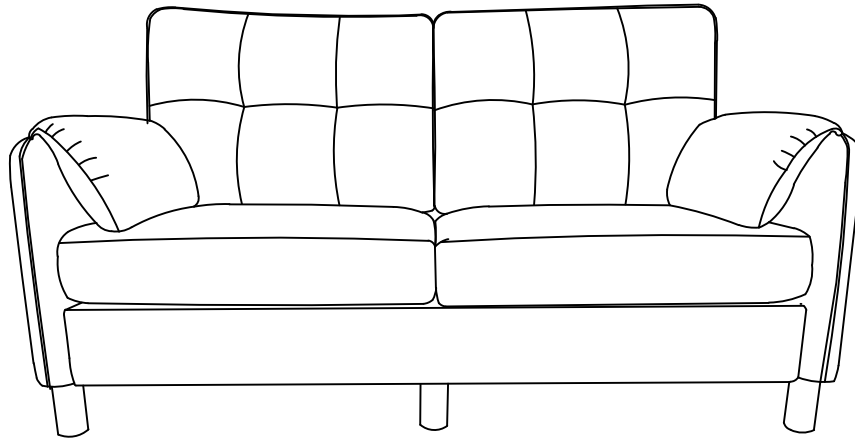
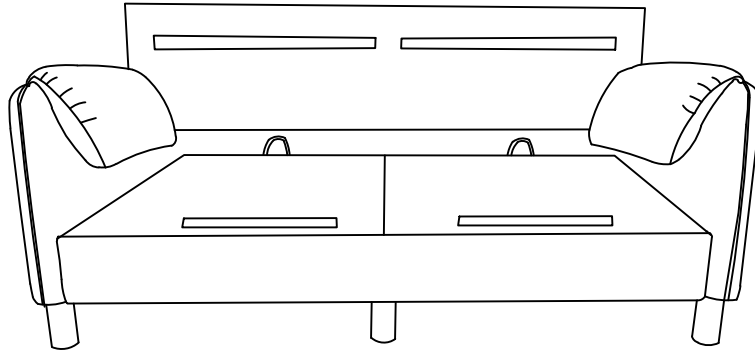

FAQ

Q1:Missing parts or some parts damaged when received.

A1:If you find some parts are missing or damaged from the box,please kindly send us messages to let us know the name of missing part regarding of the parts list of the instruction,we will send you the replacement and offer you the best solution asap.

Q2: Assemble Difficultly

A2:If there are any problems during the installation process, you can take photos and send them to us, and we will reply promptly. There are also installation videos on our page that you can view online.

Q3 :Return Policy.

A3: Before returning the item, please contact us about return issue,please make sure that the box packaging is complete,the product is not damaged, stained and not affecting secondary sales. Return product that do not use the original packaging may be rejected, and the pictures may be requested to offer.