

ASSEMBLY INSTRUCTIONS

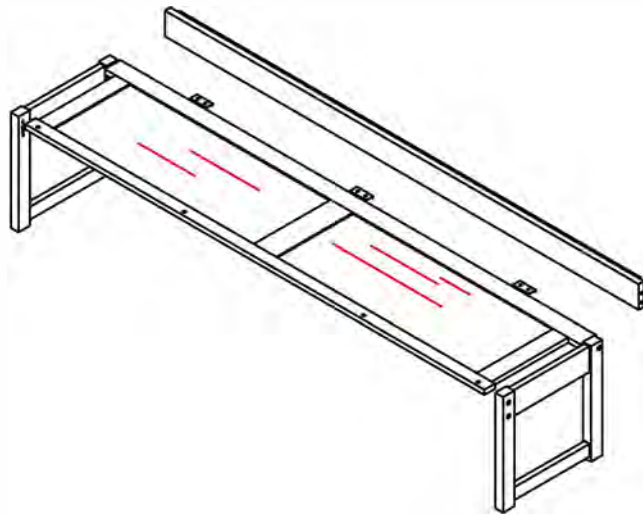

Extension Kit

ASSEMBLY INSTRUCTIONS

ASSEMBLY TIPS :

1. Remove hardware from box and sort by size.
2. Please check to see that all hardware and parts are present prior to start of assembly.
3. Please follow attached instructions in the same sequence as numbered to assure fast & easy assembly



WARNING! :





1. Don't attempt to repair or modify parts that are broken or defective. Please contact the store immediately.
2. This product is for home use only and not intended for commercial establishments.





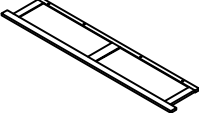

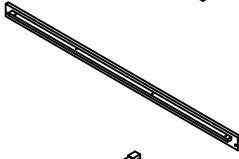
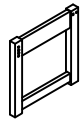

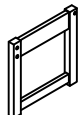
ASSEMBLY TIME

15 MINUTES

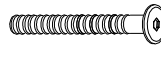
PARTS IDENTIFICATION

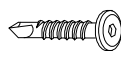
A	TOP PANEL		1PC	TT	(B1&B2)		1SET
B	CENTER RAIL		1PC		OR		
C	LEFT PANEL		1PC	TT	(B1&B2)		1SET
D	RIGHT PANEL		1PC				

HARDWARE IDENTIFICATION

1	LONG BOLT (M6 x 80mm - BLK)		8PCS	5	BARREL NUT (M6 x 13mm - RBW)		8PCS
2	SHORT BOLT (M6 x 30mm - BLK)		4PCS	6	METAL BRACKET (BLK)		3PCS
3	FLAT HEAD SCREW (M3.5 x 16mm - BLK)		12PCS	7	ALLEN WRENCH (M4 - BLK)		1PC
4	WOOD DOWEL (Ø10 x 30mm)		8PCS				

NOTE:

Philips head screw driver is required in the assembly process; however, manufacturer does not provide this item.

ASSEMBLY INSTRUCTIONS

STEP 1

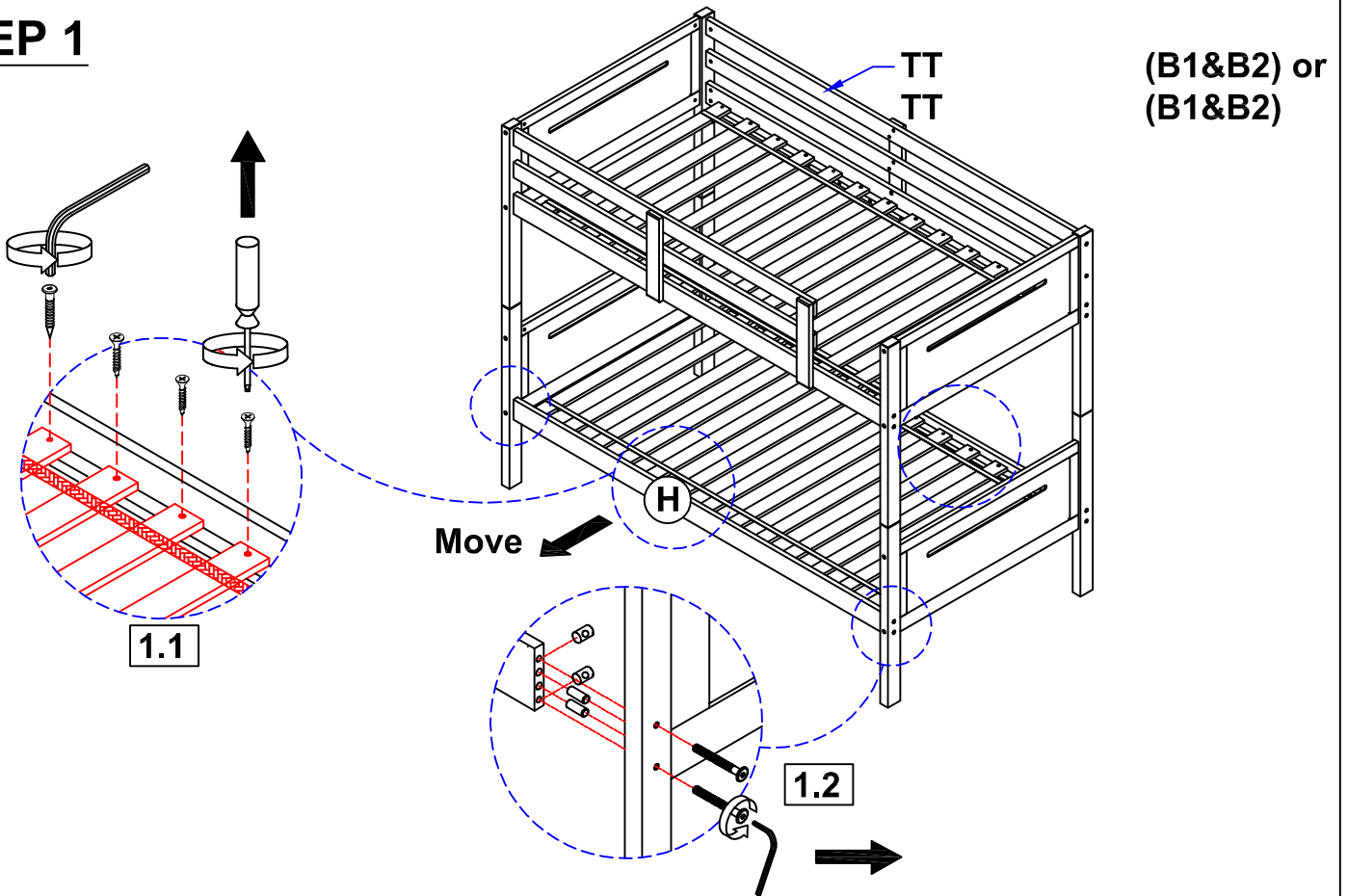

STEP 2

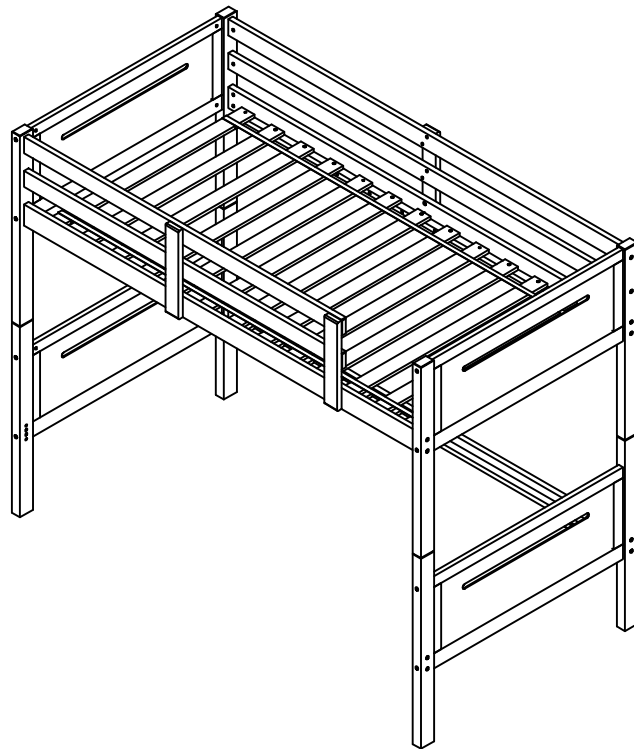

ASSEMBLY INSTRUCTIONS

STEP 3

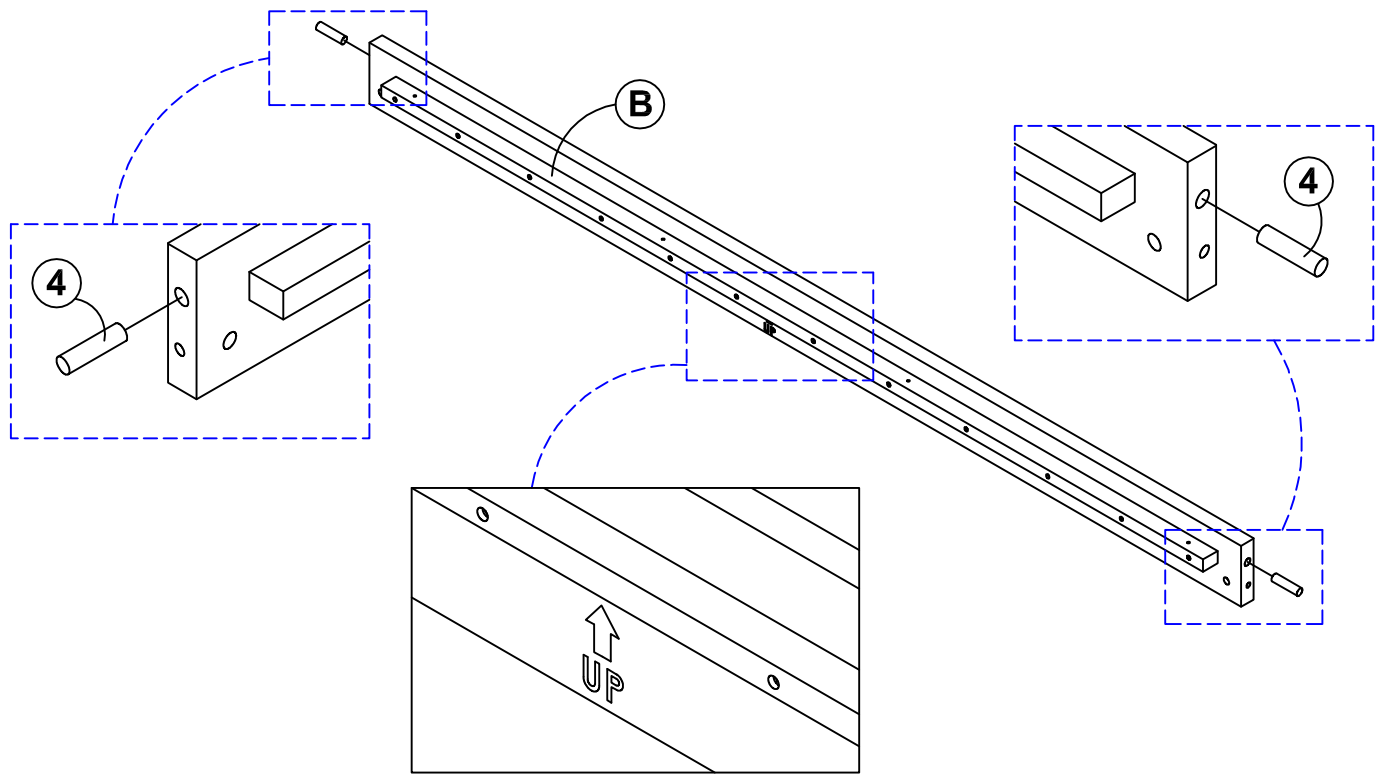

STEP 4

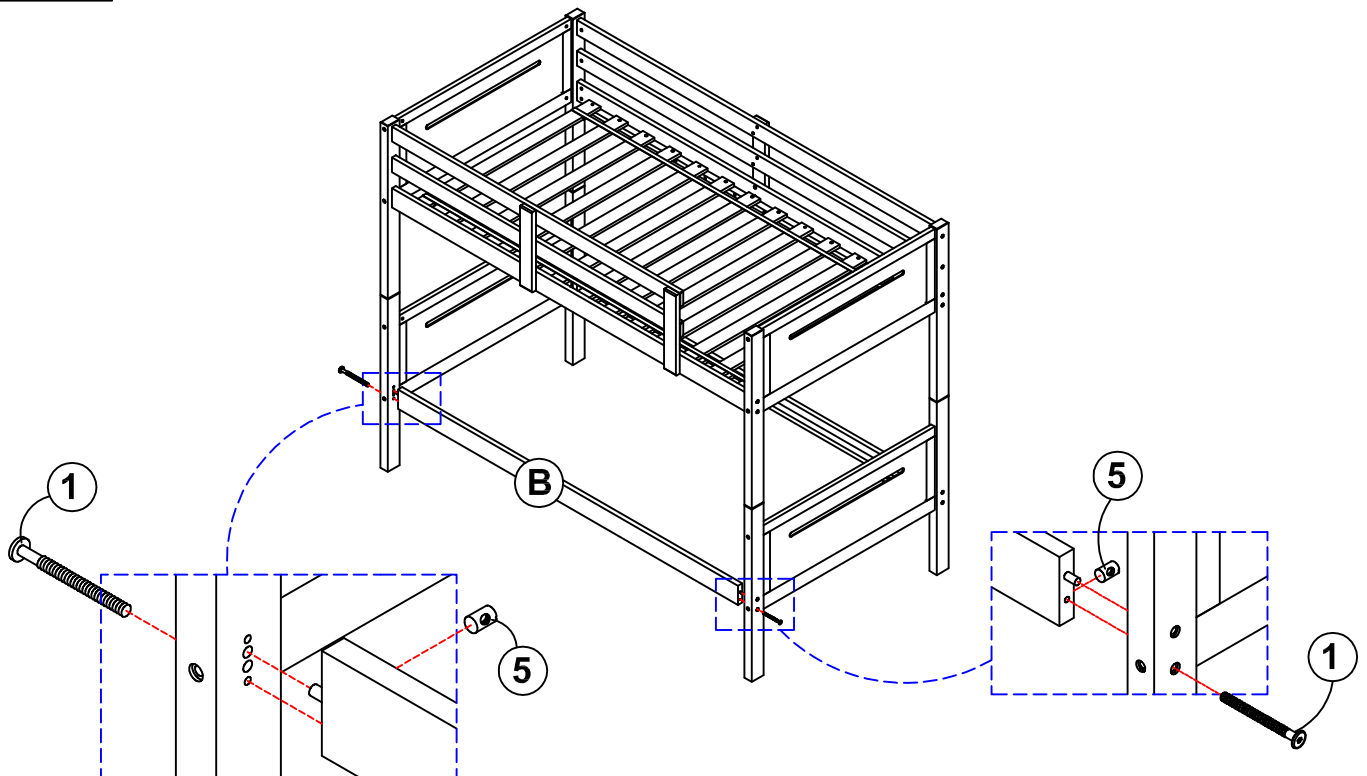

ASSEMBLY INSTRUCTIONS

STEP 5

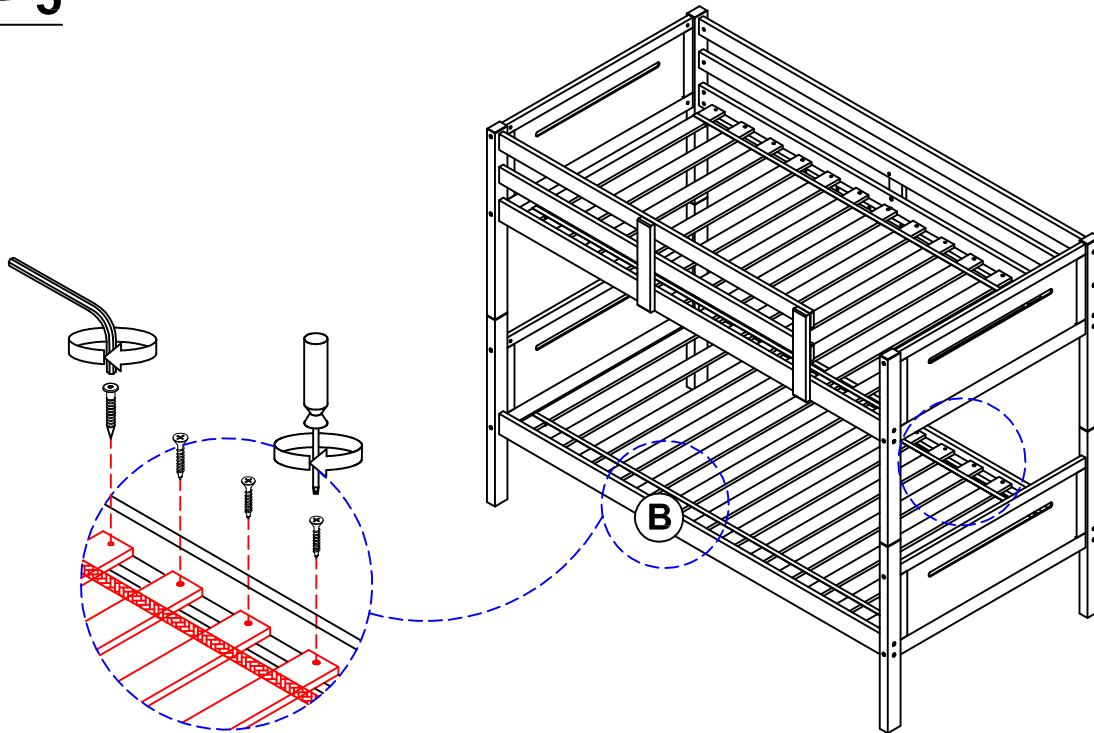

STEP 6

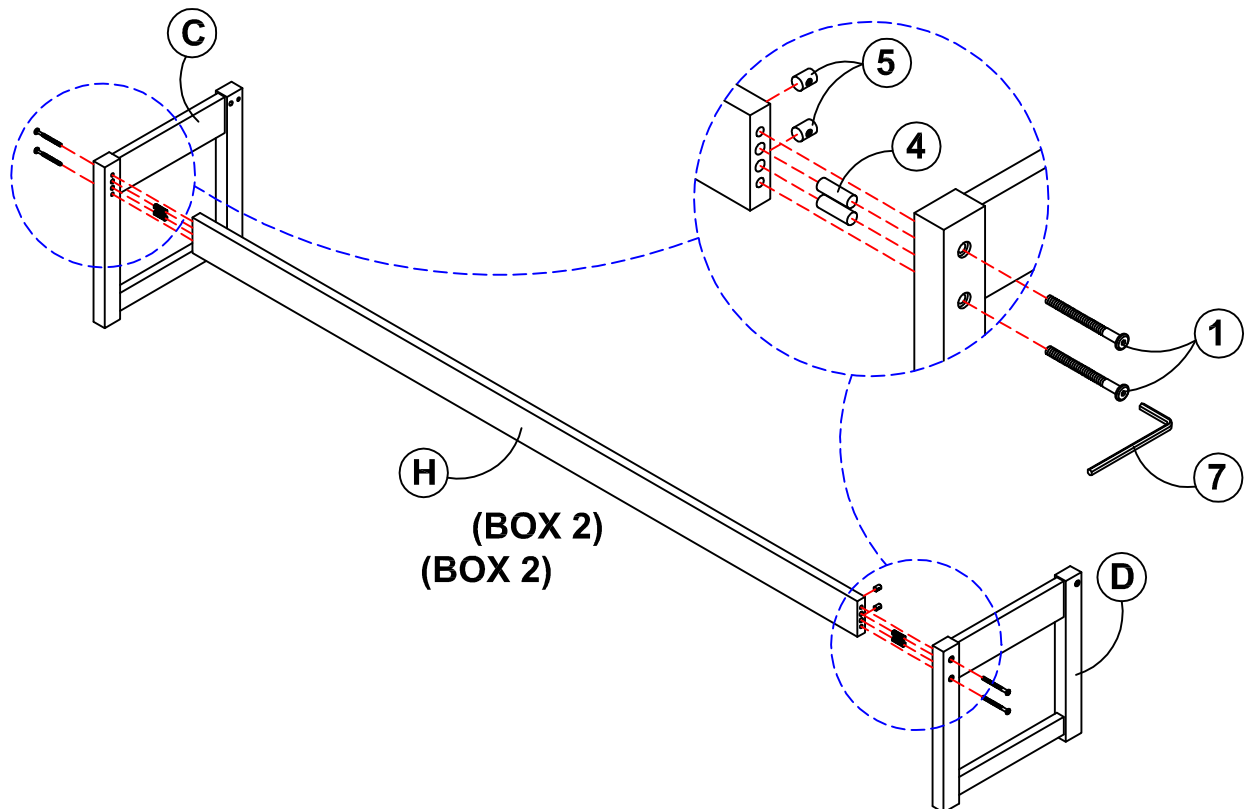

ASSEMBLY INSTRUCTIONS

STEP 7

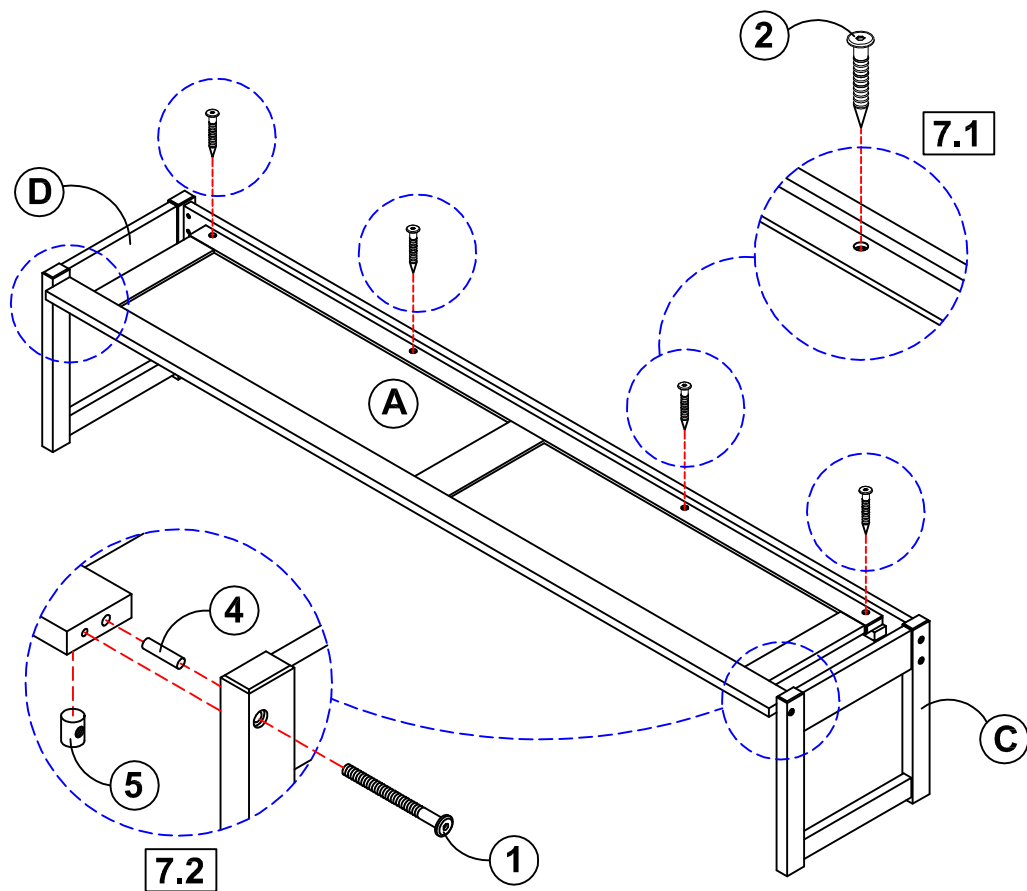

STEP 8

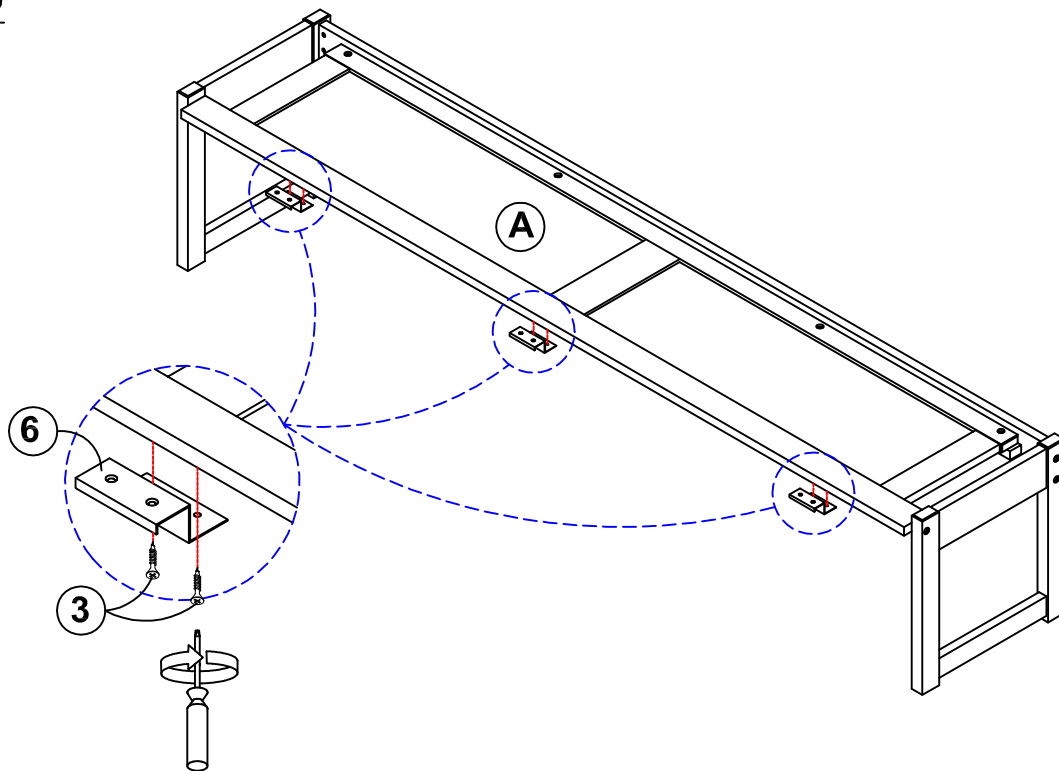

ASSEMBLY INSTRUCTIONS

STEP 9

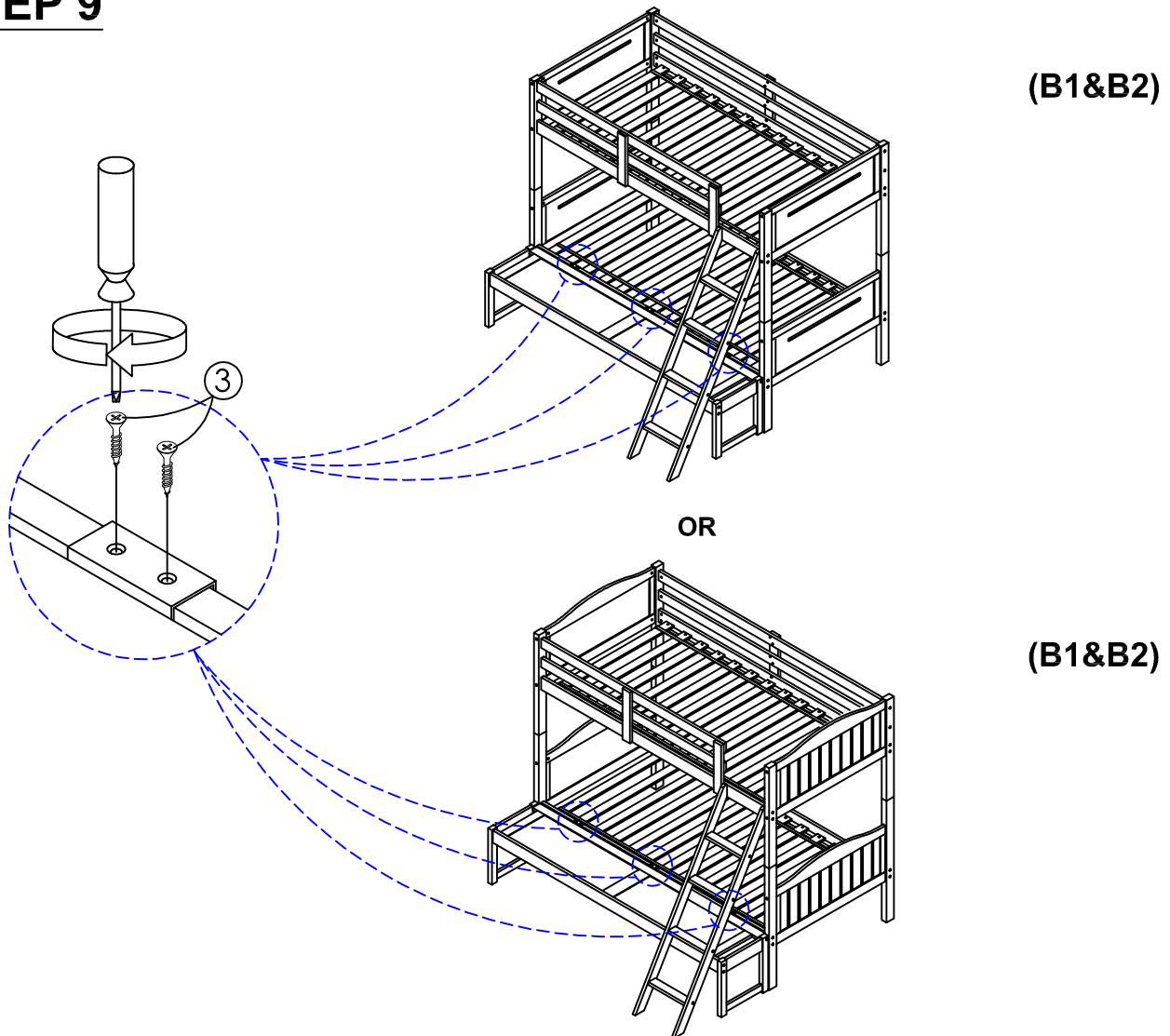

STEP 10 COMPLETE

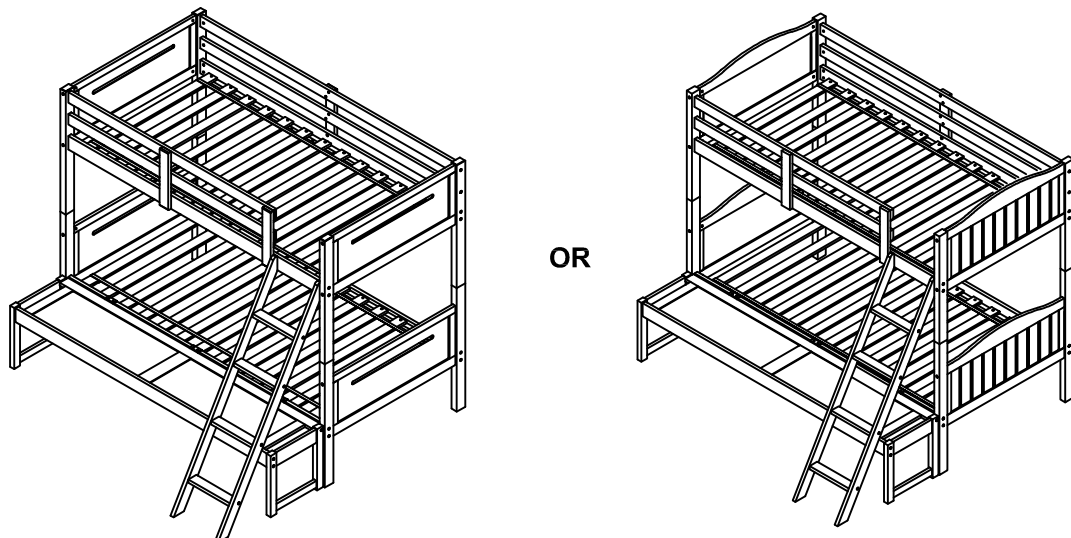

ASSEMBLY INSTRUCTIONS

SIZE OF MATTRESS

The length and width of the bunk mattress are as follow :

	<u>Length</u>	<u>Width</u>	<u>Thickness</u>
Upper bunk	74" - 75"	37 1/2" - 38 1/2"	6" Maximum
Lower bunk	74" - 75"	53" - 54"	6" Maximum

Ensure thickness of mattress does not exceed 6" and there must be at least 5" from mattress sleeping surface to top edge of guardrail.



SAFETY WARNING



1. Follow the information on the warnings appearing on the upper bunk end structure and on the carton. Do not remove warning label from bed.
 2. Always use the recommended size mattress or mattress support, or both, to help prevent the likelihood of entrapment or falls.
 3. Surface of mattress must be at least 5 in. (127 mm) below the upper edge of guardrails.
 4. Do not allow children under 6 years of age to use the upper bunk.
 5. Prohibit more than one person on upper bunk.
 6. Periodically check and ensure that the guardrail, ladder, and other components are in their proper position, free from damage, and that all connectors are tight.
 7. Do not allow horseplay on or under the bed and prohibit jumping on the bed.
 8. Always use the ladder for entering and leaving the upper bunk.
 9. Do not use substitute parts. Contact the manufacturer or dealer for replacement parts.
 10. Use of a night light may provide added safety precaution for a child using the upper bunk.
 11. Always use guardrails on both long sides of the upper bunk. If the bunk bed will be placed next to the wall, the guardrail that runs the full length of the bed should be placed against the wall to prevent entrapment between the bed and wall.
 12. The use of water or sleep flotation mattresses is prohibited.
 13. Keep these instructions for future reference.
- STRANGULATION HAZARD**
14. Never attach or hang items to any part of the bunk bed that are not designed for use with the bed; for example, but not limited to hooks, belts and jump ropes.

REPLACEMENT PART :

Replacement part, including additional guardrails may be obtained from any Dealer.

ASSEMBLY INSTRUCTIONS



⚠ WARNING ⚠
TO PREVENT SERIOUS OR FATAL INJURY

1. When using beds as bunk beds, the ladder **MUST** be securely attached to the upper bunk rail at all times.
2. When using the beds as two (2) separate floor-standing beds, the ladder **MUST** be stored in a separate location where children cannot use the ladder in any manner.
3. **DO NOT** use, nor permit children to use, the ladder in any manner whatsoever, other than to access the top unit when used as bunk beds, and only if the ladder is securely attached to the top bunk rail, as set forth in the instructions.
4. Any misuse or unauthorized use of the ladder could result in serious or fatal injury.
5. Failure to follow the above **WARNING**, and/or failure to follow assembly instructions completely, will void any and all liability of () for damages and injury to persons and property.

TWIN/FULL BUNK BED

Inner Size (Upper) : 76.00"W X 38.75"D

Inner Size (Lower) : 76.00"W X 54.00"D

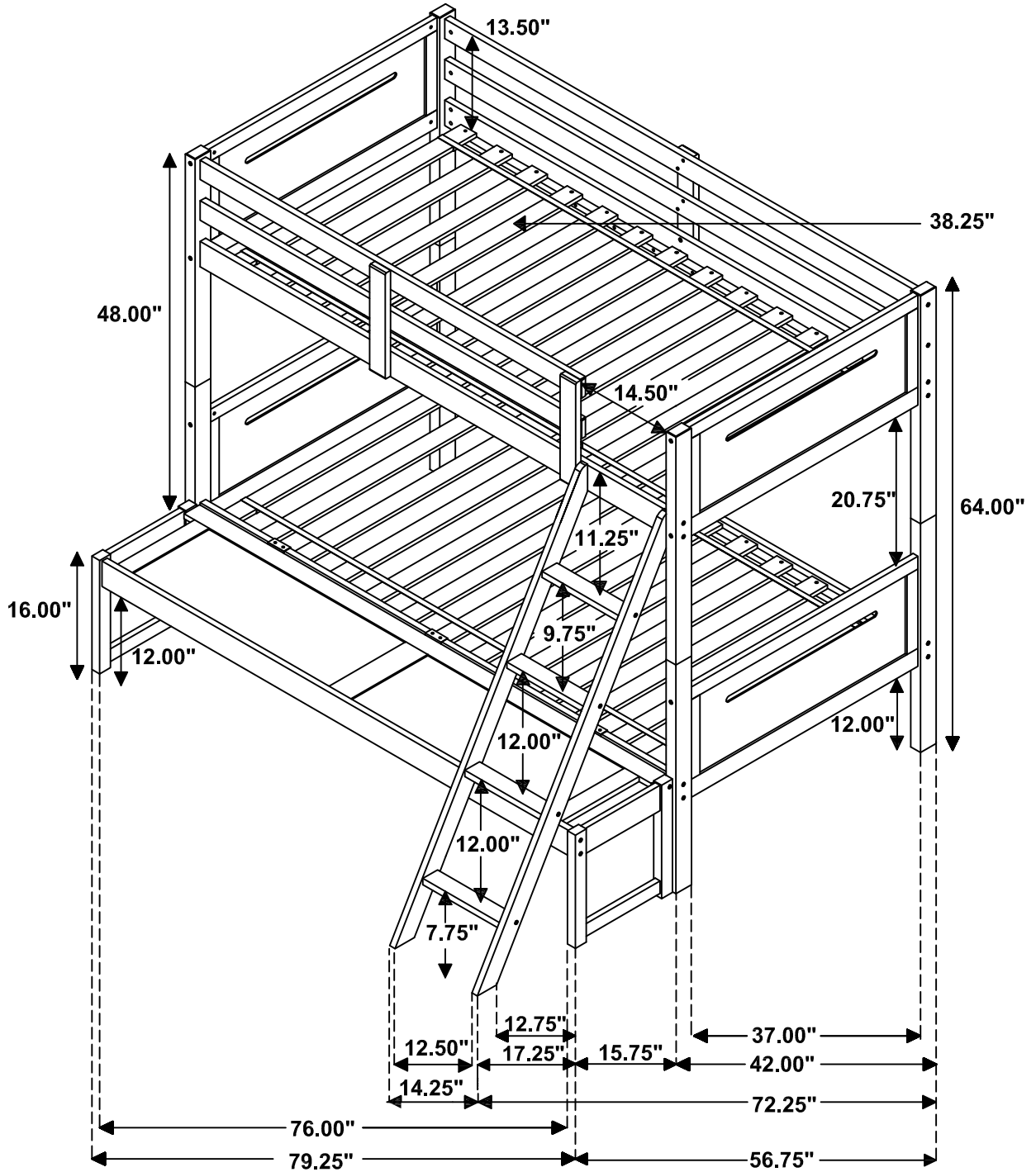

Note : Dimension tolerance $\pm 5\%$

TWIN/FULL BUNK BED

Inner Size (Upper) : 76.00"W X 38.75"D

Inner Size (Lower) : 76.00"W X 54.00"D

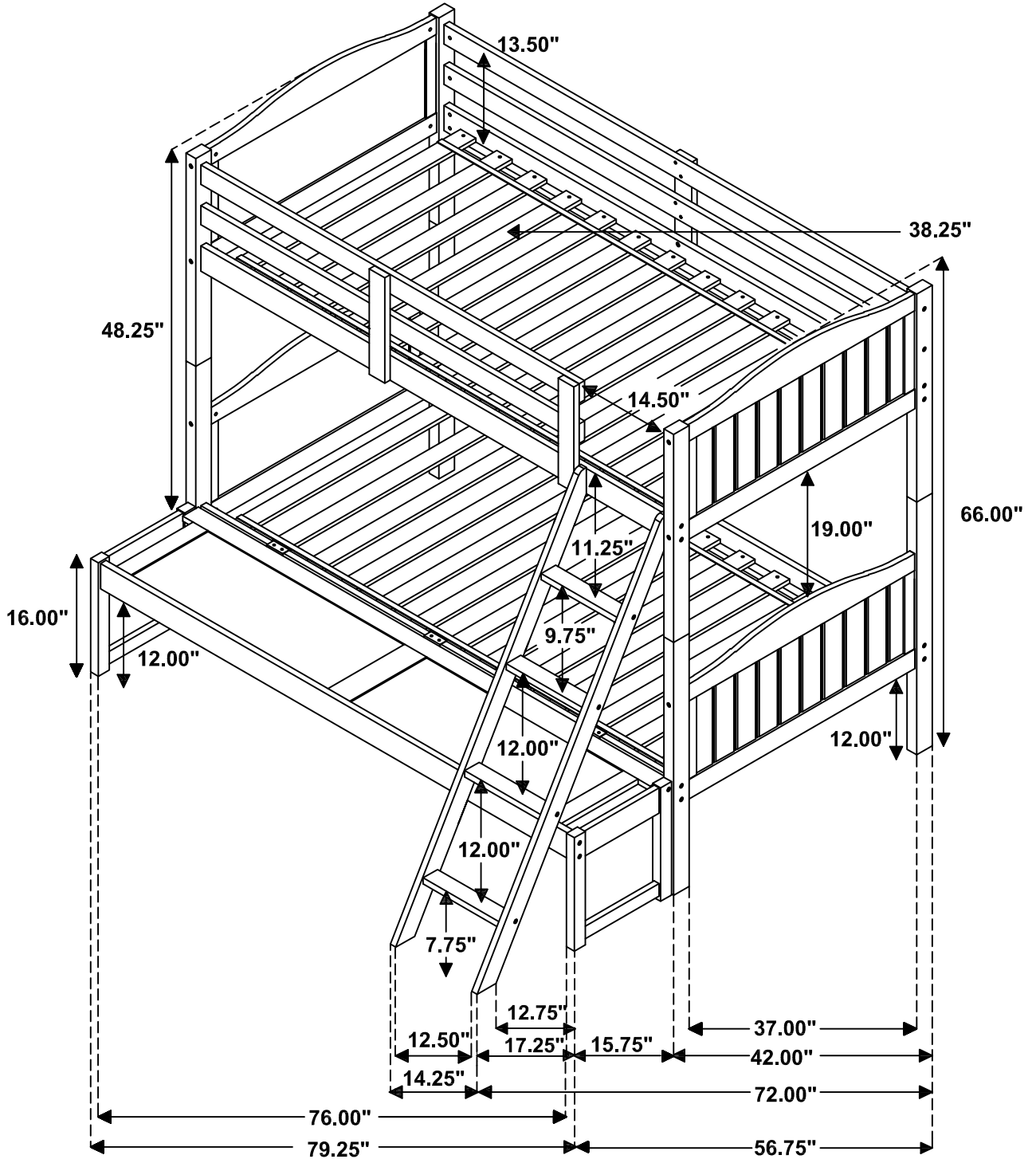

Note : Dimension tolerance $\pm 5\%$