

Assembly Instructions

Executive Desk

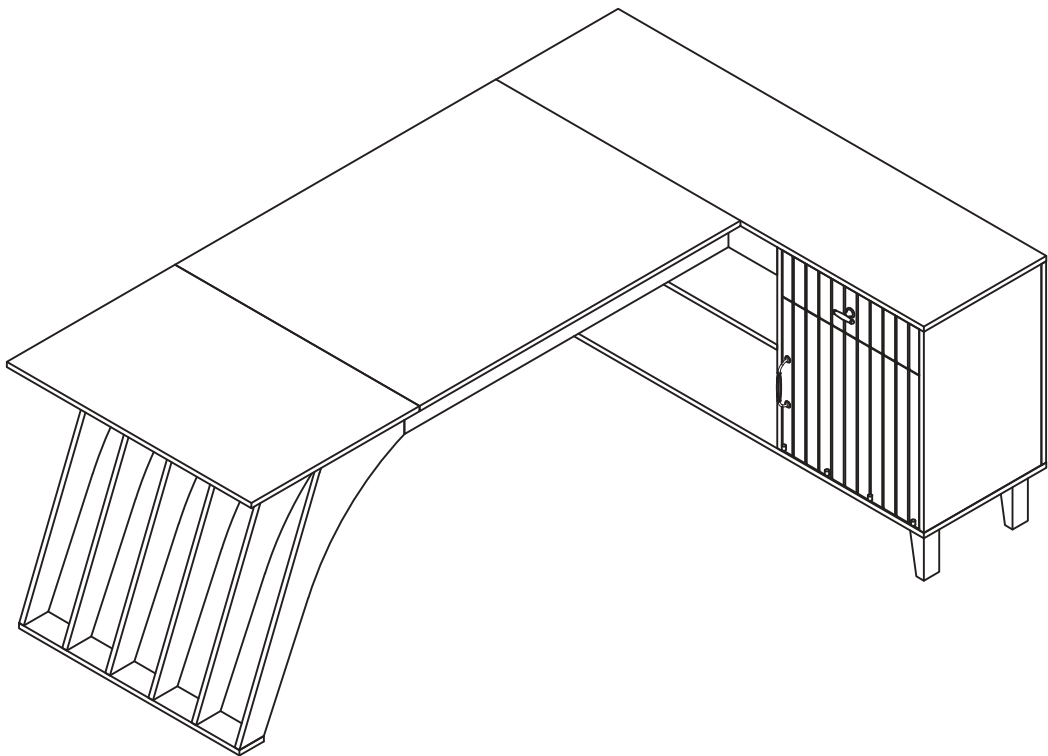

Contact Us

We're here to help you.

Your satisfaction is our top priority. If you encounter any issues with this product, such as missing or damaged parts, we're here to help. Please retain the original packaging and take photos of the packaging and the product, then contact us as soon as possible.

Warm Tips

1. Carefully read these instructions and keep them for future reference.
2. Check the parts list and confirm everything's there before starting assembly.
3. When assembling, put all parts on a soft, smooth surface like a carpet to avoid scratches.
4. Don't fully tighten screws until all parts are confirmed in place to avoid misalignment.

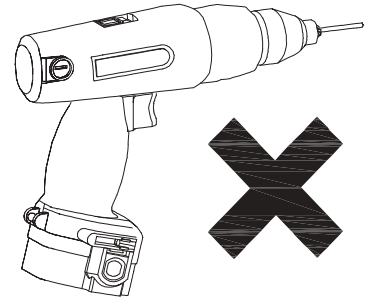
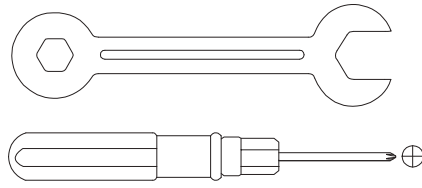
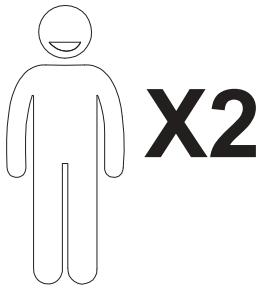

We recommend using hand tools for assembly.

If an electric screwdriver is used, reduce power and torque to avoid damage to the product.

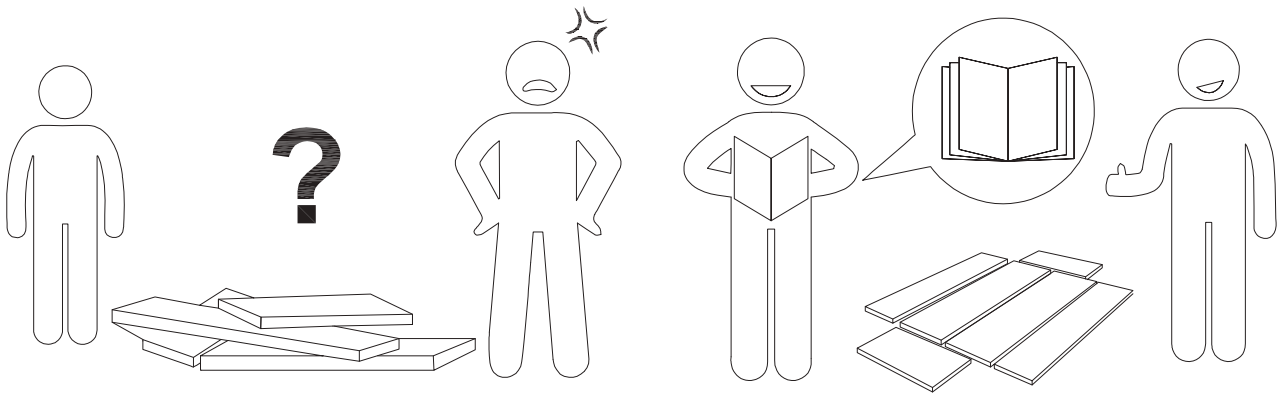

AVOID SCRATCHES

In order to avoid scratching, this furniture should be assembled on a soft surface, such as a rug.

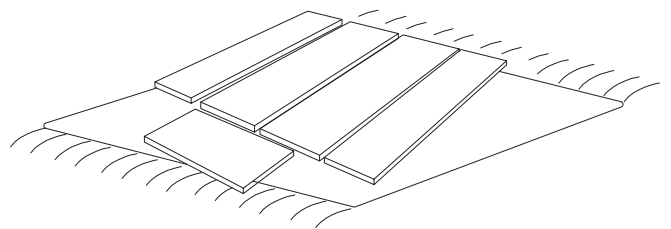
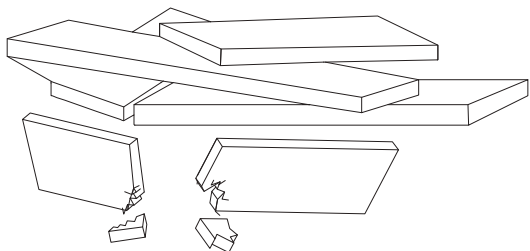

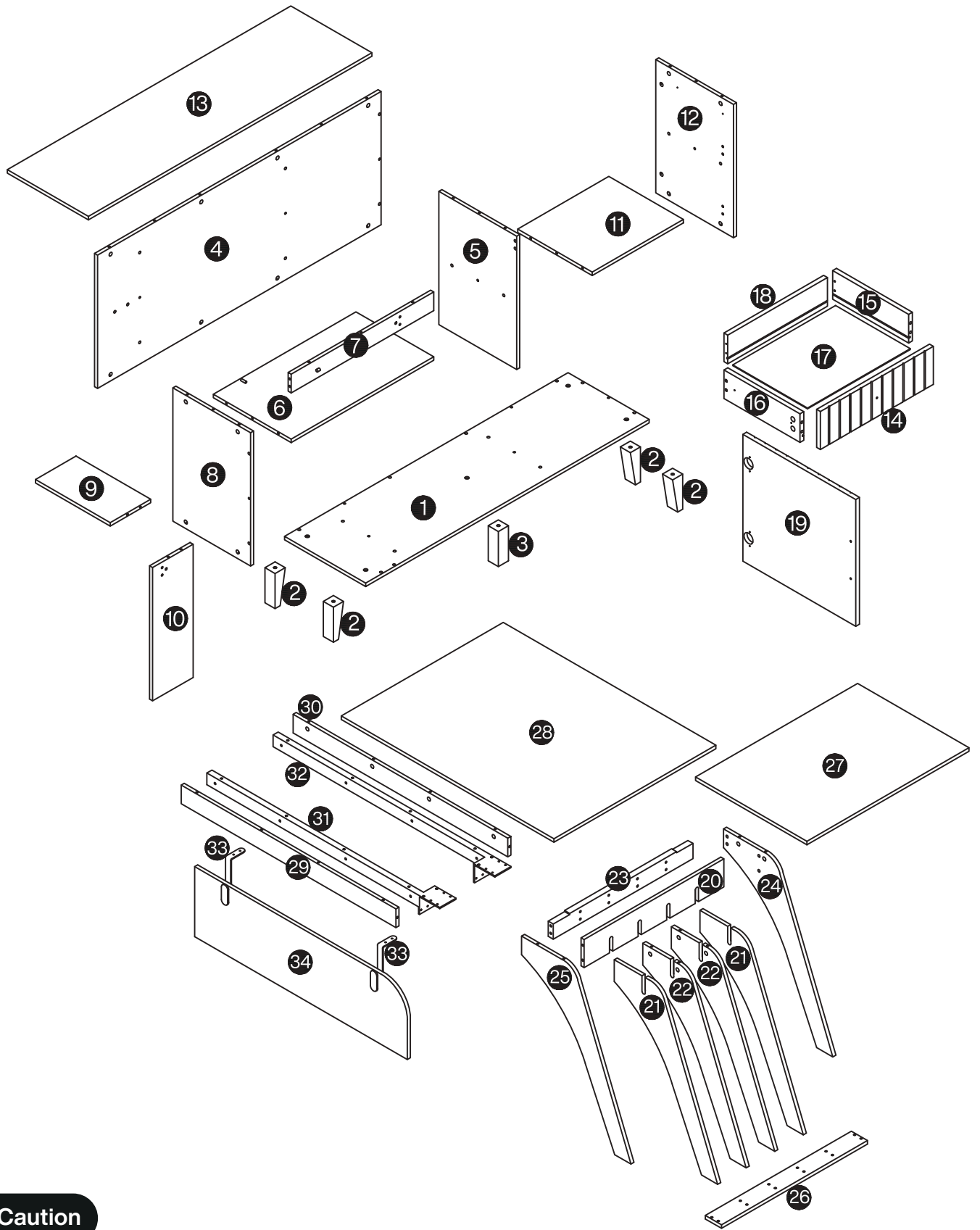



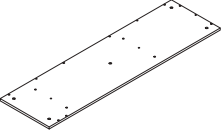

⚠ Caution

Make sure all parts are included. Most board parts are labeled or stamped on the raw edge. Contact us for a free replacement if you encounter any damaged or missing parts.

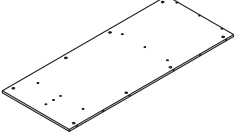
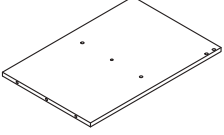
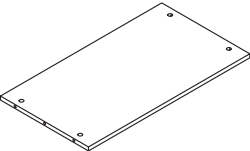
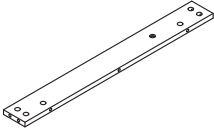
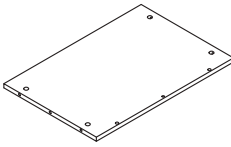
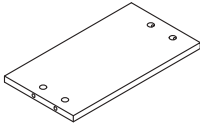
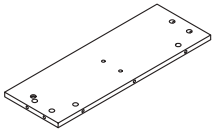
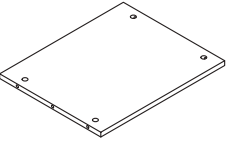
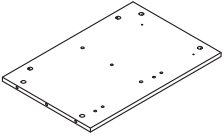
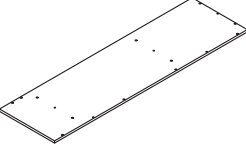
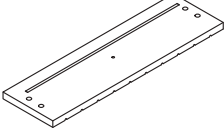
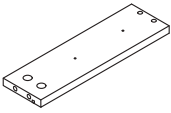
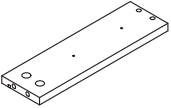
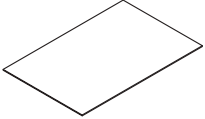
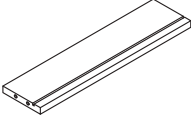
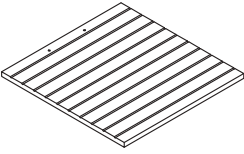
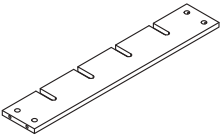
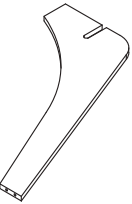
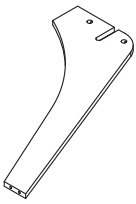
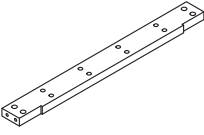
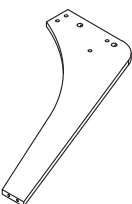
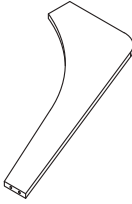

Parts List

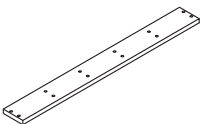
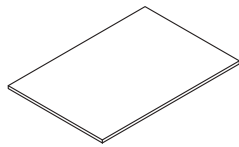
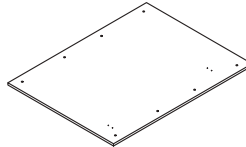
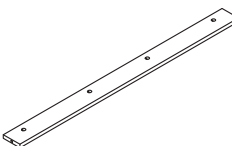
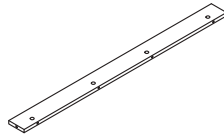
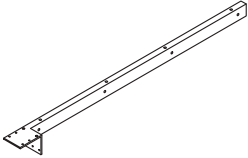
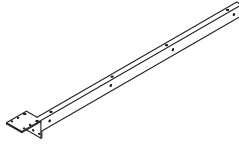
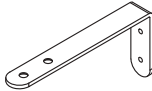
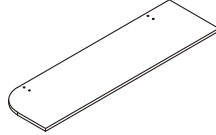

<p>1</p>  <p>1 pc</p>	<p>2</p>  <p>4 pcs</p>	<p>3</p>  <p>1 pc</p>	<p>4</p>  <p>1 pc</p>	<p>5</p>  <p>1 pc</p>
<p>6</p>  <p>1 pc</p>	<p>7</p>  <p>1 pc</p>	<p>8</p>  <p>1 pc</p>	<p>9</p>  <p>1 pc</p>	<p>10</p>  <p>1 pc</p>
<p>11</p>  <p>1 pc</p>	<p>12</p>  <p>1 pc</p>	<p>13</p>  <p>1 pc</p>	<p>14</p>  <p>1 pc</p>	<p>15</p>  <p>1 pc</p>
<p>16</p>  <p>1 pc</p>	<p>17</p>  <p>1 pc</p>	<p>18</p>  <p>1 pc</p>	<p>19</p>  <p>1 pc</p>	<p>20</p>  <p>1 pc</p>
<p>21</p>  <p>2 pcs</p>	<p>22</p>  <p>2 pcs</p>	<p>23</p>  <p>1 pc</p>	<p>24</p>  <p>1 pc</p>	<p>25</p>  <p>1 pc</p>

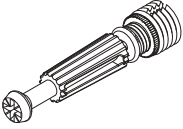
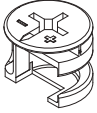
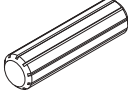
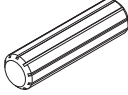

Parts List

<p>26</p>  <p>1 pc</p>	<p>27</p>  <p>1 pc</p>	<p>28</p>  <p>1 pc</p>	<p>29</p>  <p>1 pc</p>	<p>30</p>  <p>1 pc</p>
<p>31</p>  <p>1 pc</p>	<p>32</p>  <p>1 pc</p>	<p>33</p>  <p>2 pcs</p>	<p>34</p>  <p>1 pc</p>	<p>35</p> 

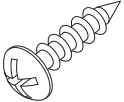
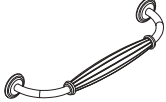
Hardware List

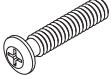
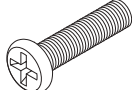
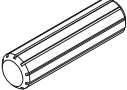
A	B	C	D	E	F
					
M6x40mm	Ø15x12mm	Ø8x40mm	Ø8x50mm	Ø3.5x35mm	Ø3.5x14mm
78 pcs	78 pcs	2 pcs	1 pc	12 pcs	64 pcs

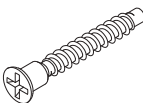
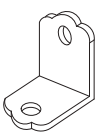
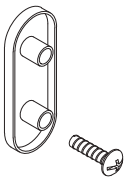
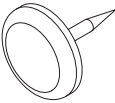
G	H	I	J	K	L
					
Ø4x14mm	128#		M4x18mm	M8x30mm	Ø8x30mm
4 pcs	1 pc	1 pc	3 pcs	7 pcs	22 pcs

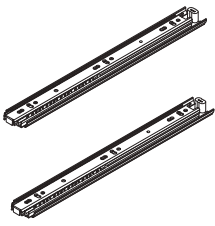
M	N	O	P	Q	R
					
M7x38mm		Ø5x15mm			12"
20 pcs	4 pcs	2 pcs	12 pcs	1 pc	1 sets

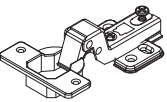
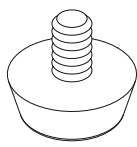
S	T				
					
2 pcs	1 pc				

Installation of Cams and Pins

Read each step carefully before starting. Each step of instruction should be performed in the correct order. If these steps are not followed in sequence, assembly difficulties may occur.

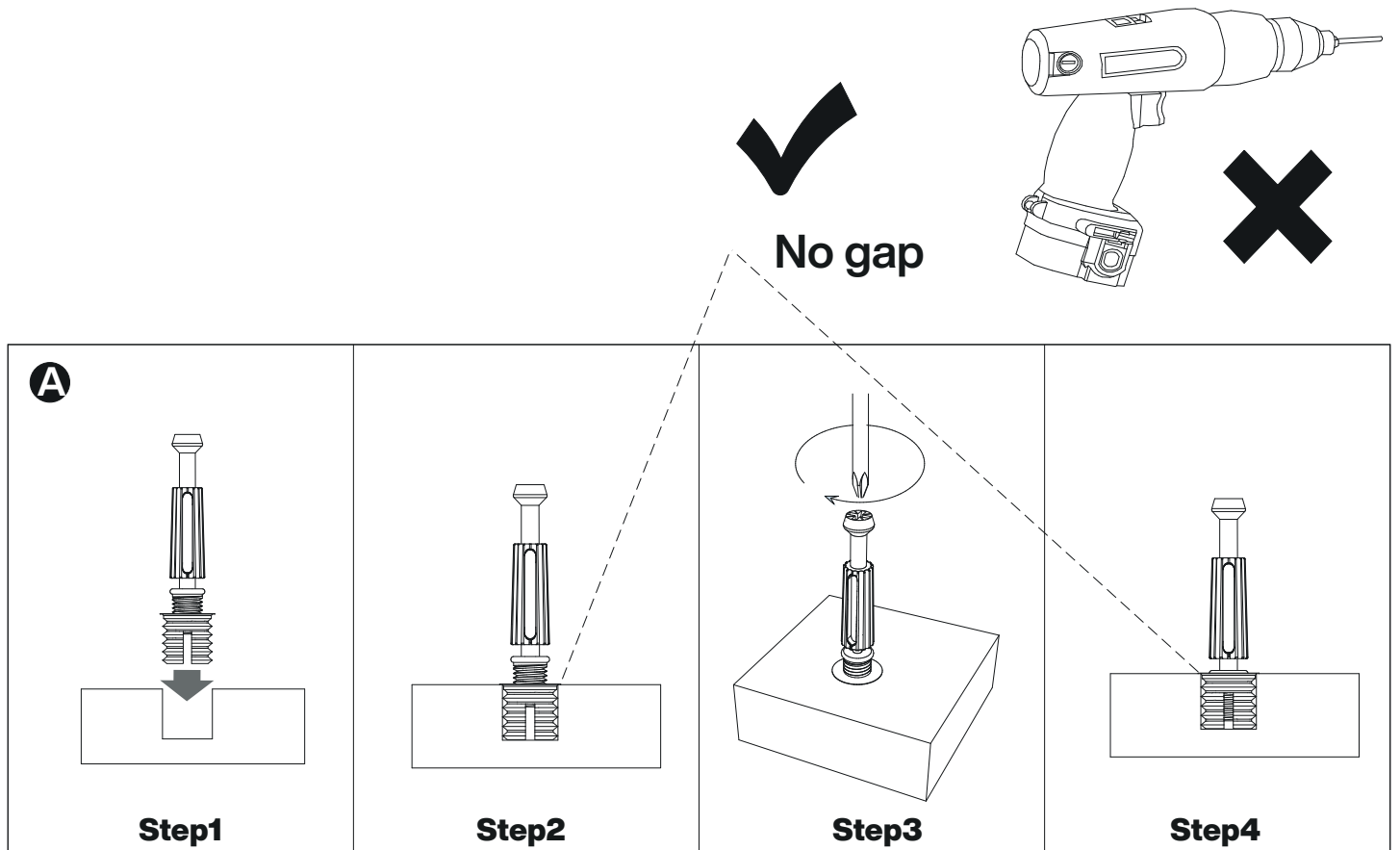

Screw the pin into the hole. Set the cams correctly by aligning the head of the cams with the lock pins. Lock the cam by turning the cam head with a screwdriver until it is tightened. Please do not use an electric screwdriver to assemble the unit.

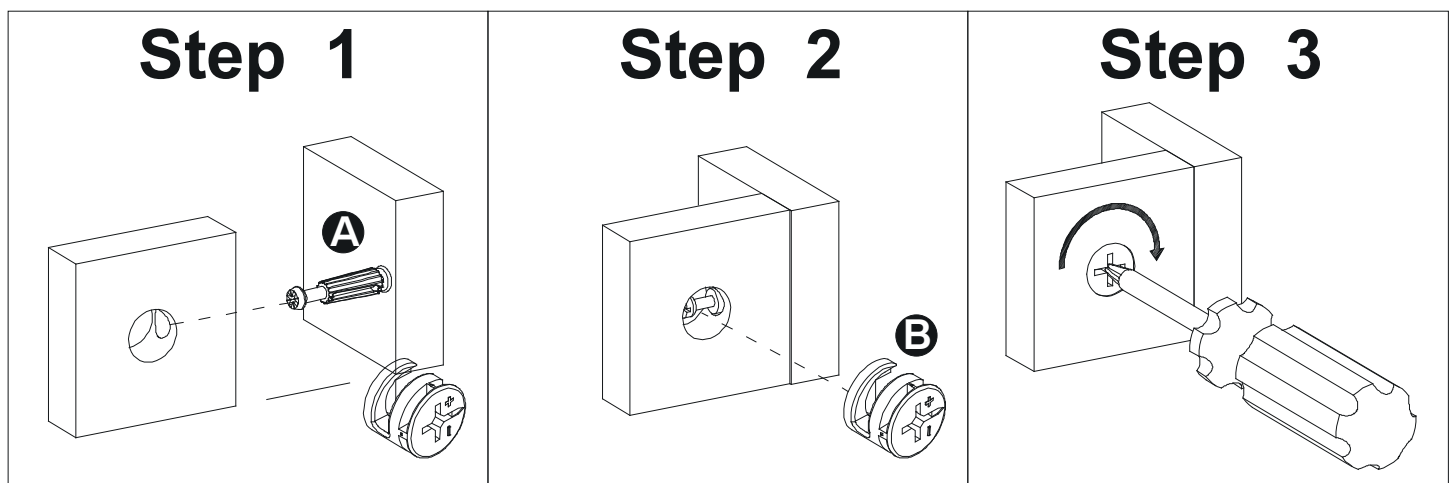

Please split component "R" into "R-1" and "R-2" before assembling the slide and then proceed to the next step of assembly

Step 1

Pull apart component "R" to each side, and then gently push up the lever of component "R-2"

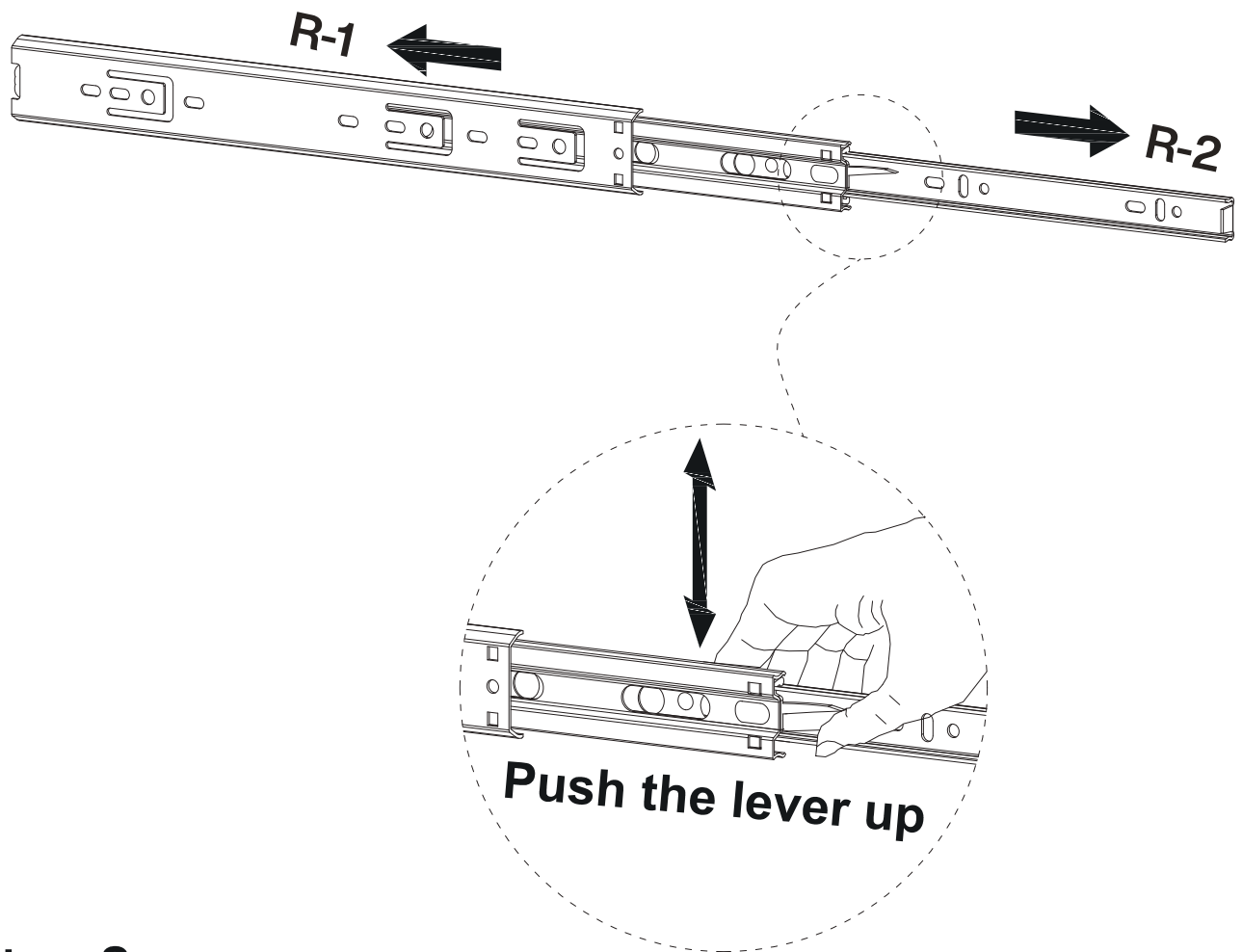

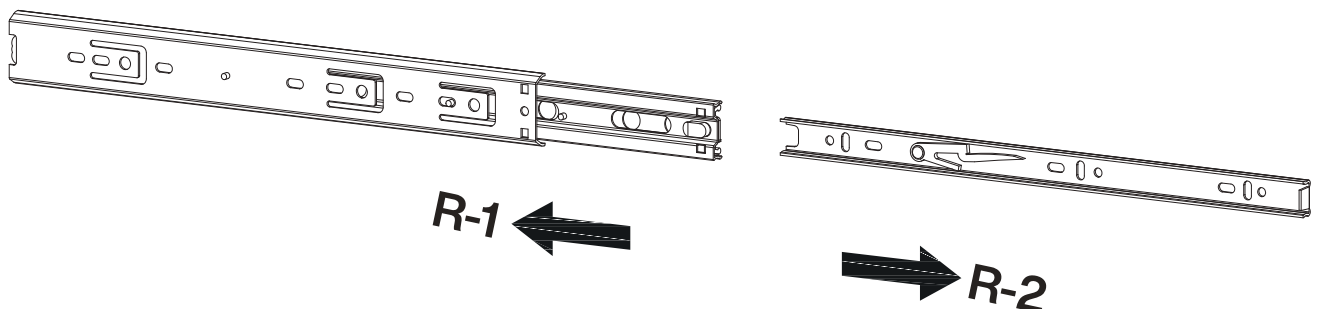

Step 2 Split component "R-1" and "R-2"

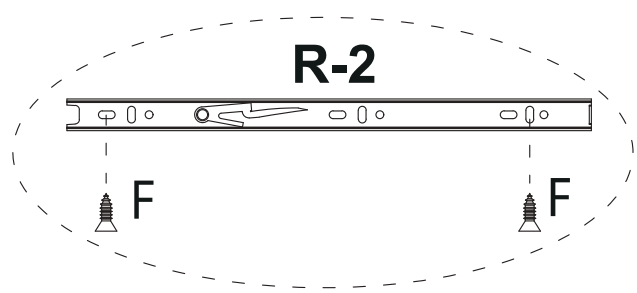

1



R-2	F
	 Ø3.5x14mm
1 pcs	4 pcs

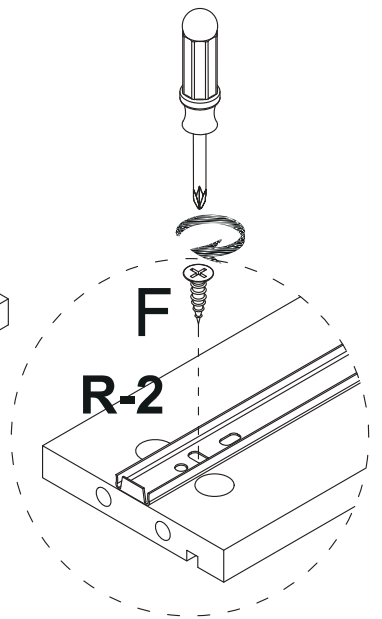
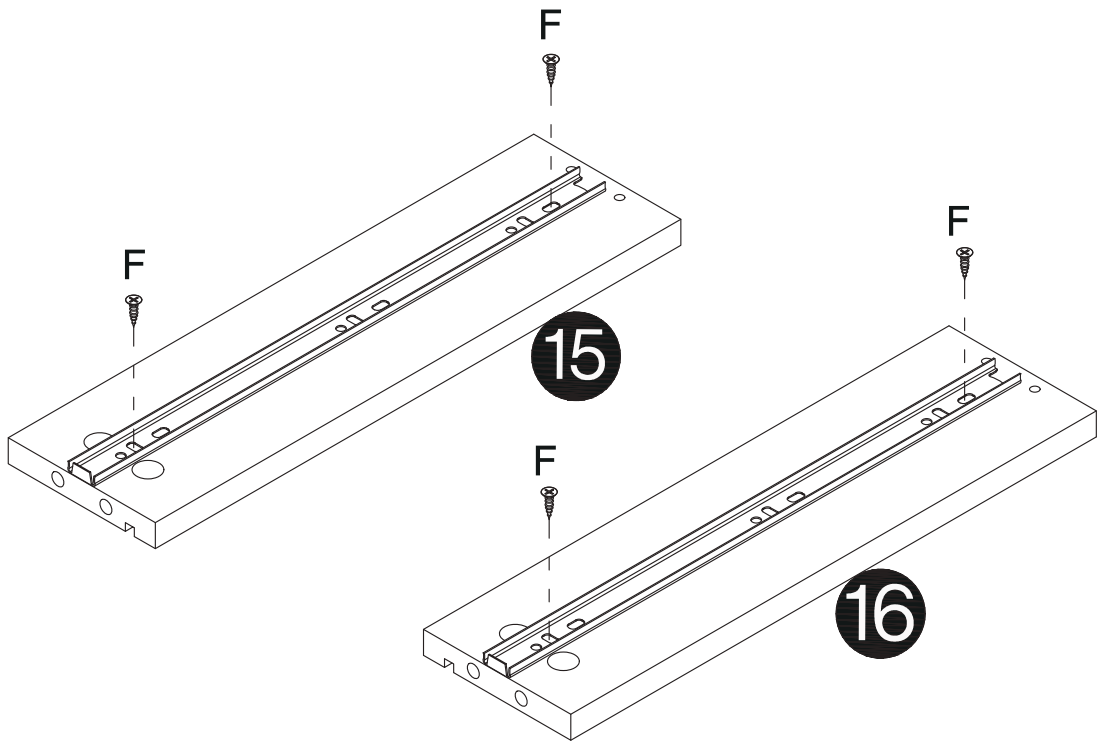

2

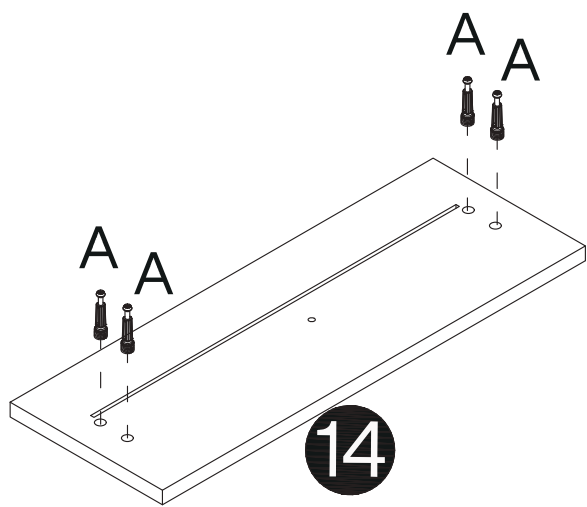

A
 M6x40mm
4 pcs

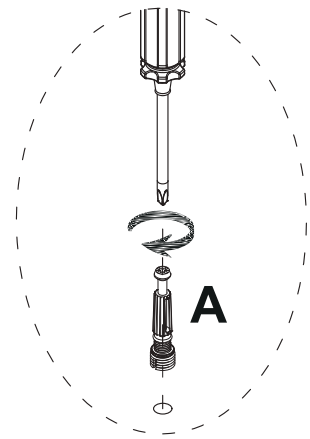

3

B

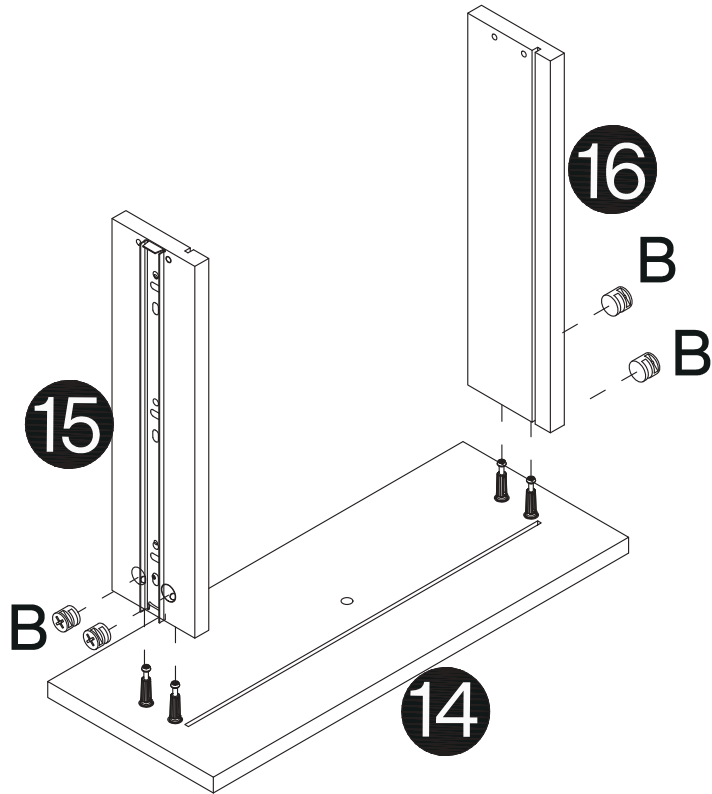
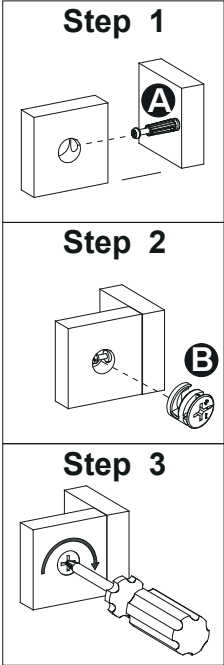
Ø15x12mm
4 pcs

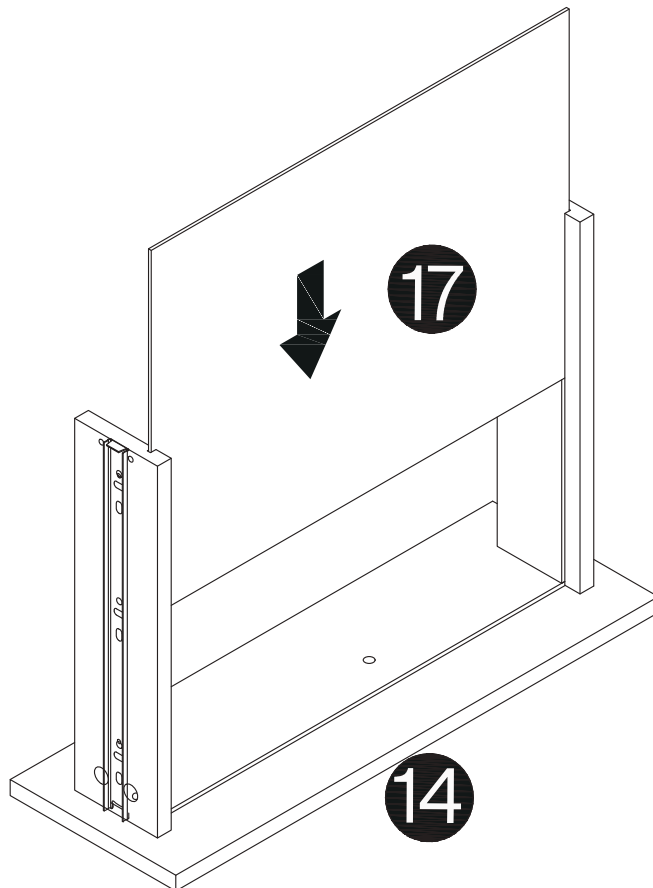

4

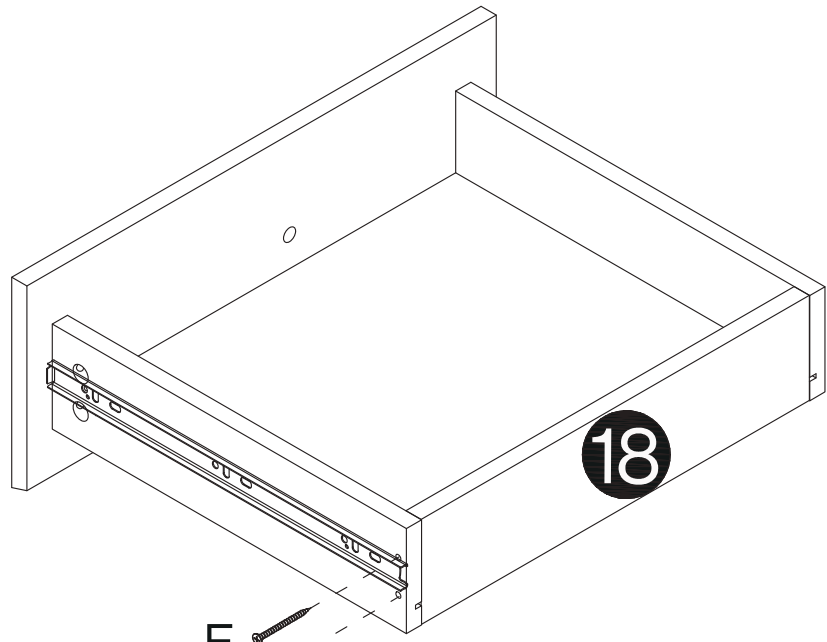

5



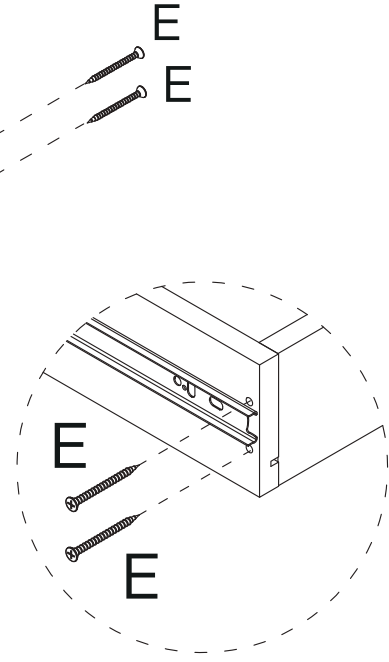

E

Ø3.5x35mm
4 pcs



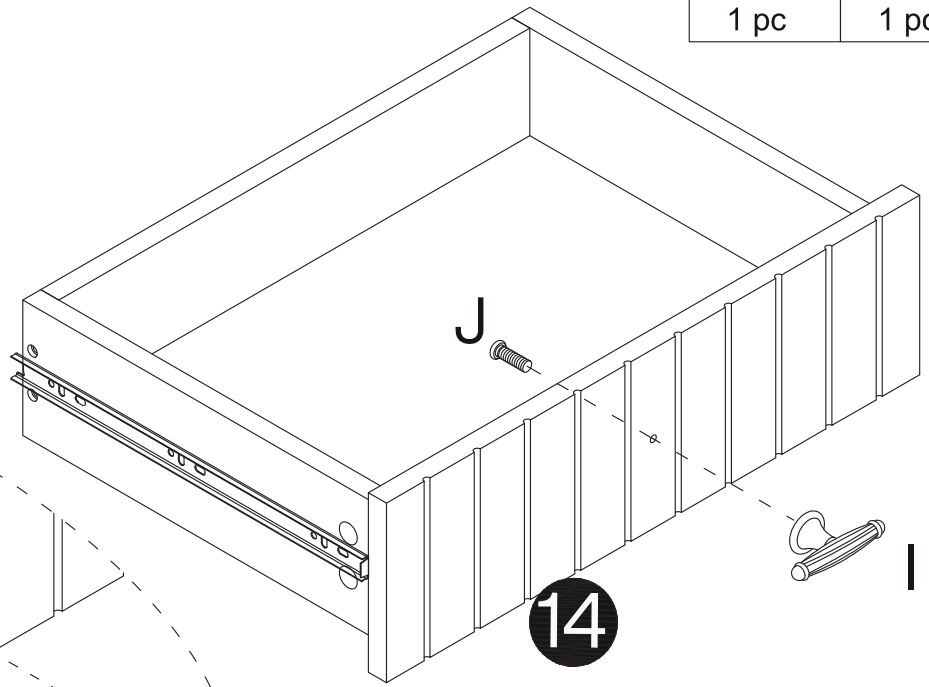

6

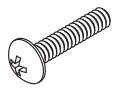

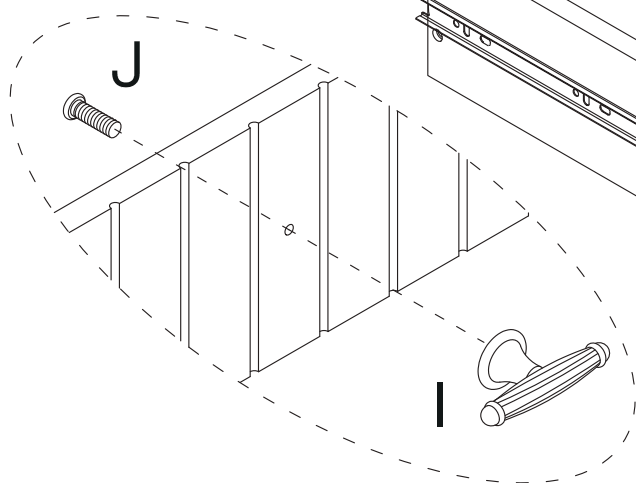
I	J
	
1 pc	M4x18mm
1 pc	1 pc



7

P	T
	
4 pcs	1 pc

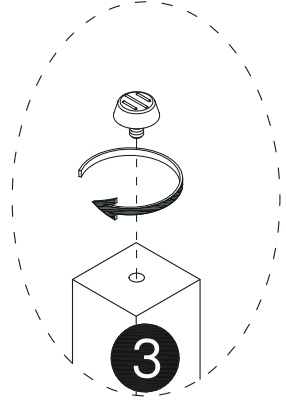
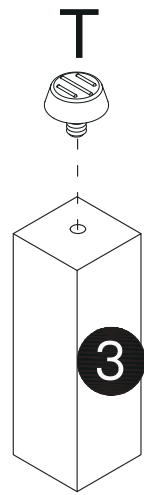
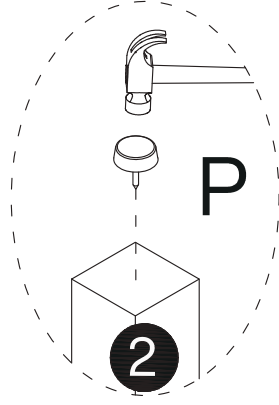
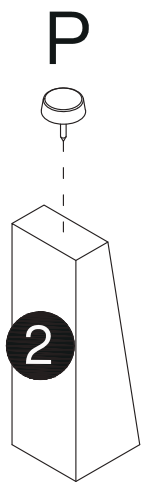

x4

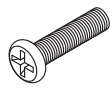

⚠ Caution! Tap lightly

8

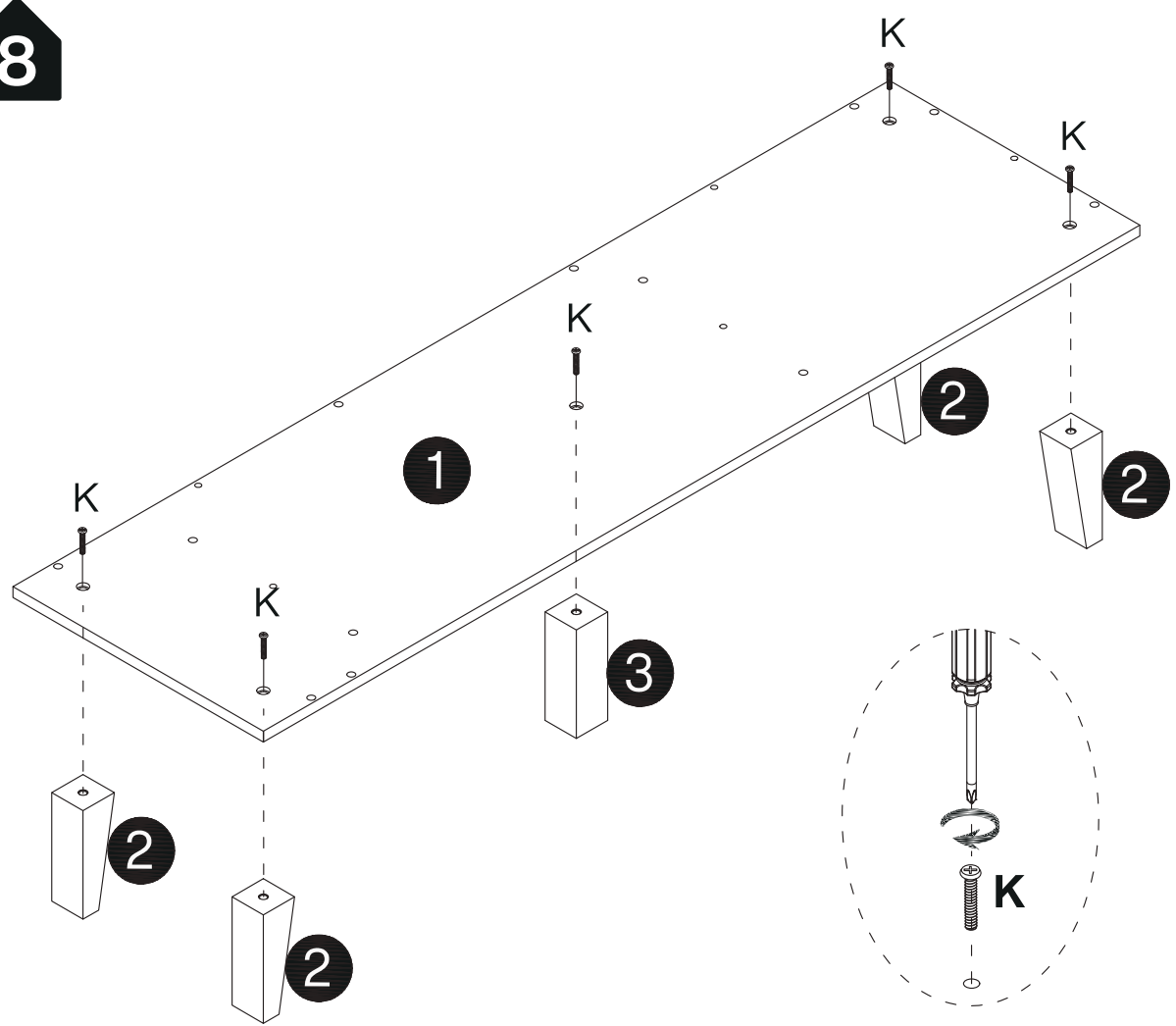
K

M8x30mm
5 pcs

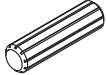

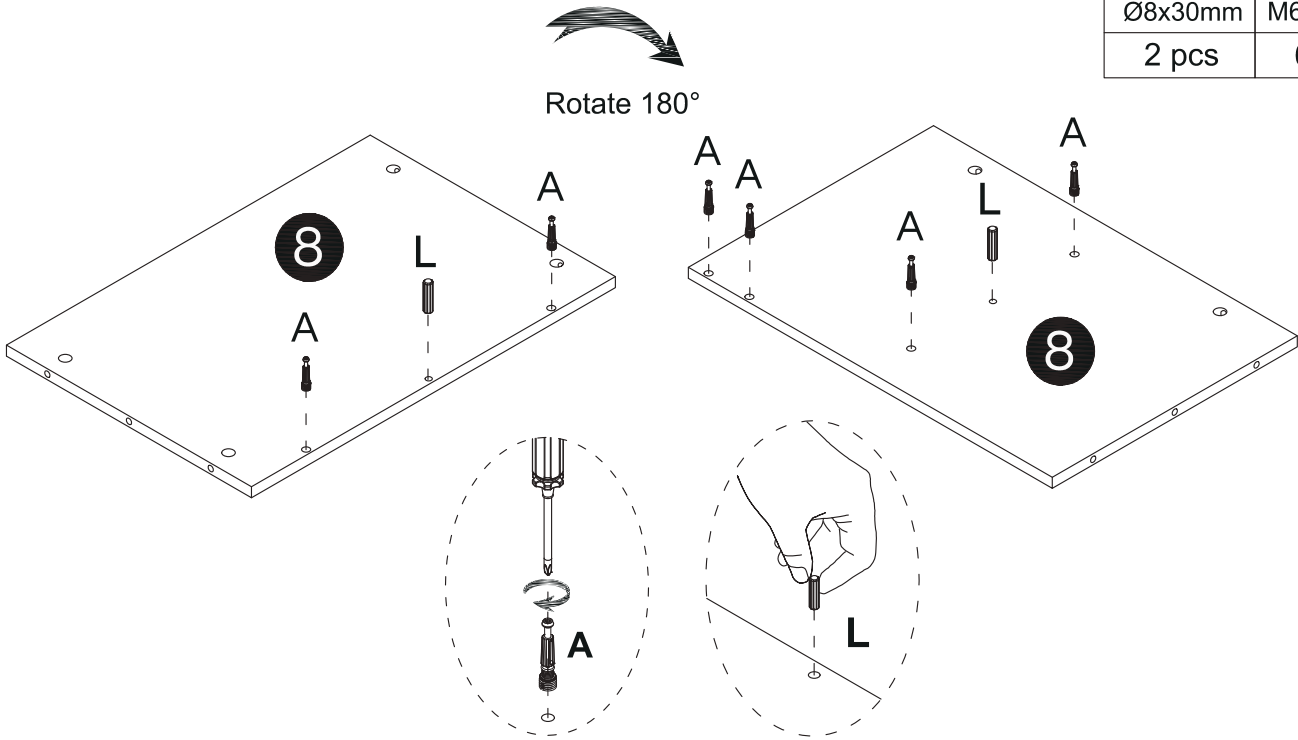

9

L	A
	
Ø8x30mm	M6x40mm
2 pcs	6 pcs



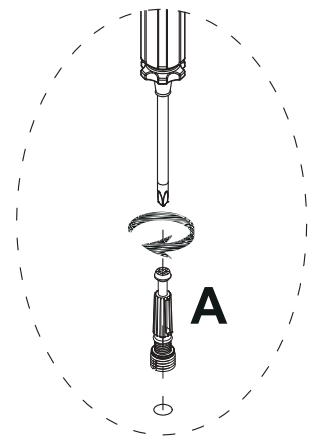
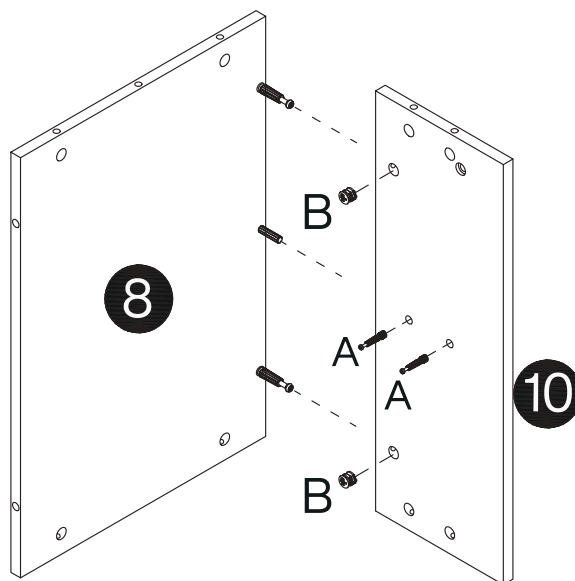
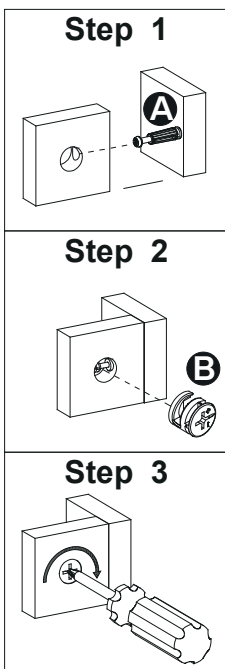

10

B	A
	
Ø15x12mm	M6x40mm
2 pcs	2 pcs

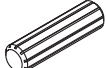

11



D	A
	
Ø8x50mm	M6x40mm
1pc	6pcs

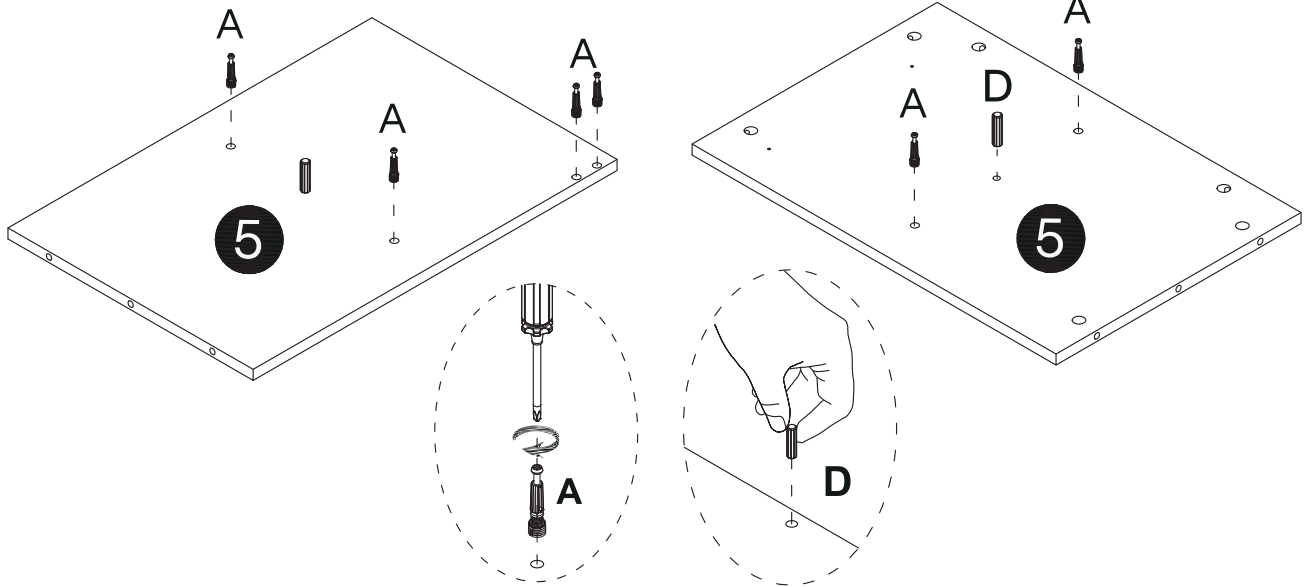

Rotate 180°



12

F	R-1
	
Ø3.5x14mm	
2pcs	1pc

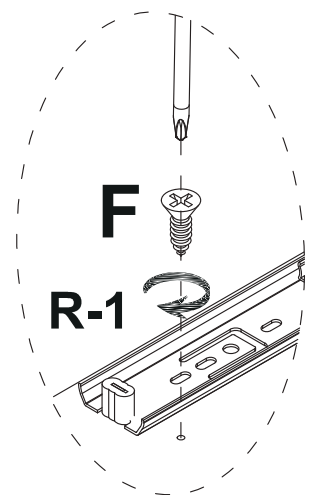
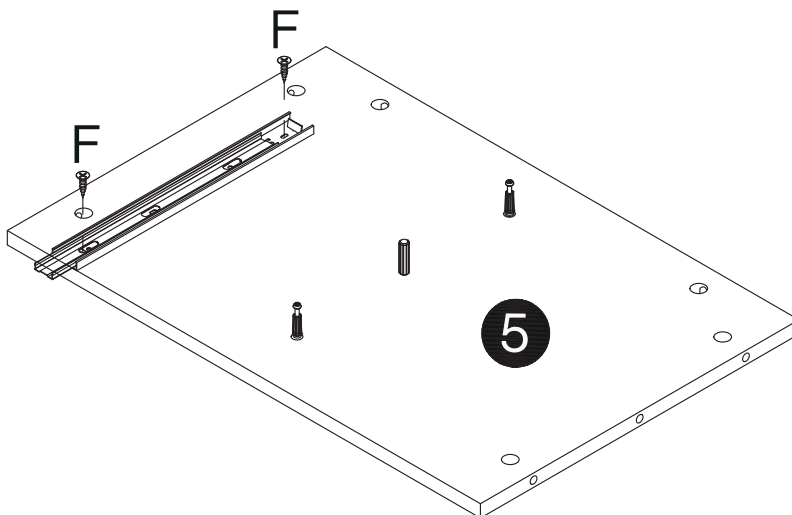
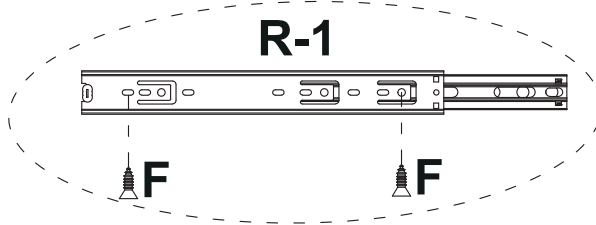

13

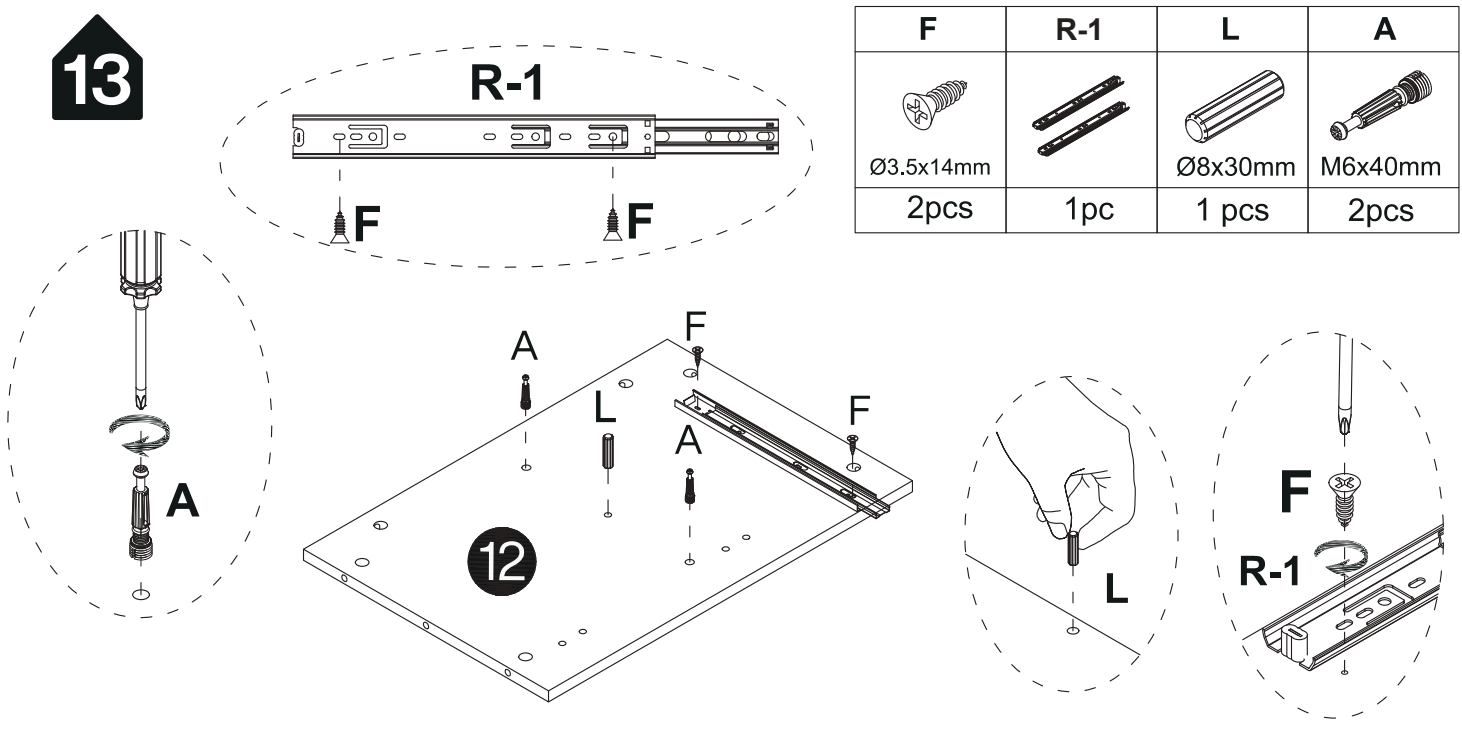

14

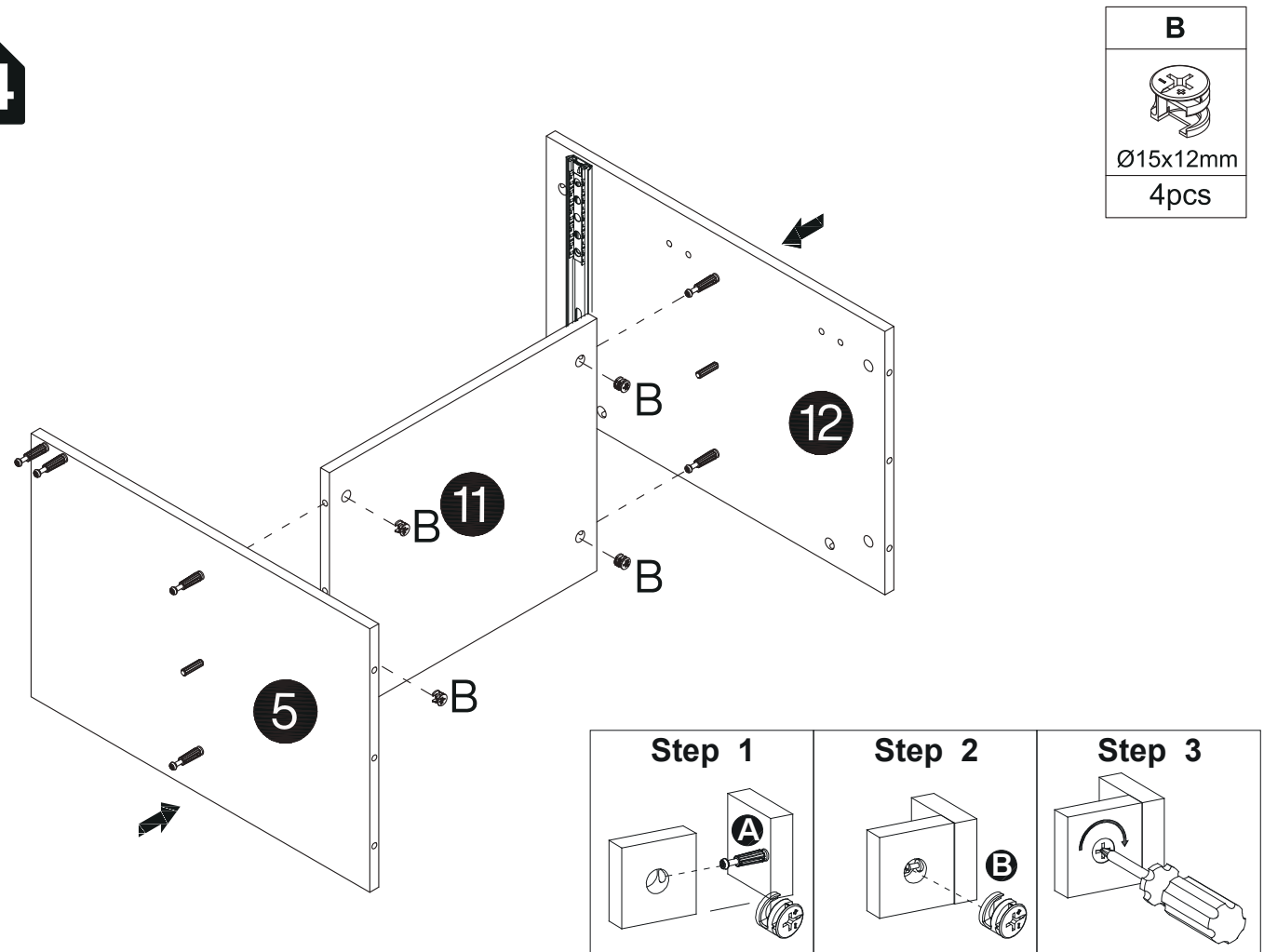

15

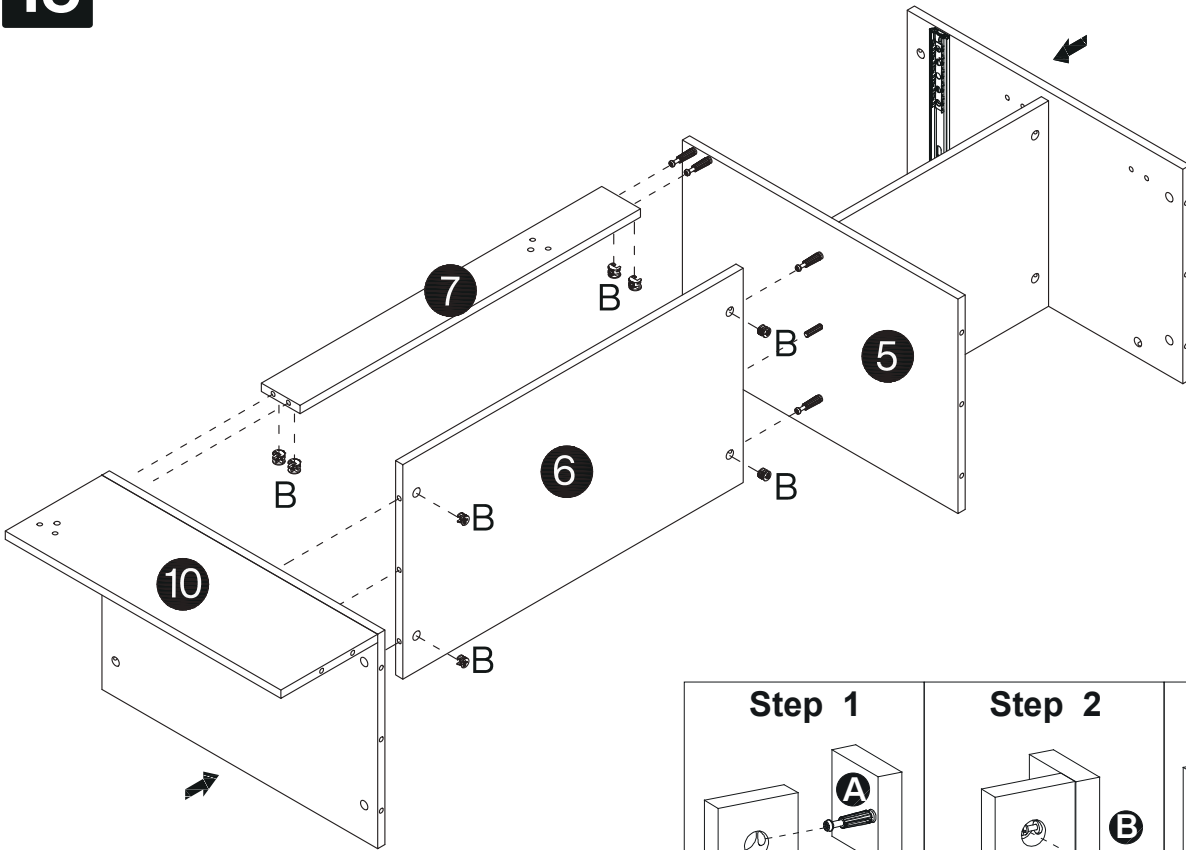

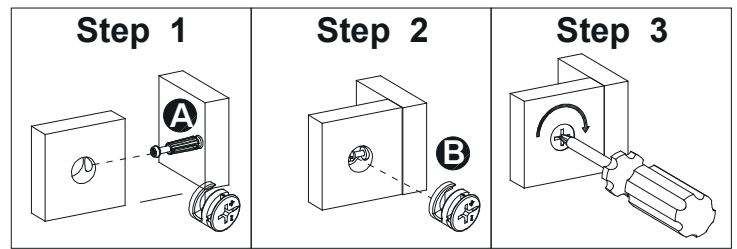

B

Ø15x12mm
8pcs

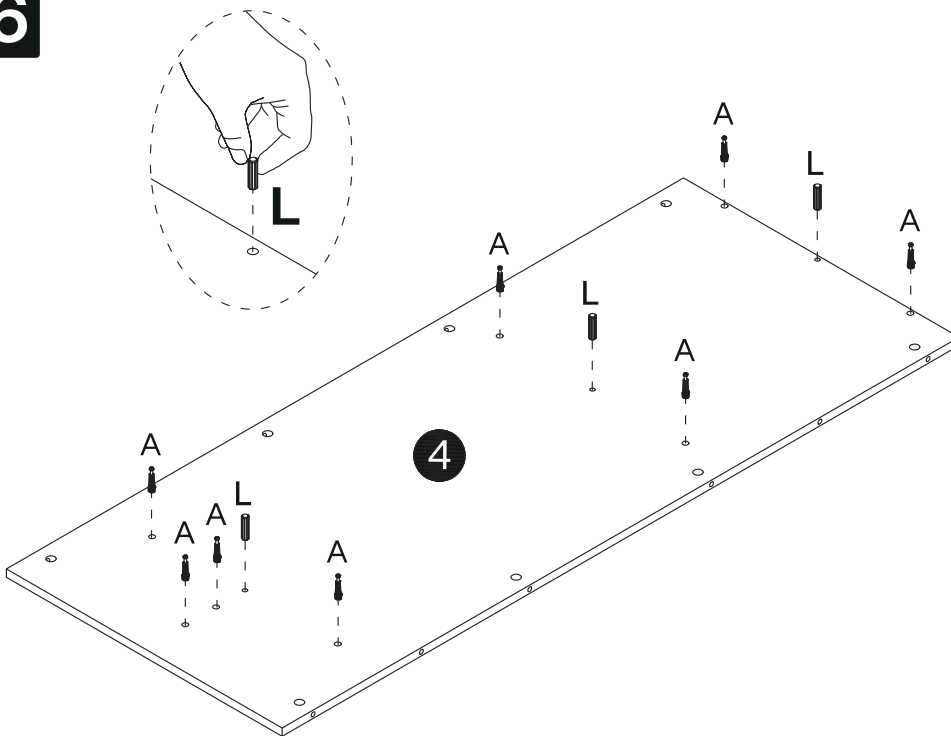

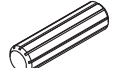
16

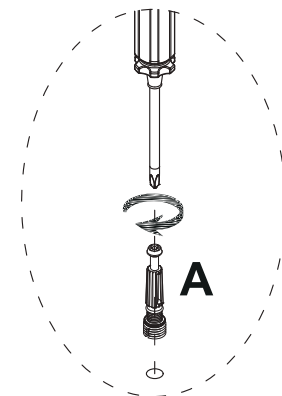

L	A
	
Ø8x30mm	M6x40mm
3pcs	8pcs



17

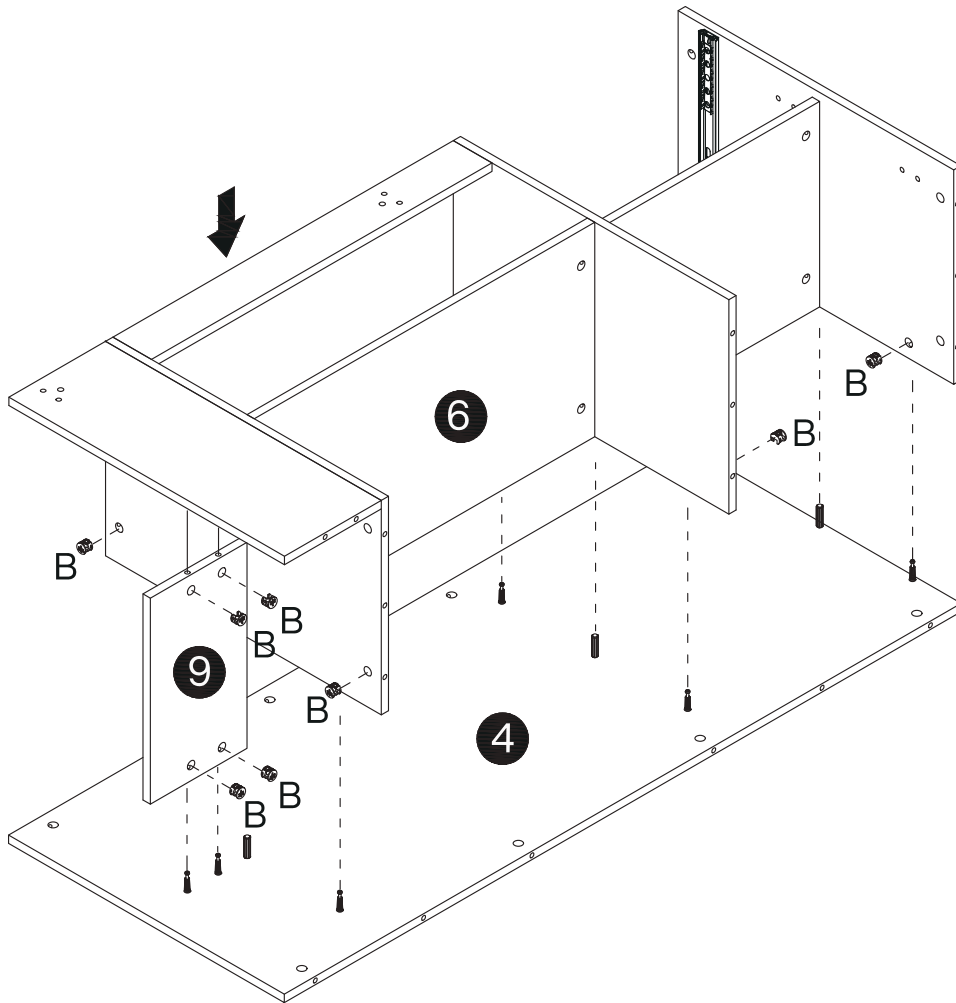

B

Ø15x12mm
10pcs

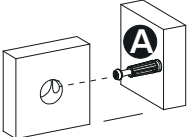
Step 1

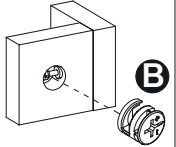

Step 2



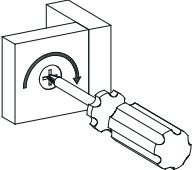

Step 3

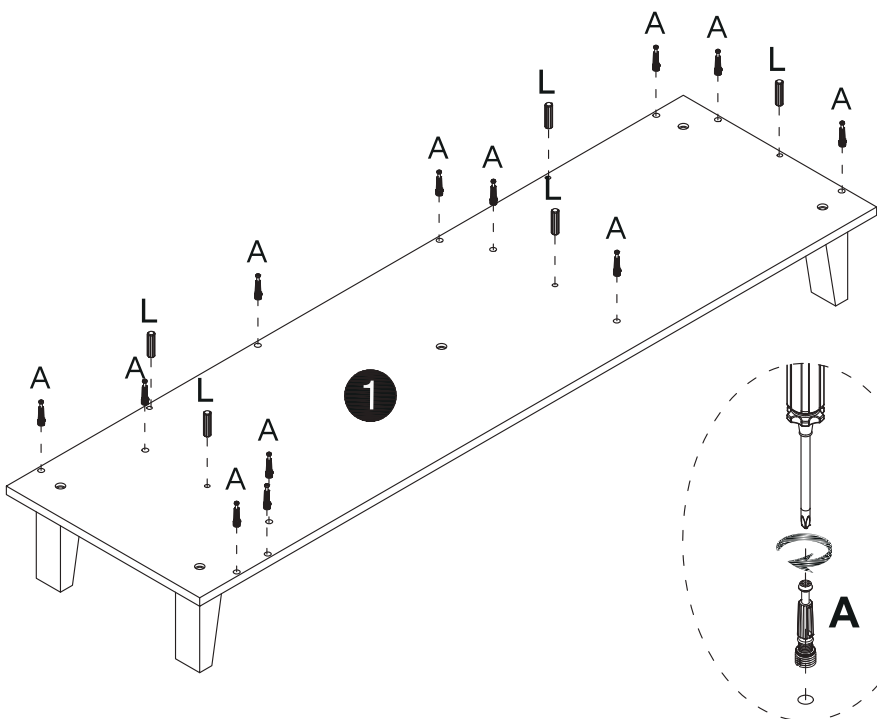

18



L	A
	
Ø8x30mm	M6x40mm
5pcs	12pcs

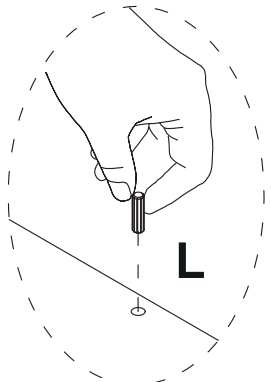
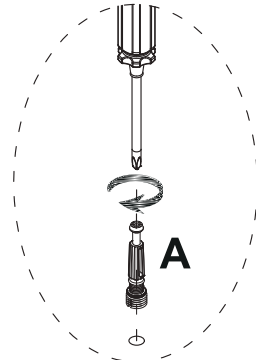

19

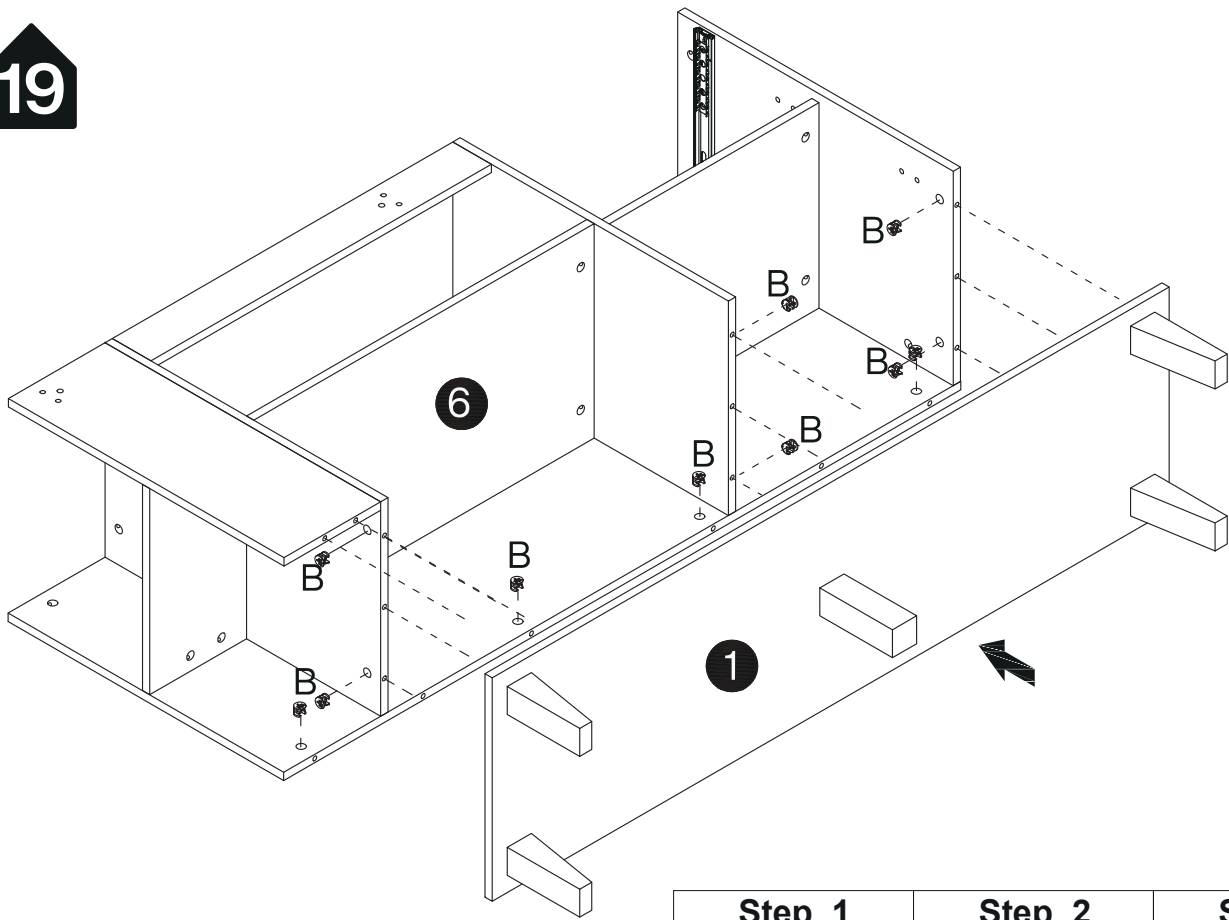

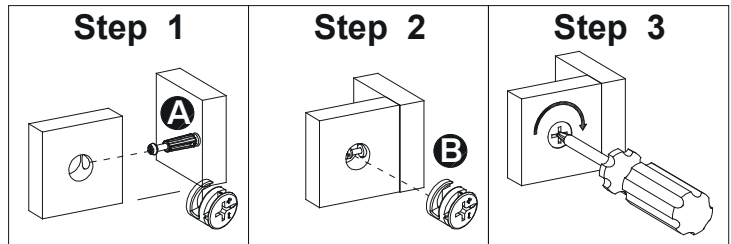

B

Ø15x12mm
12 pcs

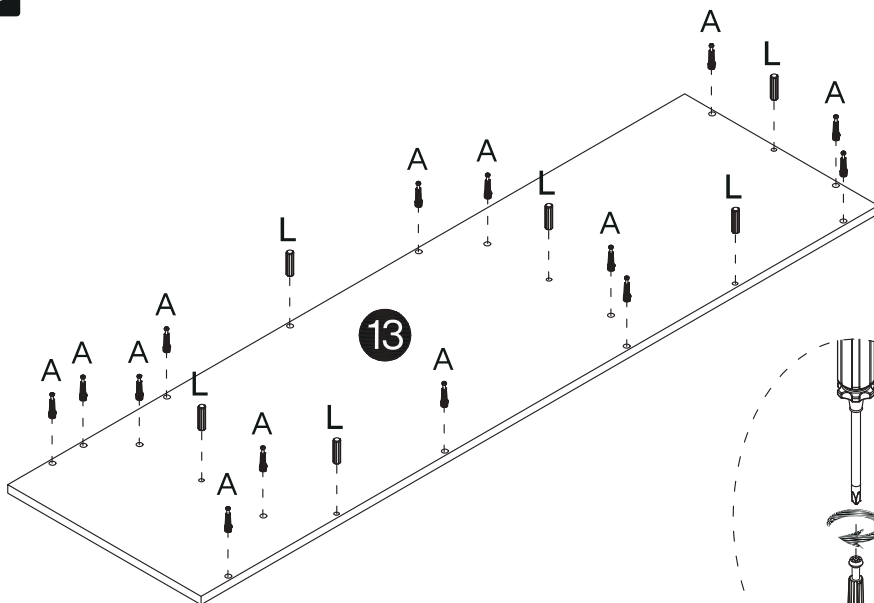

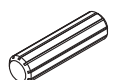
20

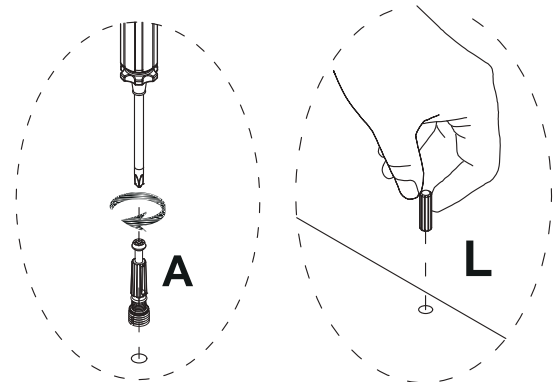

L	A
	
Ø8x30mm	M6x40mm
6 pcs	14 pcs



21

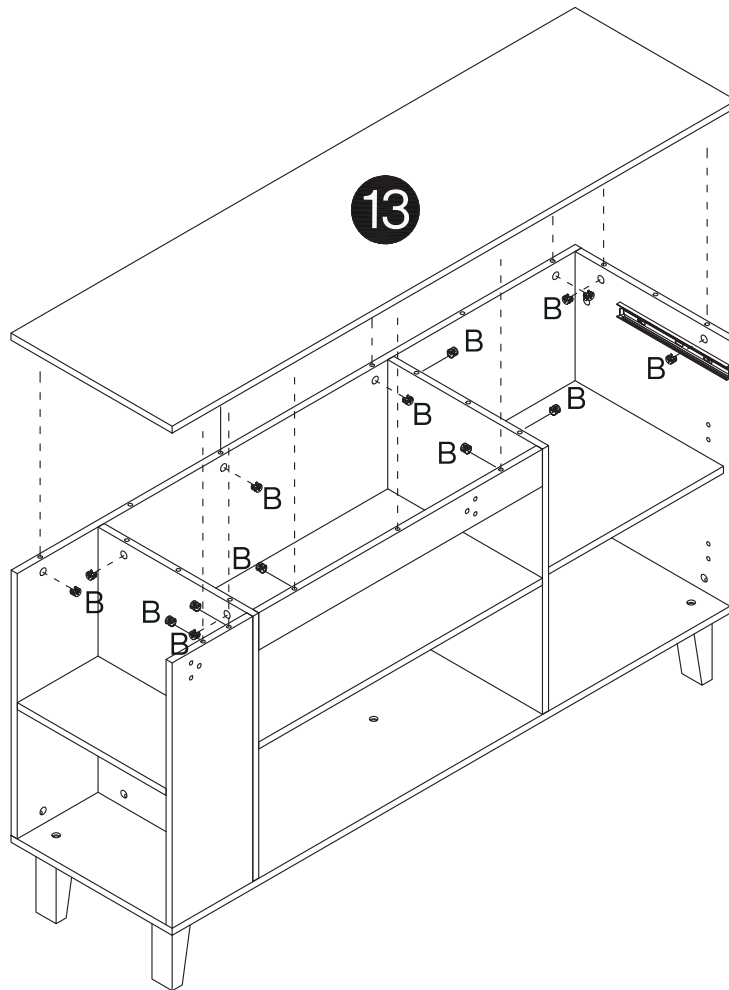
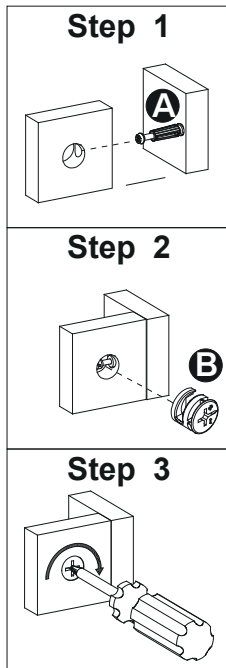

B

Ø15x12mm
14 pcs

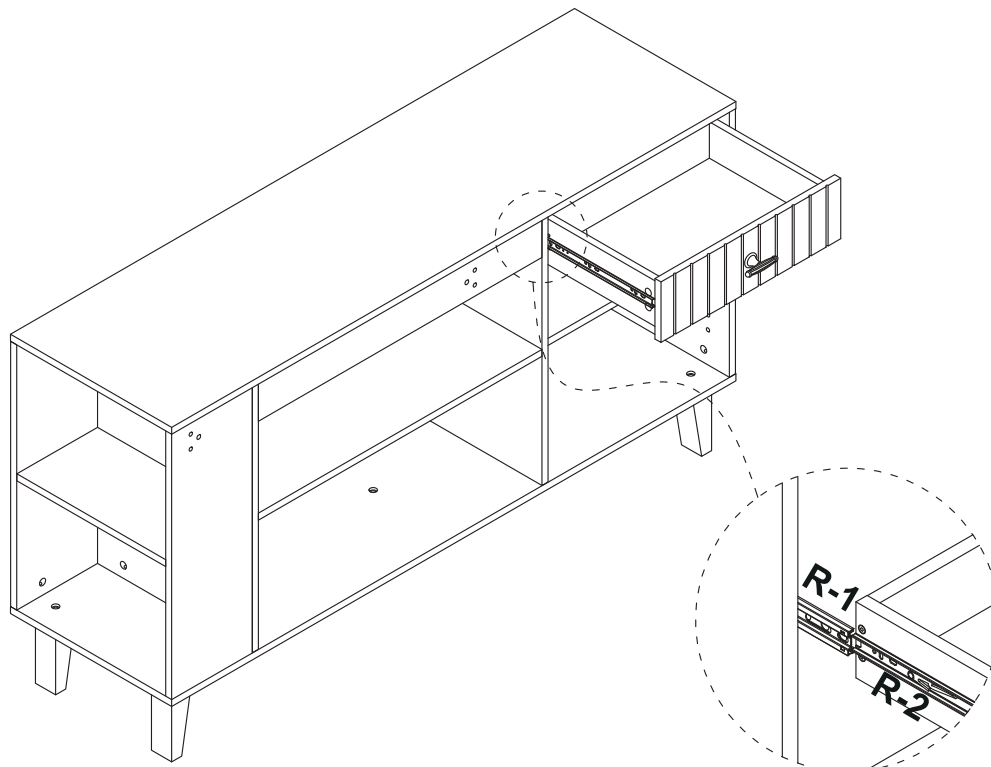



22

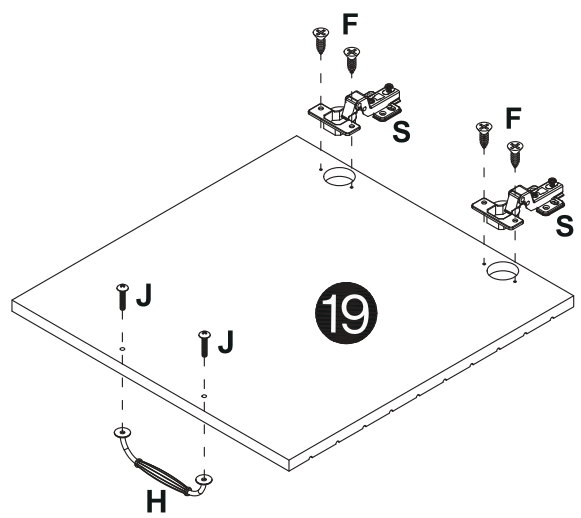

Before installation, slide the inner iron pieces of #R-1 to the outermost side. Then align it with #R-2 and gently push it inward to complete the slide installation.

23



F	S
 Ø3.5x14mm	
4 pcs	2 pcs
J	H
	
2 pcs	1 pc

24

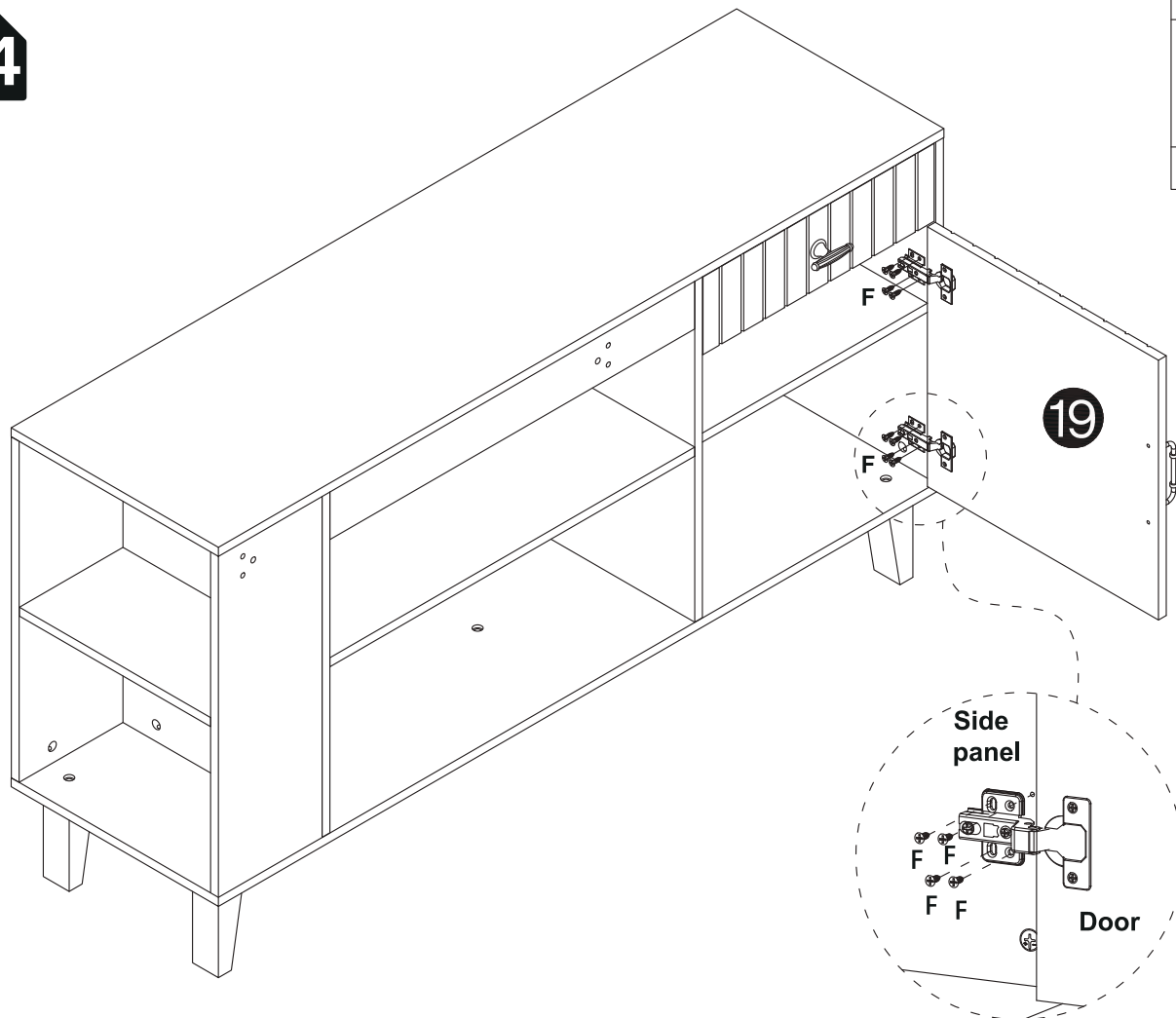

F
 Ø3.5x14mm
8 pcs

To prevent the door hinge from falling off, please install 4 screws P-20

Step 1

Open the door.

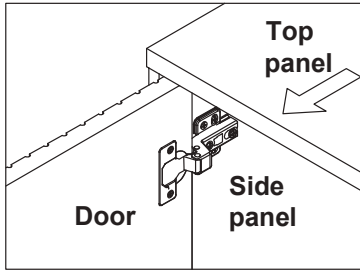

ADJUST YOUR DOORS TO MAKE THE GAPS MORE EVEN (OPTIONAL).

Step 2

Adjust the door panel to be flush with side panel and top panel edge.

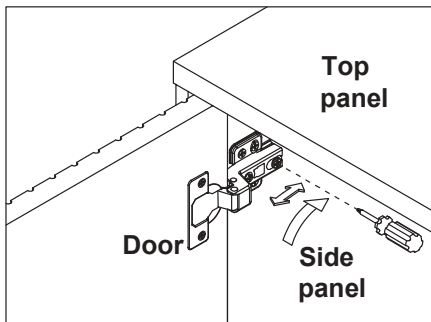

Loosen the screw indicated a little, adjust the hinge to the right position (see step 2a & 2b), then tighten the screw.

Step 2a MOVE DOOR OUT

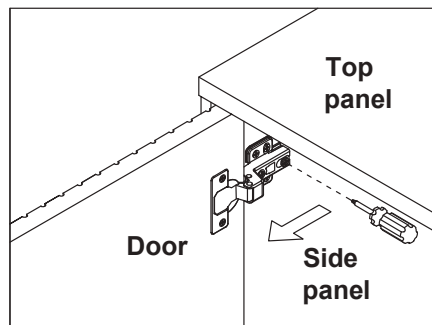
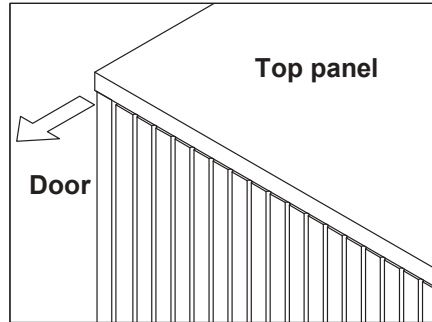

Pull the hinge forward a little.

Step 2b MOVE DOOR IN

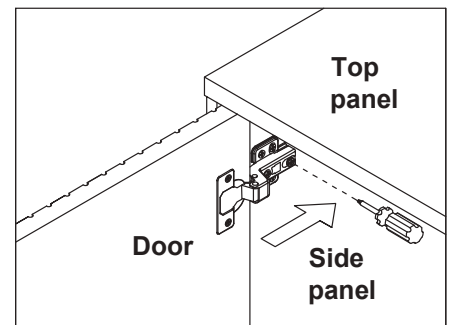
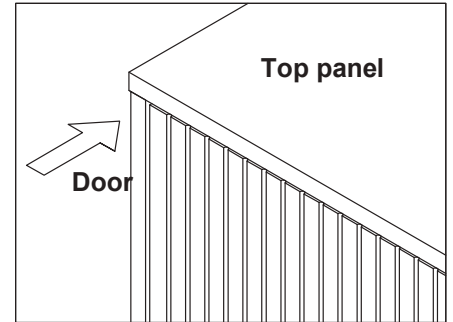

Push the hinge back a little.

Step 3

Adjust the gap between the door panel and the side panel.

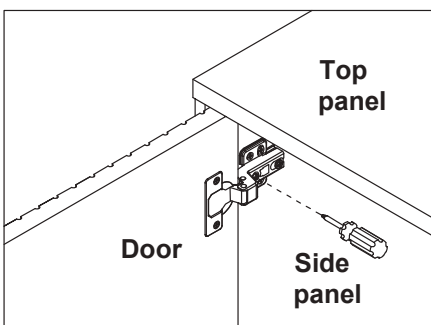

Loosen or tighten the screw indicated a little to adjust the gap between the door panels, adjust the hinge to the right position (see step 3a & 3b).

Step 3a MOVE DOOR LEFT

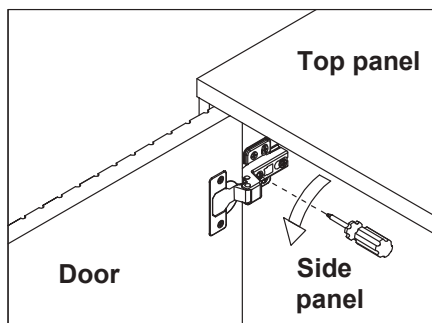
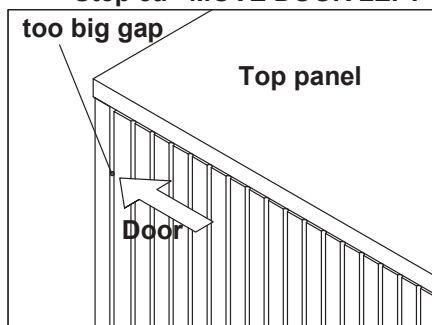

Turn the screw clockwise a little as shown to make the gap smaller

Step 3b MOVE DOOR RIGHT

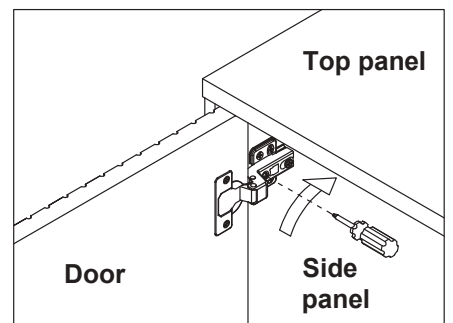
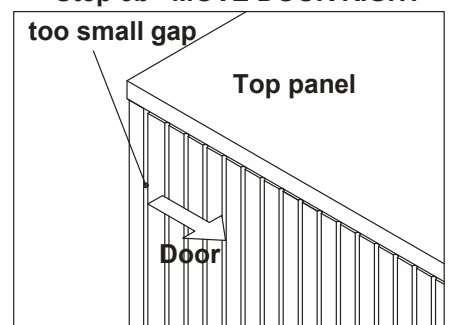

Turn the screw counterclockwise a little as shown to make the gap bigger

25

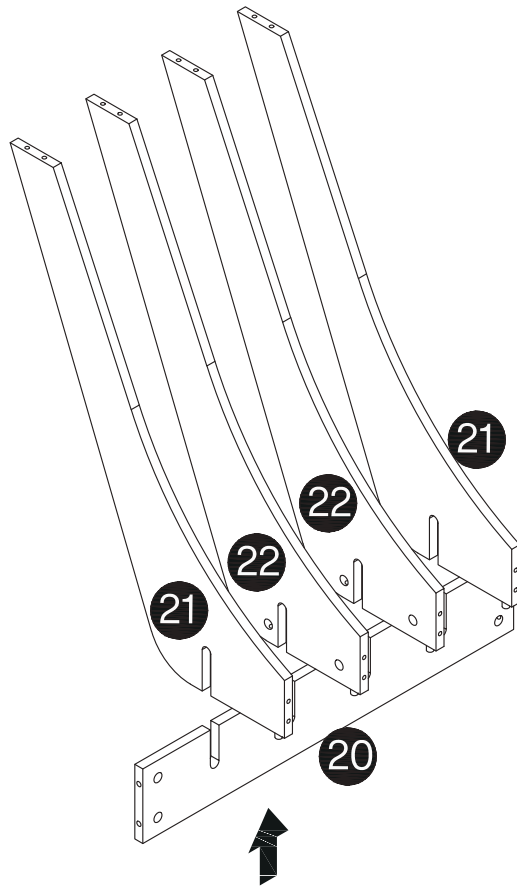

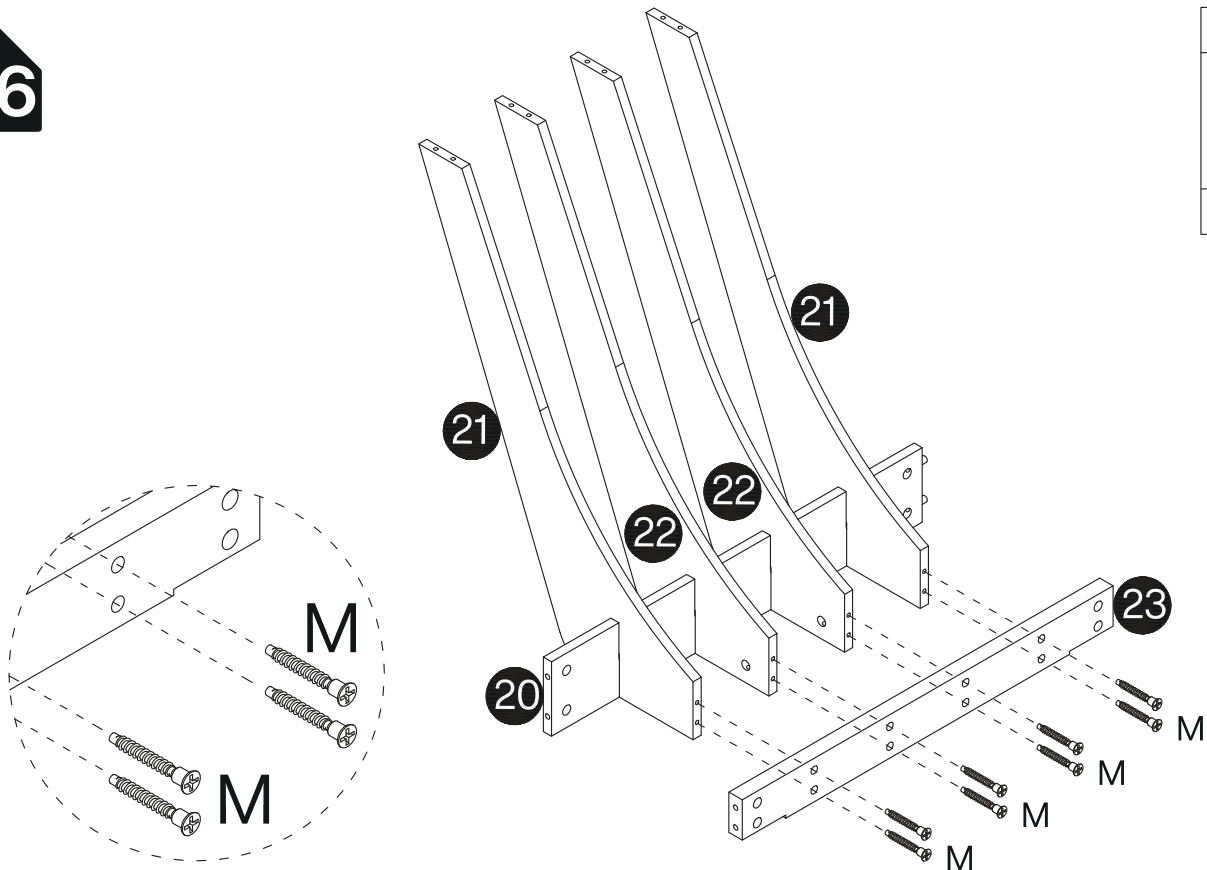

26

M

M7x38mm
8pcs

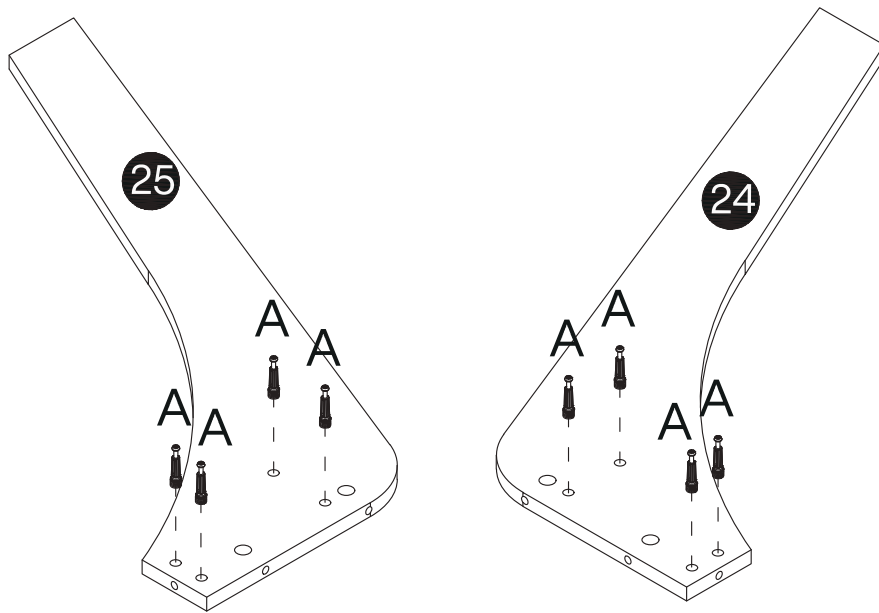



27

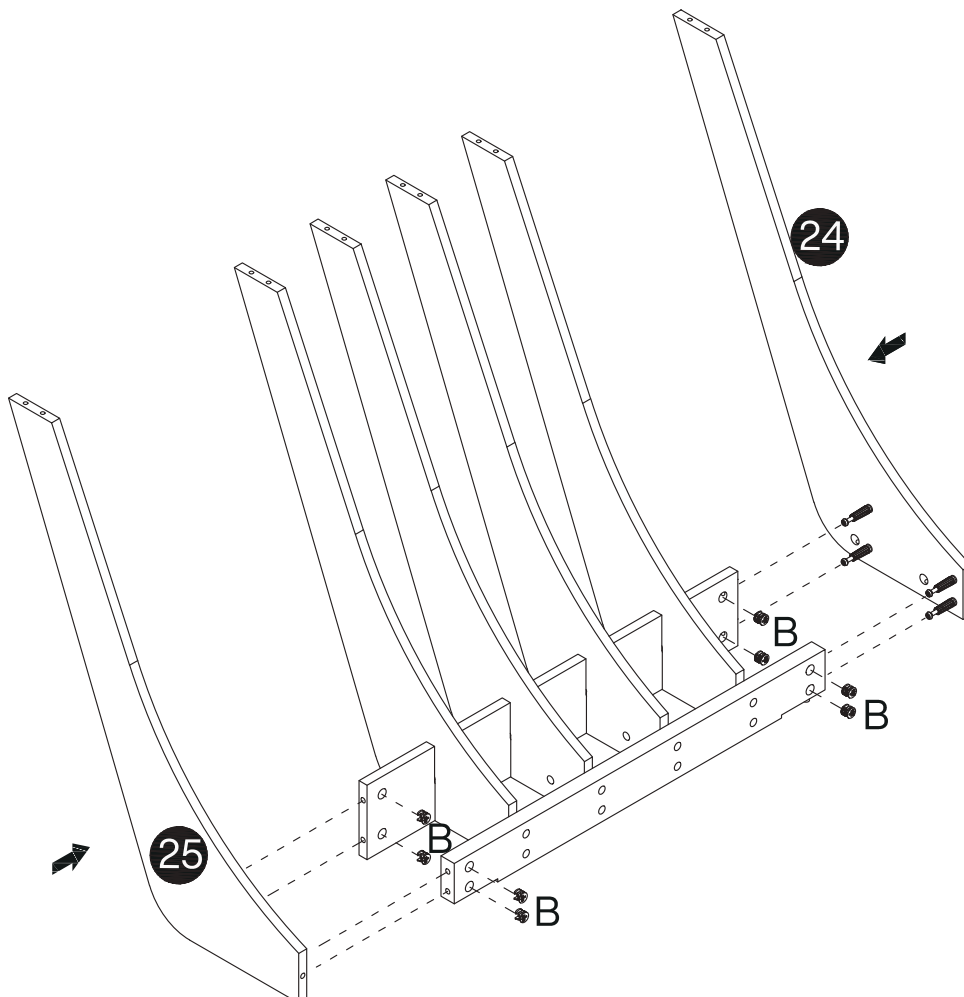

A

M6x40mm
8pcs

28

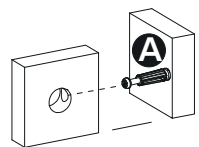

B

Ø15x12mm
8pcs

Step 1

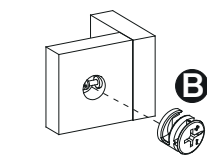

Step 2



Step 3

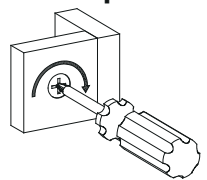

29

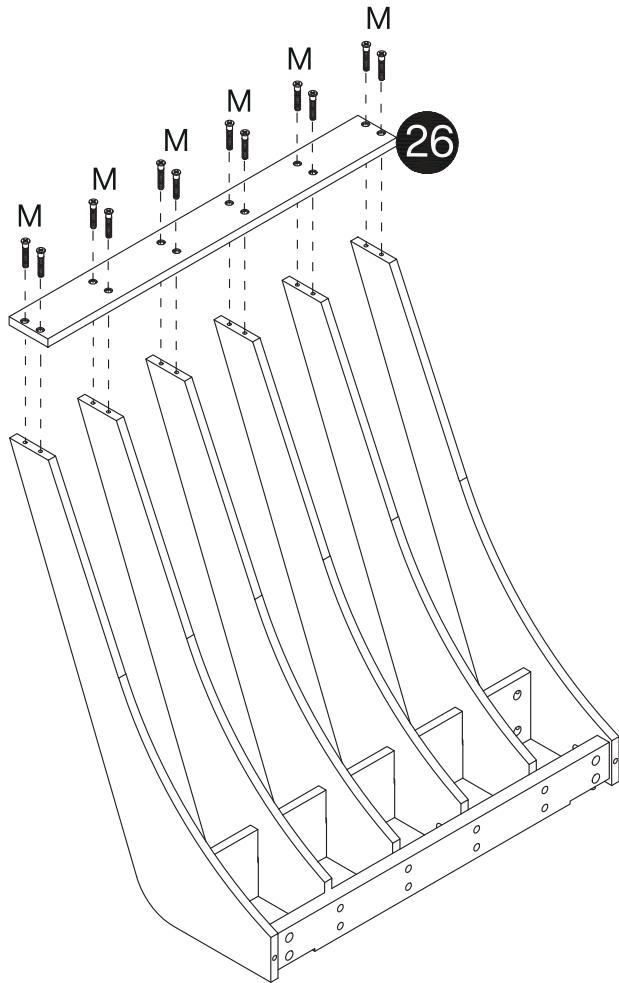

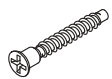
M

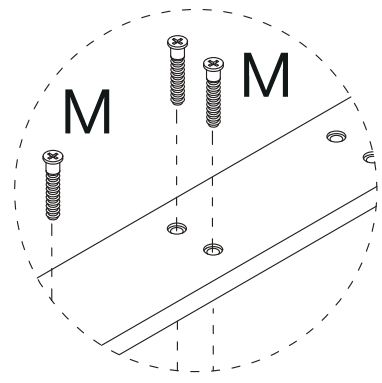
M7x38mm
12pcs

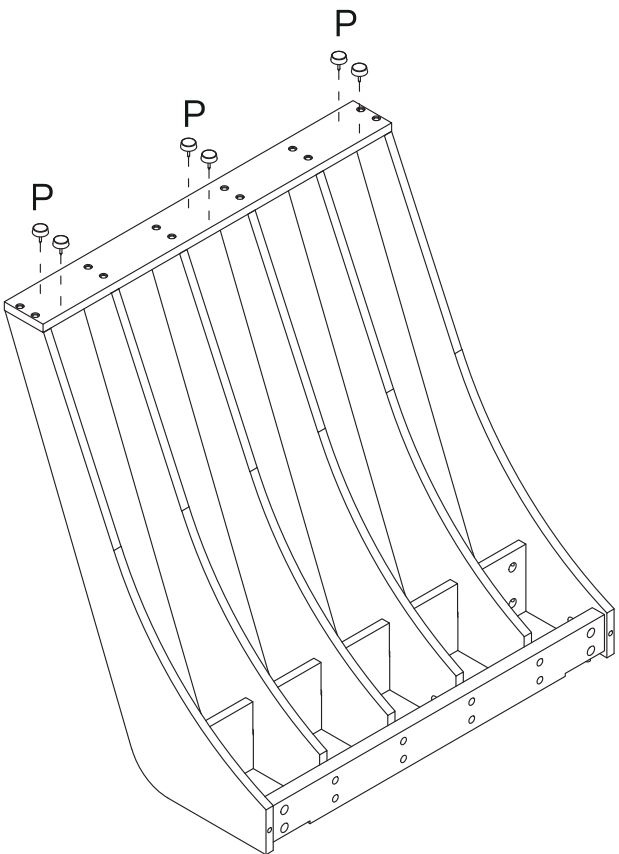

30



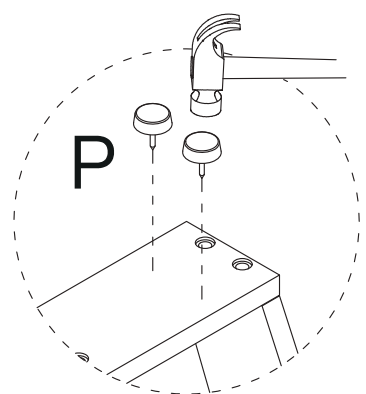

P

6pcs

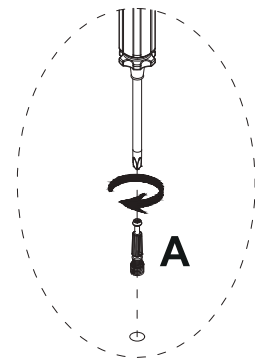
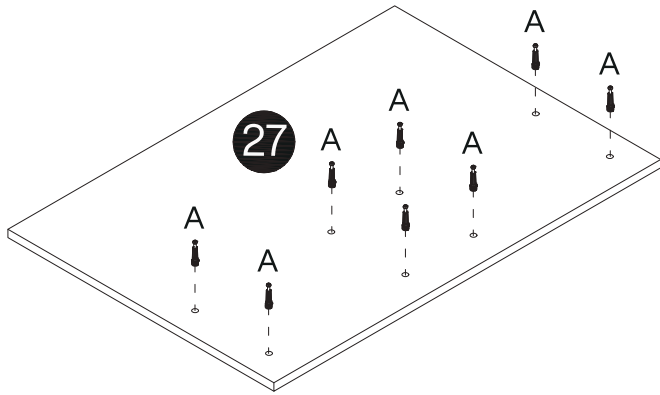

⚠ Caution! Tap lightly

31



A

M6x40mm
8pcs

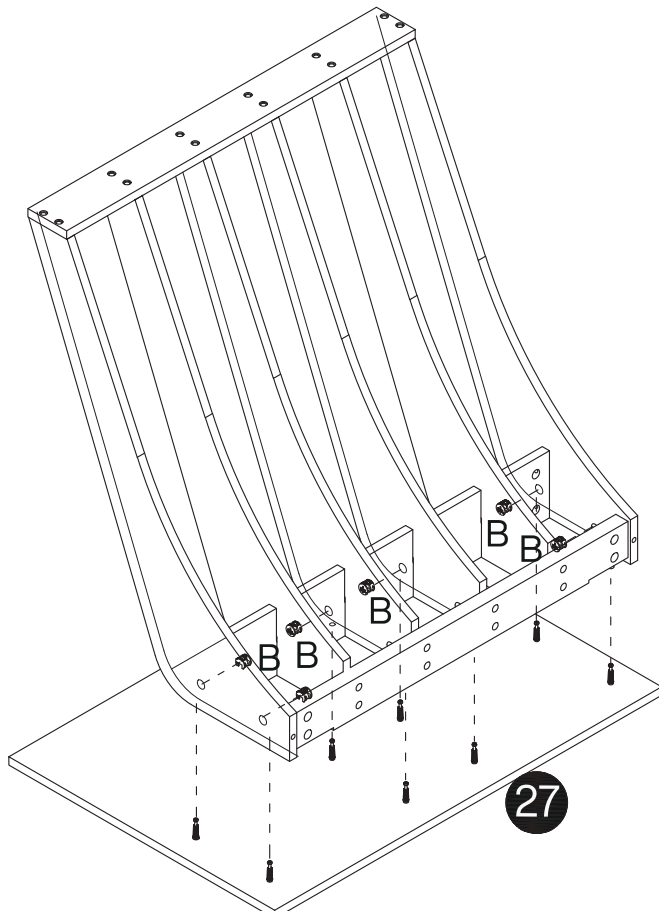
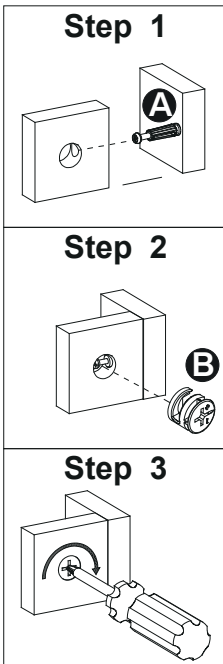
32

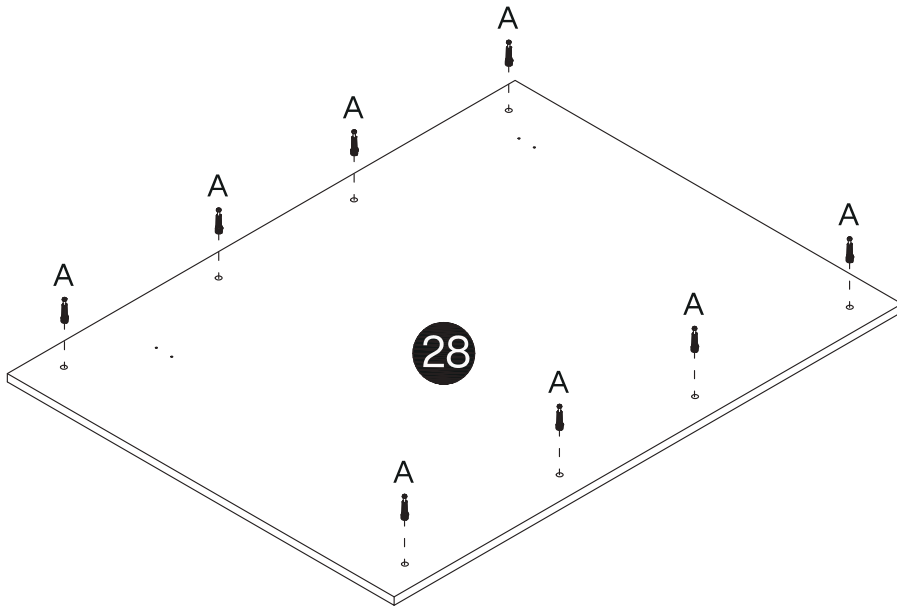

B

Ø15x12mm
8pcs

33

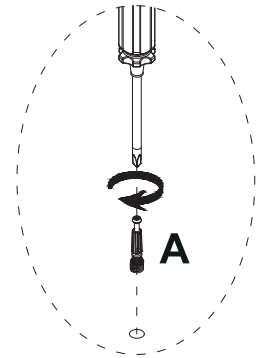

A

M6x40mm
8pcs



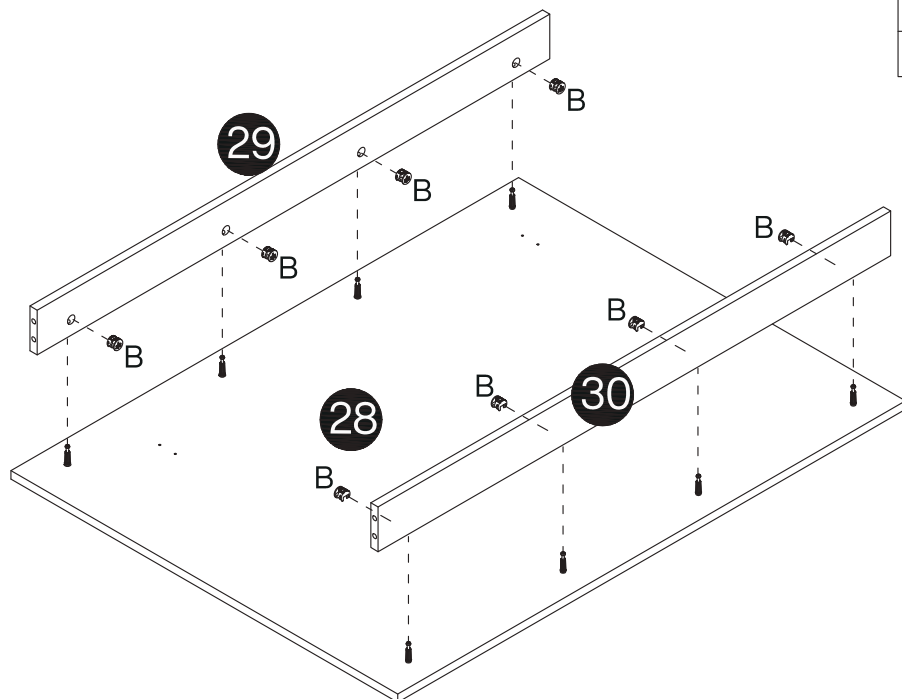
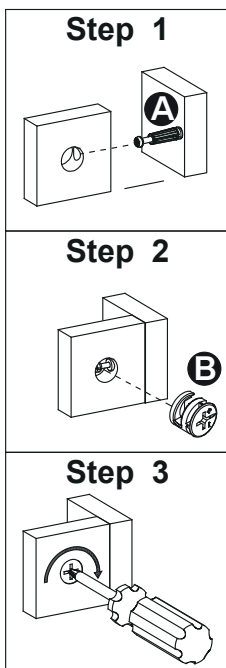

34

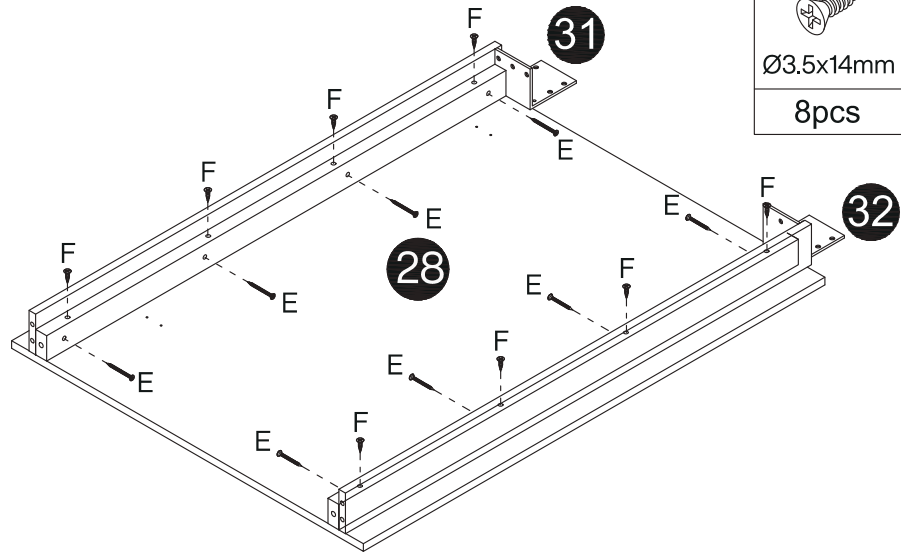
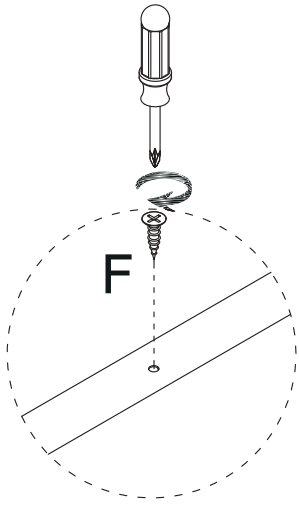

B

Ø15x12mm
8pcs



35

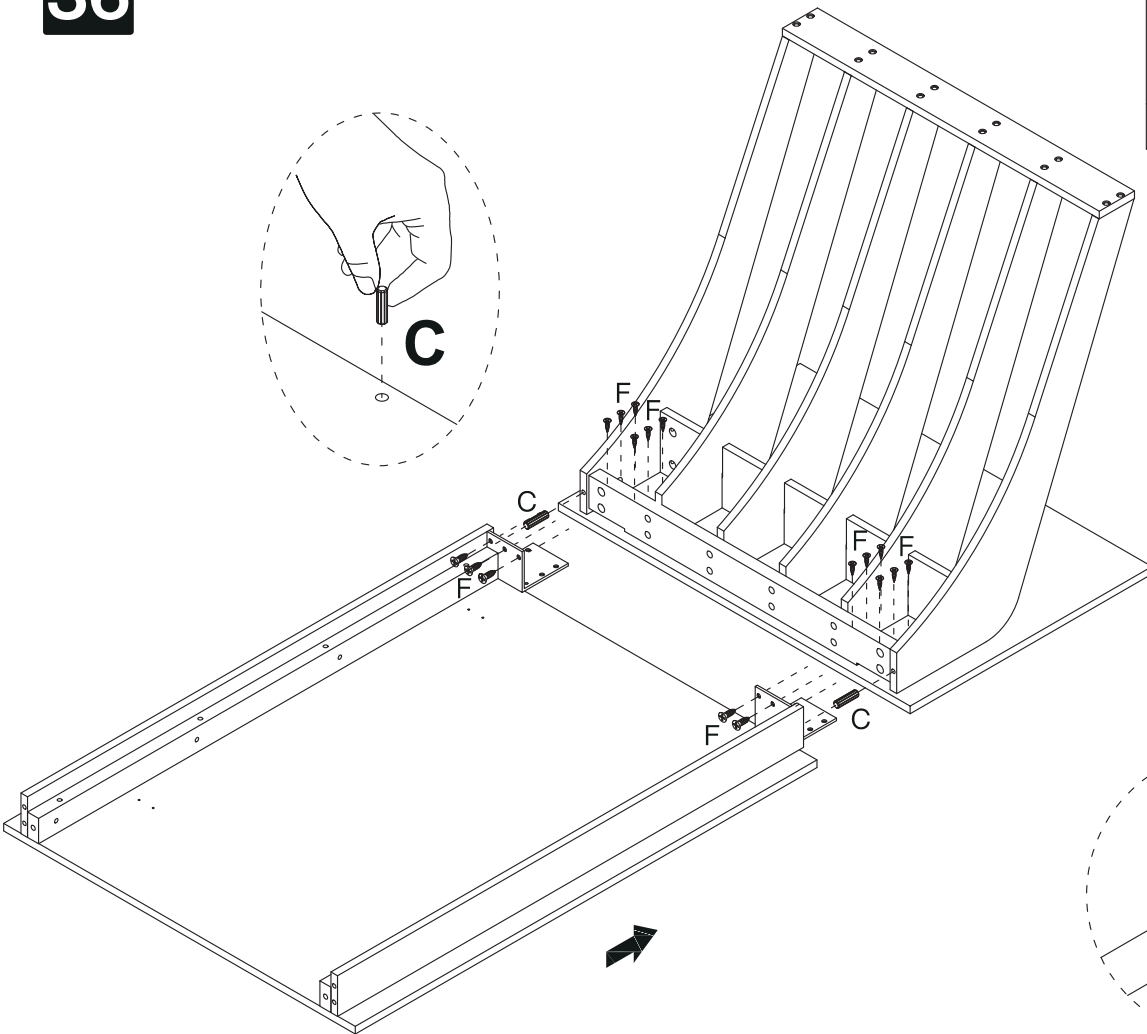
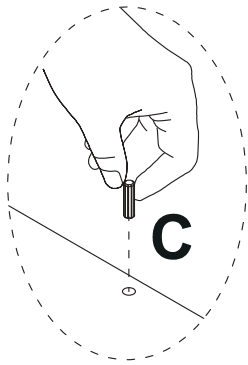

F	E
	
Ø3.5x14mm	Ø3.5x35mm
8pcs	8pcs

36



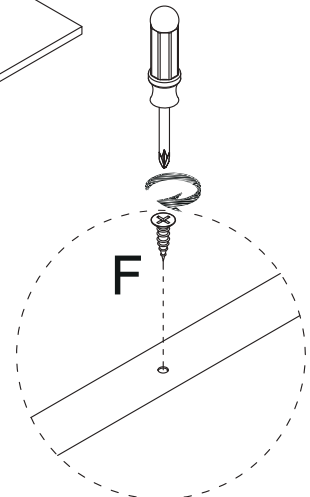

C	F
	
Ø8x40mm	Ø3.5x14mm
2pcs	18pcs



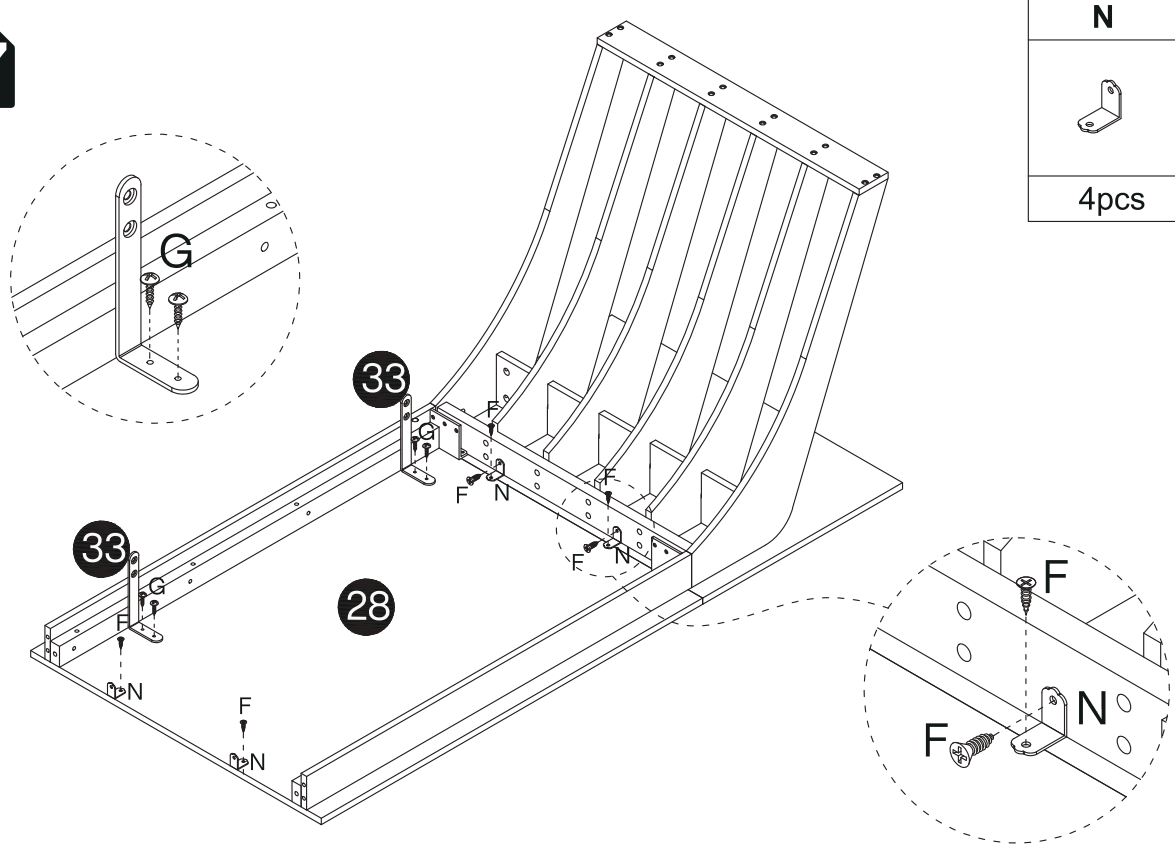

37

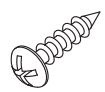

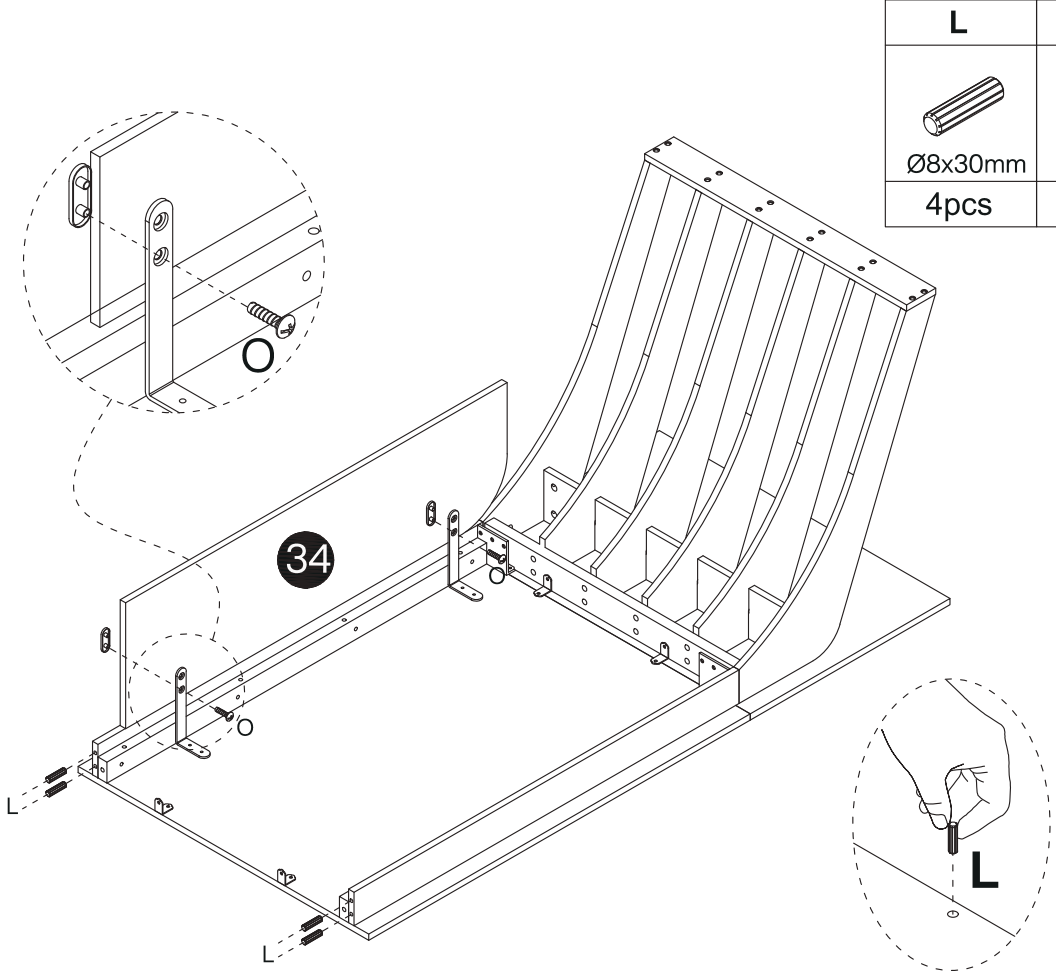

N	F
	
4pcs	6pcs
	G
	
	4pcs

38

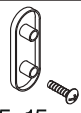

L	O
	
4pcs	2pcs

39

K	F
	
Ø8x30mm	Ø3.5x14mm
2pcs	2pcs

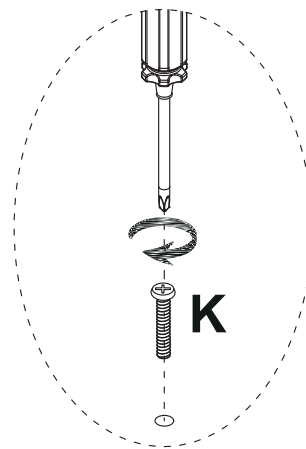
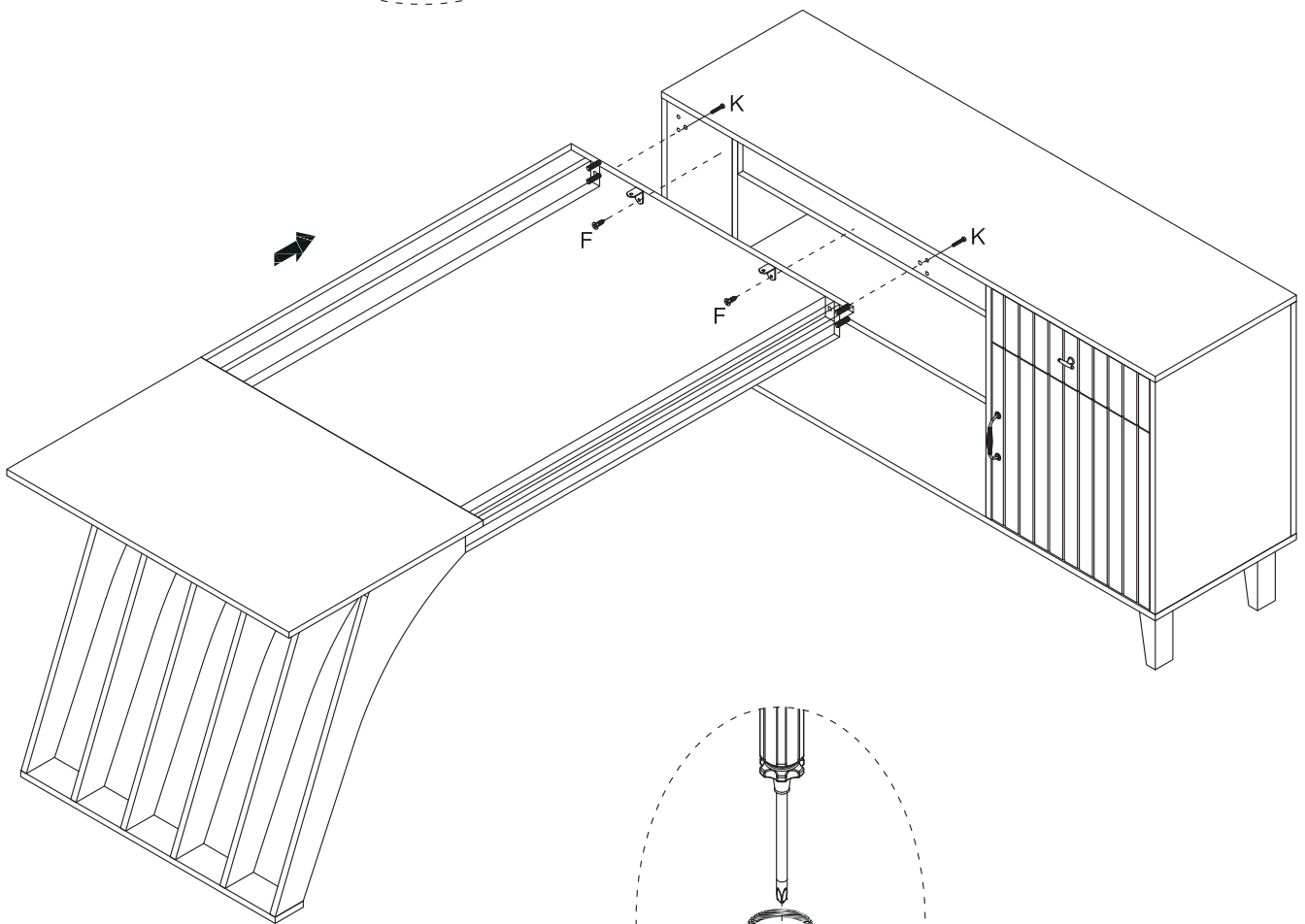
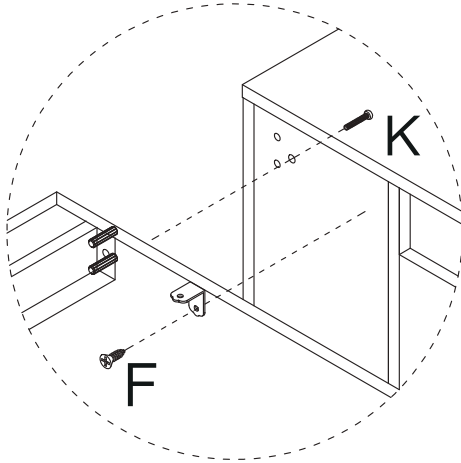

Thank you for your support!

