







# ASSEMBLY INSTRUCTIONS

## HARDWARE LIST

NO.	SKETCH	DESCRIPTION	QTY
A		Bolt(1/4"x7/8")	4 PCS
B		Washer(1/4")	4 PCS
C		Spring washer(1/4")	4 PCS
D		Allen wrench(4mm)	1 PC

## PARTS LIST

NO.	SKETCH	DESCRIPTION	QTY
1		Seat	1 PC
2		Metal Base	1 PC

### Step 1

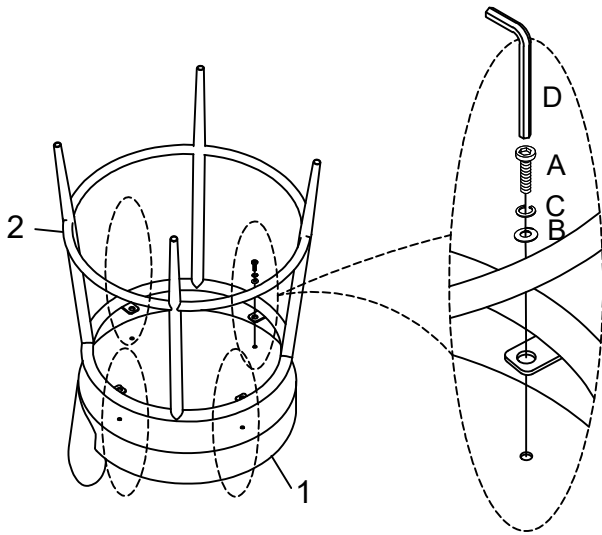

### Assembly Instructions:

To ensure installation stability, raise the Seat (1) to backrest level using supports (like books or cardboard boxes) to prevent tipping. Align the screw holes of the seat and base (backrest facing back), then sequentially mount gaskets (B) and spring pads (C) onto bolts (A). Insert these diagonally and tighten with Allen wrench (D).

### Step2

Rotate the base and adjust the height with four legs until the seat is stable and does not shake. Gently press the four corners to ensure a firm contact.

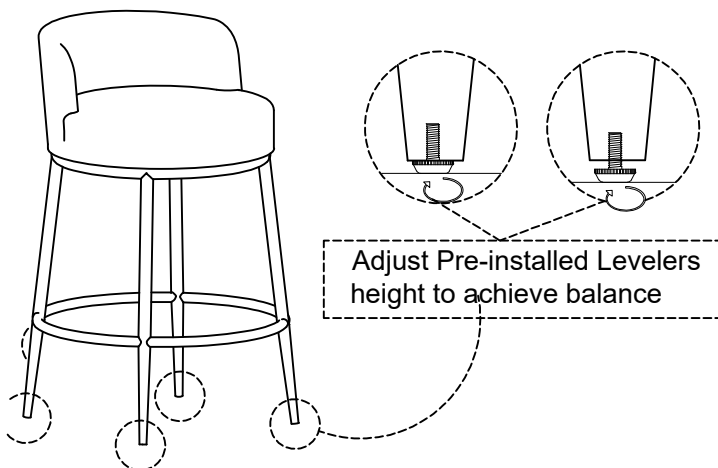

### Step 3

Check that all bolts are tightened and the seats are stable without shaking.

