

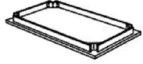





# ASSEMBLY INSTRUCTION

COFFEE TABLE		
<b>(Box 1)</b> BOX OF TABLE		
No	ITEM	Qty
A	Table 	1 pc
B	Leg 	4 pcs
<b>(Box 1)</b> HARDWARE LIST		
No	ITEM	Qty
1	ALLEN KEY m5x65mm Blk 	1 pc
2	JCBB Bolt m8x60mm Blk 	8 pcs
3	Flat Washer 5/16"IDx22mmOD Blk 	8 pcs
4	Spring Washer 5/16" Blk 	8 pcs
<b>"THE HARDWARE IS LOCATED IN THE PACKING ITEMS"</b>		

**STEP 1 : Attach Table Top (A) at soft surface**

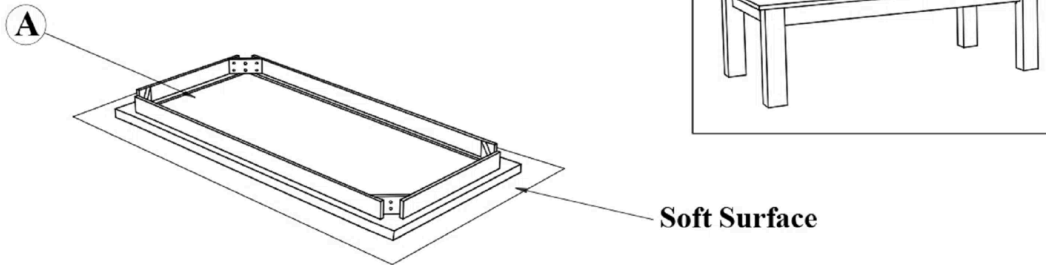

**Soft Surface**

**STEP 2 : Attach Leg Post (B) at Table Top (A) with Flat Washer (3), Spring Washer (4) and JCBB Bolt (2) and tighten with Allen Key (1).**

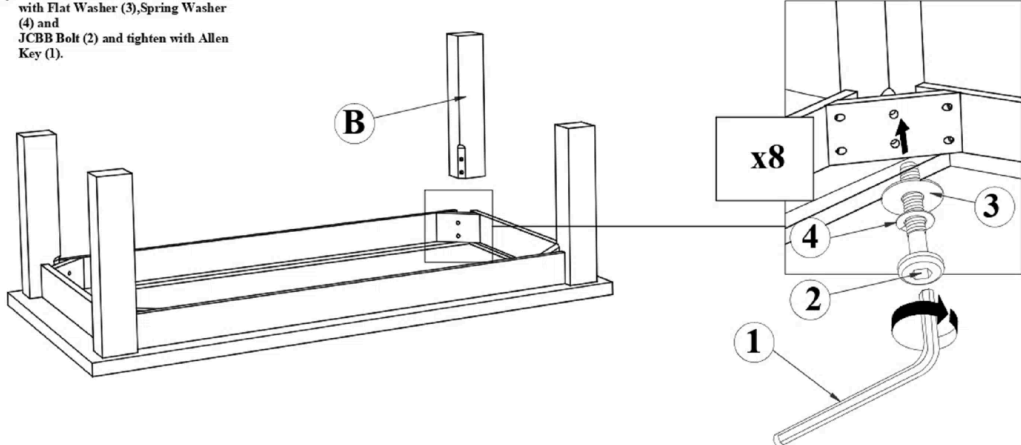

NOTE : MUST TIGHTEN SCREWS PERIODICALLY WITH USE SCREW WILL BECOME LOOSE CHECK TIGHTNESS OF ALL SCREW EVERY 6-8 WEEKS.