

## Description: RIVERDALE DINING TABLE TOP RIVERDALE TABLE BASE

**Product size : 36" x 72"x 84" x 96" W/Two 12" Leaves**

Your furniture purchase is an investment. Here are a few tips to maximize the lifetime of your furniture with a minimum amount of effort. Properly caring for your furniture can help ensure that it looks great year after year.

**Wood Furniture Maintenance:**

- Always dust, wipe, and clean *with* the grain of the wood.
- Dust with a soft cloth. Dust will scratch the furniture surface if not removed properly.
- Use the same type of polish consistently as interchanging oil-based and wax-based polishes will cause a build-up and result in a foggy or cloudy appearance.
- If a polished surface becomes foggy, rub it with a cloth dipped in a solution of one tablespoon vinegar to one quart of water. Rub softly with the grain until the surface is completely dry.
- Soap and water are not advisable for wood surfaces. Water can penetrate the finish and raise the grain on wood, causing damage.
- Remember to change dusting cloths frequently as dirty cloths may scratch your furniture's surface.

**The Enemies of Wood:**

- Moisture is wood's worst enemy. Liquid spills should be gently wiped up immediately. Coasters should be used under all beverages.
- Do not allow rubber or vinyl materials to lie on the furniture. Chemicals in rubber may leave a stain. Put a strip of felt or leather under accessories that have rubber or vinyl.
- Heat creates a chemical change in the furniture's finish, which results in a white spot. Use protective pads under hot dishes, appliances, etc.
- Sunlight's ultraviolet rays can damage the finish of furniture. Do not place furniture directly against a heater or radiator and do not place in the path of hot streams of air from central heating. This will cause extreme localized drying of the wood.

**High Gloss Resin Table Maintenance:**

- Resin tabletops have approximately 1/8" of a resin coat on the top face of the table, which will resist ice, water, wine, liquor, food, cleaning fluids, and warm or hot liquids; however, cups, glasses, etc. containing hot liquids should not be left on the table without a coaster for protection.
- Resin tabletops will scratch just the same as any other glossy surface and basic precautions should be taken.
- For lasting shine, the resin table should be waxed with a car wax that does not contain silicon. Maintaining this wax build-up will result in a high gloss shine.
- When wiping down the table, a soft, clean rag should be used. Do not use a heavy paper.

**Granite Top Maintenance:**

The surface of the granite on your table has been polished or sealed to create a generally non-porous surface. The stone has many natural characteristics including: veining, hairline cracks, and color variations - which make up the stone's beauty.

To maintain the beauty of your granite:

- Protect surfaces from scratching, staining and etching by:
  - \* Keeping them free of debris or sharp objects
  - \* Wiping up spills immediately
  - \* Avoiding contact with chemicals (particularly acid-based materials)
- Clean with pH neutral products or those especially formulated for use on stone.
- It is not recommended to use a water-based solvent for dark granite as it will remove the polish from the surface.
- After a period of use, apply a penetrating sealer to prevent contaminants from being absorbed into the stone.
- Remove stains with special absorbent poultices formulated for use on stone.
- Renew the surface on polished granite (granite with a high gloss surface ) by buffing with special stone polish , powder or cream .

Do not use granite polish on granite with a matte finish, which has been honed rather than polished. (Penetrating sealer may be used on both polished and honed granite.)

**Marble Top Maintenance:**







Marble may be stone, but it is porous stone and can stain easily. Treating marble surfaces the same as wood surfaces is a great rule of thumb.

- It is recommended to seal the tops on a regular basis (every 6 to 12 months). A good quality stone sealer can be purchased from any tiles/stone store or any homecare store and should be applied according to the manufacturer's recommendation.
- When sealed properly, marble tops can be used indoors and outdoors and can withstand any weather conditions except internal freezing. Snow or freezing rain will penetrate the table and cause cracks.

**Caring for the Fabric on Upholstered Furniture:**

- Frequent vacuuming of the entire upholstered area will prevent dust from settling into the fibers.
- Professional cleaning is always recommended for all upholstered pieces.
- Always pre-test a small area of fabric in an inconspicuous area when cleaning before proceeding.
- Do not use cleaning products containing brightening agents.

### VERY IMPORTANT!!

<p><b>NEVER</b> USE GLASS CLEANERS ON FINISHED SURFACES. AMMONIA WILL CHEMICALLY ATTACK THE FINISH.</p>	<p>DO NOT WRITE DIRECTLY ON SURFACE </p> <p style="text-align: center;"><b>PREVENT MARKING</b></p>	<p>DO NOT PLACE DIRECTLY IN SUNLIGHT </p> <p style="text-align: center;"><b>PREVENT FADING</b></p>	<p>DO NOT USE PLACEMATS WITH RUBBER BASES </p> <p style="text-align: center;"><b>PREVENT DISCOLORING</b></p>
<p><b>NEVER</b> ALLOW LIQUIDS OF ANY KIND TO LINGER ON SURFACES. ABSORPTION CAUSES THE WOOD TO WARP AND THE FINISH TO DE-LAMINATE.</p>	<p>DO NOT USE COMMERCIAL POLISHES AND WAXES </p> <p style="text-align: center;"><b>PREVENT YELLOWING</b></p>	<p>DO NOT PLACE HOT POTS, ETC. ON SURFACE </p> <p style="text-align: center;"><b>PREVENT DAMAGE TO FINISH!</b></p>	<p>REGULATE THE HUMIDITY CONDITIONS AT YOUR HOME </p> <p style="text-align: center;"><b>PREVENT SPLITTING</b></p>

# ASSEMBLY INSTRUCTIONS

**STEP 1:**

Attached Table Leg (D) to the Trestle Bar (E), insert Short Bolt (1), Lock Washer (2), Small Flat Washer (3) and tighten by Allen Key (4) as picture shown.

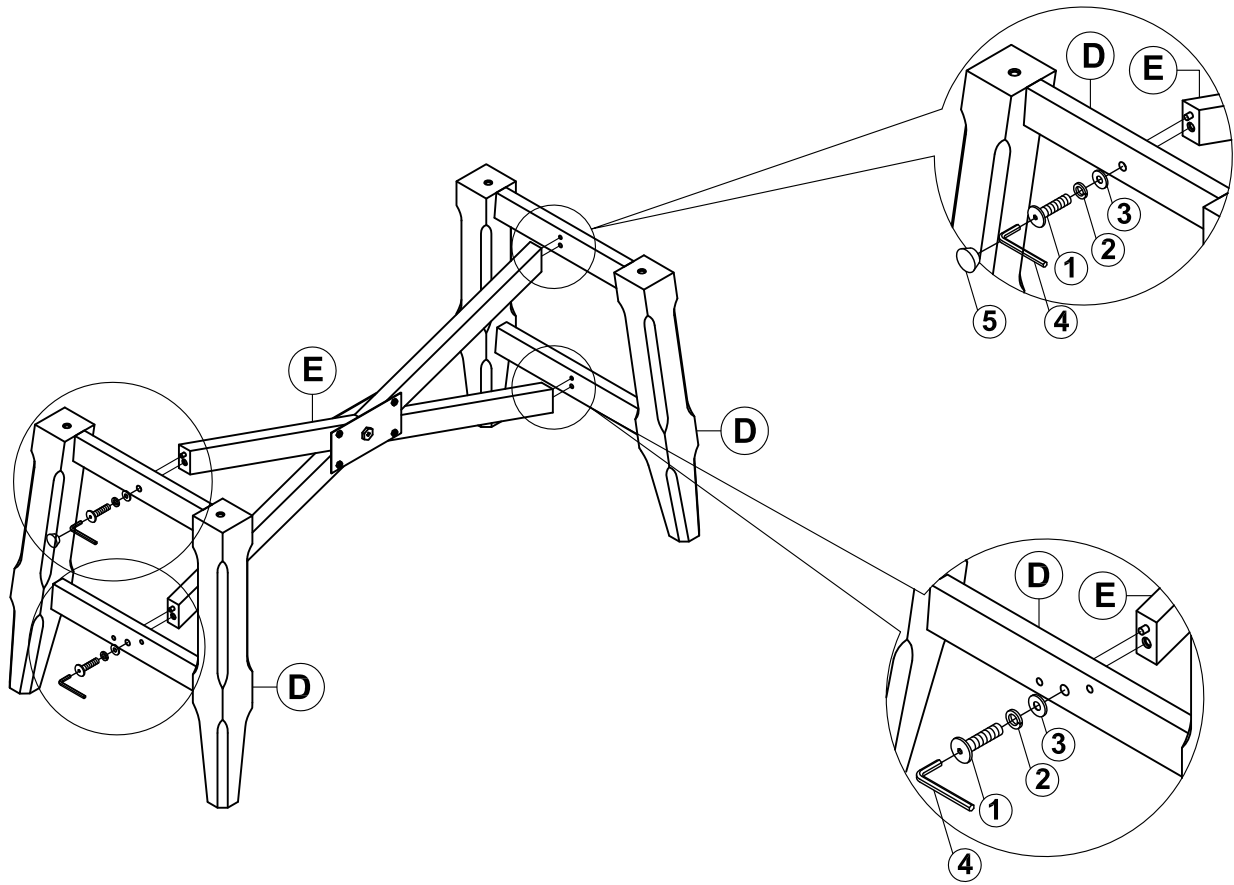

**STEP 2:**

Attached Metal Plate Small (9) to the Table Leg (D) insert Short Bolt (10) as picture shown.  
Attached Mounting Plate (C) to the Table Leg (D) insert Middle Bolt (6), Lock Washer (2), Large Flat Washer (7) and tighten by Allen Key (4) as picture shown.

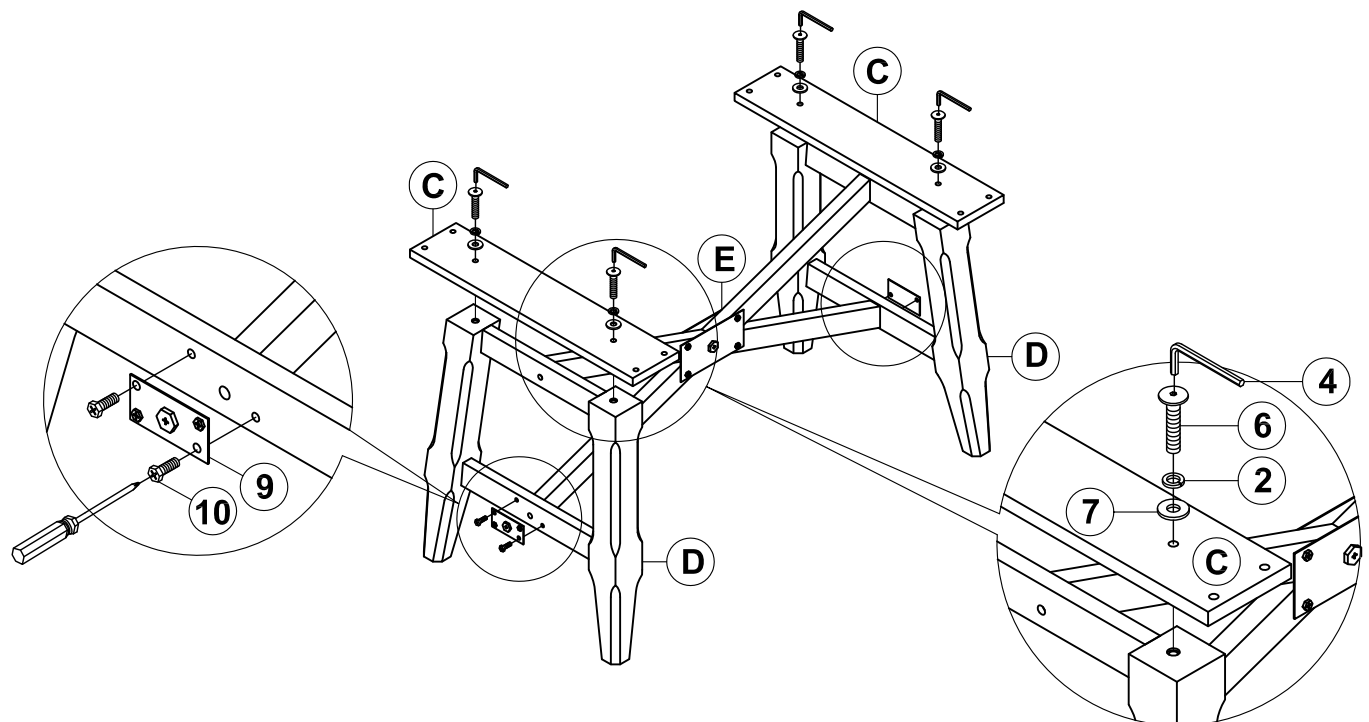

# ASSEMBLY INSTRUCTIONS

## STEP 3:

Turn the Table Top (A) upside down on a flat soft surface. Attached Table base assembly in Step 2 to Table Top (A). Insert Long Bolt (8), Lock Washer (2), Large Flat Washer (7) and tighten by Allen Key (4) as picture shown.

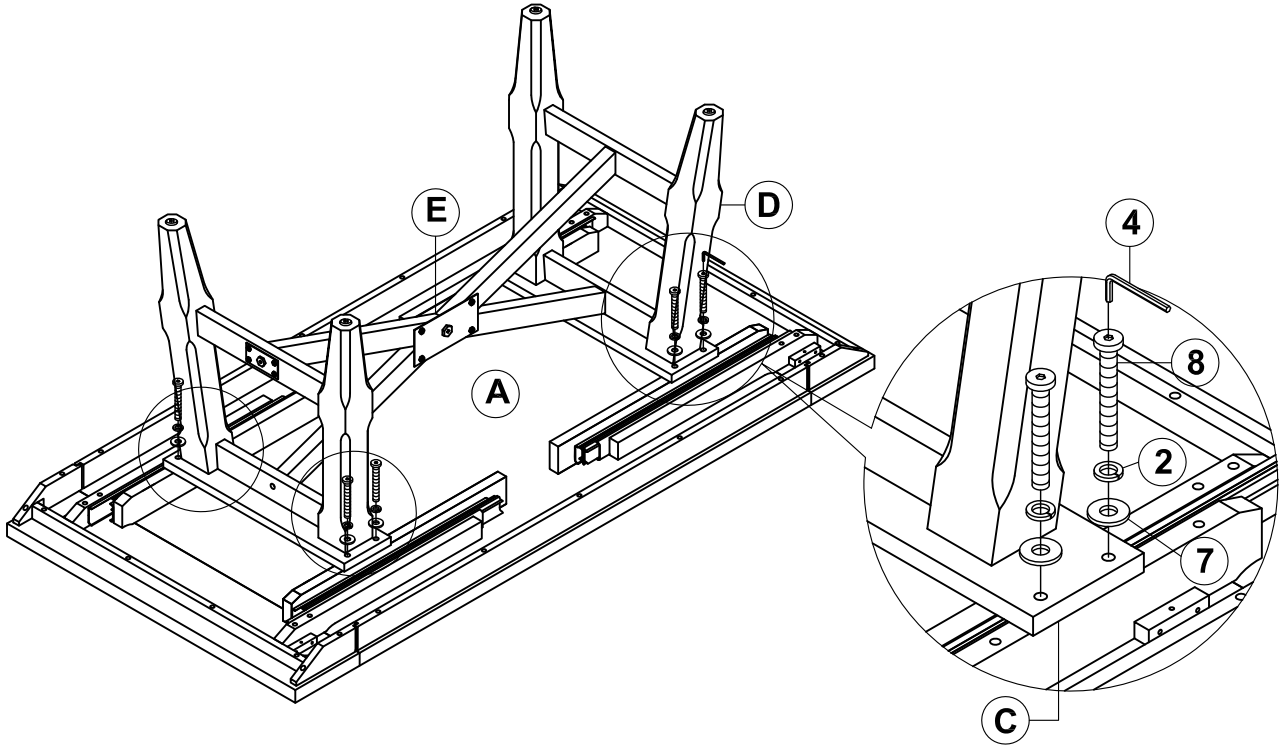

## STEP 4:

- Turn the table to upright position. Unlock the Latch underneath the Table Top (A). Pull from both ends of Table Top (A).

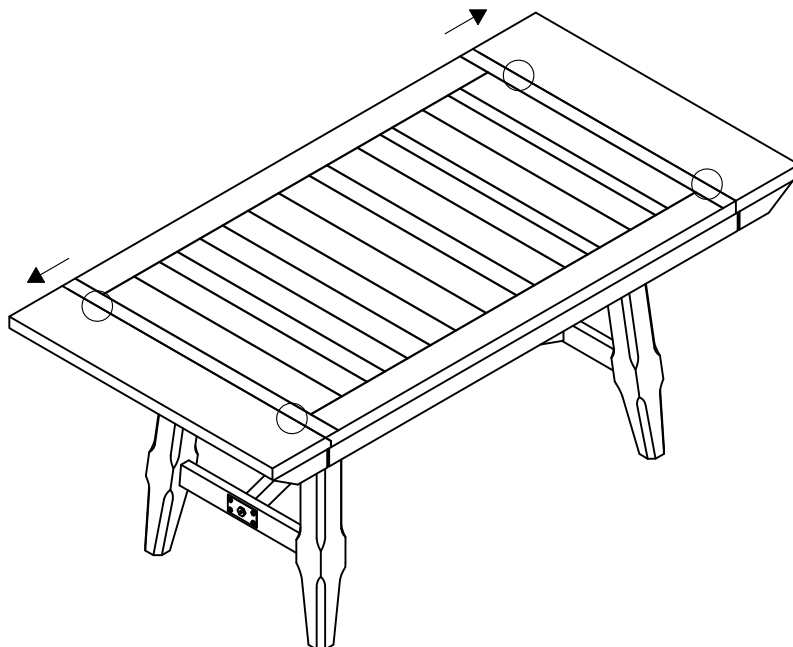

# ASSEMBLY INSTRUCTIONS

## STEP 5:



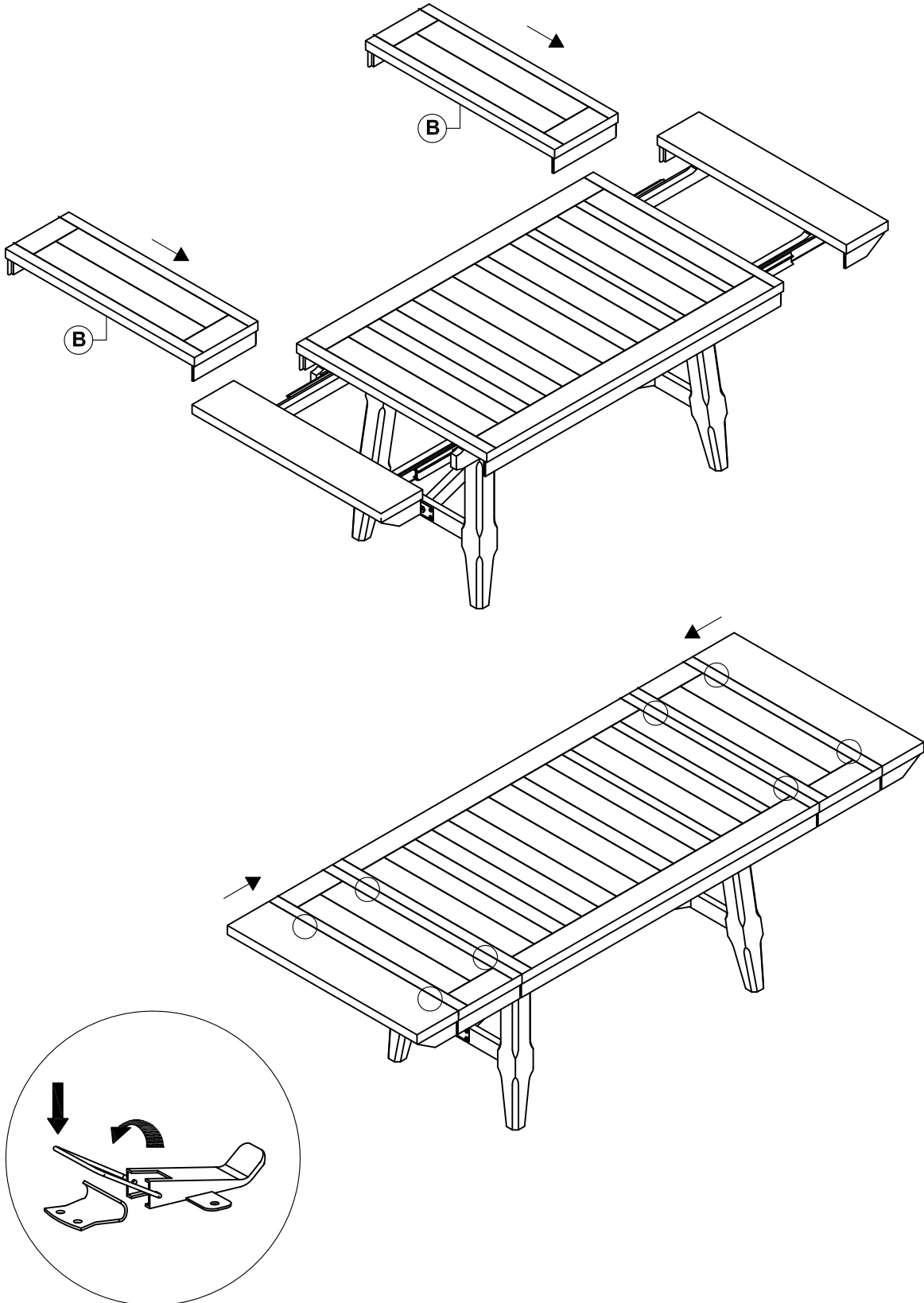



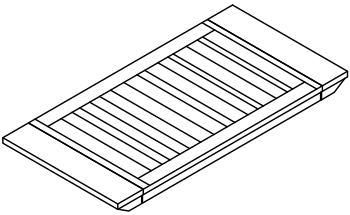
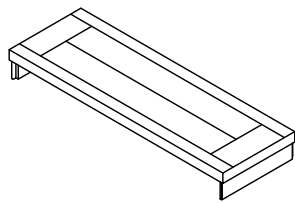
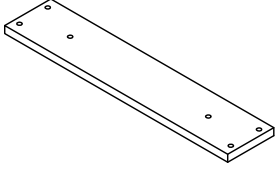
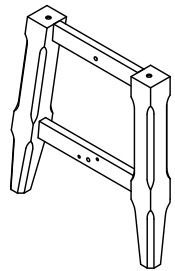
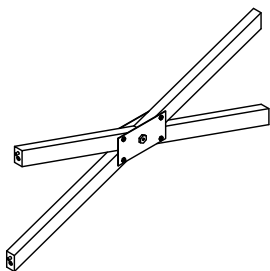

Place the Table Leaf (B) in position and push Table Top (A) from both ends to close. Lock the Latch underneath the Table Top (A) to prevent injury from sliding Table Top (A).



# PARTS LIST

<p><b>(A) Table Top (1Pc)</b></p> 	<p><b>(B) Table Leaf (2Pcs)</b></p> 	<p><b>(C) Mounting Plate (2Pcs)</b></p> 
<p><b>(D) Table Leg (2Pcs)</b></p> 	<p><b>(E) Trestle Bar (1Pc)</b></p> 	

## HARDWARE PACK

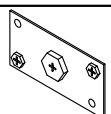
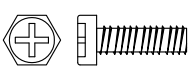
NO.		DESCRIPTION	DIMENSION	Q'TY
1	SHORT BOLT		Ø1/4"x 32mm	4PCS
2	LOCK WASHER		Ø5/16"x 12mm	16PCS
3	SMALL FLAT WASHER		Ø1/4"x 12mm	4PCS
4	ALLEN KEY		58x 23x 4mm	1PC
5	WOOD CAP		Ø13.5x 8mm	2PCS
6	MIDDLE BOLT		Ø5/16"x 45mm	4PCS
7	LARGE FLAT WASHER		Ø5/16"x 19mm	12PCS
8	LONG BOLT		Ø5/16"x 85mm	8PCS
9	METAL PLATE SMALL		100x 50x 7.5mm	2PCS
10	SHORT BOLT		Ø1/4"x 19mm	4PCS

# PARTS COMPLETE HARDWARE

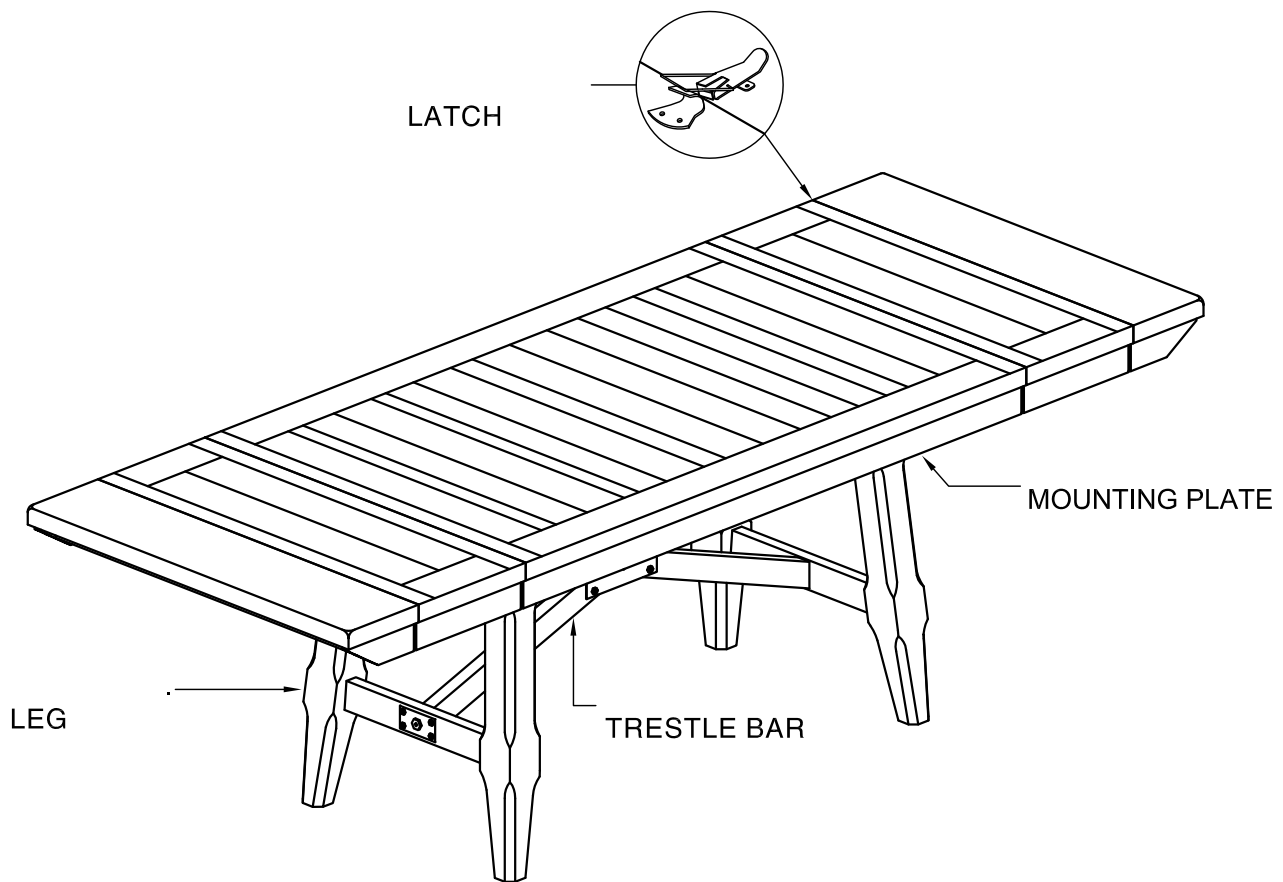

## PRODUCT DETAILS

TOP	MDF+ PINE VENEER & PINWOOD
APRON	PINWOOD
LEG	PINWOOD
TRESTLE BAR	PINWOOD
PRODUCT SIZE	36" x 72"x 84" x 96" W/Two 12" Leaves
CARTON SIZE TABLE TOP	76.18" x 39.96" x 8.26" H
NET WEIGHT	136.4 LBS
GROSS WEIGHT	148.5 LBS
CU.FT.	14.55'
CARTON SIZE TABLE BASE	46.85" x 26.77" x 10.03" H
NET WEIGHT	28.6 LBS
GROSS WEIGHT	33 LBS
CU.FT.	7.28'

**MADE IN VIETNAM**

## Description: Riverdale Side Chair

Product Size: 19"x 23"x 40"H

**Your furniture purchase is an investment. Here are a few tips to maximize the lifetime of your furniture with a minimum amount of effort. Properly caring for your furniture can help ensure that it looks great year after year.**

### Wood Furniture Maintenance:

- Always dust, wipe, and clean *with* the grain of the wood.
- Dust with a soft cloth. Dust will scratch the furniture surface if not removed properly.
- Use the same type of polish consistently as interchanging oil-based and wax-based polishes will cause a build-up and result in a foggy or cloudy appearance.
- If a polished surface becomes foggy, rub it with a cloth dipped in a solution of one tablespoon vinegar to one quart of water. Rub softly with the grain until the surface is completely dry.
- Soap and water are not advisable for wood surfaces. Water can penetrate the finish and raise the grain on wood, causing damage.
- Remember to change dusting cloths frequently as dirty cloths may scratch your furniture's surface.

### The Enemies of Wood:

- Moisture is wood's worst enemy. Liquid spills should be gently wiped up immediately. Coasters should be used under all beverages.
- Do not allow rubber or vinyl materials to lie on the furniture. Chemicals in rubber may leave a stain. Put a strip of felt or leather under accessories that have rubber or vinyl.
- Heat creates a chemical change in the furniture's finish, which results in a white spot. Use protective pads under hot dishes, appliances, etc.
- Sunlight's ultraviolet rays can damage the finish of furniture. Do not place furniture directly against a heater or radiator and do not place in the path of hot streams of air from central heating. This will cause extreme localized drying of the wood.

### High Gloss Resin Table Maintenance:

- Resin tabletops have approximately 1/8" of a resin coat on the top face of the table, which will resist ice, water, wine, liquor, food, cleaning fluids, and warm or hot liquids; however, cups, glasses, etc. containing hot liquids should not be left on the table without a coaster for protection.
- Resin tabletops will scratch just the same as any other glossy surface and basic precautions should be taken.
- For lasting shine, the resin table should be waxed with a car wax that does not contain silicon. Maintaining this wax build-up will result in a high gloss shine.
- When wiping down the table, a soft, clean rag should be used. Do not use a heavy paper.

### Granite Top Maintenance:

The surface of the granite on your table has been polished or sealed to create a generally non-porous surface. The stone has many natural characteristics including: veining, hairline cracks, and color variations - which make up the stone's beauty.

To maintain the beauty of your granite:

- Protect surfaces from scratching, staining and etching by:
  - \* Keeping them free of debris or sharp objects
  - \* Wiping up spills immediately
  - \* Avoiding contact with chemicals (particularly acid-based materials)
- Clean with pH neutral products or those especially formulated for use on stone.
- It is not recommended to use a water-based solvent for dark granite as it will remove the polish from the surface.
- After a period of use, apply a penetrating sealer to prevent contaminants from being absorbed into the stone.
- Remove stains with special absorbent poultices formulated for use on stone.
- Renew the surface on polished granite (granite with a high gloss surface ) by buffing with special stone polish , powder or cream .

Do not use granite polish on granite with a matte finish, which has been honed rather than polished. (Penetrating sealer may be used on both polished and honed granite.)

### Marble Top Maintenance:







Marble may be stone, but it is porous stone and can stain easily. Treating marble surfaces the same as wood surfaces is a great rule of thumb.

- It is recommended to seal the tops on a regular basis (every 6 to 12 months). A good quality stone sealer can be purchased from any tiles/stone store or any homecare store and should be applied according to the manufacturer's recommendation.
- When sealed properly, marble tops can be used indoors and outdoors and can withstand any weather conditions except internal freezing. Snow or freezing rain will penetrate the table and cause cracks.

### Caring for the Fabric on Upholstered Furniture:

- Frequent vacuuming of the entire upholstered area will prevent dust from settling into the fibers.
- Professional cleaning is always recommended for all upholstered pieces.
- Always pre-test a small area of fabric in an inconspicuous area when cleaning before proceeding.
- Do not use cleaning products containing brightening agents.

## VERY IMPORTANT!!

<p><b>NEVER</b> USE GLASS CLEANERS ON FINISHED SURFACES. AMMONIA WILL CHEMICALLY ATTACK THE FINISH.</p>	<p>DO NOT WRITE DIRECTLY ON SURFACE </p> <p><b>PREVENT MARKING</b></p>	<p>DO NOT PLACE DIRECTLY IN SUNLIGHT </p> <p><b>PREVENT FADING</b></p>	<p>DO NOT USE PLACEMATS WITH RUBBER BASES </p> <p><b>PREVENT DISCOLORING</b></p>
<p><b>NEVER</b> ALLOW LIQUIDS OF ANY KIND TO LINGER ON SURFACES. ABSORPTION CAUSES THE WOOD TO WARP AND THE FINISH TO DE-LAMINATE.</p>	<p>DO NOT USE COMMERCIAL POLISHES AND WAXES </p> <p><b>PREVENT YELLOWING</b></p>	<p>DO NOT PLACE HOT POTS, ETC. ON SURFACE </p> <p><b>PREVENT DAMAGE TO FINISH!</b></p>	<p>REGULATE THE HUMIDITY CONDITIONS AT YOUR HOME </p> <p><b>PREVENT SPLITTING</b></p>

# ASSEMBLY INSTRUCTIONS

DO NOT TIGHTEN BOLTS UNTIL TABLE IS COMPLETELY ASSEMBLED.

Step1: Turn the Chair Back (A) up side down. Attached Seat Box W/ Wooden Seat (B) to Chair Back (A) by using Flat Washer (1), Lock Washer (2) and Long Bolt (3) into the holes at the conners and insert Flat Washer (1), Lock Washer (2), Short Bolt (5) into the holes at the rear bar of Seat Box w/ Wooden Seat (B). Tighten all bolts with the Allen Key (6). Do not fully tighten all bolts at this stage.

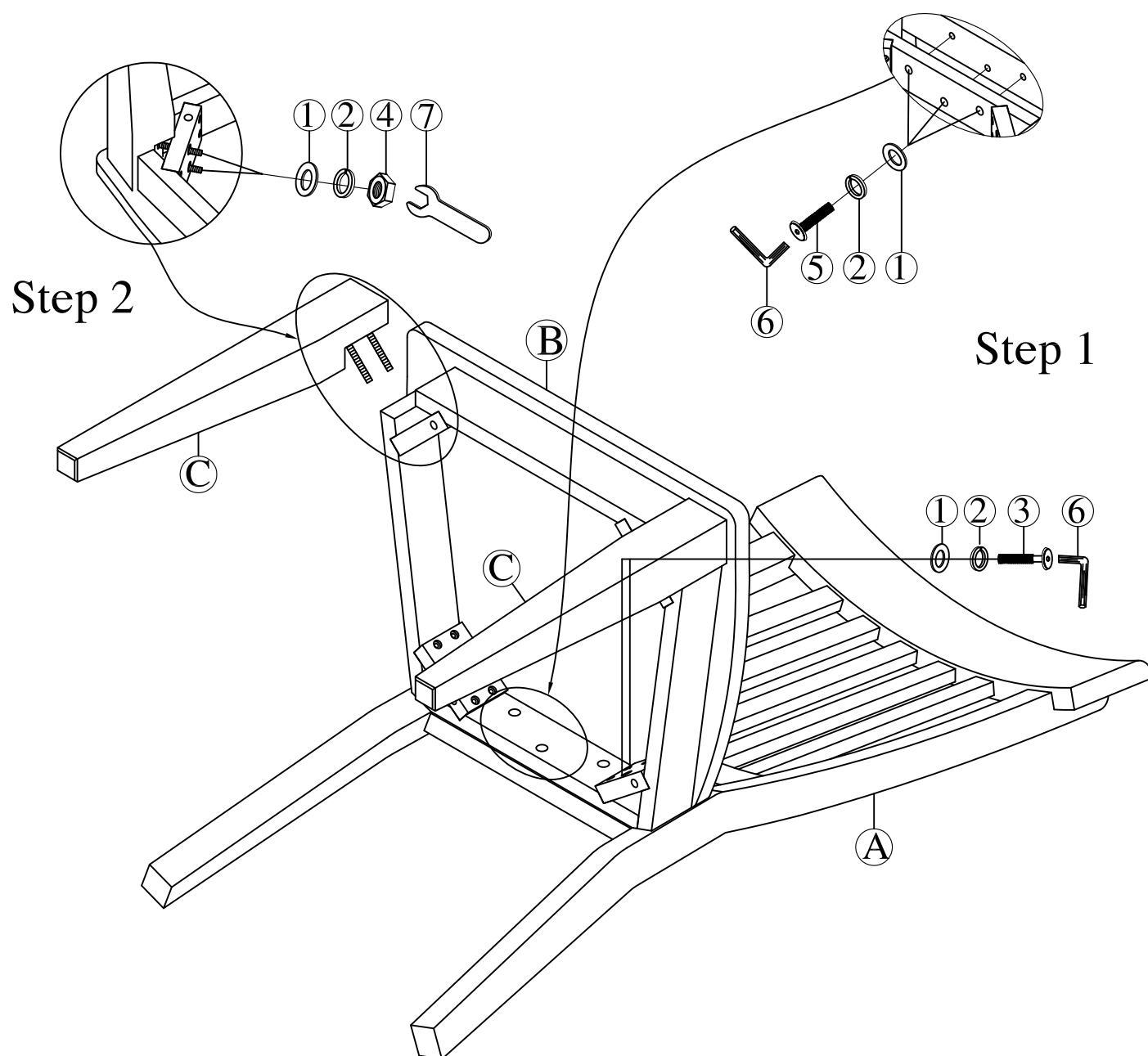

Step2: Attached Front Leg (C) into Seat Box w/ Wooden Seat (B) by using Flat Washer (1), Lock Washer (2), Hex Nut (4) and tighten with Wrench (7). Now fully tighten all bolts. Assembly is now completed.

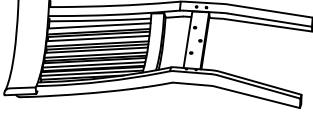
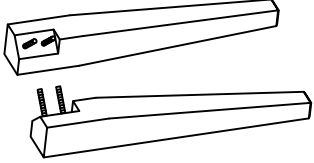
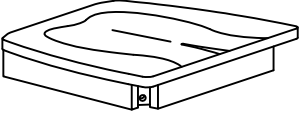

# PARTS LIST

A	CHAIR BACK (1PC)		C	FRONT LEG (2PCS)	
B	SEAT BOX w/ WOODEN SEAT (1PC)				

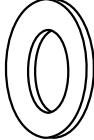
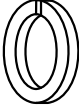
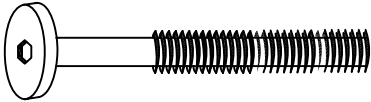
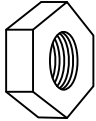
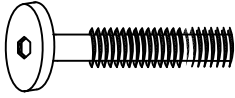
## HARDWARE PACK

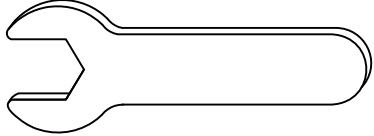
NO.	DESCRIPTION	DIMENSION	Q'TY
1	FLAT WASHER 	Ø5/16" x 19mm	11pcs
2	LOCK WASHER 	Ø5/16" x 12mm	11pcs
3	LONG BOLT 	Ø1/4" x 85	4pcs
4	HEX NUT 	Ø5/16" x 12	4pcs
5	SHORT BOLT 	Ø1/4" x 38	3pcs
6	ALLEN KEY 	NO.4	1pc
7	WRENCH 	NO.12	1pc

# PARTS

## COMPLETE HARDWARE

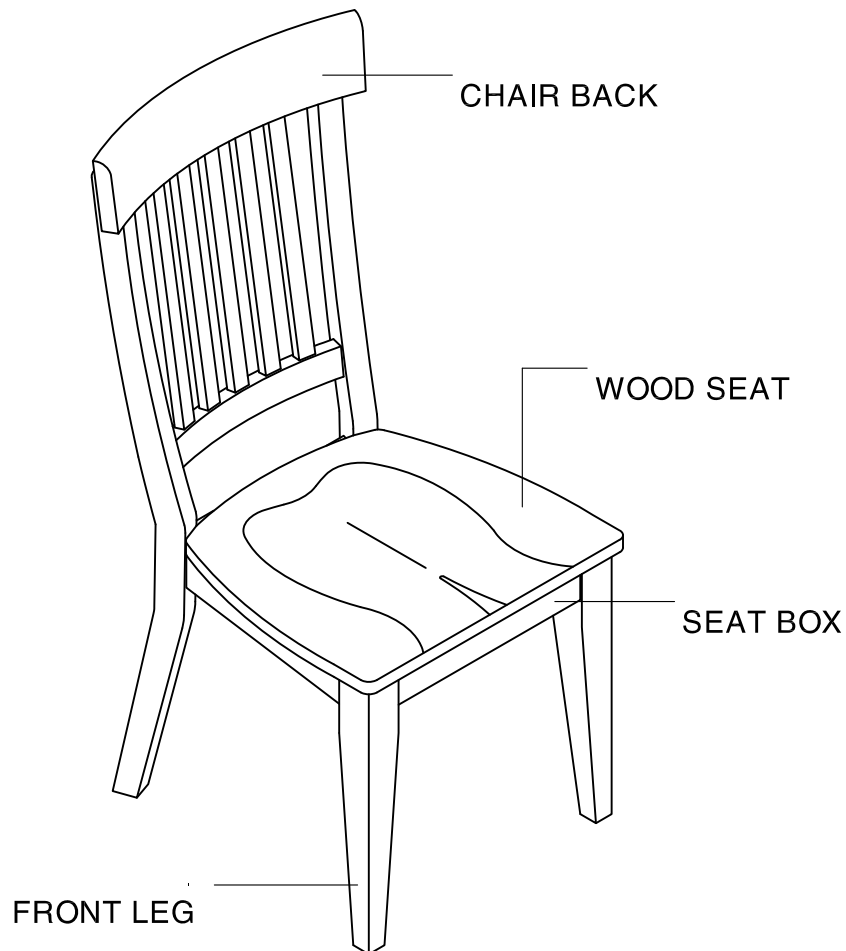

PRODUCT DETAILS	
SEAT BOX	RUBBER WOOD & PINEWOOD
CHAIR BACK	RUBBER WOOD & BENTWOOD
LEG	RUBBER WOOD
PRODUCT SIZE	19"x 23"x 40"H
CARTON SIZE	41.73" x 20.08" x 11.22"H
NET WEIGHT	39.6 LBS/ 2PCS
GROSS WEIGHT	46.2 LBS/ 2PCS
CU.FT.	5.44'

**MADE IN VIETNAM**

## **Company Dining Chairs - Assembly Troubleshooting Guide**

The most important element of correct chair assembly is to tighten the bolts as directed. Prematurely tightening the bolts can lead to numerous issues and will lengthen the assembly time. Listed below are the most common issues in chair assembly and their easy solutions.

### **PROBLEM: Chair is unlevel.**

#### **Cause 1:**

Unlevel chairs can occur if the bolts are fully tightened before all bolts are attached. There is a variance in the alignment of this chair to allow the chair to be assembled more easily.

#### **Solution:**

Loosen each bolt in the seat box (front legs, back corner blocks and back apron) until they are finger tight. Place the chair upright on the floor. Sit in the chair for about 30 seconds. Carefully turn the chair upside down and tighten each bolt. The chair will now be level.

#### **Cause 2:**

Unlevel chairs can occur if one or more of the floor glides are missing from the bottom of the chair leg.

#### **Solution:**

Request a set of floor glides from the e-mail address below.

### **PROBLEM: Bolts do not fit properly.**

#### **Cause:**

This issue can occur when the bolts are tightened fully before all bolts are attached. There is a variance in the alignment of the bolts to allow the chair to be assembled more easily. Tightening the bolts prematurely can cause the holes for the other bolts to become slightly misaligned, causing the remaining bolts not to fit properly.

#### **Solution:**

Make sure each bolt in the seat box (front legs, back corner blocks and back apron) is loosened until finger tight. This will allow you to realign the holes, and the bolts will now fit properly.

## Description: Riverdale Bench

Product Size: 60"x 16"x 20"H

**Your furniture purchase is an investment. Here are a few tips to maximize the lifetime of your furniture with a minimum amount of effort. Properly caring for your furniture can help ensure that it looks great year after year.**

### Wood Furniture Maintenance:

- Always dust, wipe, and clean *with* the grain of the wood.
- Dust with a soft cloth. Dust will scratch the furniture surface if not removed properly.
- Use the same type of polish consistently as interchanging oil-based and wax-based polishes will cause a build-up and result in a foggy or cloudy appearance.
- If a polished surface becomes foggy, rub it with a cloth dipped in a solution of one tablespoon vinegar to one quart of water. Rub softly with the grain until the surface is completely dry.
- Soap and water are not advisable for wood surfaces. Water can penetrate the finish and raise the grain on wood, causing damage.
- Remember to change dusting cloths frequently as dirty cloths may scratch your furniture's surface.

### The Enemies of Wood:

- Moisture is wood's worst enemy. Liquid spills should be gently wiped up immediately. Coasters should be used under all beverages.
- Do not allow rubber or vinyl materials to lie on the furniture. Chemicals in rubber may leave a stain. Put a strip of felt or leather under accessories that have rubber or vinyl.
- Heat creates a chemical change in the furniture's finish, which results in a white spot. Use protective pads under hot dishes, appliances, etc.
- Sunlight's ultraviolet rays can damage the finish of furniture. Do not place furniture directly against a heater or radiator and do not place in the path of hot streams of air from central heating. This will cause extreme localized drying of the wood.

### High Gloss Resin Table Maintenance:

- Resin tabletops have approximately 1/8" of a resin coat on the top face of the table, which will resist ice, water, wine, liquor, food, cleaning fluids, and warm or hot liquids; however, cups, glasses, etc. containing hot liquids should not be left on the table without a coaster for protection.
- Resin tabletops will scratch just the same as any other glossy surface and basic precautions should be taken.
- For lasting shine, the resin table should be waxed with a car wax that does not contain silicon. Maintaining this wax build-up will result in a high gloss shine.
- When wiping down the table, a soft, clean rag should be used. Do not use a heavy paper.

### Granite Top Maintenance:

The surface of the granite on your table has been polished or sealed to create a generally non-porous surface. The stone has many natural characteristics including: veining, hairline cracks, and color variations - which make up the stone's beauty.

To maintain the beauty of your granite:

- Protect surfaces from scratching, staining and etching by:
  - \* Keeping them free of debris or sharp objects
  - \* Wiping up spills immediately
  - \* Avoiding contact with chemicals (particularly acid-based materials)
- Clean with pH neutral products or those especially formulated for use on stone.
- It is not recommended to use a water-based solvent for dark granite as it will remove the polish from the surface.
- After a period of use, apply a penetrating sealer to prevent contaminants from being absorbed into the stone.
- Remove stains with special absorbent poultices formulated for use on stone.
- Renew the surface on polished granite (granite with a high gloss surface ) by buffing with special stone polish , powder or cream .

Do not use granite polish on granite with a matte finish, which has been honed rather than polished. (Penetrating sealer may be used on both polished and honed granite.)

### Marble Top Maintenance:







Marble may be stone, but it is porous stone and can stain easily. Treating marble surfaces the same as wood surfaces is a great rule of thumb.

- It is recommended to seal the tops on a regular basis (every 6 to 12 months). A good quality stone sealer can be purchased from any tiles/stone store or any homecare store and should be applied according to the manufacturer's recommendation.
- When sealed properly, marble tops can be used indoors and outdoors and can withstand any weather conditions except internal freezing. Snow or freezing rain will penetrate the table and cause cracks.

### Caring for the Fabric on Upholstered Furniture:

- Frequent vacuuming of the entire upholstered area will prevent dust from settling into the fibers.
- Professional cleaning is always recommended for all upholstered pieces.
- Always pre-test a small area of fabric in an inconspicuous area when cleaning before proceeding.
- Do not use cleaning products containing brightening agents.

# VERY IMPORTANT!!

<p><b>NEVER</b> USE GLASS CLEANERS ON FINISHED SURFACES. AMMONIA WILL CHEMICALLY ATTACK THE FINISH.</p>	<p>DO NOT WRITE DIRECTLY ON SURFACE </p> <p><b>PREVENT MARKING</b></p>	<p>DO NOT PLACE DIRECTLY IN SUNLIGHT </p> <p><b>PREVENT FADING</b></p>	<p>DO NOT USE PLACEMATS WITH RUBBER BASES </p> <p><b>PREVENT DISCOLORING</b></p>
<p><b>NEVER</b> ALLOW LIQUIDS OF ANY KIND TO LINGER ON SURFACES. ABSORPTION CAUSES THE WOOD TO WARP AND THE FINISH TO DE-LAMINATE.</p>	<p>DO NOT USE COMMERCIAL POLISHES AND WAXES </p> <p><b>PREVENT YELLOWING</b></p>	<p>DO NOT PLACE HOT POTS, ETC. ON SURFACE </p> <p><b>PREVENT DAMAGE TO FINISH!</b></p>	<p>REGULATE THE HUMIDITY CONDITIONS AT YOUR HOME </p> <p><b>PREVENT SPLITTING</b></p>

# ASSEMBLY INSTRUCTIONS

DO NOT TIGHTEN BOLTS UNTIL TABLE IS COMPLETELY ASSEMBLED.

Step1: Turn the Seat Box W/Seat Cushion (A) up side down on a flat soft surface. Attached Bench Leg (B) to Seat Box W/Seat Cushion (A) by using Flat Washer (1), Lock Washer (2) and Long Bolt (3) into the holes at the conners. Tighten all bolts with the Allen Key (5). Do not fully tighten all bolts at this stage.

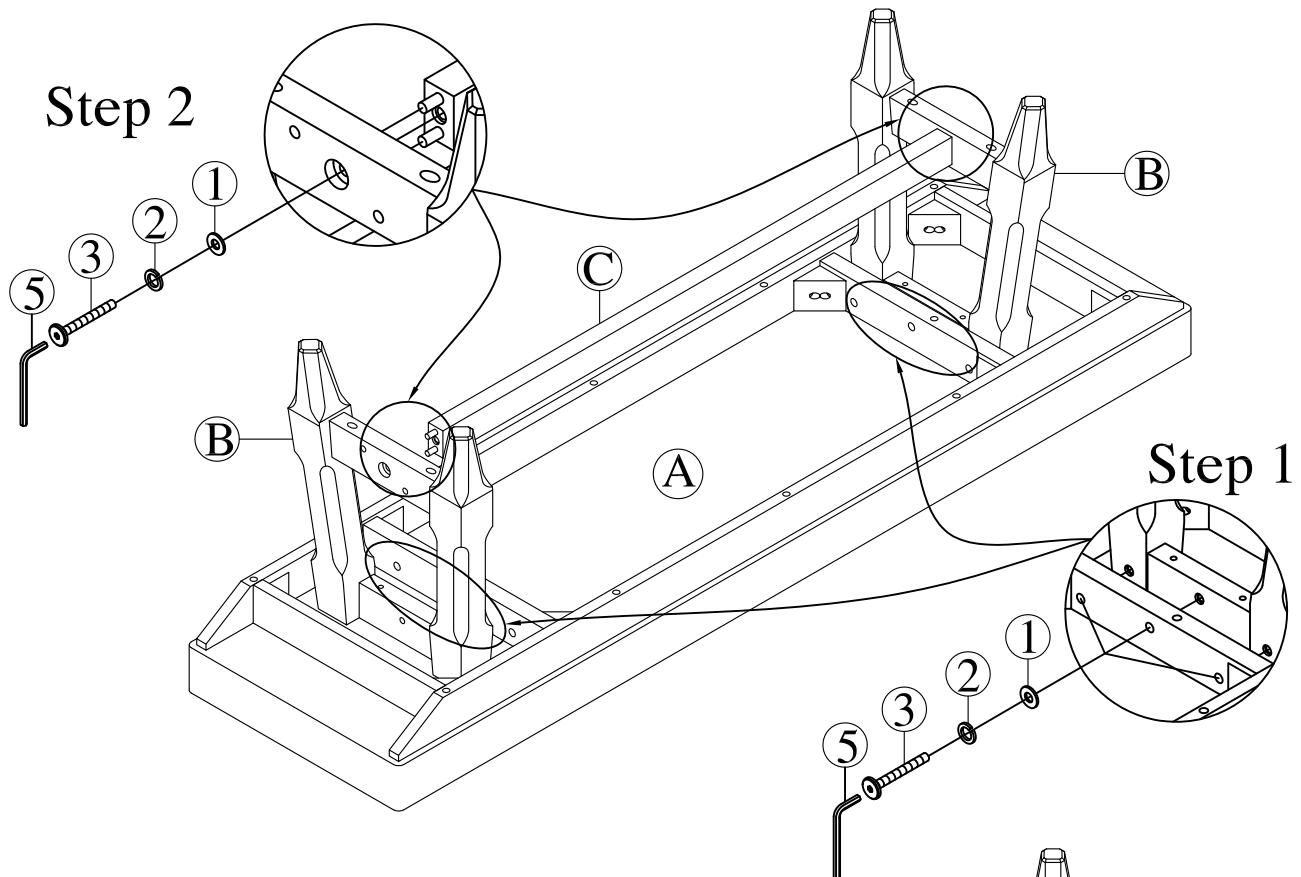

Step2: Attached Center Stretcher (C) into Bench Leg (B) by using Flat Washer (1), Lock Washer (2), Long Bolt (3) and tighten with Allen Key (5). Now fully tighten all bolts

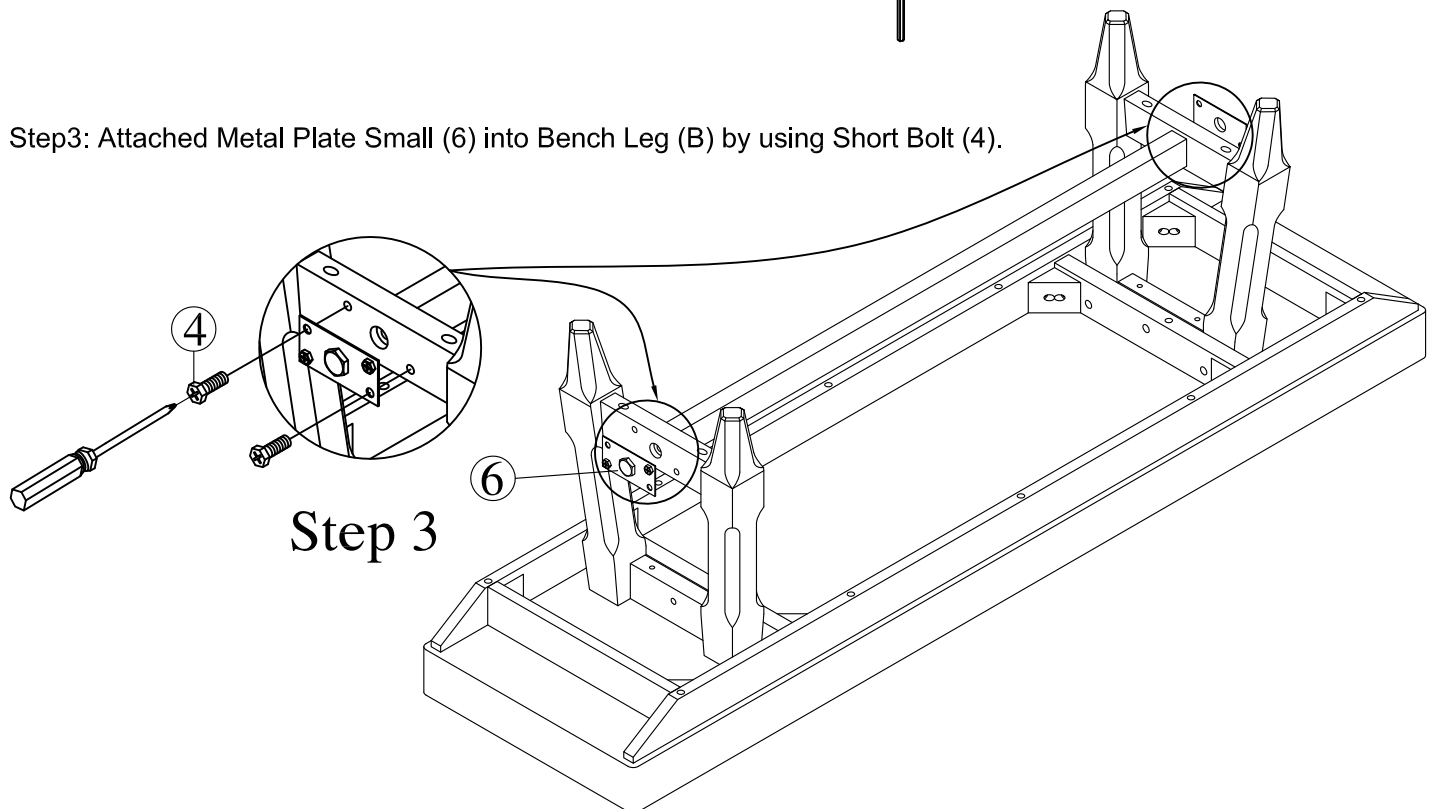

Step3: Attached Metal Plate Small (6) into Bench Leg (B) by using Short Bolt (4).

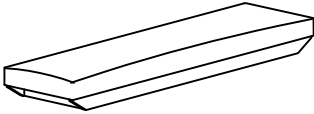

# PARTS LIST

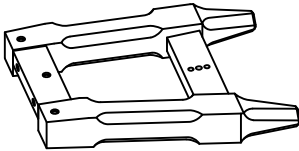
A	SEAT BOX w/ SEAT CUSHION (1PC)		C	CENTER STRETCHER (1PC)	
B	BENCH LEG (2PCS)				

## HARDWARE PACK

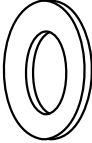
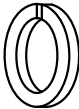
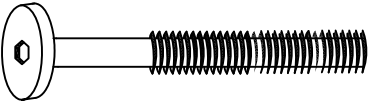
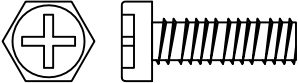
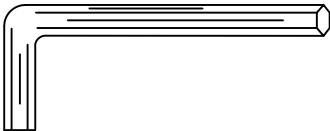
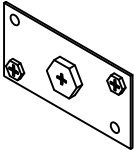
NO.	DESCRIPTION	DIMENSION	Q'TY
1	FLAT WASHER 	Ø5/16" x 19mm	8pcs
2	LOCK WASHER 	Ø5/16" x 12mm	8pcs
3	LONG BOLT 	Ø1/4" x 57	8pcs
4	SHORT BOLT 	Ø1/4" x 19	4pcs
5	ALLEN KEY 	NO.4	1pc
6	METAL PLATE SMALL 	100 x 50 x 7.5 mm	2pcs

# PARTS

## COMPLETE HARDWARE

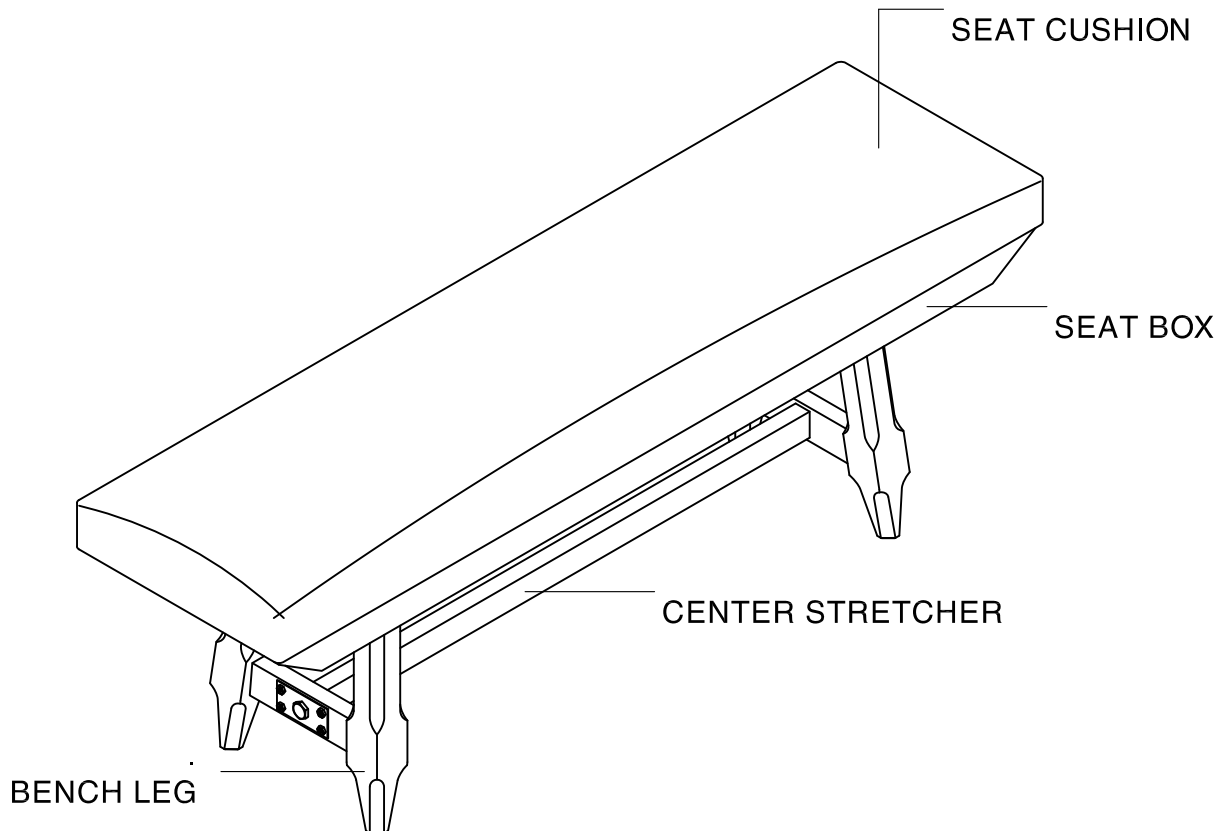

PRODUCT DETAILS	
SEAT BOX	RUBBER WOOD & PINEWOOD
STRETCHER	PINEWOOD
BENCH LEG	PINEWOOD
PRODUCT SIZE	60"x 16"x 20"H
CARTON SIZE	63.38" x 19.29" x 8.86"H
NET WEIGHT	31.9 LBS
GROSS WEIGHT	39.6 LBS
CU.FT.	6.27'

**MADE IN VIETNAM**

## Description: Riverdale Upholstered Chair

Product Size: 20"x 25"x 40"H

**Your furniture purchase is an investment. Here are a few tips to maximize the lifetime of your furniture with a minimum amount of effort. Properly caring for your furniture can help ensure that it looks great year after year.**

### Wood Furniture Maintenance:

- Always dust, wipe, and clean *with* the grain of the wood.
- Dust with a soft cloth. Dust will scratch the furniture surface if not removed properly.
- Use the same type of polish consistently as interchanging oil-based and wax-based polishes will cause a build-up and result in a foggy or cloudy appearance.
- If a polished surface becomes foggy, rub it with a cloth dipped in a solution of one tablespoon vinegar to one quart of water. Rub softly with the grain until the surface is completely dry.
- Soap and water are not advisable for wood surfaces. Water can penetrate the finish and raise the grain on wood, causing damage.
- Remember to change dusting cloths frequently as dirty cloths may scratch your furniture's surface.

### The Enemies of Wood:

- Moisture is wood's worst enemy. Liquid spills should be gently wiped up immediately. Coasters should be used under all beverages.
- Do not allow rubber or vinyl materials to lie on the furniture. Chemicals in rubber may leave a stain. Put a strip of felt or leather under accessories that have rubber or vinyl.
- Heat creates a chemical change in the furniture's finish, which results in a white spot. Use protective pads under hot dishes, appliances, etc.
- Sunlight's ultraviolet rays can damage the finish of furniture. Do not place furniture directly against a heater or radiator and do not place in the path of hot streams of air from central heating. This will cause extreme localized drying of the wood.

### High Gloss Resin Table Maintenance:

- Resin tabletops have approximately 1/8" of a resin coat on the top face of the table, which will resist ice, water, wine, liquor, food, cleaning fluids, and warm or hot liquids; however, cups, glasses, etc. containing hot liquids should not be left on the table without a coaster for protection.
- Resin tabletops will scratch just the same as any other glossy surface and basic precautions should be taken.
- For lasting shine, the resin table should be waxed with a car wax that does not contain silicon. Maintaining this wax build-up will result in a high gloss shine.
- When wiping down the table, a soft, clean rag should be used. Do not use a heavy paper.

### Granite Top Maintenance:

The surface of the granite on your table has been polished or sealed to create a generally non-porous surface. The stone has many natural characteristics including: veining, hairline cracks, and color variations - which make up the stone's beauty.

To maintain the beauty of your granite:

- Protect surfaces from scratching, staining and etching by:
    - \* Keeping them free of debris or sharp objects
    - \* Wiping up spills immediately
    - \* Avoiding contact with chemicals (particularly acid-based materials)
  - Clean with pH neutral products or those especially formulated for use on stone.
  - It is not recommended to use a water-based solvent for dark granite as it will remove the polish from the surface.
  - After a period of use, apply a penetrating sealer to prevent contaminants from being absorbed into the stone.
  - Remove stains with special absorbent poultices formulated for use on stone.
  - Renew the surface on polished granite (granite with a high gloss surface ) by buffing with special stone polish , powder or cream .
- Do not use granite polish on granite with a matte finish, which has been honed rather than polished. (Penetrating sealer may be used on both polished and honed granite.)

### Marble Top Maintenance:







Marble may be stone, but it is porous stone and can stain easily. Treating marble surfaces the same as wood surfaces is a great rule of thumb.

- It is recommended to seal the tops on a regular basis (every 6 to 12 months). A good quality stone sealer can be purchased from any tiles/stone store or any homeware store and should be applied according to the manufacturer's recommendation.
- When sealed properly, marble tops can be used indoors and outdoors and can withstand any weather conditions except internal freezing. Snow or freezing rain will penetrate the table and cause cracks.

### Caring for the Fabric on Upholstered Furniture:

- Frequent vacuuming of the entire upholstered area will prevent dust from settling into the fibers.
- Professional cleaning is always recommended for all upholstered pieces.
- Always pre-test a small area of fabric in an inconspicuous area when cleaning before proceeding.
- Do not use cleaning products containing brightening agents.

## VERY IMPORTANT!!

<p><b>NEVER</b> USE GLASS CLEANERS ON FINISHED SURFACES. AMMONIA WILL CHEMICALLY ATTACK THE FINISH.</p>	<p>DO NOT WRITE DIRECTLY ON SURFACE </p> <p><b>PREVENT MARKING</b></p>	<p>DO NOT PLACE DIRECTLY IN SUNLIGHT </p> <p><b>PREVENT FADING</b></p>	<p>DO NOT USE PLACEMATS WITH RUBBER BASES </p> <p><b>PREVENT DISCOLORING</b></p>
<p><b>NEVER</b> ALLOW LIQUIDS OF ANY KIND TO LINGER ON SURFACES. ABSORPTION CAUSES THE WOOD TO WARP AND THE FINISH TO DE-LAMINATE.</p>	<p>DO NOT USE COMMERCIAL POLISHES AND WAXES </p> <p><b>PREVENT YELLOWING</b></p>	<p>DO NOT PLACE HOT POTS, ETC. ON SURFACE </p> <p><b>PREVENT DAMAGE TO FINISH!</b></p>	<p>REGULATE THE HUMIDITY CONDITIONS AT YOUR HOME </p> <p><b>PREVENT SPLITTING</b></p>

# ASSEMBLY INSTRUCTIONS



DO NOT TIGHTEN BOLTS UNTIL TABLE IS COMPLETELY ASSEMBLED.

Step1: Turn the Chair Back (A) up side down. Attached Seat Box W/Seat Cushion (B) to Chair Back (A) by using Flat Washer (1), Lock Washer (2) and Long Bolt (3) into the holes at the conners and insert Flat Washer (1), Lock Washer (2), Short Bolt (4) into the holes at the rear bar of Seat Box w/ Seat Cushion (B).Tighten all bolts with the Allen Key (6).

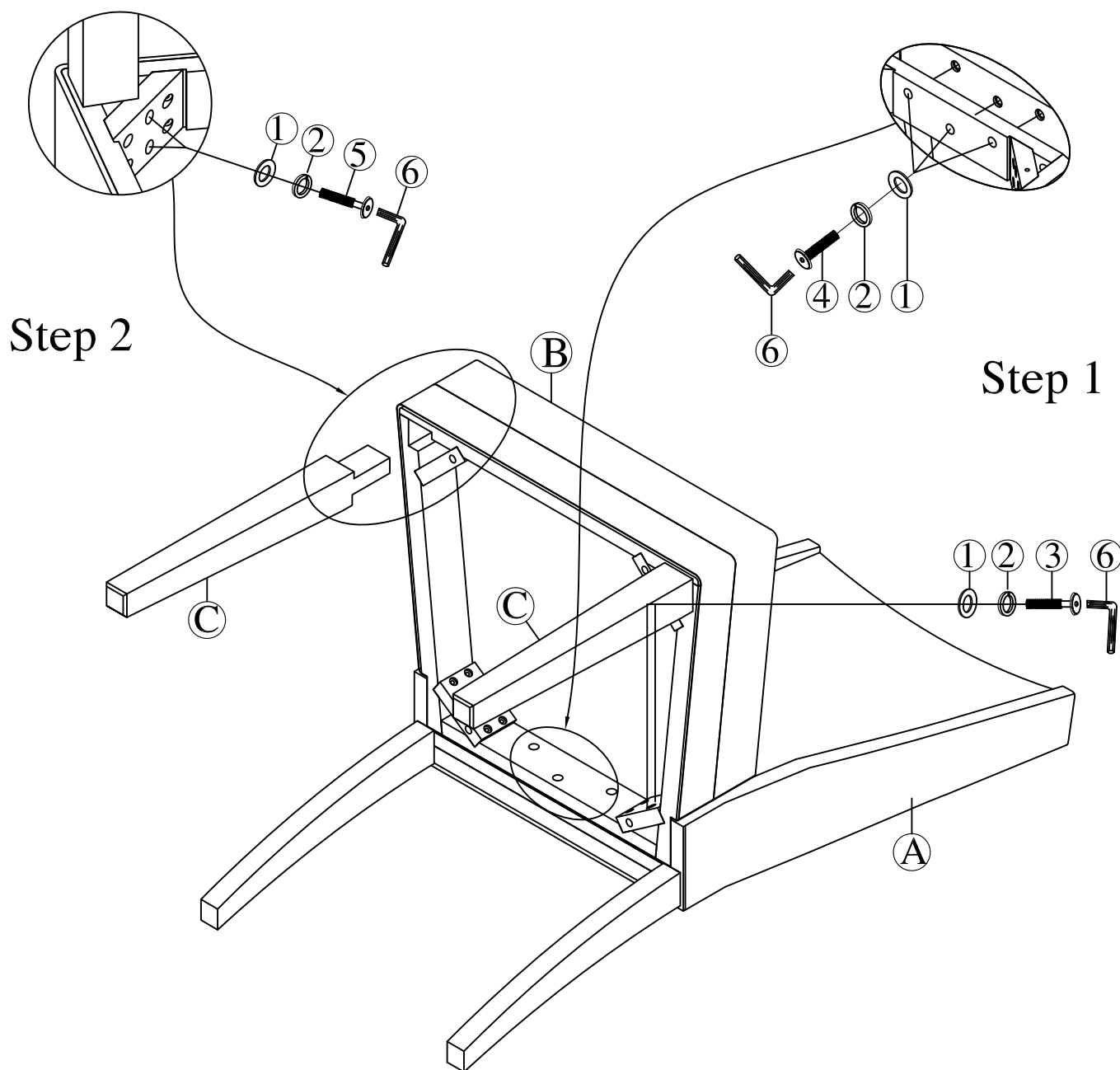
Step2: Attached Front Leg (C) into Seat Box w/ Seat Cushion (B) by using Flat Washer (1), Lock Washer (2), Middle Bolt (5) and tighten with Allen Key (6). Assembly is now completed.

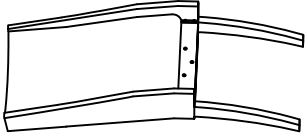

# PARTS LIST

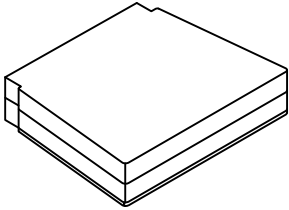
A	CHAIR BACK (1PC)		C	FRONT LEG (2PCS)	
B	SEAT BOX w/ SEAT CUSHION (1PC)				

## HARDWARE PACK

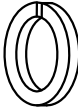
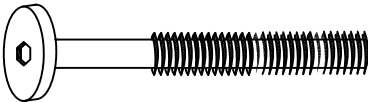
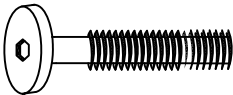
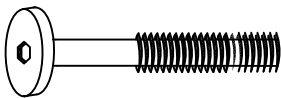
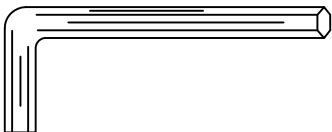
NO.	DESCRIPTION	DIMENSION	Q'TY
1	FLAT WASHER 	Ø5/16" x 19mm	11pcs
2	LOCK WASHER 	Ø5/16" x 12mm	11pcs
3	LONG BOLT 	Ø1/4" x 90	4pcs
4	SHORT BOLT 	Ø1/4" x 42	3pcs
5	MIDDLE BOLT 	Ø1/4" x 57	4pcs
6	ALLEN KEY 	NO.4	1pc

# PARTS

## COMPLETE HARDWARE

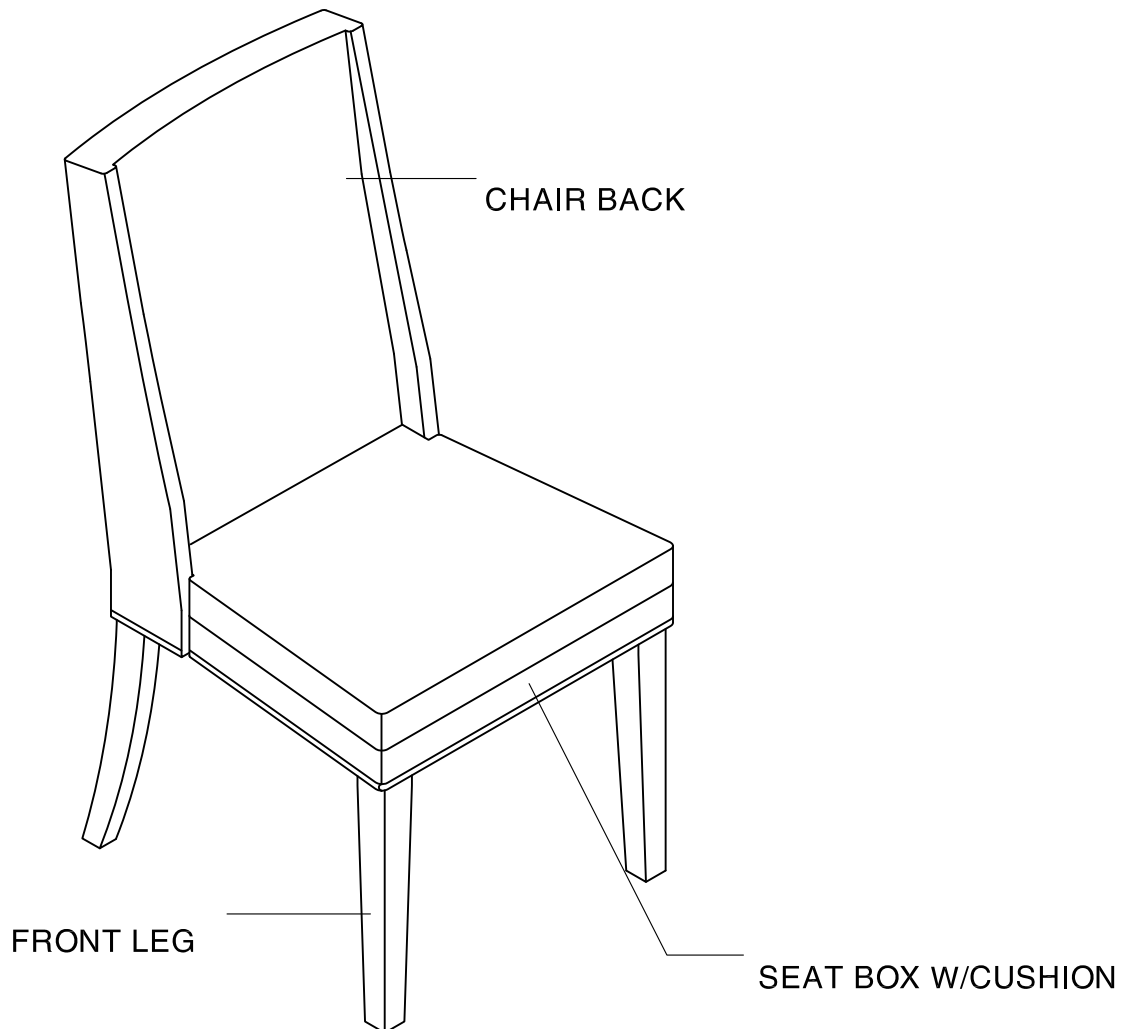

PRODUCT DETAILS	
SEAT BOX	RUBBER WOOD
CHAIR BACK	RUBBER WOOD & BENTWOOD
LEG	RUBBER WOOD
PRODUCT SIZE	20"x 25"x 40"H
CARTON SIZE	41.34" x 19.29" x 18.50"H
NET WEIGHT	44 LBS/ 2PCS
GROSS WEIGHT	50.6 LBS/ 2PCS
CU.FT.	8.54'

**MADE IN VIETNAM**

## **Company Dining Chairs - Assembly Troubleshooting Guide**

The most important element of correct chair assembly is to tighten the bolts as directed. Prematurely tightening the bolts can lead to numerous issues and will lengthen the assembly time. Listed below are the most common issues in chair assembly and their easy solutions.

### **PROBLEM: Chair is unlevel.**

#### **Cause 1:**

Unlevel chairs can occur if the bolts are fully tightened before all bolts are attached. There is a variance in the alignment of this chair to allow the chair to be assembled more easily.

#### **Solution:**

Loosen each bolt in the seat box (front legs, back corner blocks and back apron) until they are finger tight. Place the chair upright on the floor. Sit in the chair for about 30 seconds. Carefully turn the chair upside down and tighten each bolt. The chair will now be level.

#### **Cause 2:**

Unlevel chairs can occur if one or more of the floor glides are missing from the bottom of the chair leg.

#### **Solution:**

Request a set of floor glides from the e-mail address below.

---

### **PROBLEM: Bolts do not fit properly.**

#### **Cause:**

This issue can occur when the bolts are tightened fully before all bolts are attached. There is a variance in the alignment of the bolts to allow the chair to be assembled more easily. Tightening the bolts prematurely can cause the holes for the other bolts to become slightly misaligned, causing the remaining bolts not to fit properly.

#### **Solution:**

Make sure each bolt in the seat box (front legs, back corner blocks and back apron) is loosened until finger tight. This will allow you to realign the holes, and the bolts will now fit properly.