

# Assembly Instruction

**Tools Required:** Flathead screwdriver, Phillips screwdriver, pliers, wire cutters, wire strippers, electrical tape, safety glasses.

**Light Source:** (1) A19 Medium Base bulb 100W Maximum or  
(1) Medium Base Vintage bulb is recommended but not supplied.

**Estimated Assembly Time:** 20-30 minutes

**Preparation:** Identify and inspect all parts before beginning installation. Check package content list and diagrams below to be sure all parts are present. If any parts are missing or damaged, do not attempt to assemble, install, or operate the fixture. Contact customer service for replacement parts.

**Fixture can only be mounted in the direction indicated on page 2.**

## ⚠ Warnings and Cautions

Turn off electricity at circuit breaker or main fuse box before installation. Consult a licensed electrician if in doubt.

These instructions are provided for your safety. It is very important you read them completely before installing the fixture. We strongly recommend that a licensed, professional electrician perform the installation.

Disconnect fixture from power source before replacing bulbs. Make sure bulbs are given sufficient time to cool before removal.

## Package Contents

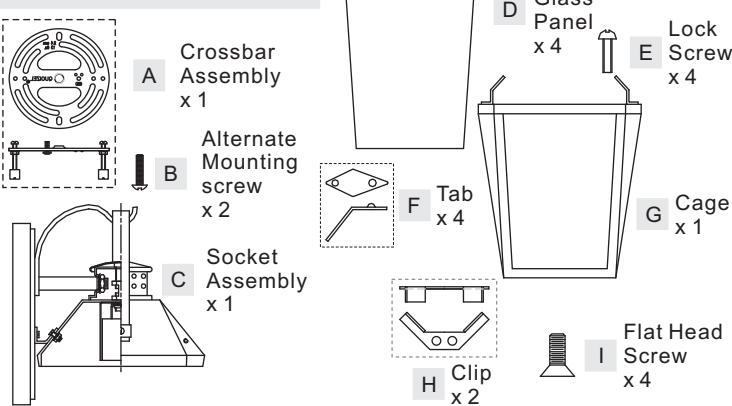

## (Step 2 Continued)

Cage (G). Attach Tabs (F) onto fixture hood and secure with Lock Screws (E). Tighten until snug with screwdrivers.

## STEP 3 - Install Crossbar Assembly

A. Pass the supply wires through the Crossbar Assembly (A). Attach the Crossbar Assembly (A) to the Outlet Box with the head of the Green Ground Screw facing you. Secure it with Outlet Box Screws (not included). Tighten until snug.  
Note: Use the Alternate Shorter Mounting Screw (B) if your installation requires a shorter mounting screw.

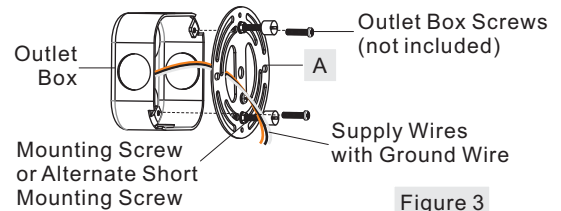

Figure 3

## STEP 1 - Install Bulb

A. Insert bulb onto socket and screw snugly into place.

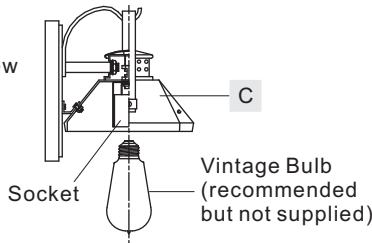

Figure 1

## STEP 2 - Attach Glass Panels and Cage to Socket Assembly

A. Insert Glass Panels (D) into the slot in the bottom edge of the Cage (G) properly. Place Clips (H) on the top edge of the Cage (G) to hold

Glass Panels (D), secure by threading Flat Head Screws (I) onto Cage (G). Tighten until snug. (See view A)

B. Attach fixture hood of Socket Assembly (C) onto top edge of Cage (G) and align holes on the fixture hood to mounting holes on Tabs at the top edge of the

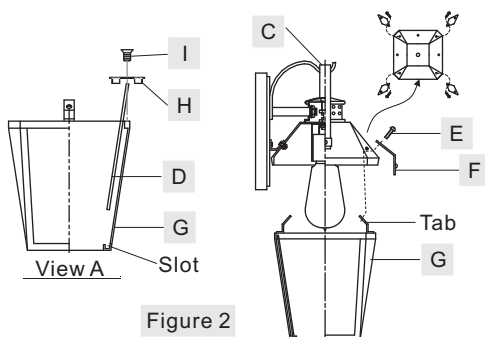

Figure 2

## STEP 4 - Test Fitting Backplate to Crossbar Assembly

A. Remove mounting balls from the Crossbar Assembly (A). Fit the backplate on Socket Assembly (C) to the Crossbar Assembly (A) and secure with mounting balls. Note: The backplate on Socket Assembly (C) should be snug against the wall and the mounting balls. If not, adjust the length of the mounting screw or alternate short mounting screw on the Crossbar Assembly (A) by unscrewing the preassembled hex nut and lock washer and then screwing the mounting screws or alternate short mounting screws in or out of the crossbar until the correct length is achieved. Once the backplate on Socket Assembly (C) is secure, remove the mounting ball and Socket Assembly (C) and proceed to Step 5.

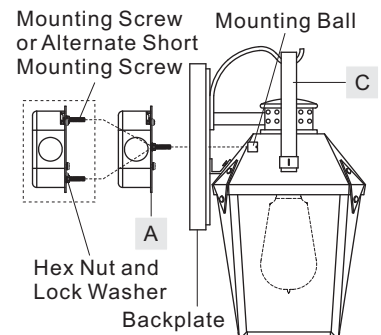
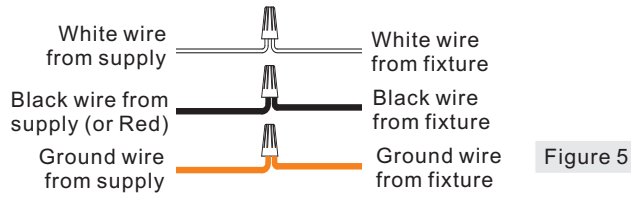

Figure 4

**STEP 5 - Wire Connections**

A. Use standard wire connectors (not included) to make all wire connections. Twist connectors until wires are tightly joined together. Wrap each connection with approved electrical tape and carefully stuff all the connected wires into the Outlet Box.



**STEP 6 - Install Fixture Body**

A. Carefully tuck all wires into the outlet box and position the backplate of Socket Assembly (C) over the outlet box. Align the holes in the backplate with the mounting screws or alternate short mounting screws. Place caulk (not supplied) into the previously removed mounting balls and then attach Socket Assembly (C) using the mounting balls. Hand tighten until snug.

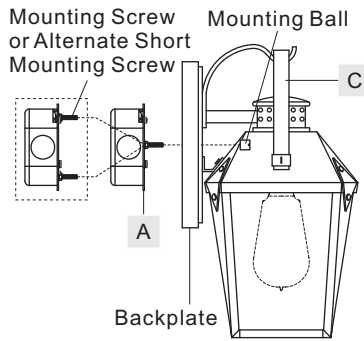

**STEP 7 - Apply Silicone Sealer**

A. Make sure exterior wall surface and fixture backplate are free of dirt before applying caulk. Using exterior grade caulk, caulk over top of backplate and down other side. Do not caulk bottom of fixture backplate to ensure proper moisture drainage.

Your fixture is now assembled and ready to use. Enjoy!

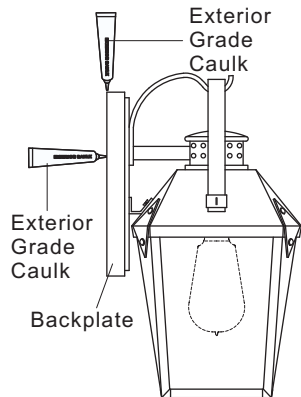

FINISH: MOTTLED BLACK

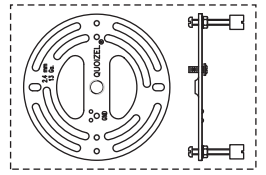

↑  
Fixture can only be mounted in the direction indicated

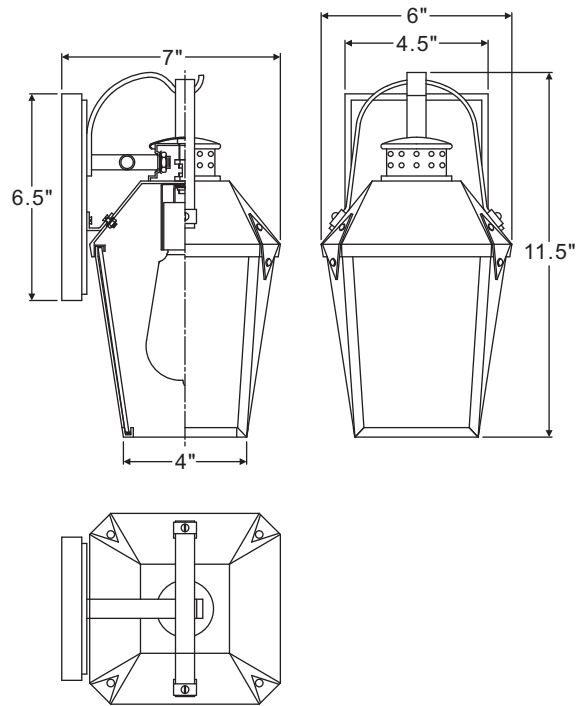

NOTE: ALL DIMENSIONS ARE ROUNDED UP TO THE NEAREST 1/4"