











# Assembly Instructions

**Caution: You must read these Assembly Instructions before you proceed**

## Care & Maintenance

- ⊘  ● Prolonged exposure to rain may cause rusting which can stain floors.
- ⊘  ● Do not put hot items directly on furniture surface.
- ⊘  ● Do not clean furniture with harsh cleansers or polish.
- ✓  ● To obtain the longest lifespan of your outdoor products, minimizing exposure to direct sunlight is recommended.
- ⊘  ● Children should not climb or jump on the furniture.
- ⊘  ● Do not write on furniture without a padded barrier to protect the surface.
- ✓  ● To obtain the longest lifespan of your outdoor products, avoid extended and lengthy exposure to rain, snow, and direct sunshine. Whenever possible cover the product and /or place under patio or awnings.
- ⊘  ● Not for commercial use. For residential use only
- ⊘  ● Stains may be removed with mild soap solution and damp cloth.
- ✓  ● Dust and pick-up spills using a clean, non-colored, lint-free cloth.

# LOUNGER



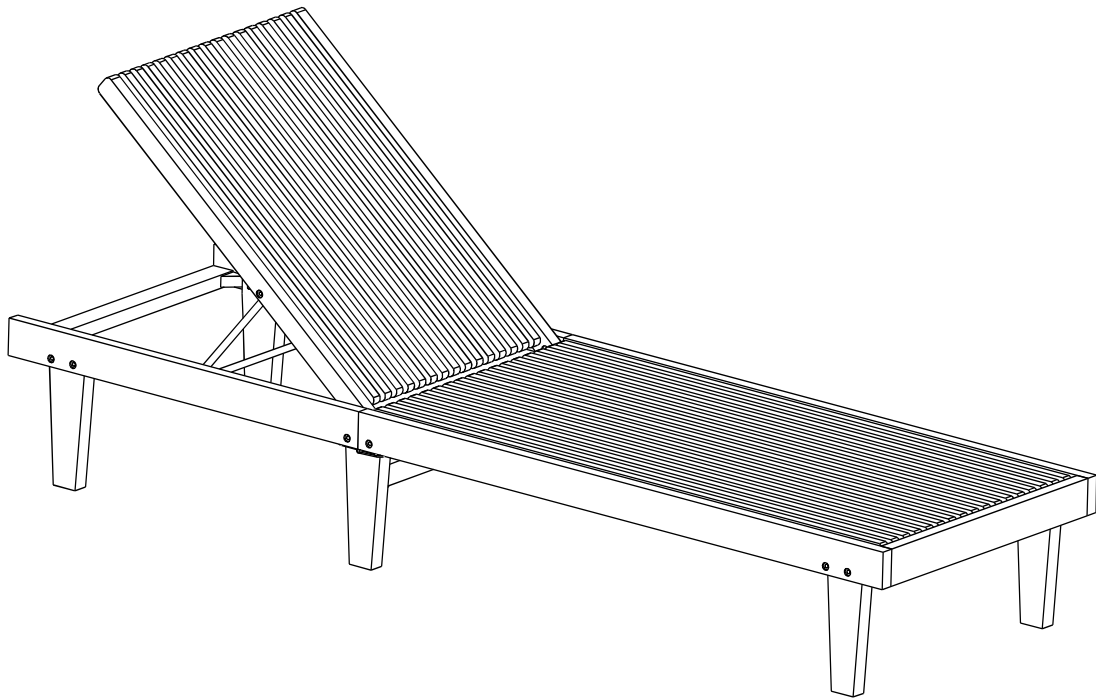

Please look in the Leg for hardware packs

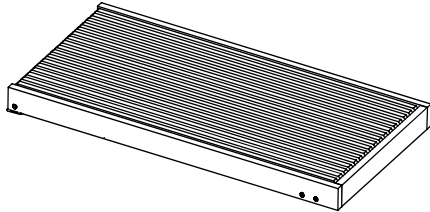
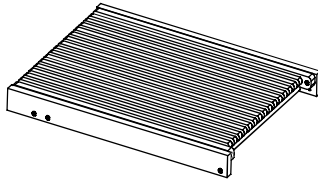
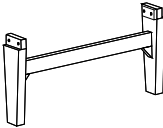
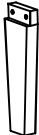

**Caution:** This Lounger is NOT a TOY.  
Keep your child/children at bay during the assembly process.  
Whenever lifting the Lounger and to prevent damage to the Lounger two adults are needed to execute this action.

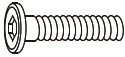
<b>Parts List</b>			
<b>Label</b>	<b>Picture</b>	<b>Description</b>	<b>Qty</b>
A		Seat Panel	1
B		Back Panel	1
C		Middle Leg	1
D		Side Leg	4

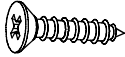
## Hardware

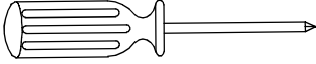
No.	Picture	Description	Qty
①		Bolt (M6 x 45mm)	13
②		Sleeve Nut (M6 x 18mm)	13
③		Screw (M3.5x15mm)	9
④		Hingle	2
⑤		Allen Wrench	2
⑥		Screwdriver	Not provided

# Assembly Preparation

## Before Beginning Assembly:

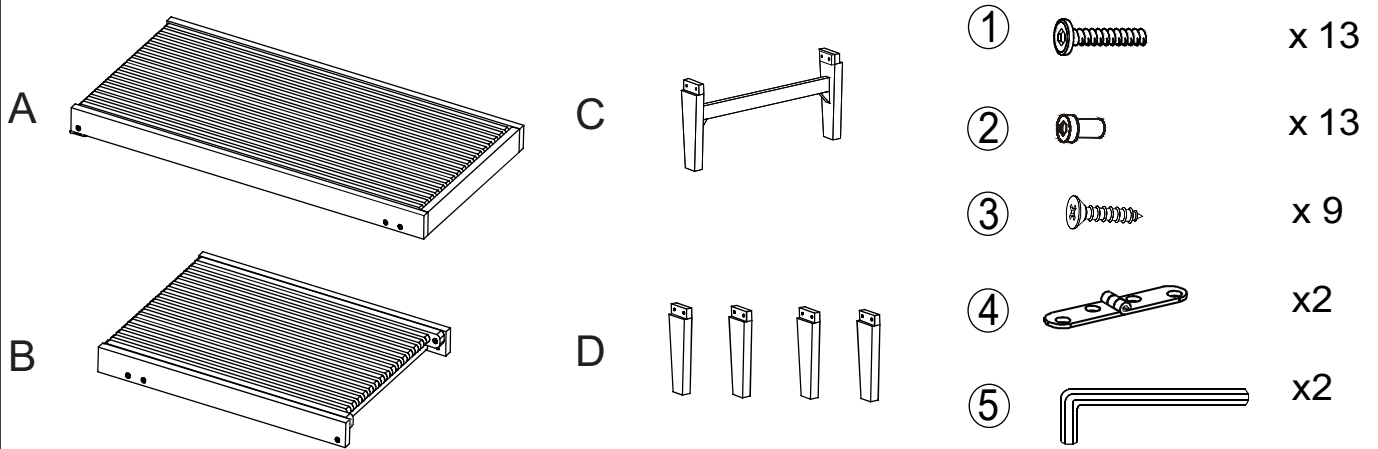

Read instructions, cover to cover.



Have 2 adults on hand for assembly.



Do not assemble on flooring or carpet.



Assemble on a clean non-marring surface (packing foam).



Save all packaging until finished.

## Assembly Steps

### OVERVIEW

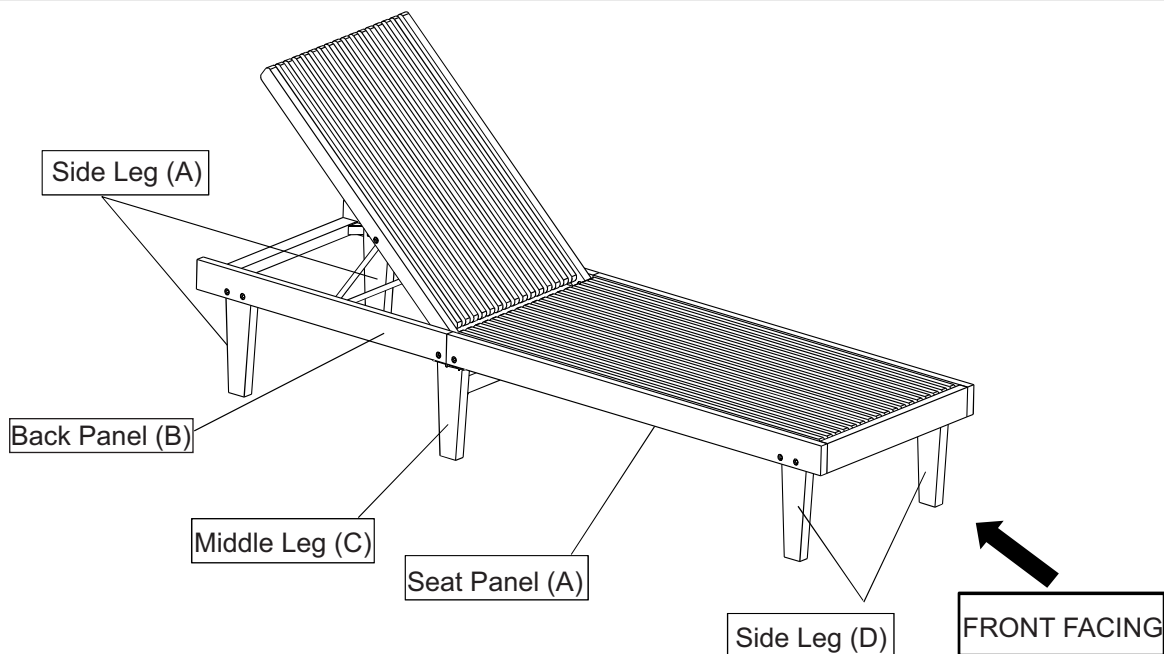

This Lounger has multiple parts and may require up to 30 minutes to assemble. To give you an overview of the Lounger parts, the above picture is to help you put the various parts into perspective. Please read through the instructions below to familiarise yourself with the parts and steps before assembly.

## Assembly Preparation

### Before Beginning Assembly

#### Step 1

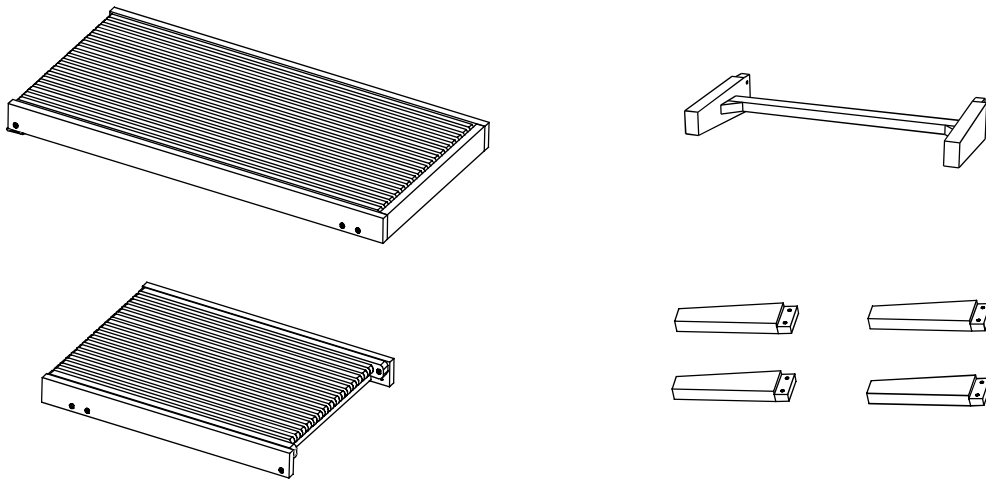

Unpack and place all parts on clean, non-marring surface.

#### Step 2

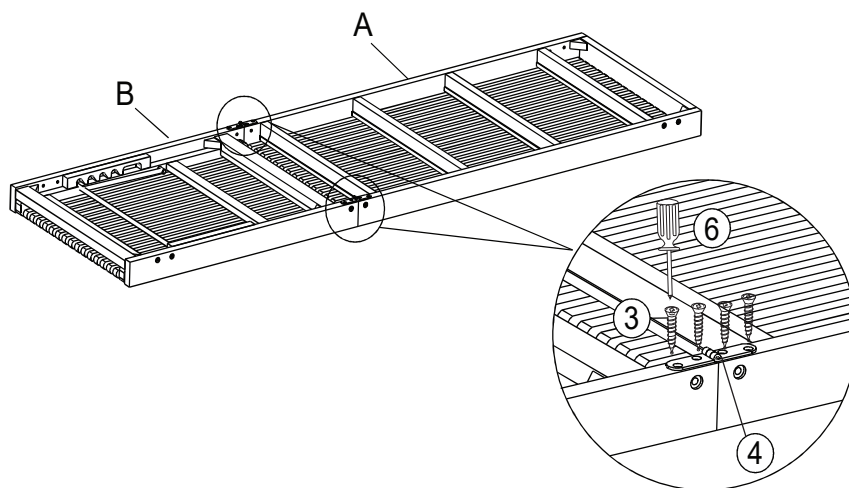

Place the Seat Panel (A) and the Back Panel (B) on the surface as shown above. Attach the Seat Panel (A) to the Back Panel (B) using Screws (3) and Hinges (4) with Screwdriver (6) as shown in the picture above.

**Fully tighten the Screws.**

## Assembly Steps

### Step 3

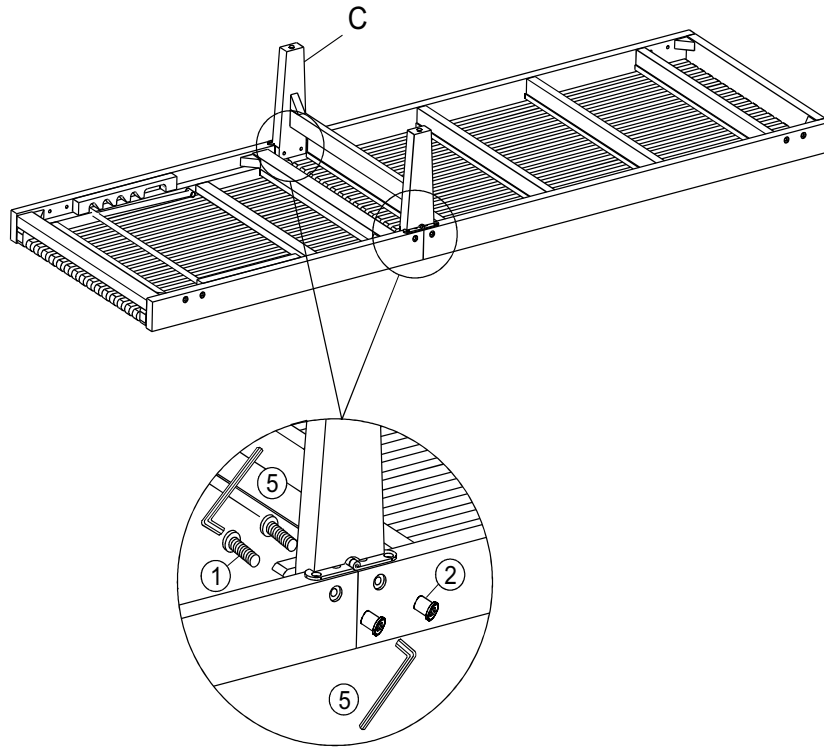

Attach the Middle Leg ( C ) to the Seat Panel (A) and the Back Panel (B) using Bolts (①) and Sleeve Nuts (②) with Allen Wrench (⑤) as picture above.  
**DO NOT fully tighten the Bolts.**

### Step 4

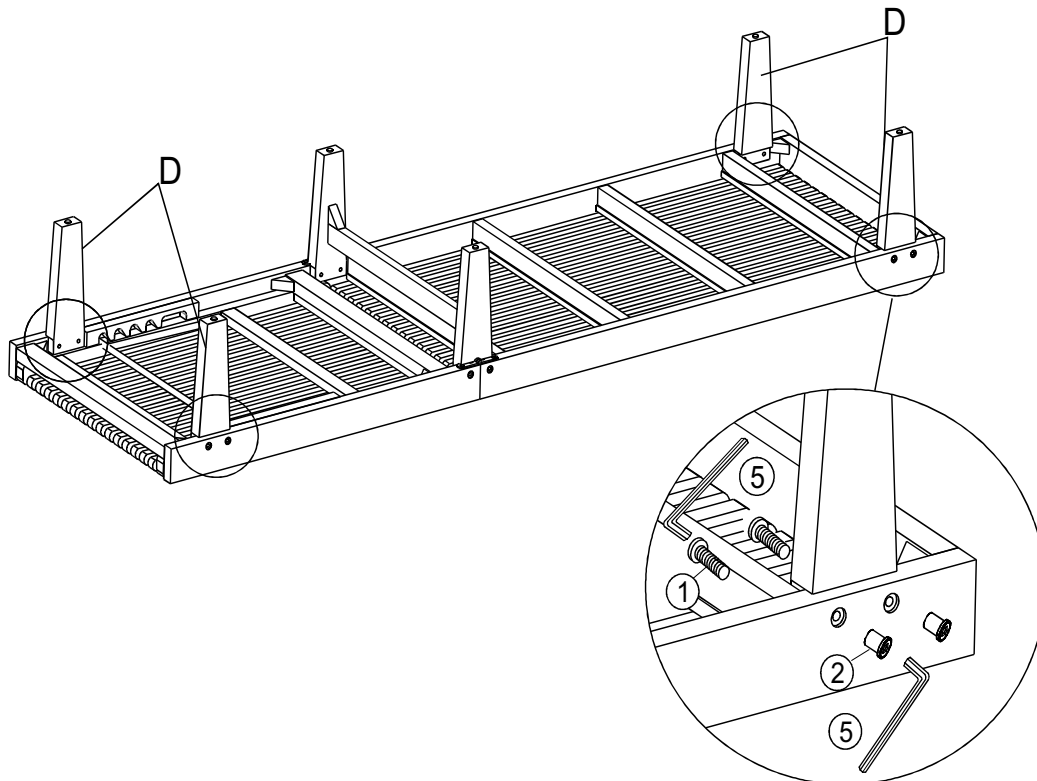

Attach Side Leg (D) to the Seat Panel (A) and the Back Panel (B) using Bolts (①) and Sleeve Nuts (②) with Allen Wrench (⑤).  
Repeat the same process with the remaining three Side Legs (D).  
**DO NOT fully tighten the Bolts.**

## Assembly Steps

### Step 5

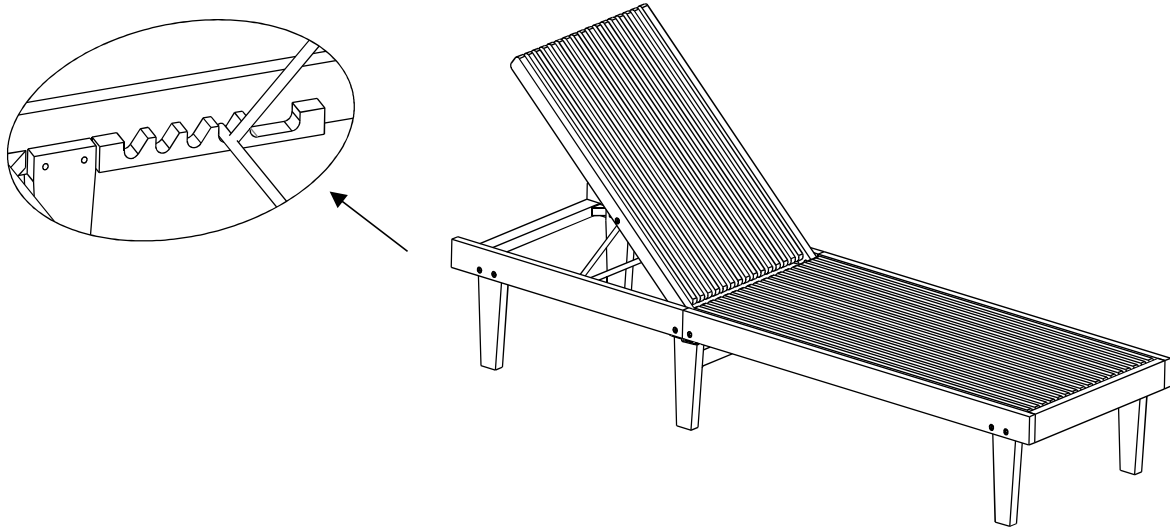

EXERT pressure, floorwards, onto the Seat Panel.

This pressure will help the Legs and Seat Panel reach alignment at all joints.  
Check for wobbles.

In a sequential manner, gradually tighten all Bolts until evenly secured.

Inspect the Lounge and make sure all parts are adequately connected.

Align the Backrest of the Lounge in the position you want as pictured above.

Your Lounge is ready for use.

This Lounge can only be used on a flat, level surface.