

Nightstand

Assembly Instructions - Please keep for future reference

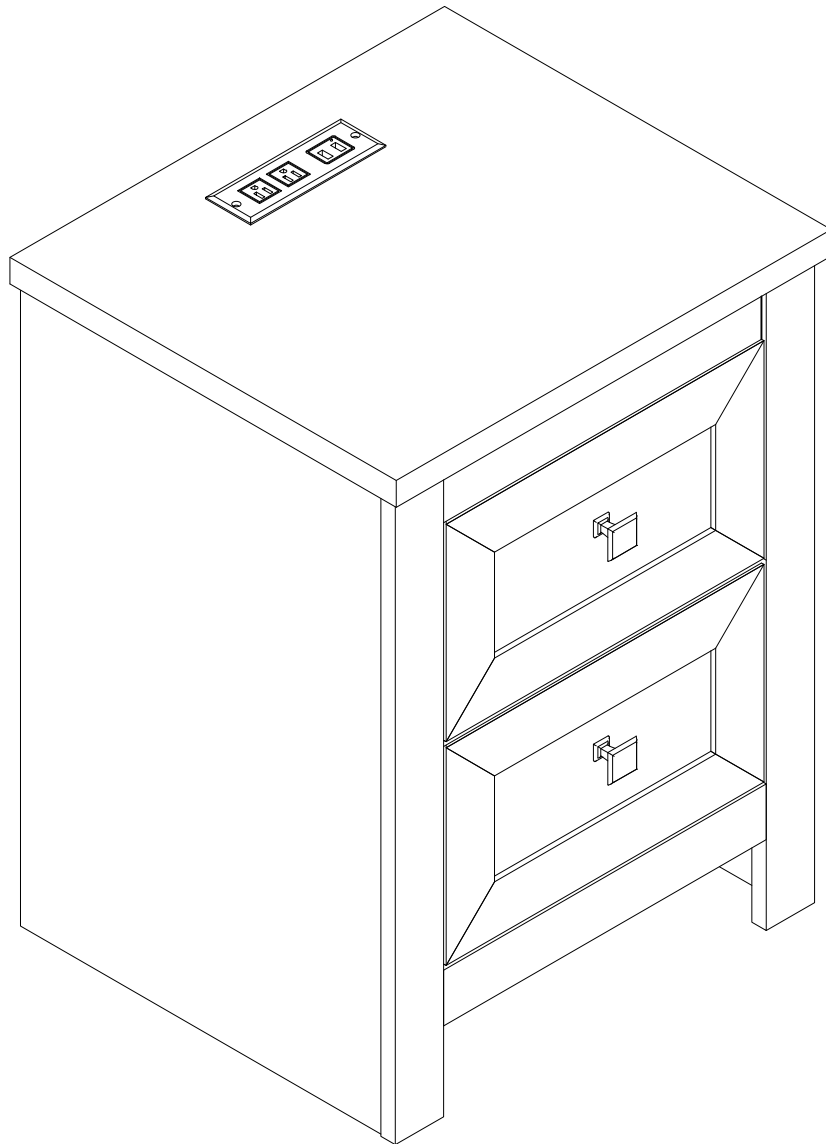

Dimensions

Width - 450mm

Depth - 400mm

Height - 610mm

Important – Please read these instructions fully before starting assembly



Safety and Care Advice

Important – Please read these instructions fully before starting assembly

- Check you have all the components and tools listed on the following pages.
- Remove all fittings from the plastic bags and separate them into their groups.
- Keep children and animals away from the work area, small parts could choke if swallowed.
- Make sure you have enough space to layout the parts before starting.

- During assembly do not stand or put weight on the product, this could cause damage.
- Assemble the item as close to its final position (in the same room) as possible.
- Assemble on a soft level surface to avoid damaging the unit or your floor.
- Parts of the assembly will be easier with 2 people.



power drill is set on a low torque setting.

- To reduce the likelihood of damaging your product please ensure that your

Care and maintenance

- Only clean using a damp cloth and mild detergent, do not use bleach or abrasive cleaners.
- From time to time check that there are no loose screws on this unit.
- This product should not be discarded with household waste. Take to your local authority waste disposal centre.

Handy Hints

- Assemble all parts and bolts loosely during assembly, only once the product is complete should you fully tighten the bolts
- Regularly check and ensure That all bolts and fittings are tightend properly.

Components - Panels

Please check you have all the panels listed below

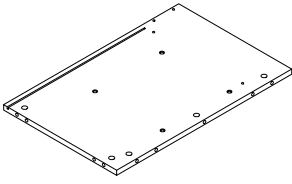

1 (580X375X15mm)X1

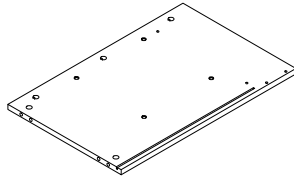

2 (580X375X15mm)X1

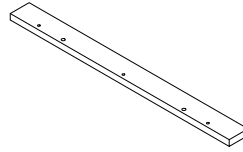

3 (580X50X15mm)X1

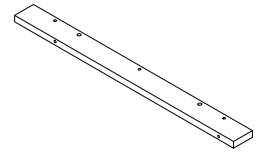

4 (580X50X15mm)X1

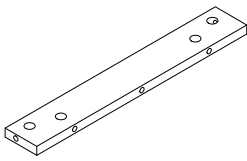

5 (400X60X15mm)X1

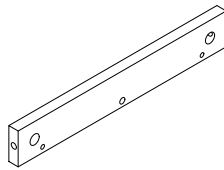

6 (334X50X15mm)X1

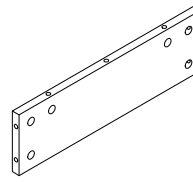

7 (400X116X15mm)X1

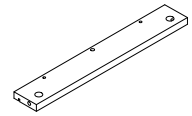

8 (400X60X15mm)X1

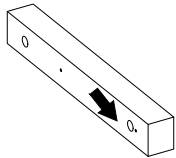

9 (300X40X33mm)X4

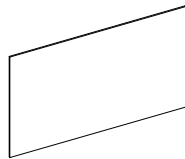

10 (410X229X3mm)X1

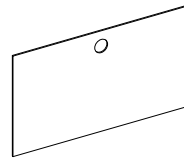

11 (410X229X3mm)X1

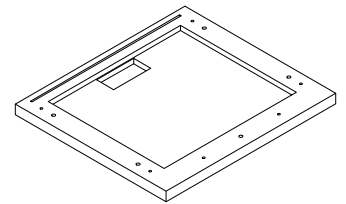

12 (450X400X25mm)X1

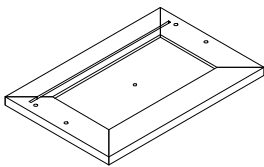

13 (328X195X15mm)X2

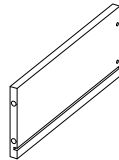

14 (300X118X12mm)X2

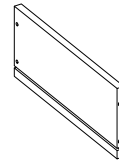

15 (300X118X12mm)X2

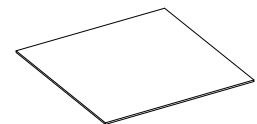

16 (295X297X3mm)X2

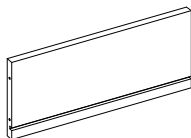

17 (285X118X12mm)X2

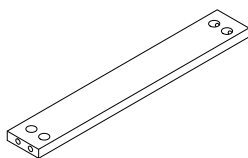

18 (400X60X15mm)X1

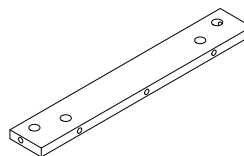











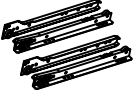

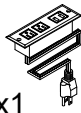
19 (334X50X15mm)X1

Components - Fittings

Please check you have all the panels listed below

Note: The quantities below are the correct amount to complete the assembly. In some cases more fittings may be supplied than are required.

A  Male Camlock x 40	B  Female Camlock x 40	C  Dowel x 11
D  Drawer slider 12" X 2	E  3*12mm Screw x 16	F  Socket x1
G  Handle & Fixings x 2	H  4*30mm Screw x 8	I  Protective Feet x 6
J  3*17mm Screw x 6	K  Plastic wedge x 6	L  3.5*14mm Screw x 2
M  6*35mm Screw x 8	N  399mm Screw x 1	

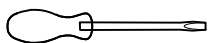

Tools required

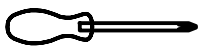

Phillips screwdriver
(medium & large)

Ruler - Use this ruler to help correctly identify the screws

0 5 10 15 20 25 30 35 40 45 50 55 60 65 70 75 80 85 90 95 100 105 110 115 120 125 130 135 140 145 150 155 160 165 170



The screws length is measured from the head to the point (35mm screw shown).

Using Camlocks

Step 1

Connect the male camlock as directed in the assembly instructions using a screwdriver.

1

DO NOT OVER TIGHTEN.
NE PAS SERRER EXCESSIVEMENT.

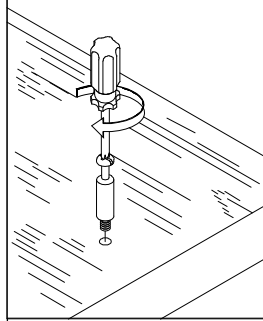

Step 2

Push the male camlock into the entry hole.

2

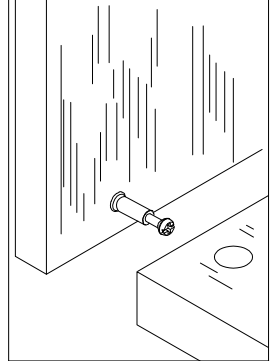

Step 3

Insert the female camlock as shown in the instruction.

Note: ensure that the arrow on the top of the camlock points towards the entry hole for the male camlock.

3

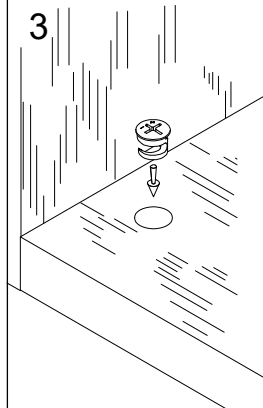

Step 4

Turn the female camlock clockwise with a screwdriver.

You should feel a click when the camlock is locked in place.

The joint is now secure.

4

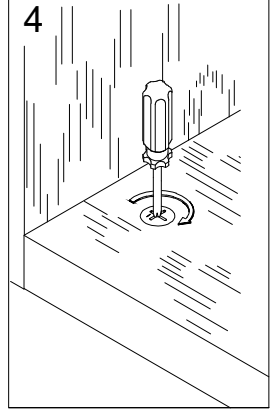

Assembly Instructions

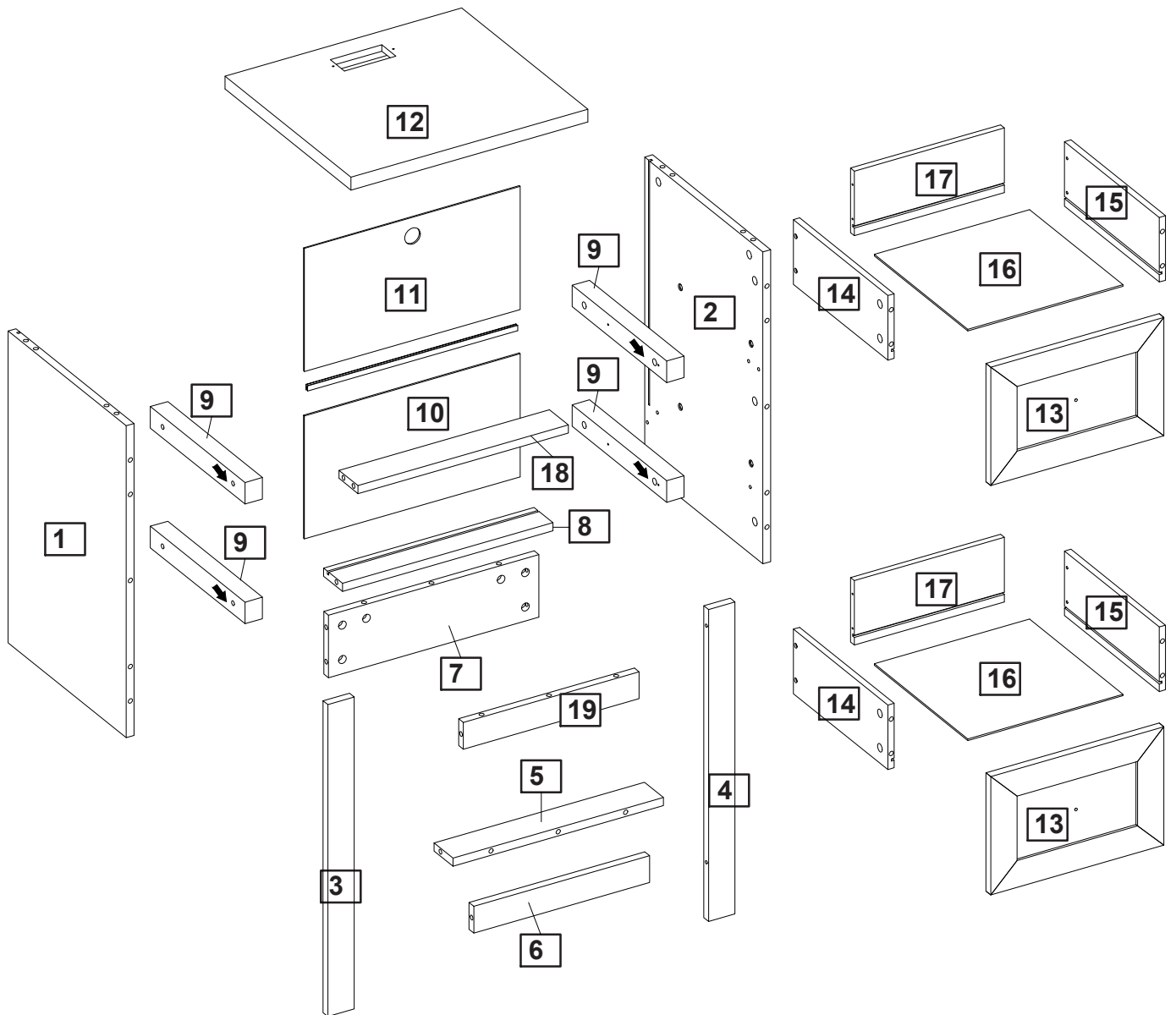

Assembly Instructions

Step 1

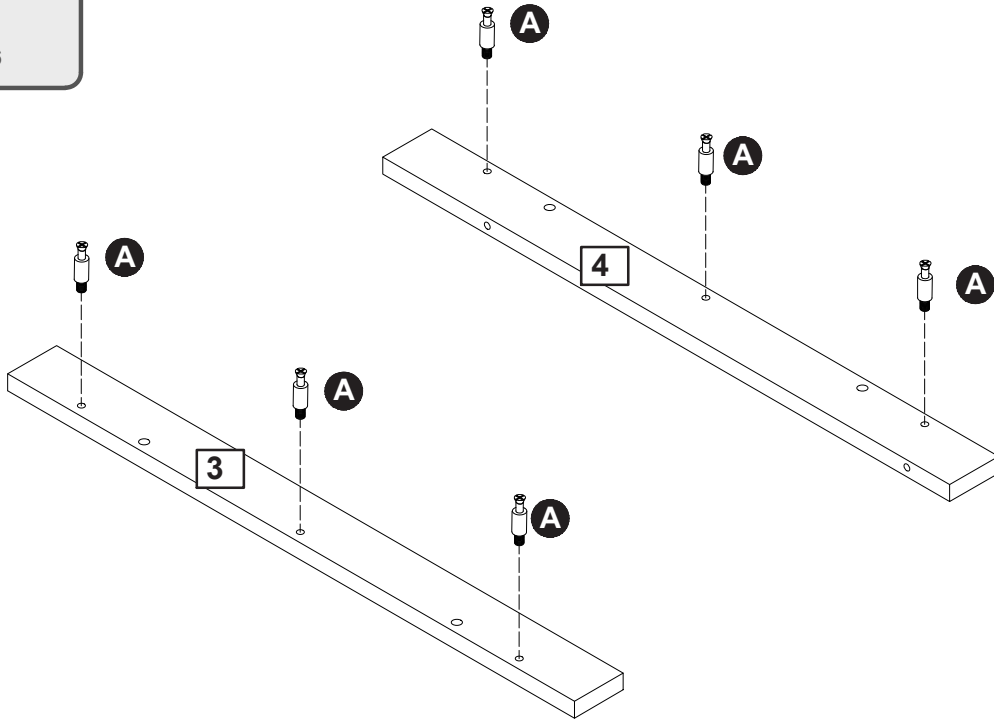
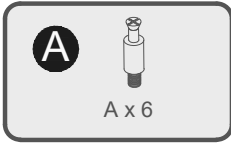

Step 2

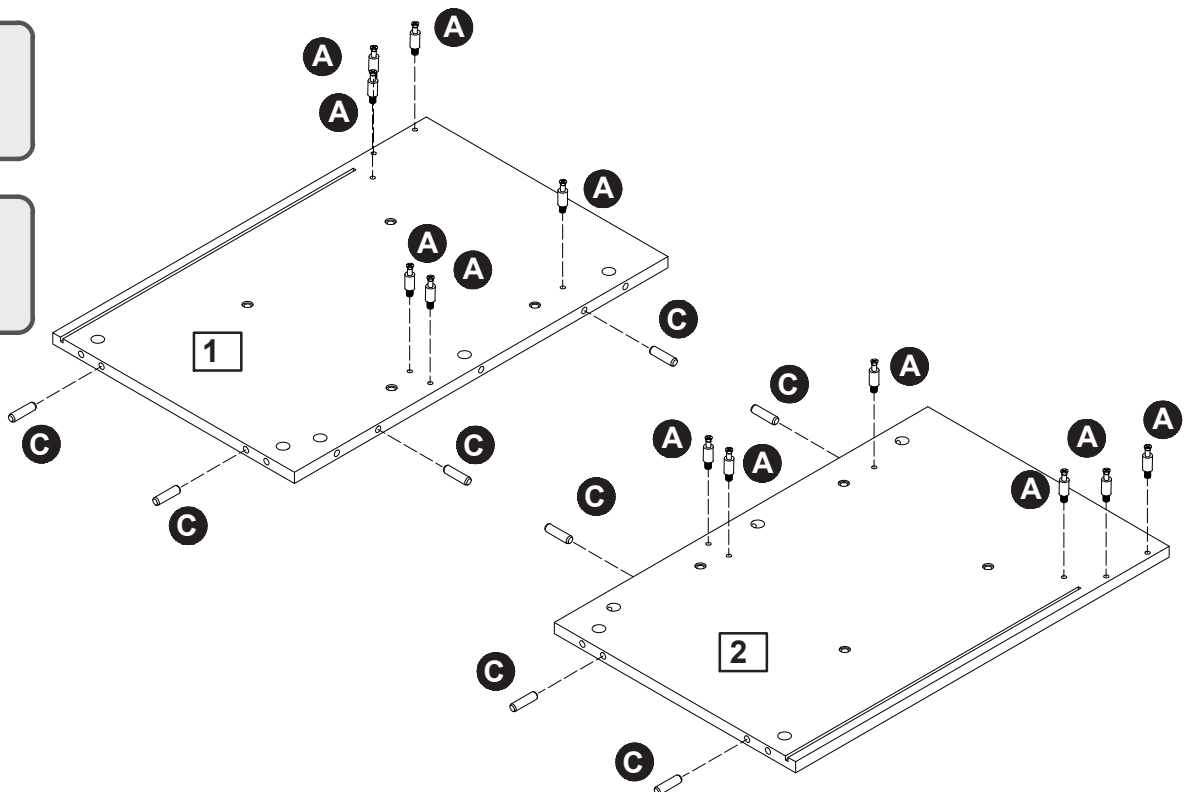
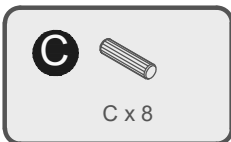
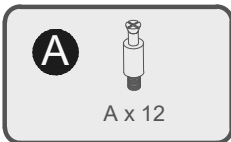

Assembly Instructions

Step 3

B



B x 3

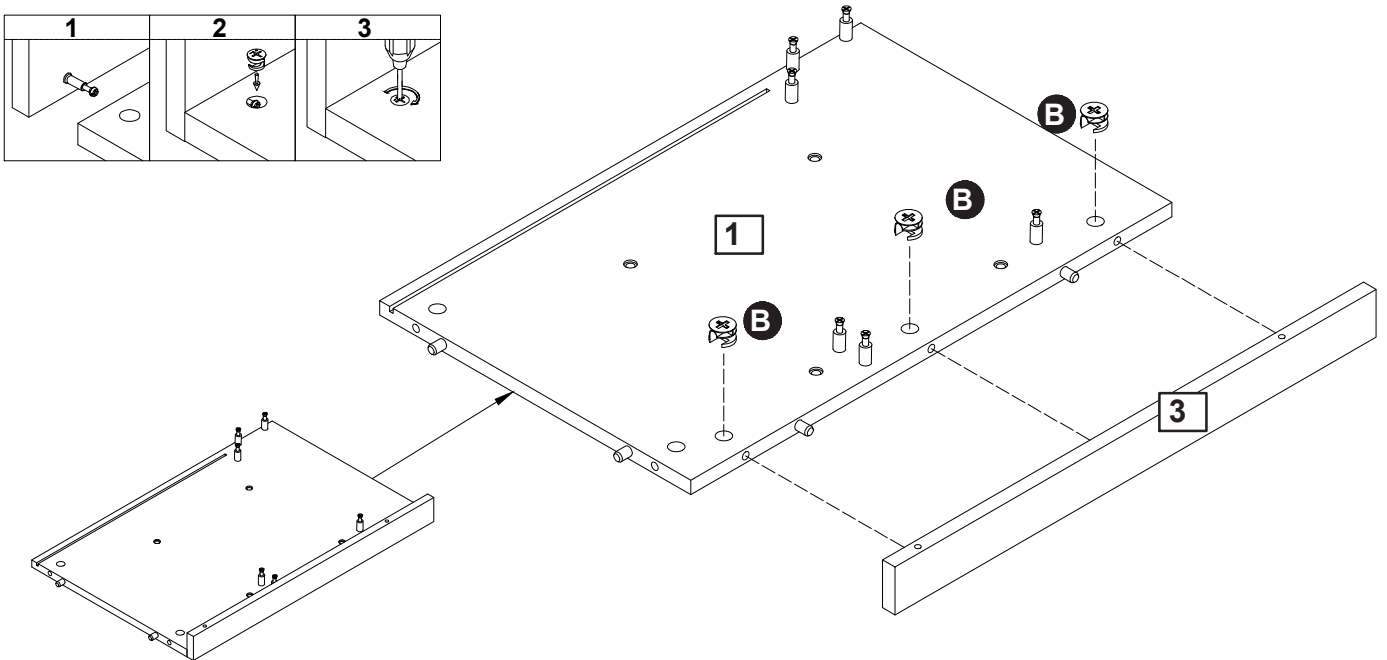
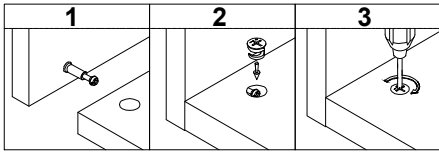

Step 4

B



B x 3

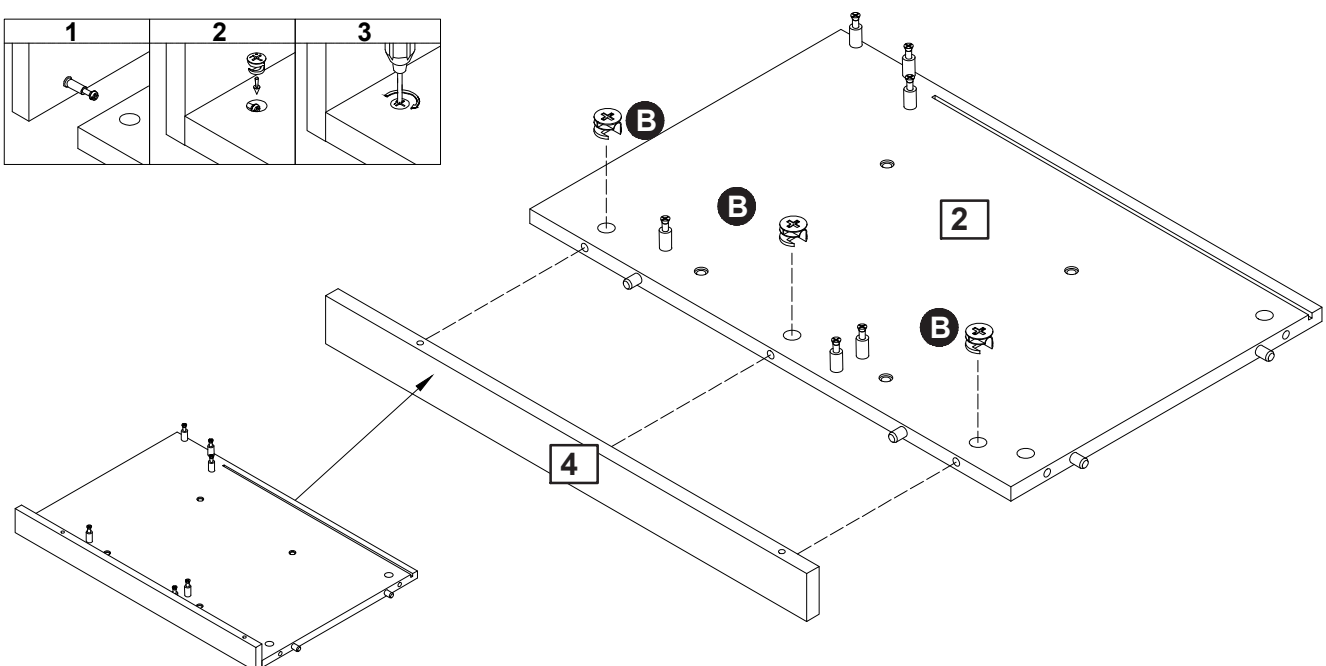
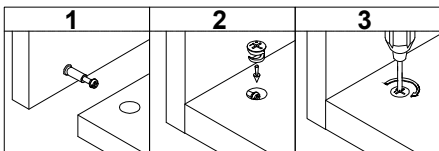

Assembly Instructions

Step 5

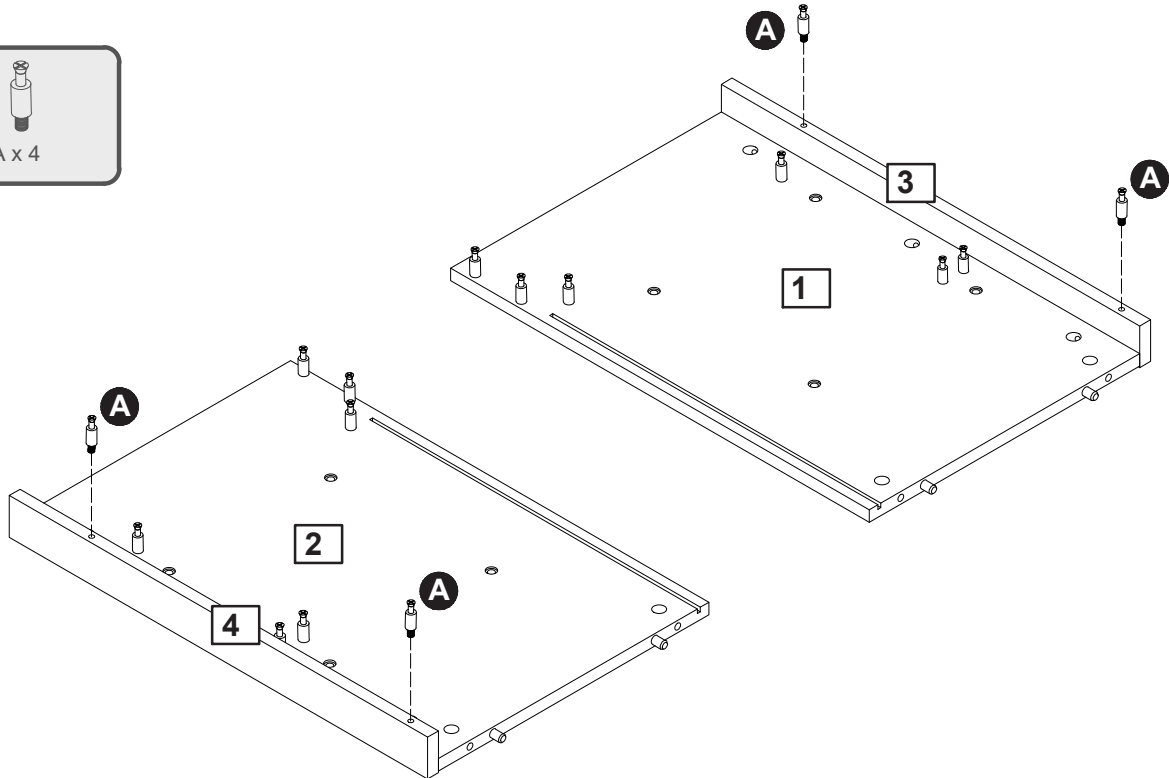
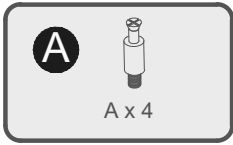

Step 6

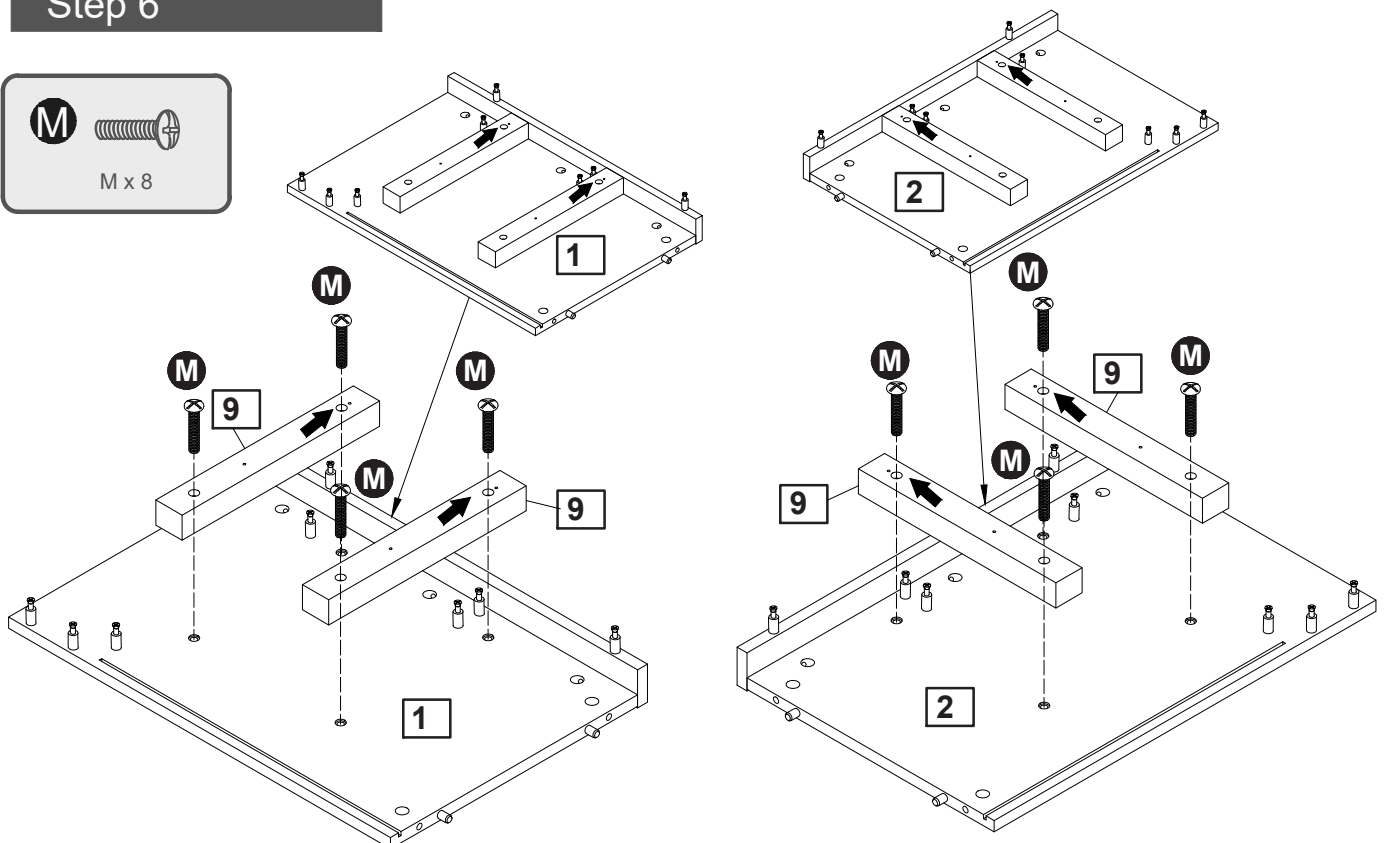

Assembly Instructions

Step 7

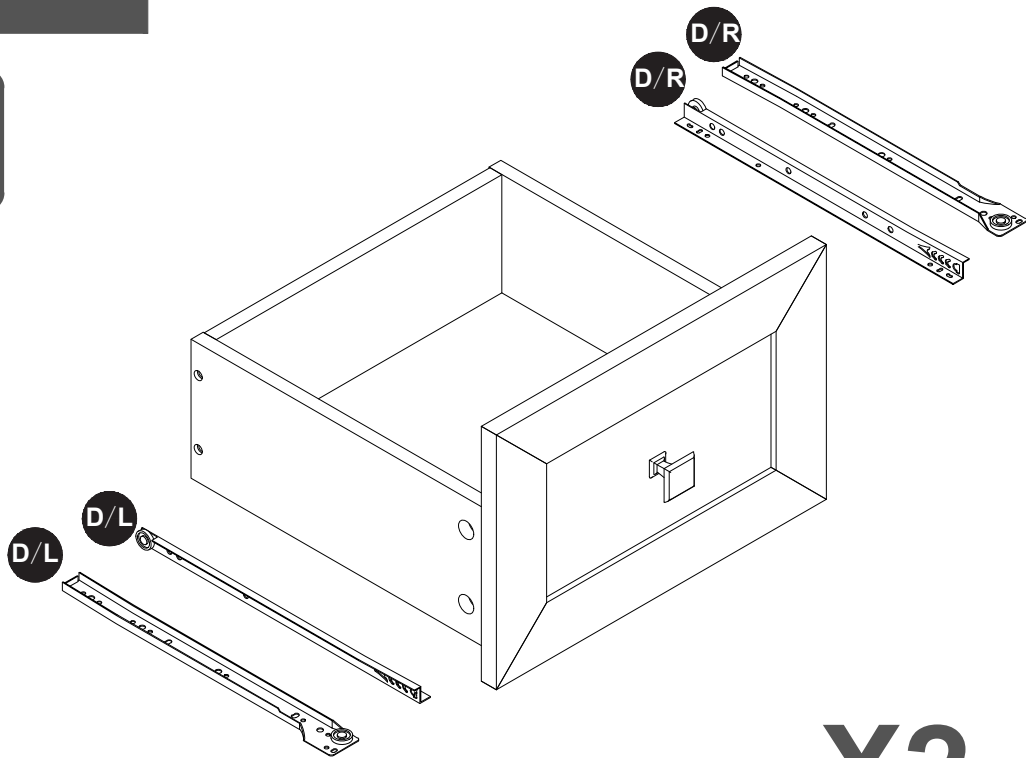
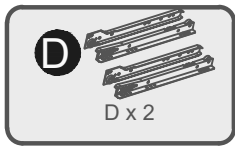

reminder: sort out left and right sliding rails before installing is recommended

Step 8

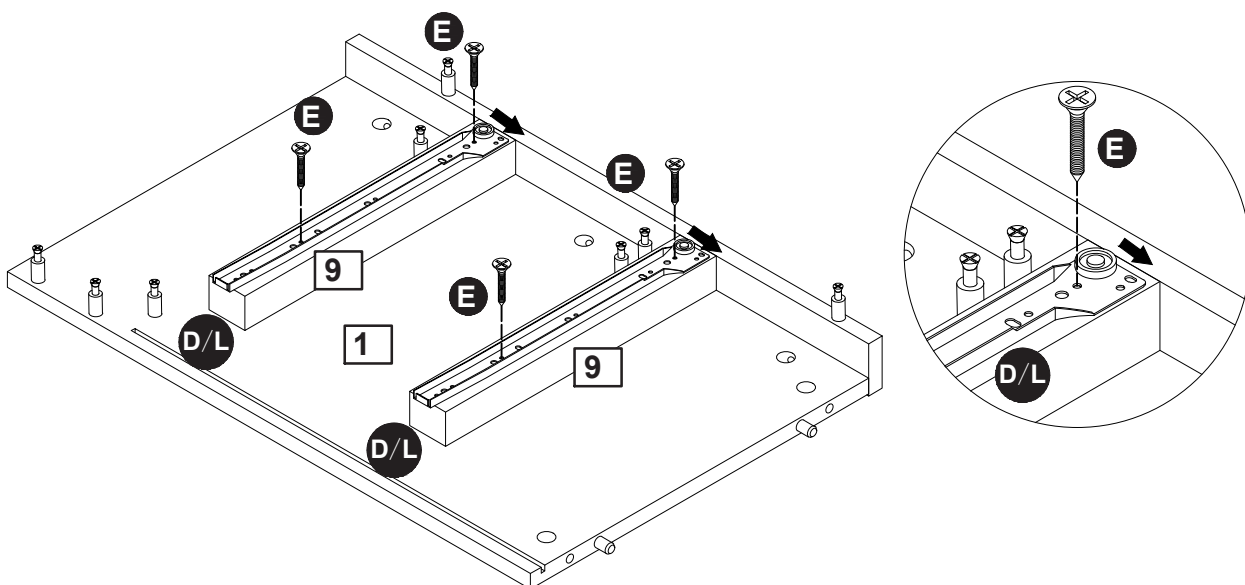

Assembly Instructions

Step 9

E

E x 4

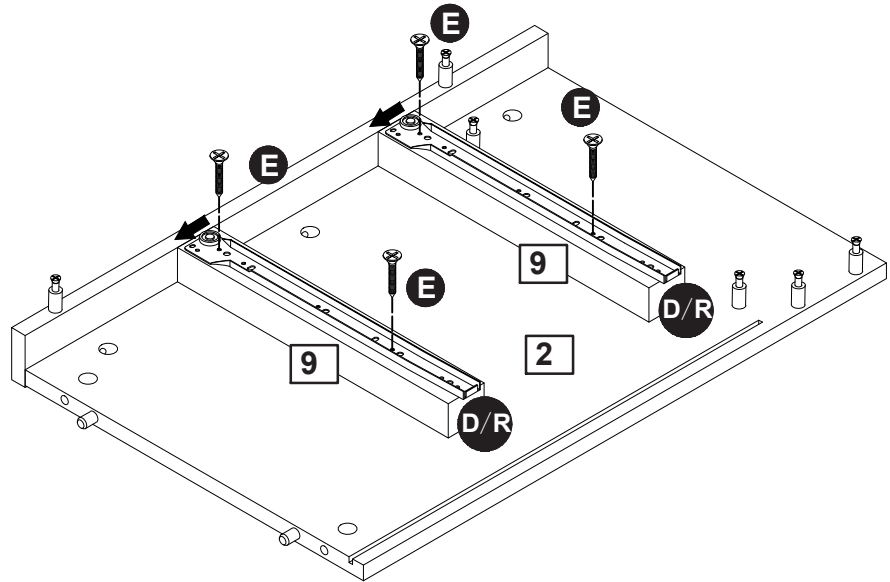
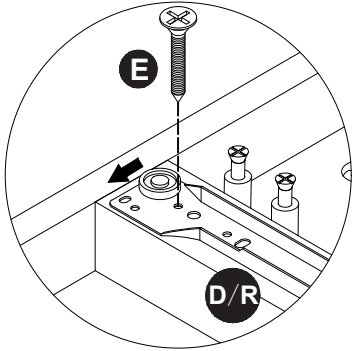

Step 10

A

A x 2

C

C x 2

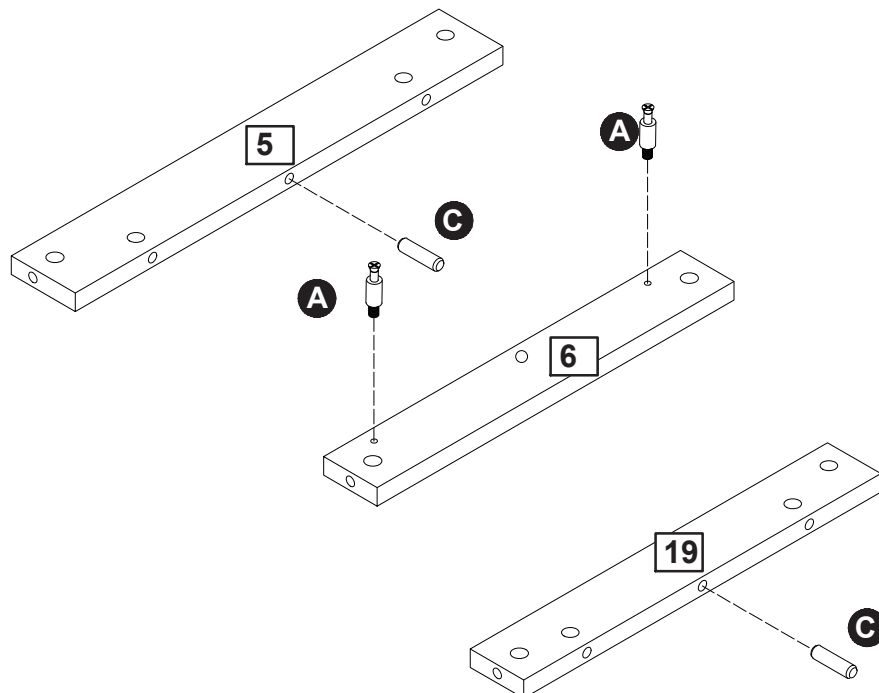

Assembly Instructions

Step 11

B

B x 2

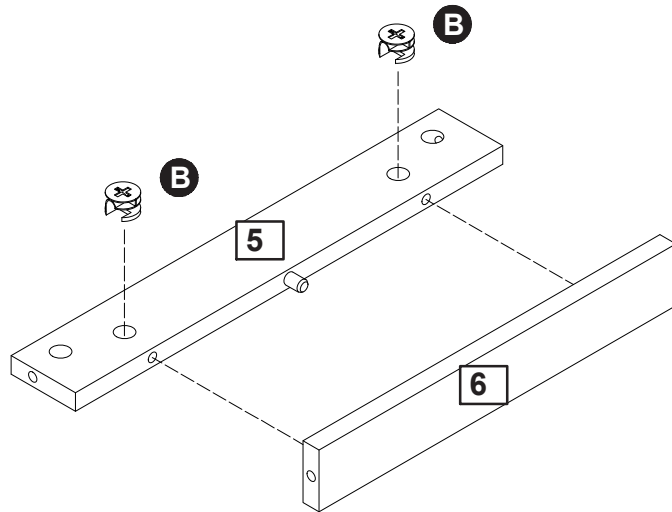
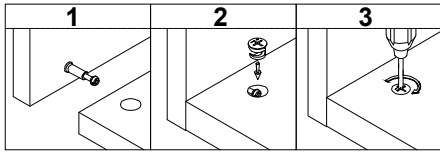

Step 12

A

A x 2

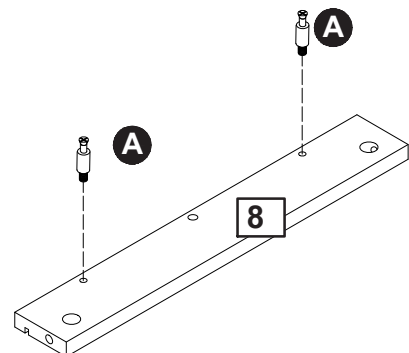
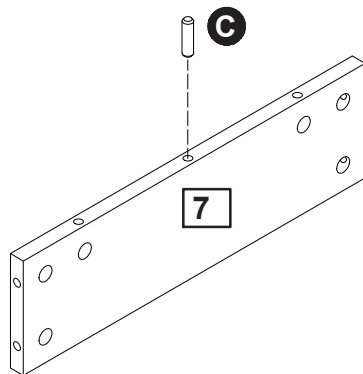
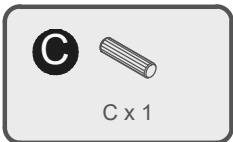

Assembly Instructions

Step 13

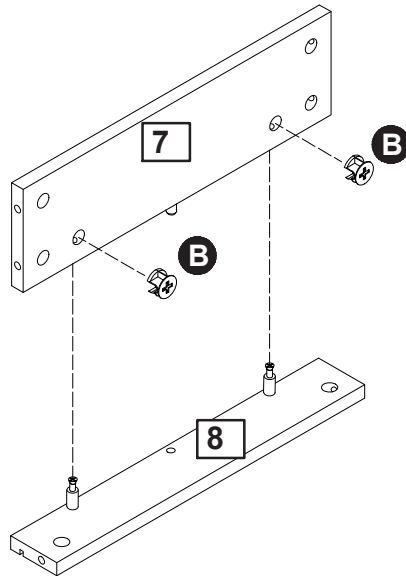
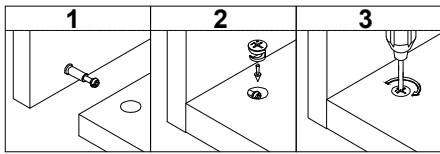

Step 14

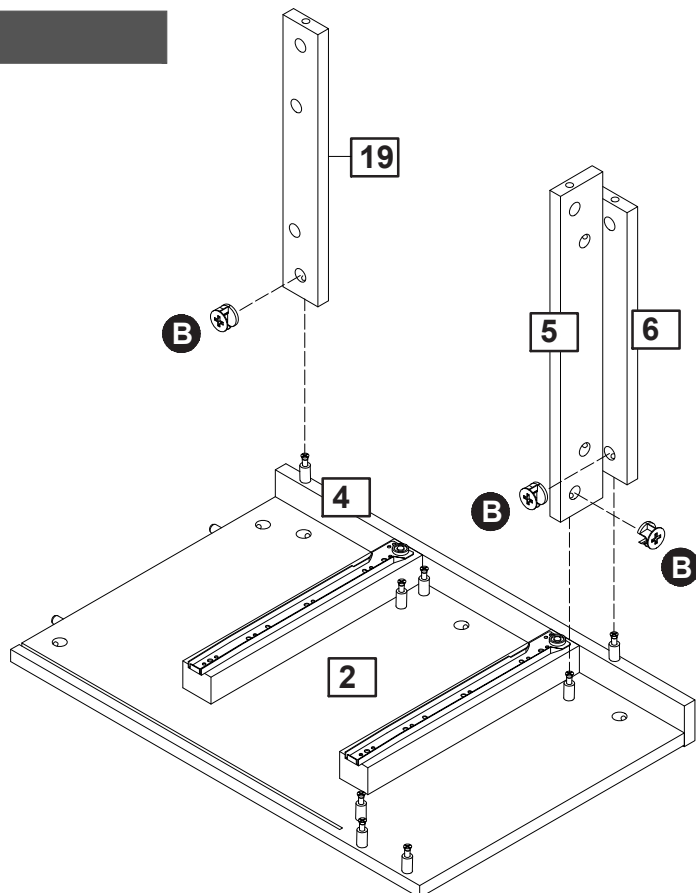
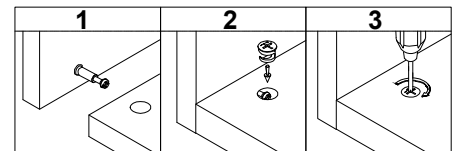

Assembly Instructions

Step 15

B



B x 5

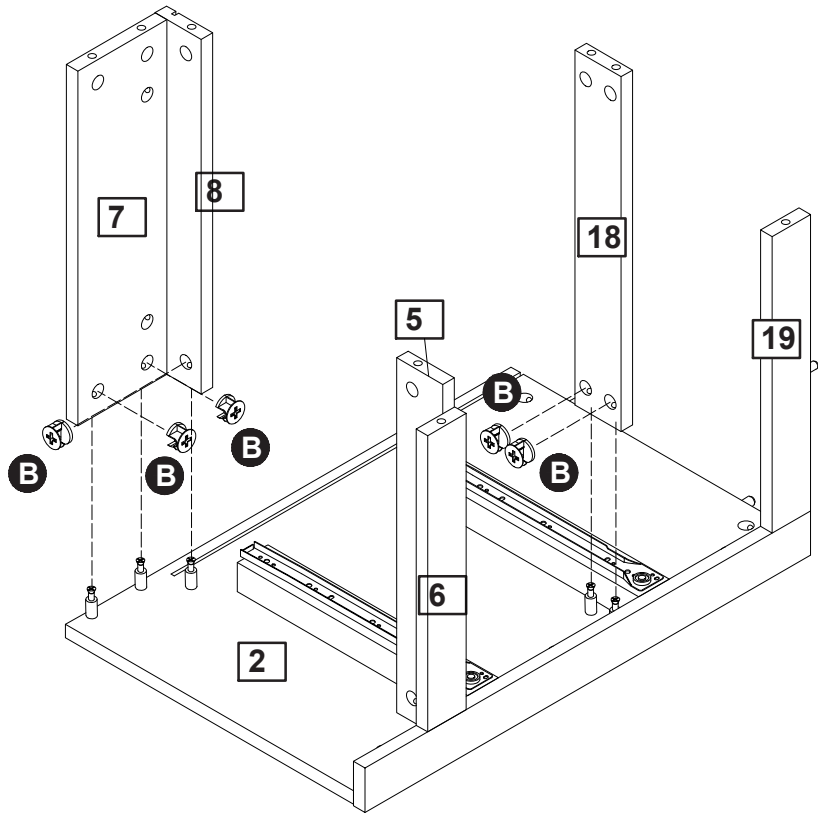
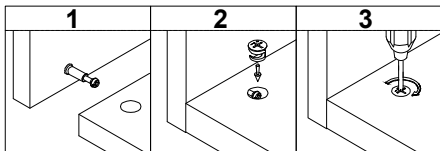

Step 16

B



B x 8

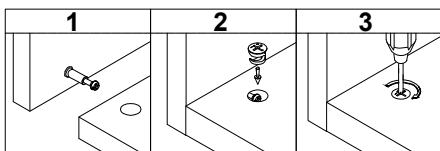

I



I x 6

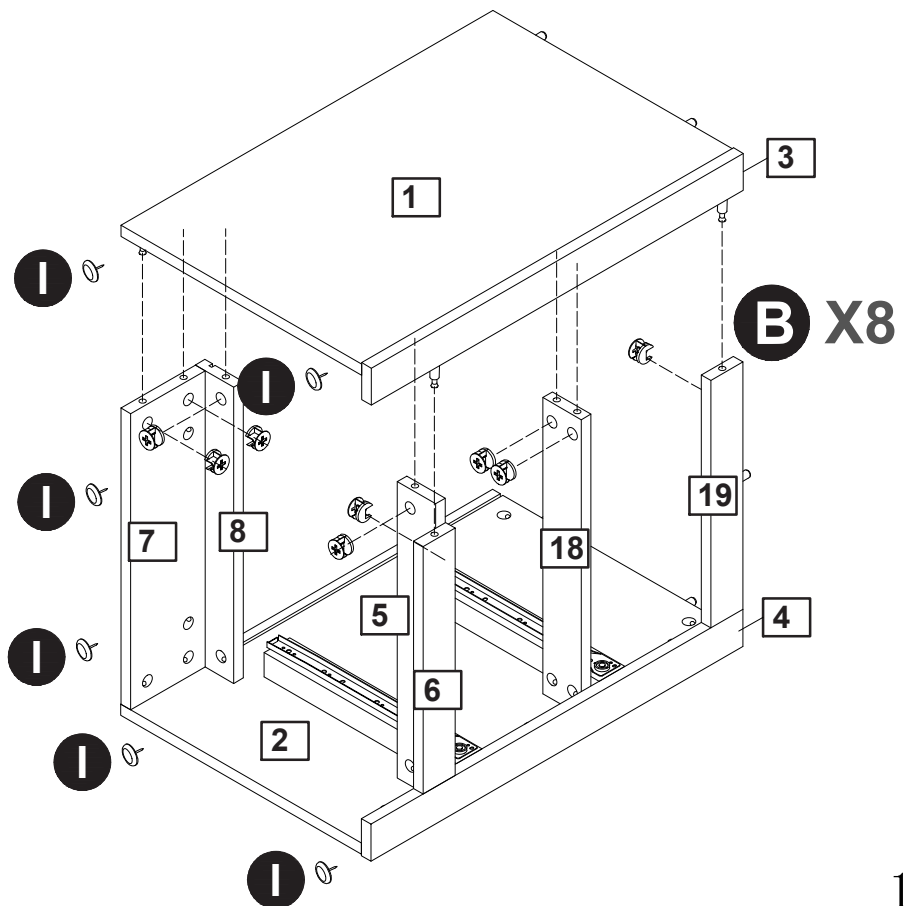

Assembly Instructions

Step 17

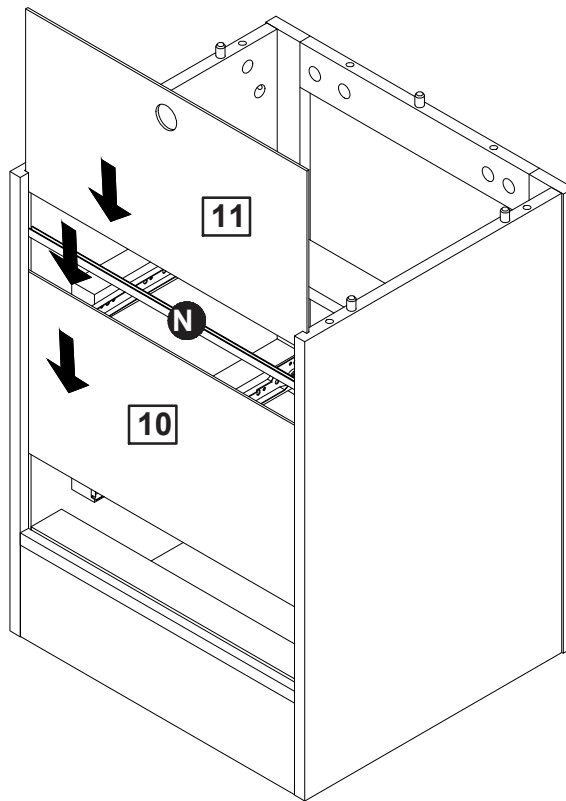
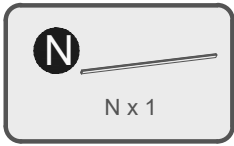

Step 18

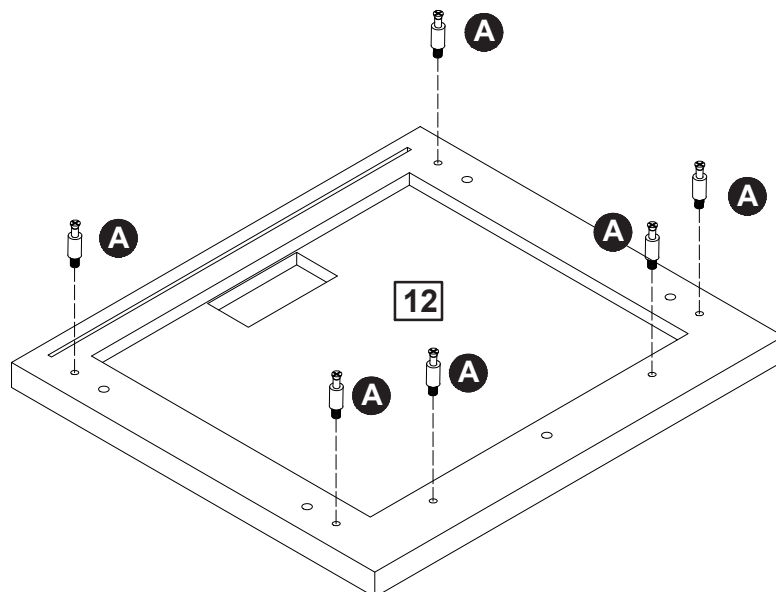
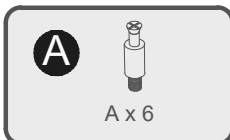

Assembly Instructions

Step 19

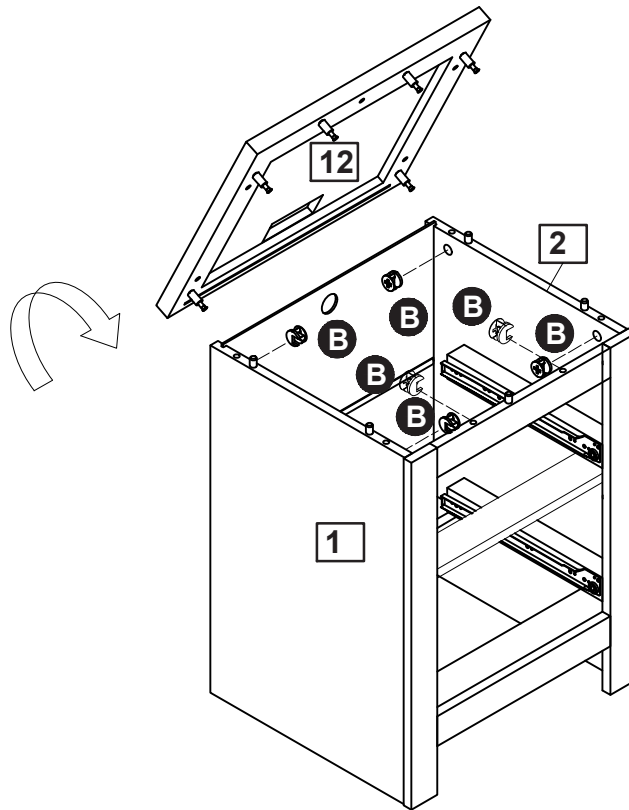
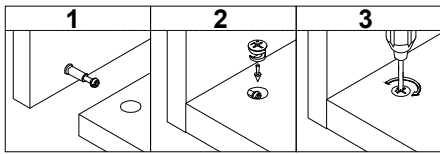

Step 20

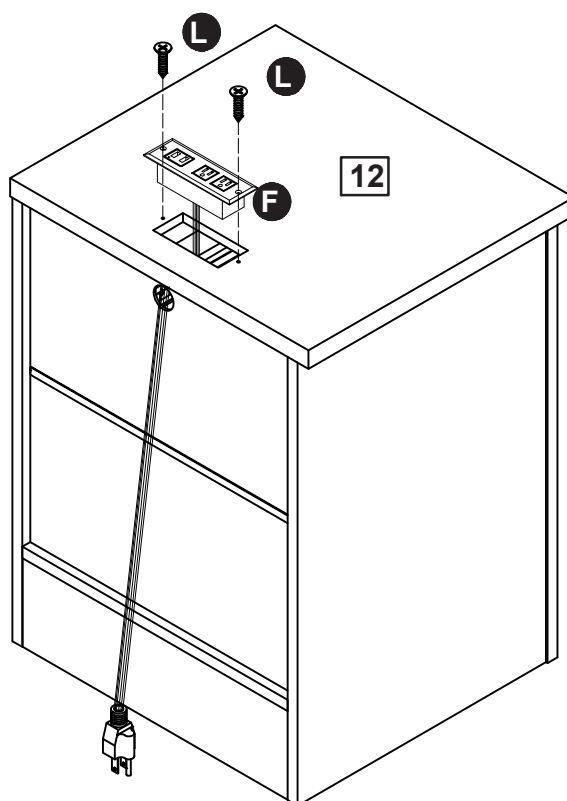
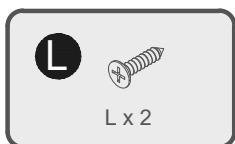

Assembly Instructions

Step 21

J



J x 6

K



K x 6

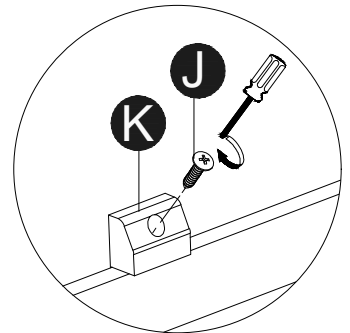
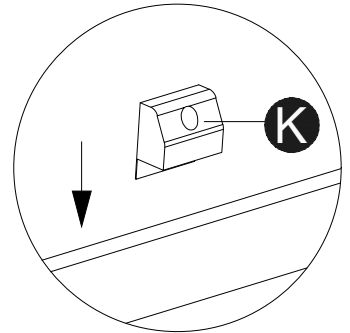
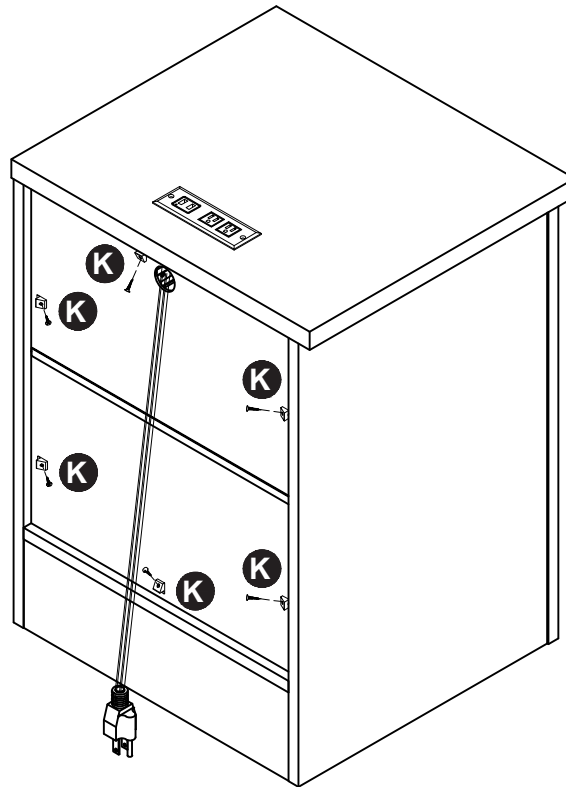

Step 22

A



A x 8

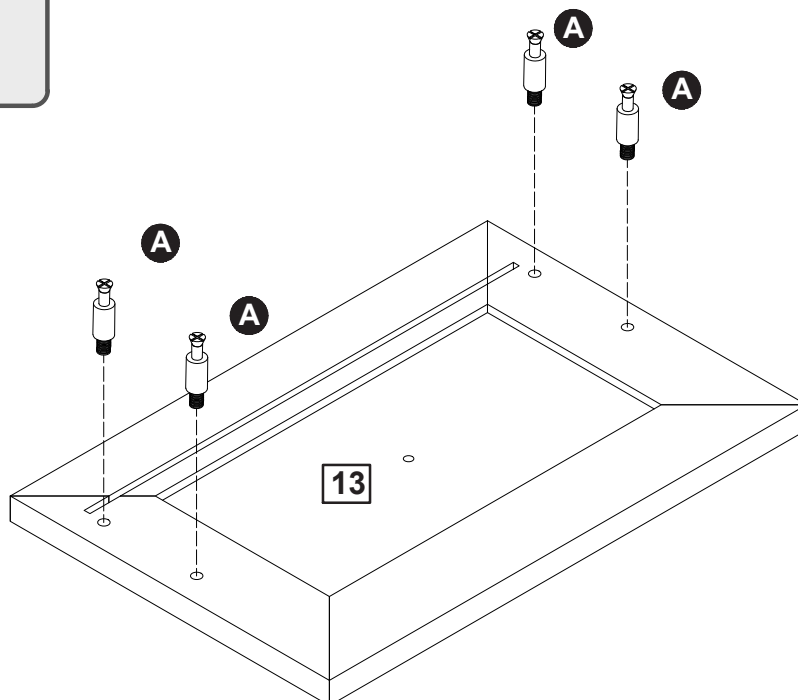

X2

Assembly Instructions

Step 23

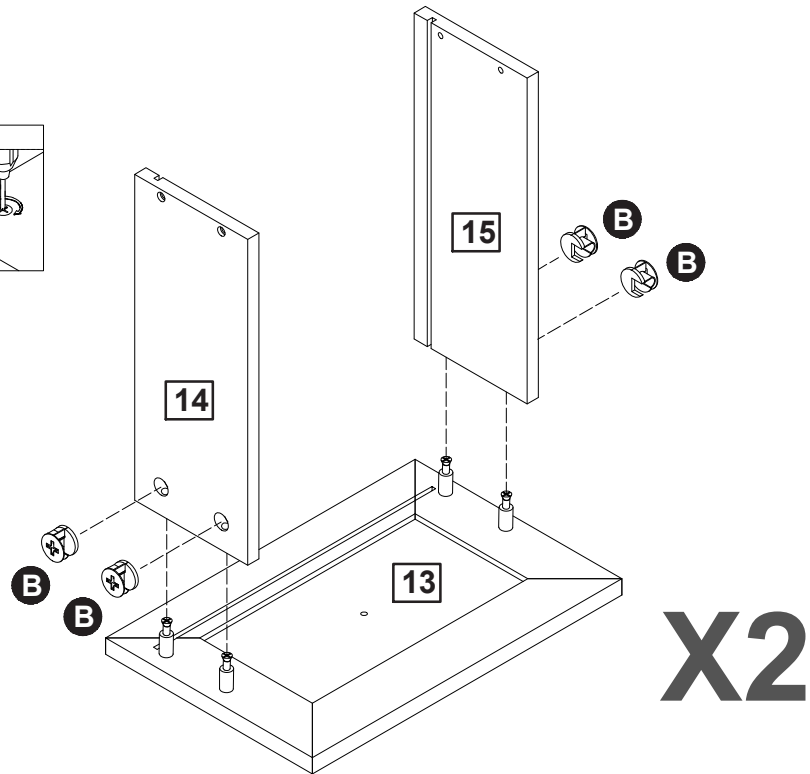
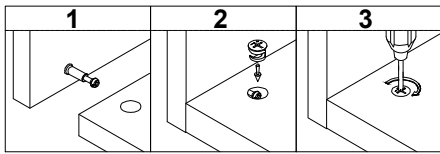

Step 24

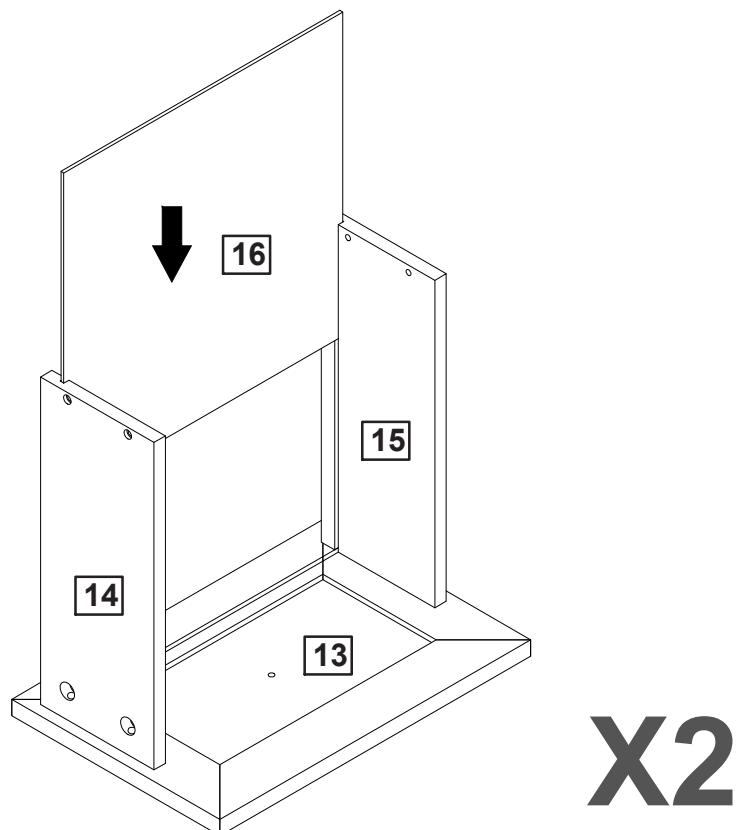

Assembly Instructions

Step 25

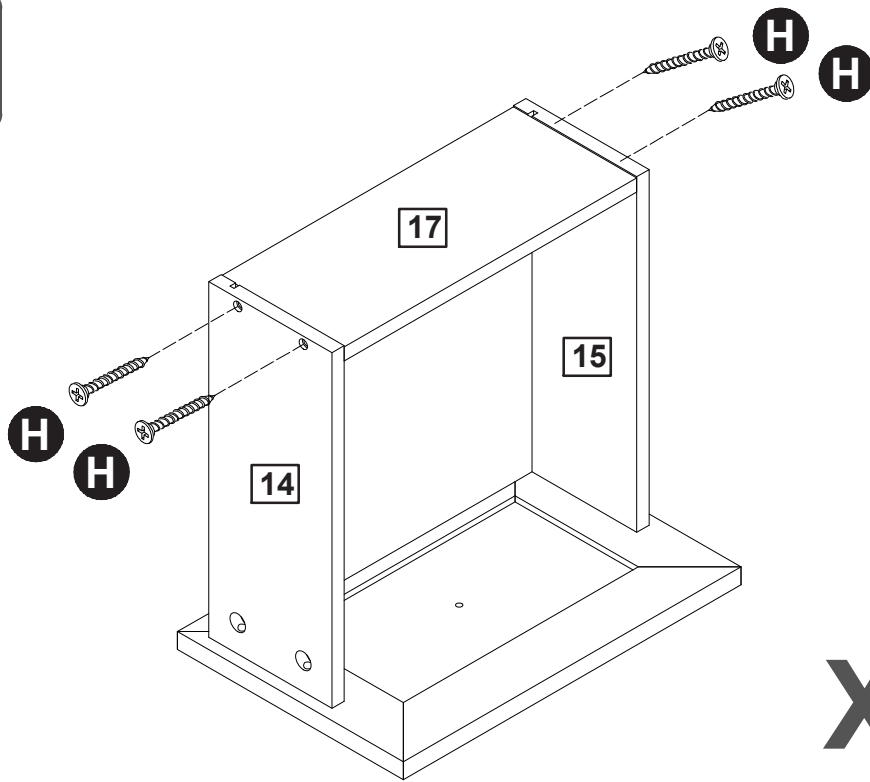
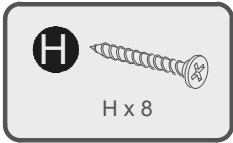

X2

Step 26

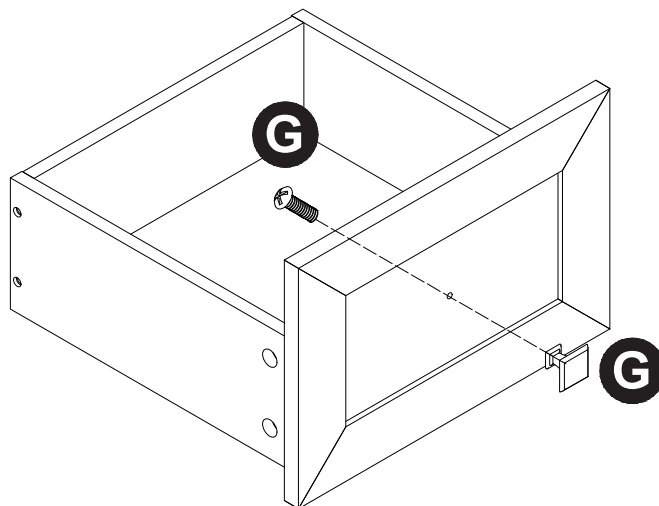
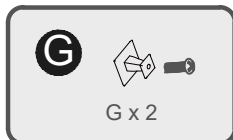

X2

Assembly Instructions

Step 27

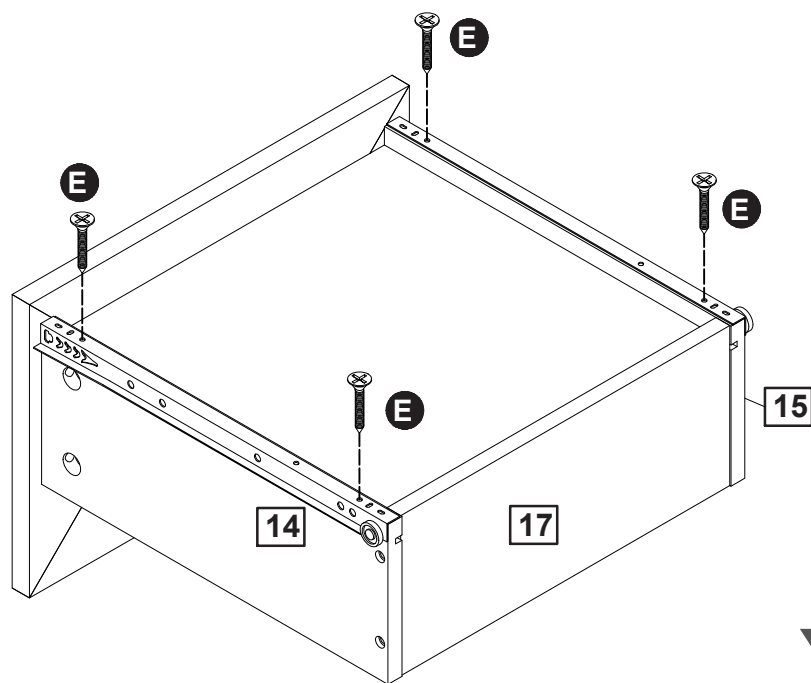

X2

Step 28

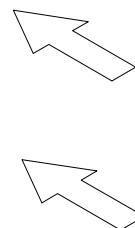
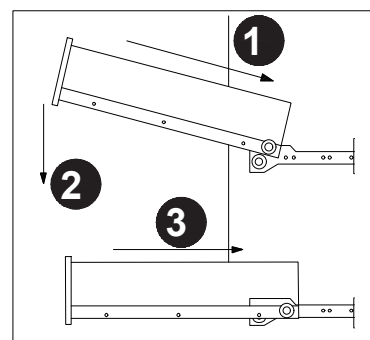
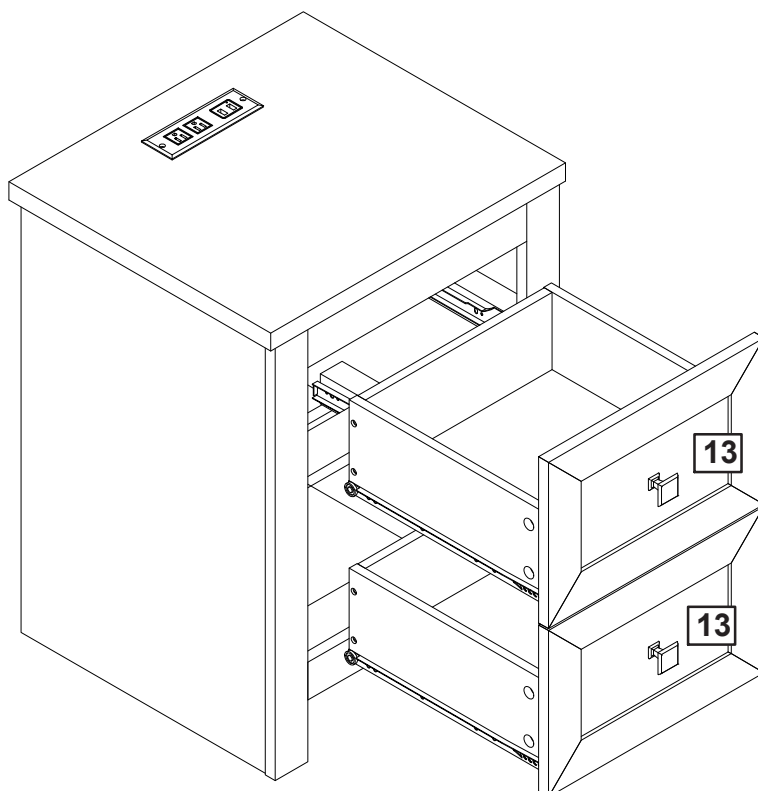

Assembly Instructions

Step 29

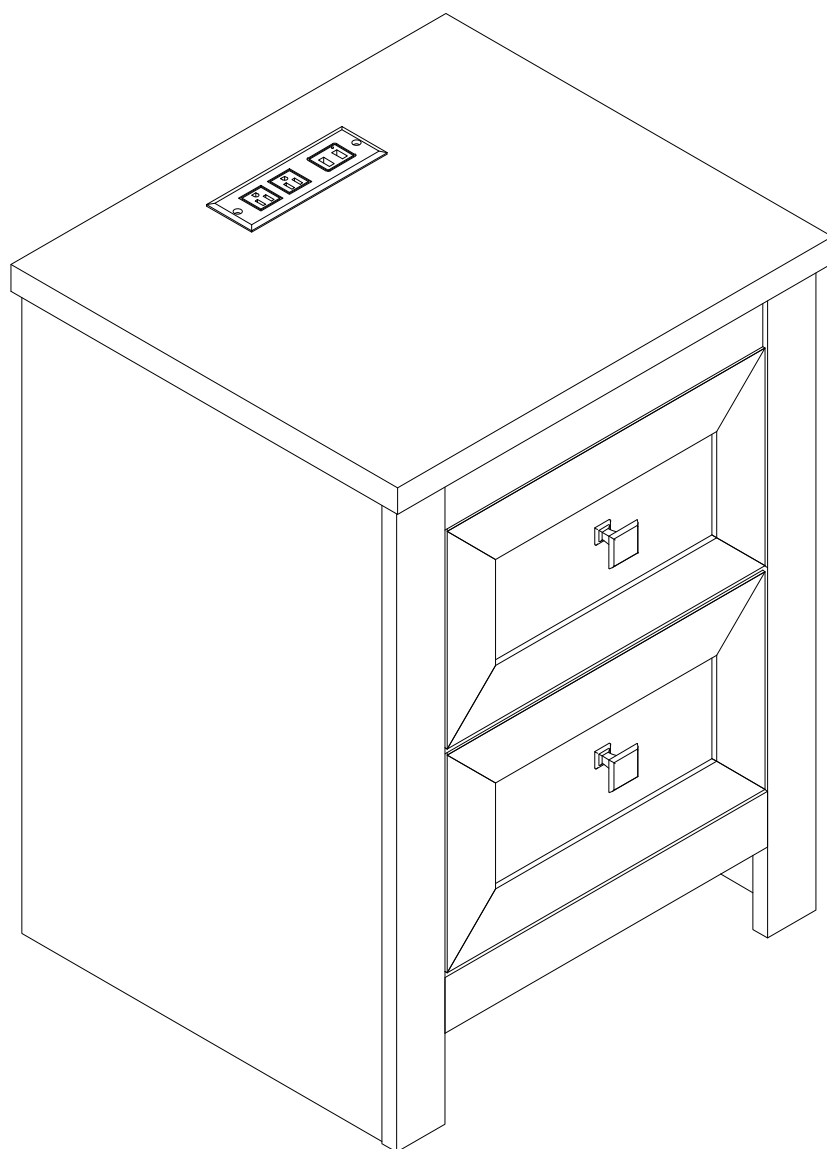

Assembly is complete.