

ASSEMBLY INSTRUCTIONS

STOOL

Thank you for purchasing this quality product. Be sure to check all packing material carefully for small parts that may have come loose inside the carton during shipment.

Hardware kit			
No	Description	Q'Ty	
A	Hex Nut 5/16"	4 pcs	
B	Lock Washer 5/16"	11 pc	
C	Flat Washer 5/16"	11 pc	
D	Long Bolt 1/4" x 3-1/3"	4 pc	
E	Short Bolt 1/4" x 1.5"	3 pc	
F	Allen Key	1 pc	
G	Key Wrench	1 pc	
H	Screw 1/6" x 1-1/2"	6 pcs	

Key Parts			
No	Code	Description	Q'Ty
1	A	Chair Back	1 pc
2	B	Complete Seat	1 pc
3	C	Right Facing Front Leg	1 pc
4	D	Left Facing Front Leg	1 pc
5	E	Right Facing Side Stretcher	1 pc
6	F	Left Facing Side Stretcher	1 pc
7	G	Front Stretcher	1 pc
8	H	Chair/ Bench Floor glide	4 pcs

STEP 1

- Carefully lay Chair Back flat on a smooth flat surface to prevent scratches.
- Affix Complete Seat to Chair Back by inserting a Flat Washer (C), Lock Washer (B) with Short Bolt (E) into each of the hole on the back rail of the seat, and Long Bolt (D) with washers into each of 2 holes in the Complete Seat corners. (See Detail A & B).
- Tighten screws with provided Allen Key (F) by turning clockwise until secure

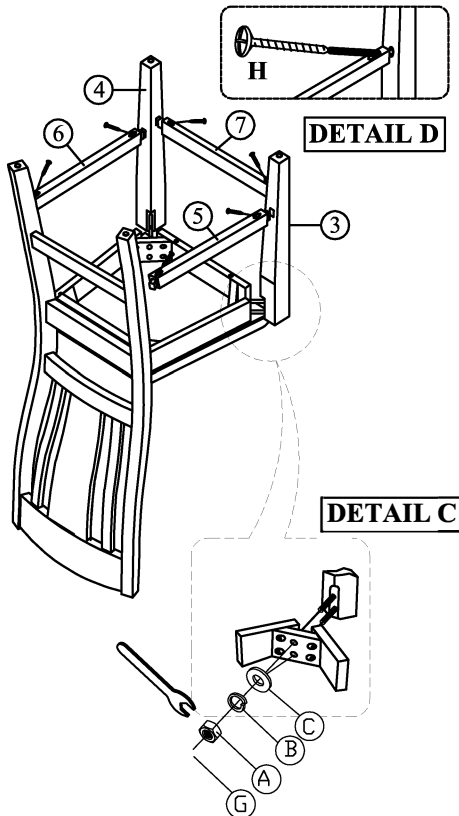
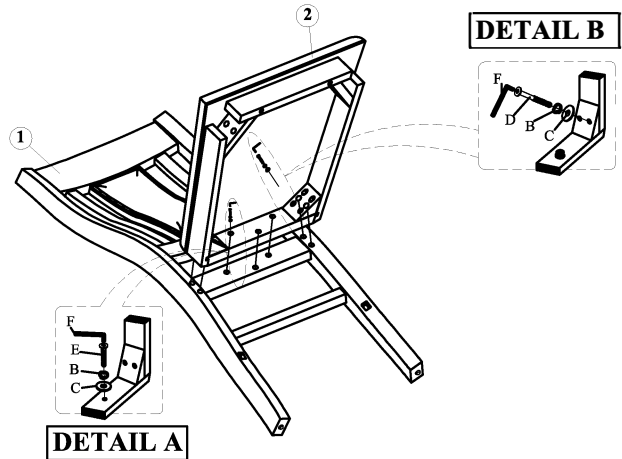

FABRIC CARE INSTRUCTION REGULAR CARE:
Clean with shampoo, foam, or dry cleaning solvents as desired. Do not saturate with liquid. Pile fabrics may require brushing to restore appearance. Cushion covers should not be removed and dry cleaned.

FABRIC CONTENT:
100% Polyester; Cleaning code "WS"

STEP 2

- Carefully turn chair upside down and attach each Front Leg to the front corners of the Complete Seat (Keeping in mind of the right side and left side leg) with a Flat Washer (C), Lock Washer (B) and Nut (A). (See detail C). Keep nut loose at this point. Insert right side stretcher and left side stretcher between the Front and Back Legs, then insert the Front Stretcher between the two Front Legs. (Make sure that the side stretchers are not at an angle as the front legs are on the wrong side). Fasten stretchers to legs with Screws (H) using a Screwdriver (not provide).
- Be sure to level the chair prior to tightening front leg nuts with wrench provided (G).

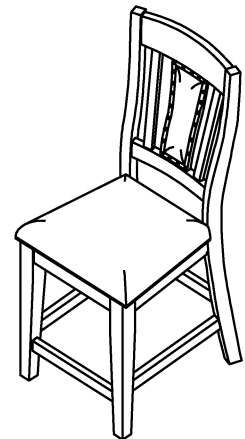

MADE IN VIETNAM