

Assembly Instructions

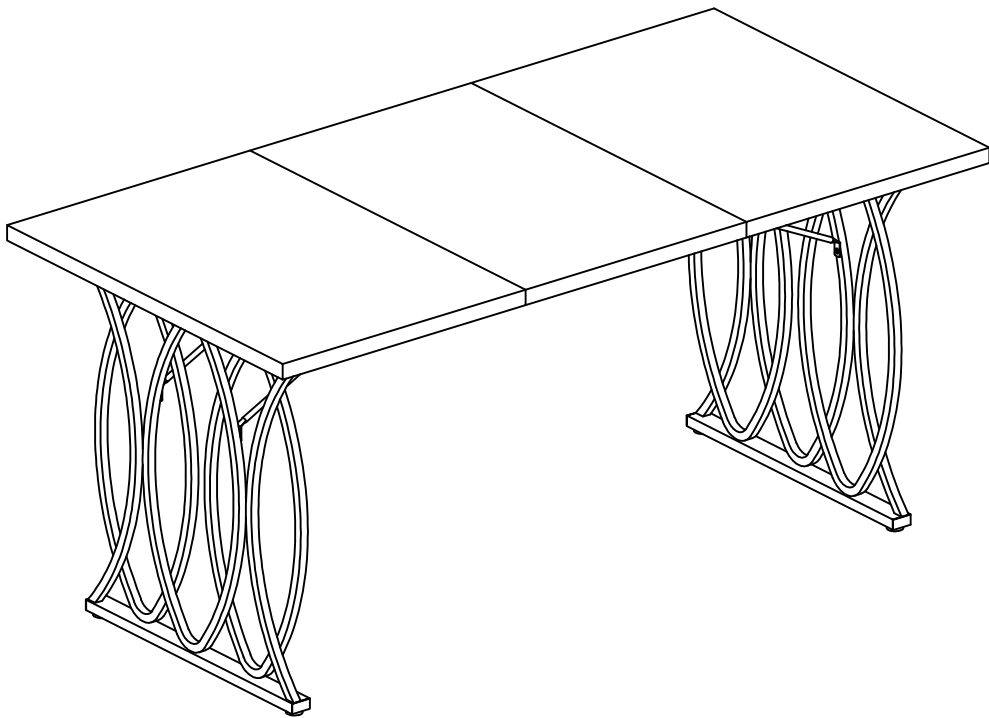

Conference Table/Dining Table

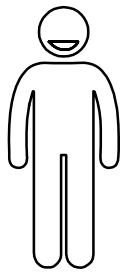

X2

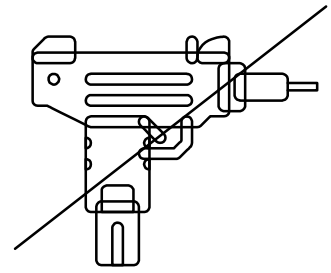
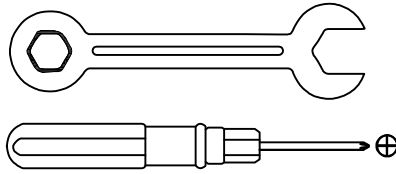

When using the electric screwdriver ,
Reduce the power and torque to avoid damaging the furniture

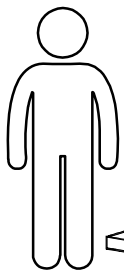

?

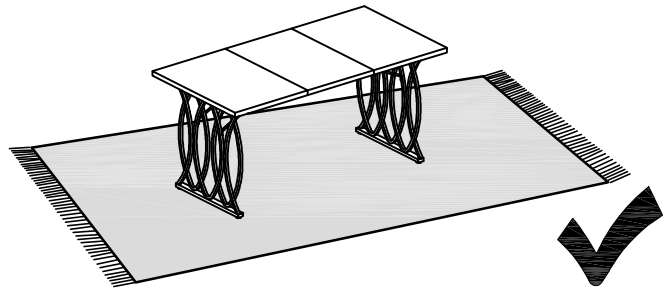
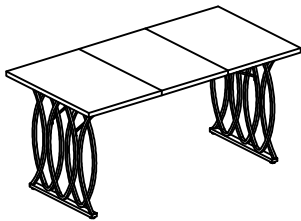
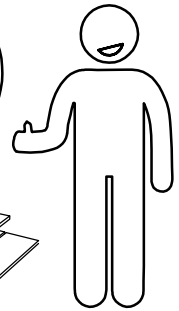
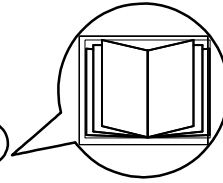
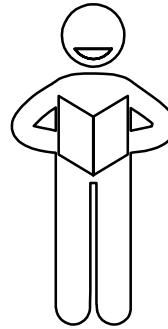
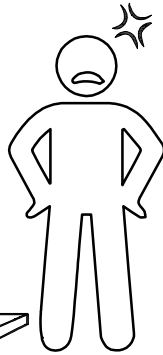

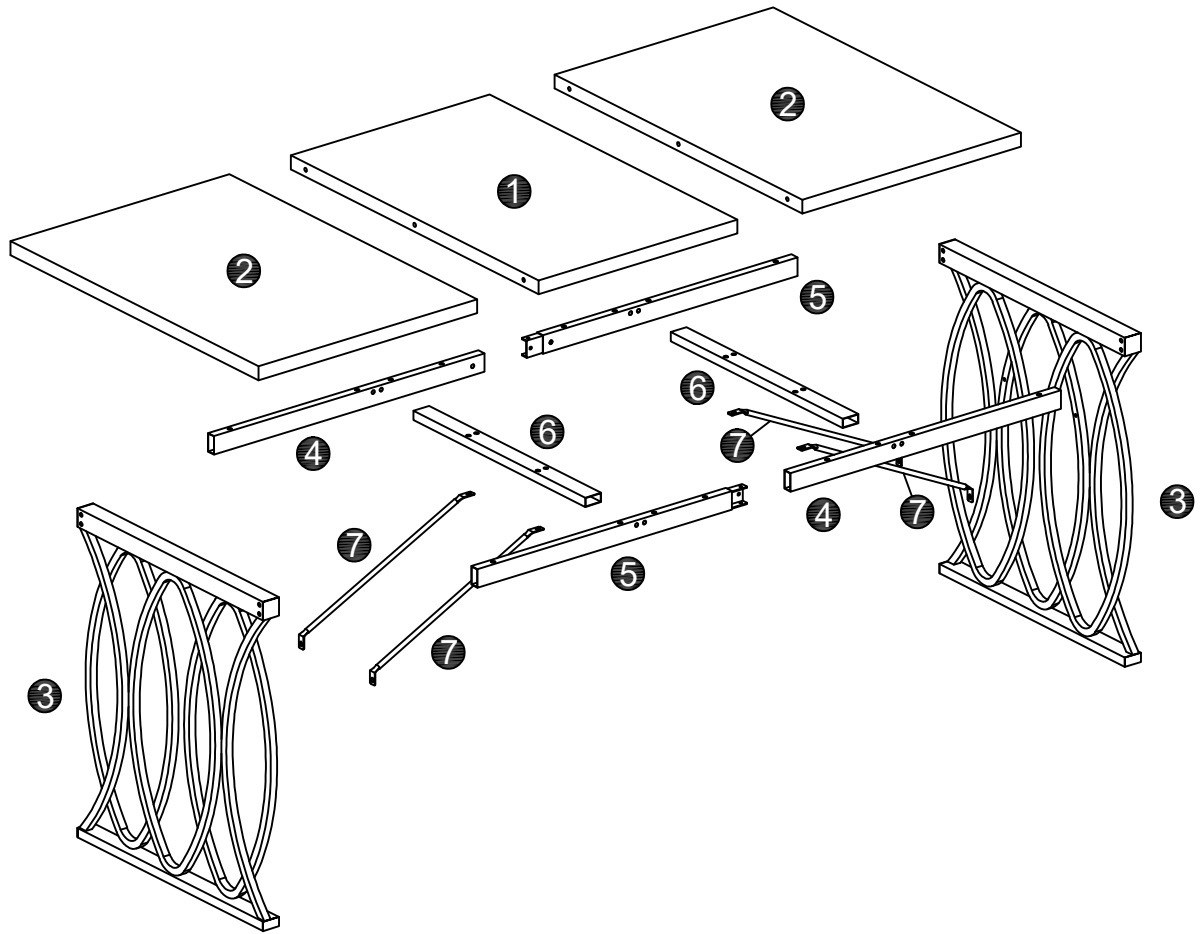

 Caution

Make sure all parts are included. Most board parts are labeled or stamped on the raw edge. contact us for free replacement if having damaged or missing parts.

Parts & Hardware List

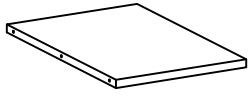

① 1pc

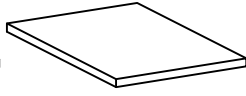

② 2pcs



③ 2pcs

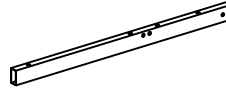

④ 2pcs

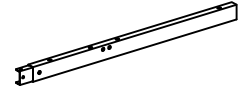

⑤ 2pcs

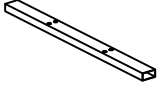

⑥ 2pcs



⑦ 4pcs

Hardware List



A
12pcs+1pc



B
8pcs+1pc



C
24pcs+1pc

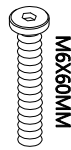

D
8pcs+1pc



E
6pcs+1pc



F
2pcs



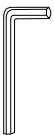

G
4pcs



H
1pc

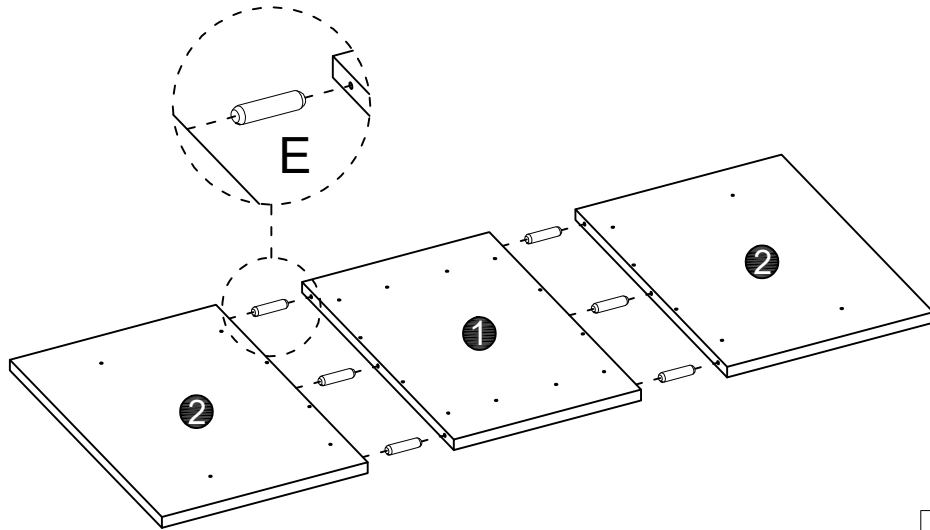

1



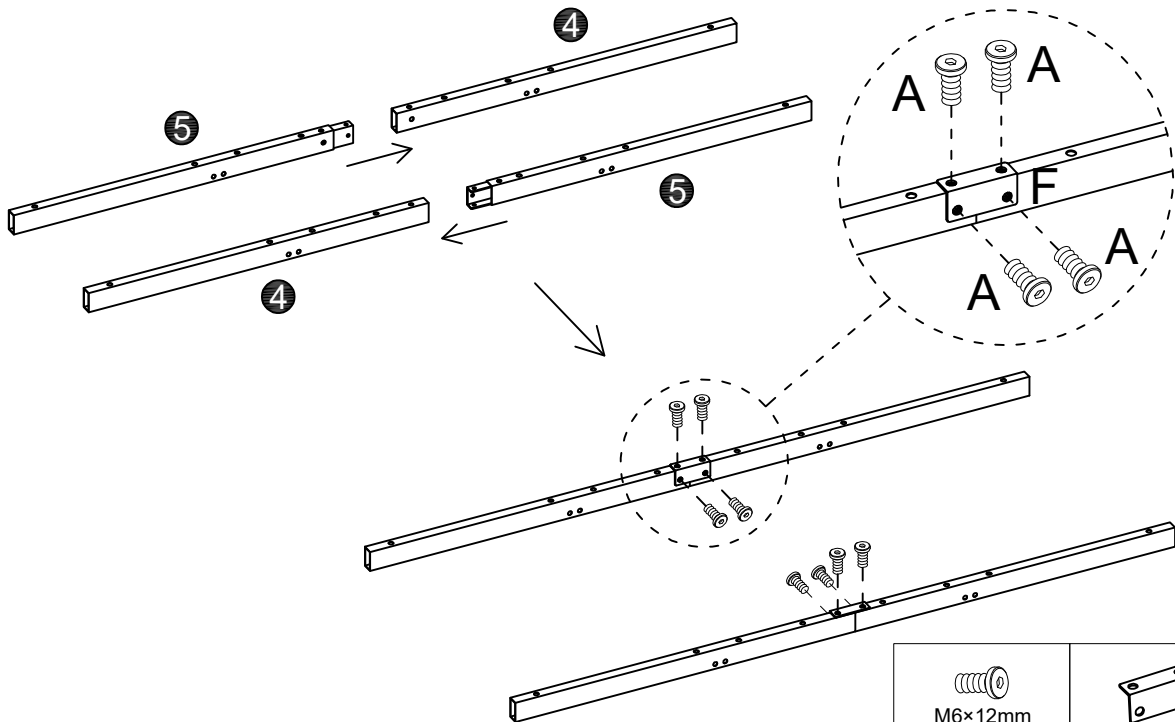

$\phi 8 \times 30 \text{mm}$
E × 6 pcs

2

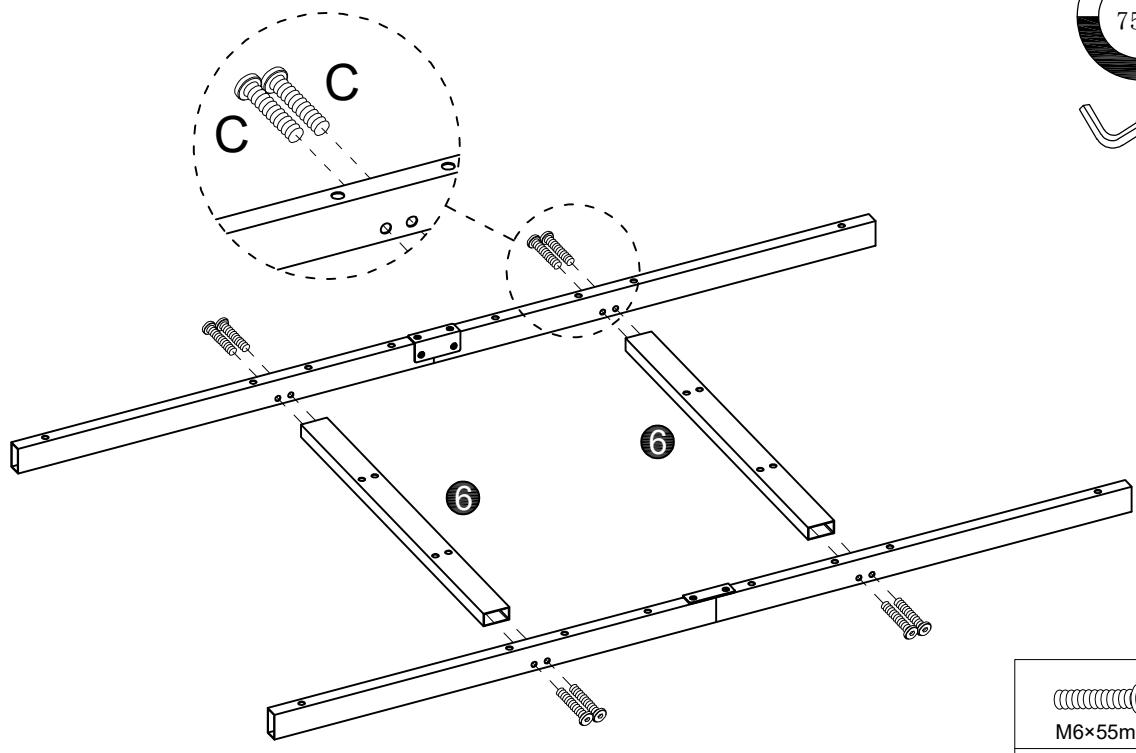

	
M6 × 12mm	
A × 8 pcs	F × 2 pcs

3

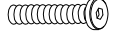

M6×55mm
C × 8pcs

4

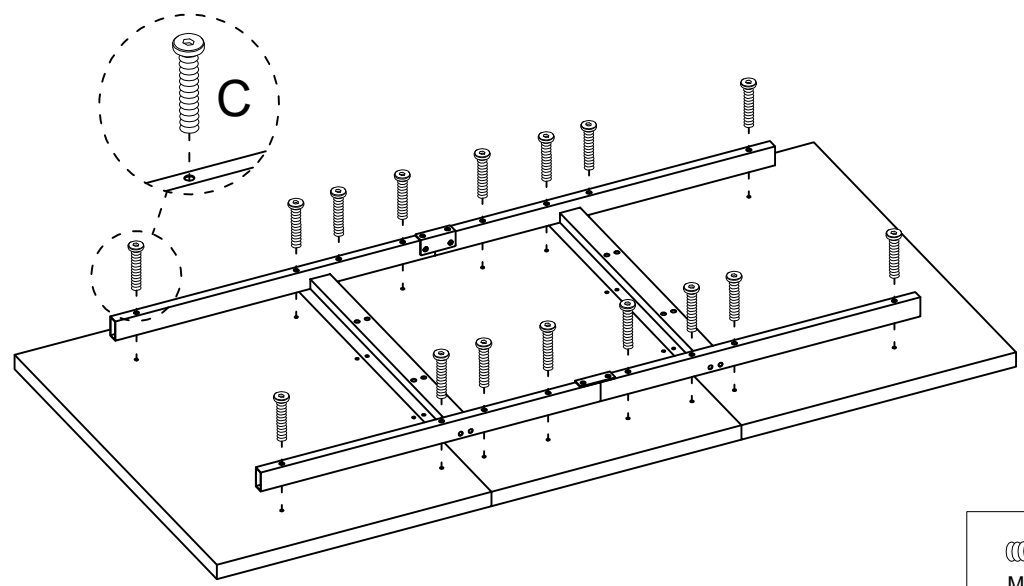

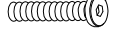

M6×55mm
C × 16pcs

5

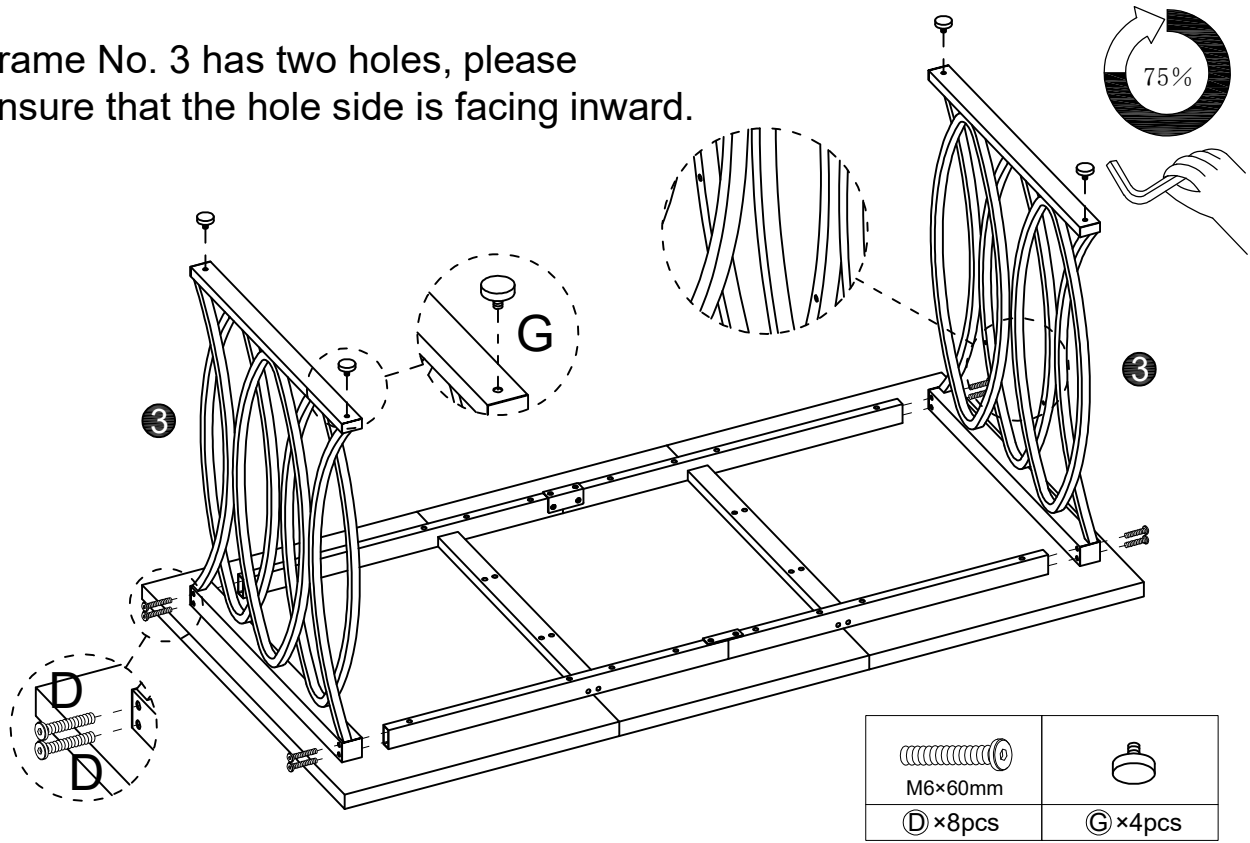
Frame No. 3 has two holes, please ensure that the hole side is facing inward.

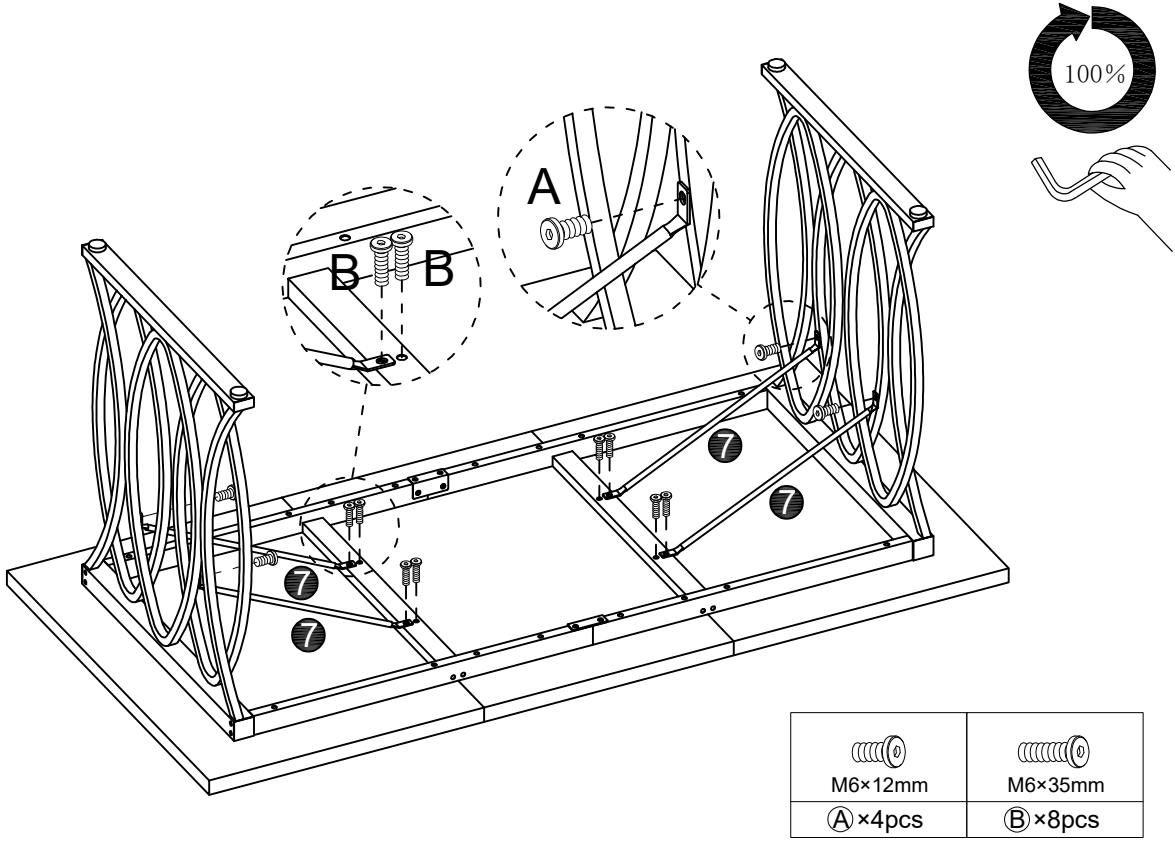

6



7

