

3Pcs Rope Lounge Chair Set

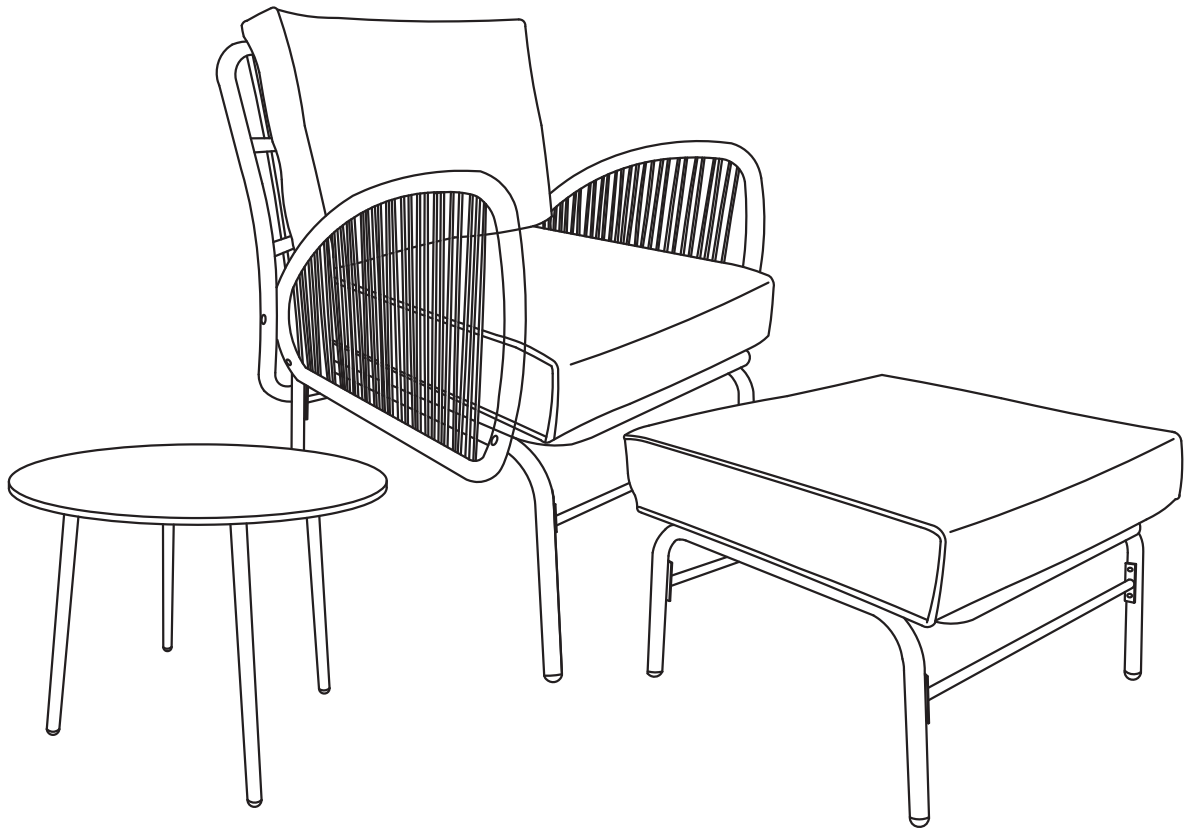

IMPORTANT
PLEASE READ BEFORE YOU COMMENCE ASSEMBLY

Follow the guidelines in this user guide to ensure correct assembly and care for this product.

3Pcs Rope Lounge Chair Set

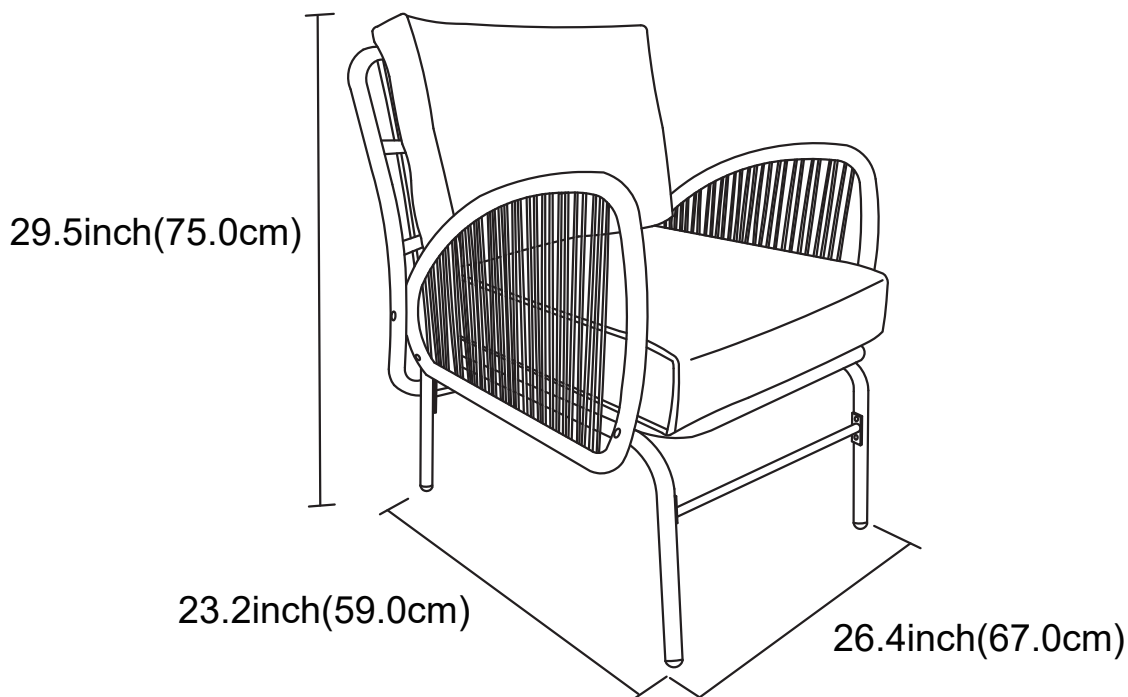
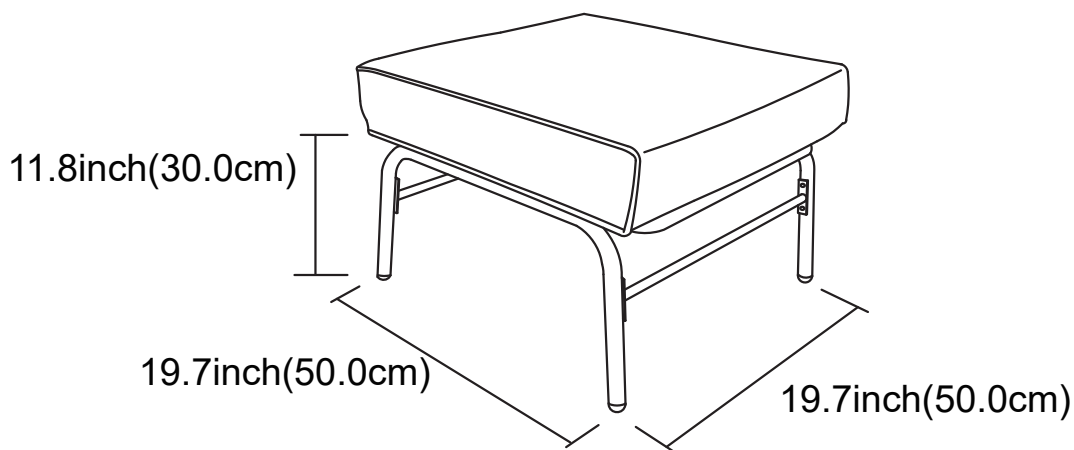
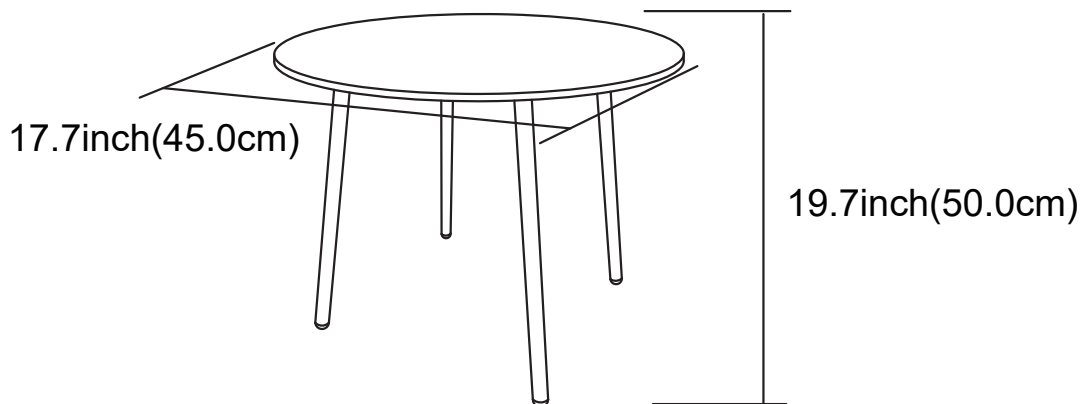

Catalog

Specifcations..... 01

Catalog..... 02

Notice..... 03

Part List And Screw Set List..... 04

How to Assemble The Side Table..... 05

How to Assemble The Footrest..... 06

How to Assemble The Chair..... 08









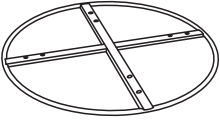
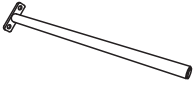
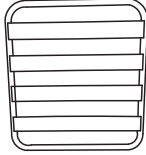

Before You Begin

Instructions are supplied in this manual and contain all appropriate information for your product.

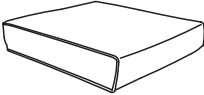
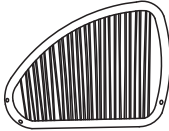
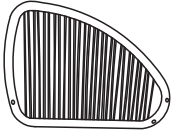

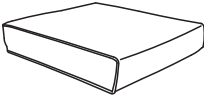
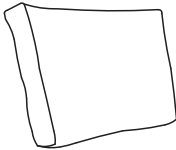

Review all instructions before you begin and during assembly, follow the step sequence carefully for correct results.

1. All parts are packaged within the carton. Separate contents of the carton by the part number while reviewing parts list. Check to be sure that you have all the necessary parts for building.
2. Familiarize yourself with the hardware and fasteners for easier use during construction.
3. The first few steps show how to join related parts which is to obtain larger sub-assemblies be used later.
4. Note that extra fasteners have been supplied for your convenience.
5. If you have an electric screwdriver, you can use it instead of the screwdriver we provide. An electric screwdriver can help you reduce assembly time.

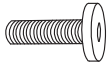

PART LIST

Part List			
L001 	L002 	L003 	L004 
1PC	4PCS	1PC	2PCS
L005 	L006 	L007 	L008 
2PCS	1PC	1PC	1PC
L009 	L010 	L011 	L012 
1PC	1PC	1PC	1PC
L013 	L014 	L015 	
2PCS	1PC	1PC	

Screw Set

A 	B 	C 	D 	E 
M6*12	M6*15	M6*35	M6	4*4
8PCS	16PCS	16PCS	40PCS	1PC

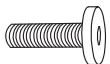
Extra (Screw Set)

A 	B 	C 	D 	
M6*12	M6*15	M6*35	M6	
1PC	2PCS	2PCS	5PCS	

How To Assemble The Side Table

STEP 01: Turn the Tabletop (L001) over so that the underside faces upwards, then secure the Table Legs (L002) to the tabletop using screws.

NOTE: When attaching each leg, tighten both screws simultaneously. Finally, ensure all screws are fully tightened.

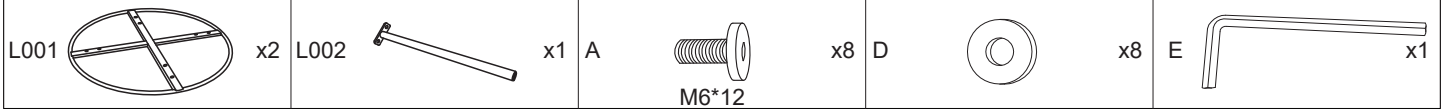
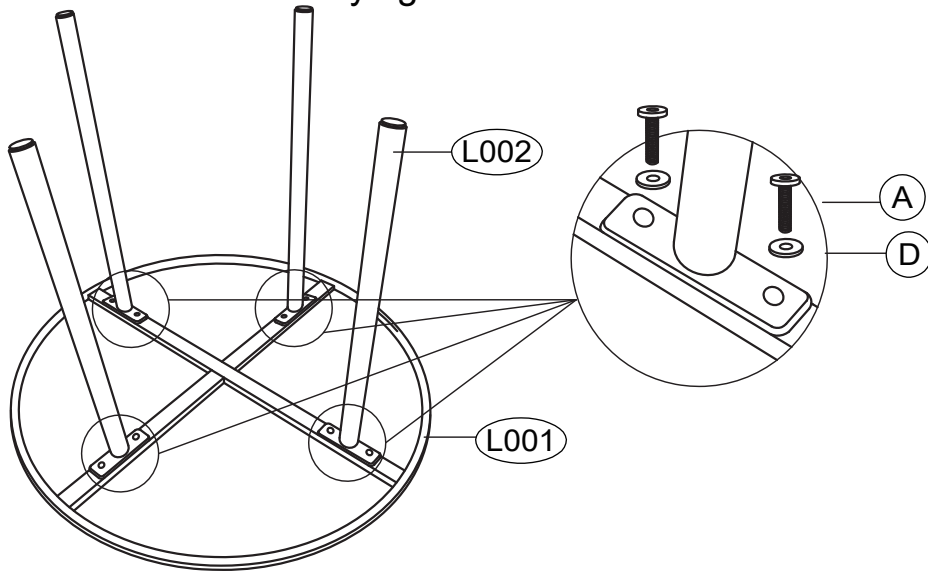

STEP 02: Flip the tabletop back into position and rotate the adjustable feet to stabilise the table.

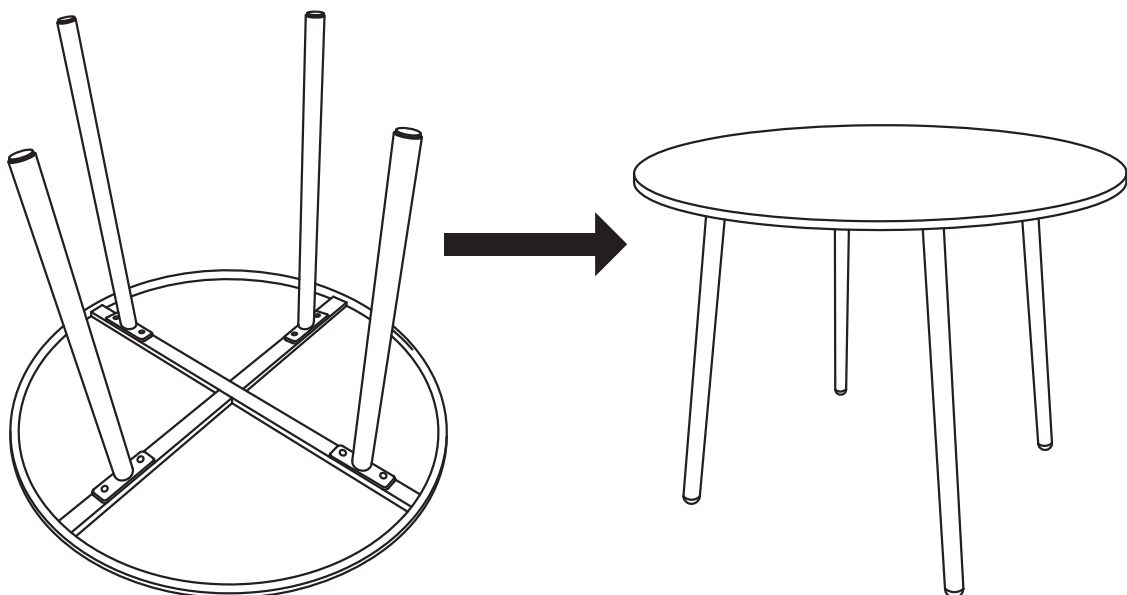

How To Assemble The Footrest

STEP 01: Turn the Footrest Frame(L003) over so that the reverse side faces upwards. Secure the Footrest Leg (L004) to left and right side of the Footrest Leg(L003) using screws.

NOTE: Do not fully tighten the screws.

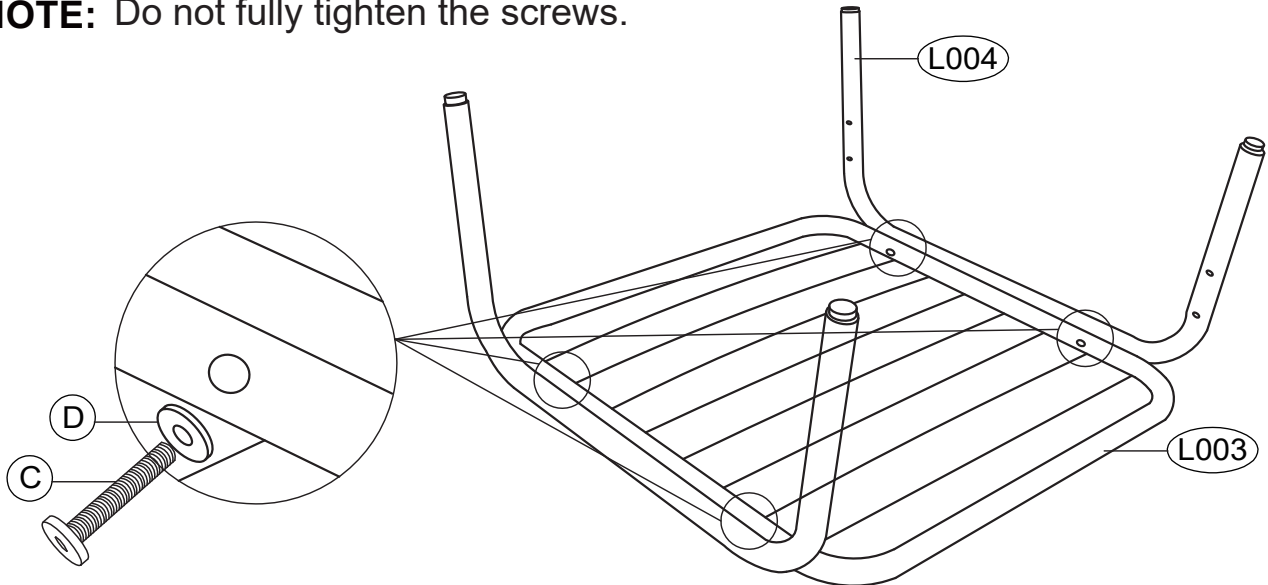

L003		x1	L004		x2	C		x4	D		x4	E		x1
							M6*35							

STEP 02: Secure the two Footrest Support Rod (L005) to the centre of the newly installed two legs respectively, fastening them to the front and rear sides of each leg.

NOTE: Ensure all screws are fully tightened.

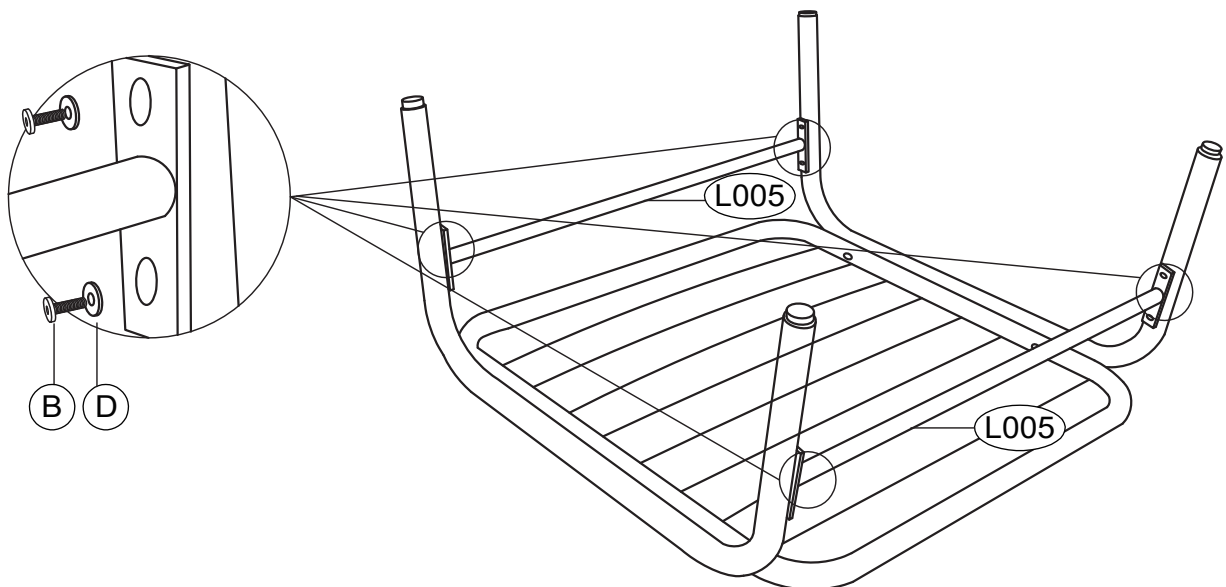

L005		x2	B		x8	D		x8	E		x1
				M6*15							

Installation steps

STEP 03: Flip the Footrest back into position. Place the Footrest Cushion (L006) atop the newly installed footrest, securing it to the metal frame using the Velcro fasteners on the underside of the cushion.

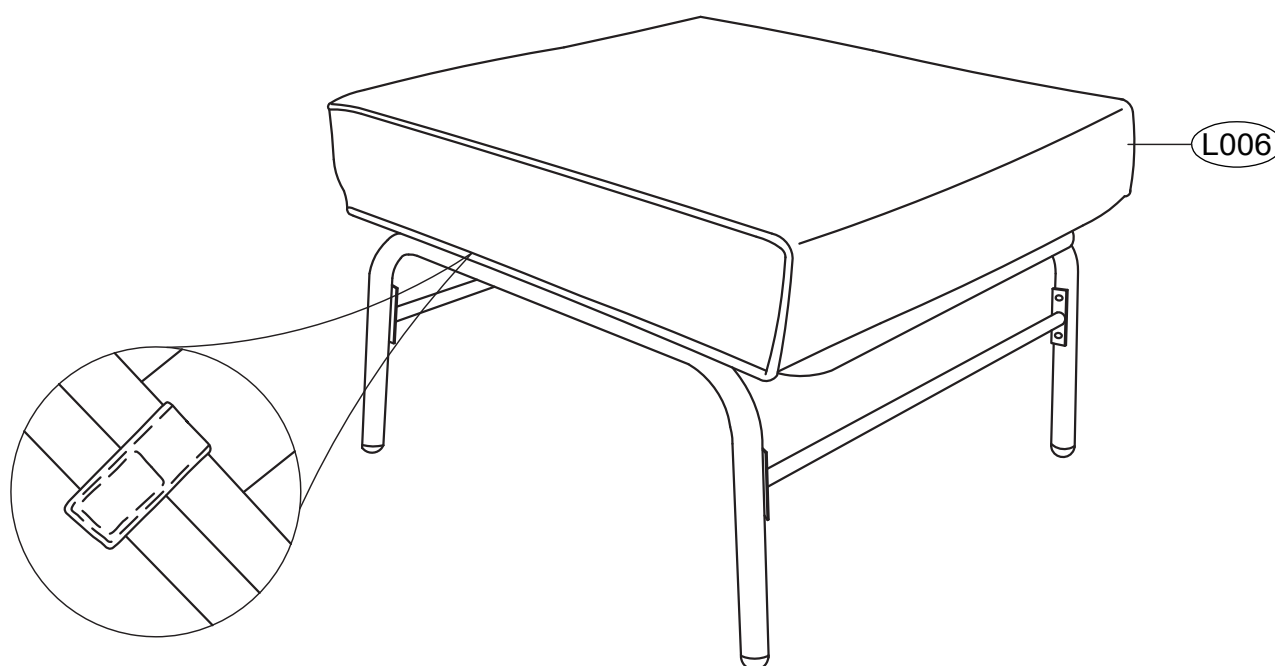

L006

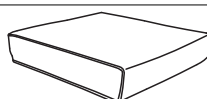

x1

Installation steps





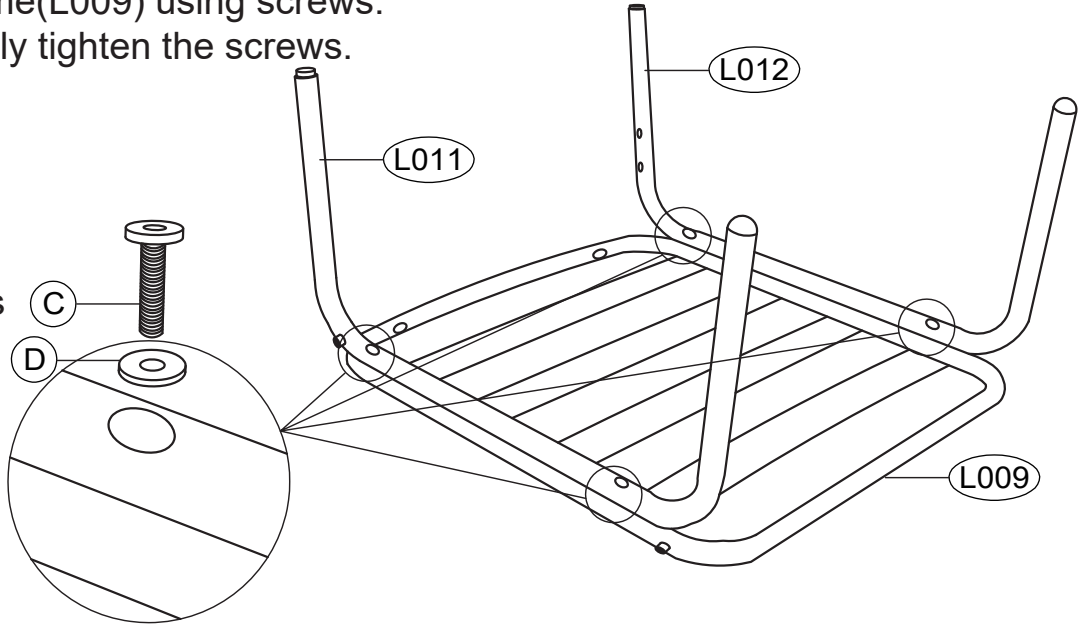

How To Assemble The Chair

STEP 01: Turn the Seat Frame (L009) over so that the reverse side faces upwards. Secure the Left Leg (L011) and the Right leg (L012) to either side of the Seat Frame (L009) using screws.

NOTE: Do not fully tighten the screws.

The chair legs equipped with adjustable foot pads are the rear legs, which should be positioned closer to the side of the seat frame featuring the holes.





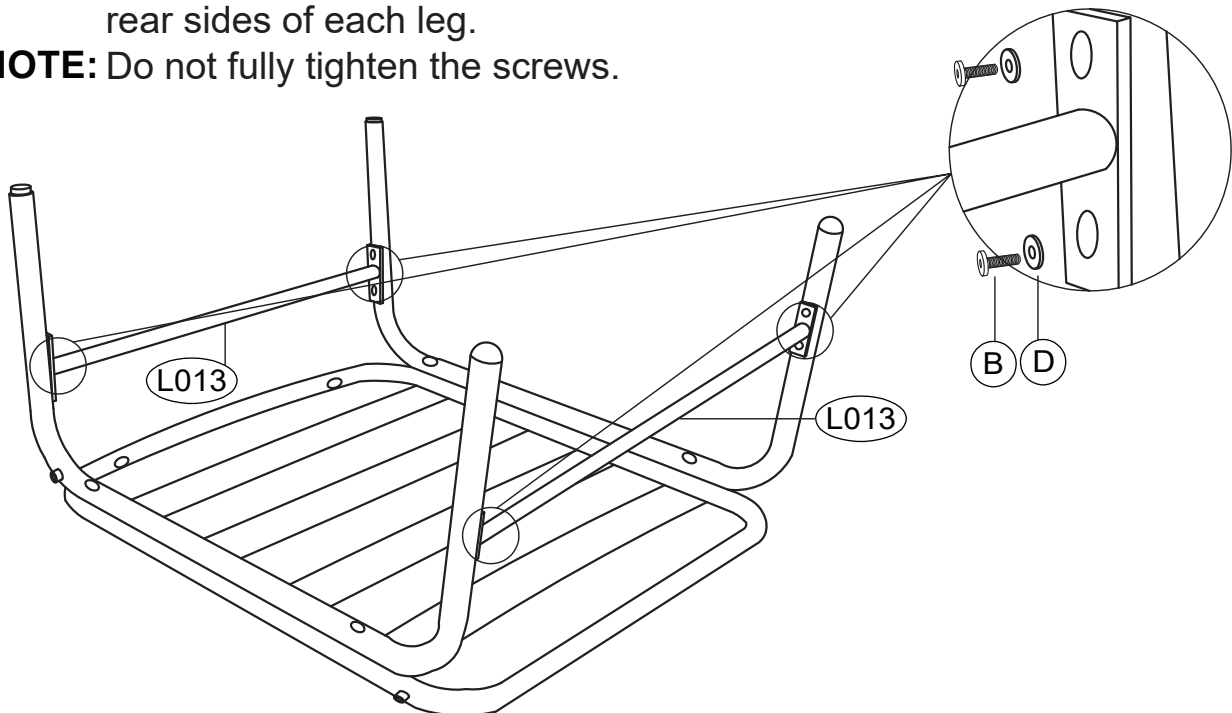

L009		x1	L011		x1	L012		x1	C		x4	D		x4	E		x1
										M6*35							

STEP 02: Secure the two Seat Support Rod (L013) to the centre of the newly installed left and right legs respectively, fastening them to the front and rear sides of each leg.

NOTE: Do not fully tighten the screws.







L013		x1	B		x8	D		x8	E		x1
				M6*15							

Installation steps

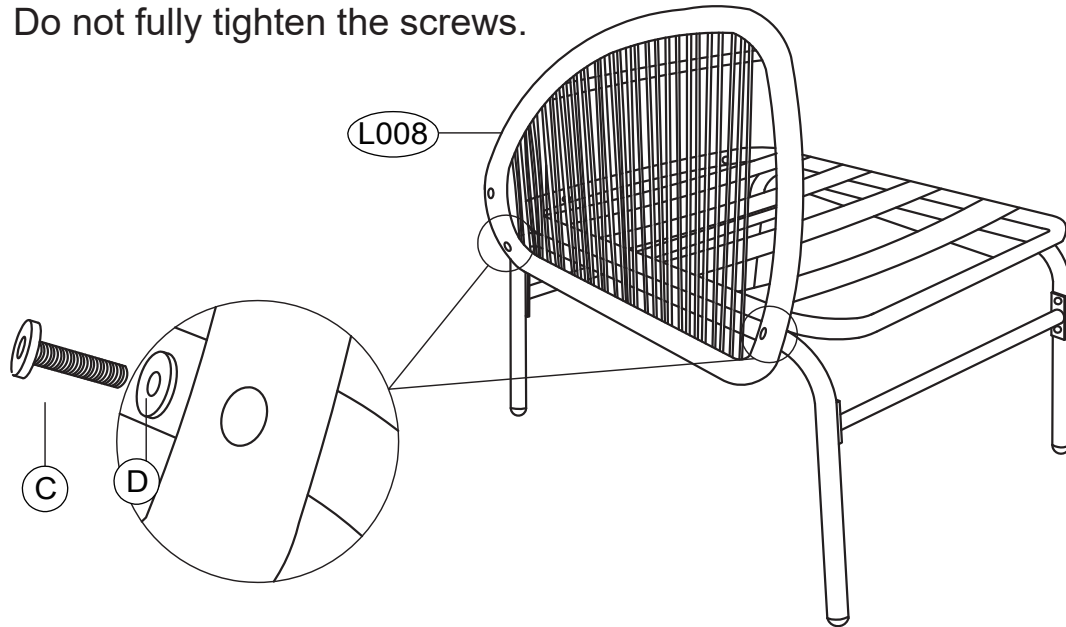
STEP 03: Flip the Seat back into position. Align the front and rear screw holes on the lower section of the Right Armrest(L008) with the corresponding front and rear screw holes on the outer side of the Right Leg(L012) of the newly installed seat, then secure them with screws.

NOTE: Do not fully tighten the screws.

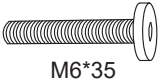



L008		x1	C		x2	D		x2	E		x1
				M6*35							

STEP 04: In the same manner as the previous step, secure the Left Armrest(L007) to the Left Leg (L011) of the chair using screws.

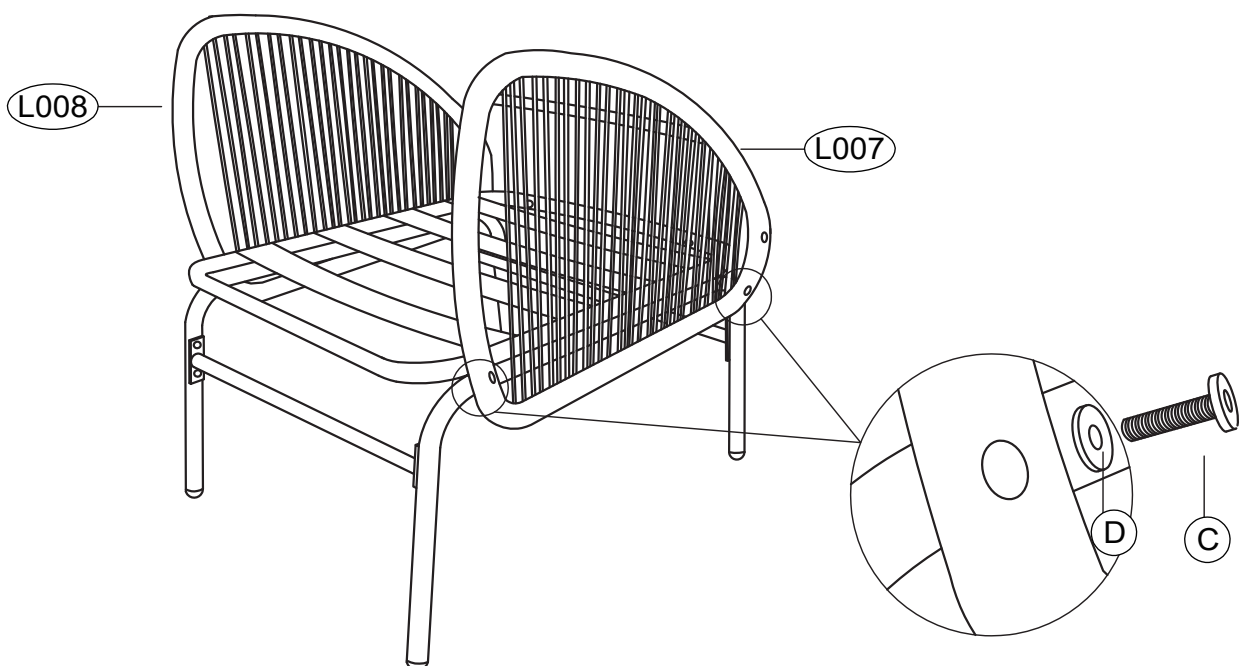
NOTE: Do not fully tighten the screws.

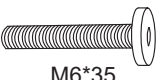





L008		x1	C		x2	D		x2	E		x1
				M6*35							

Installation steps

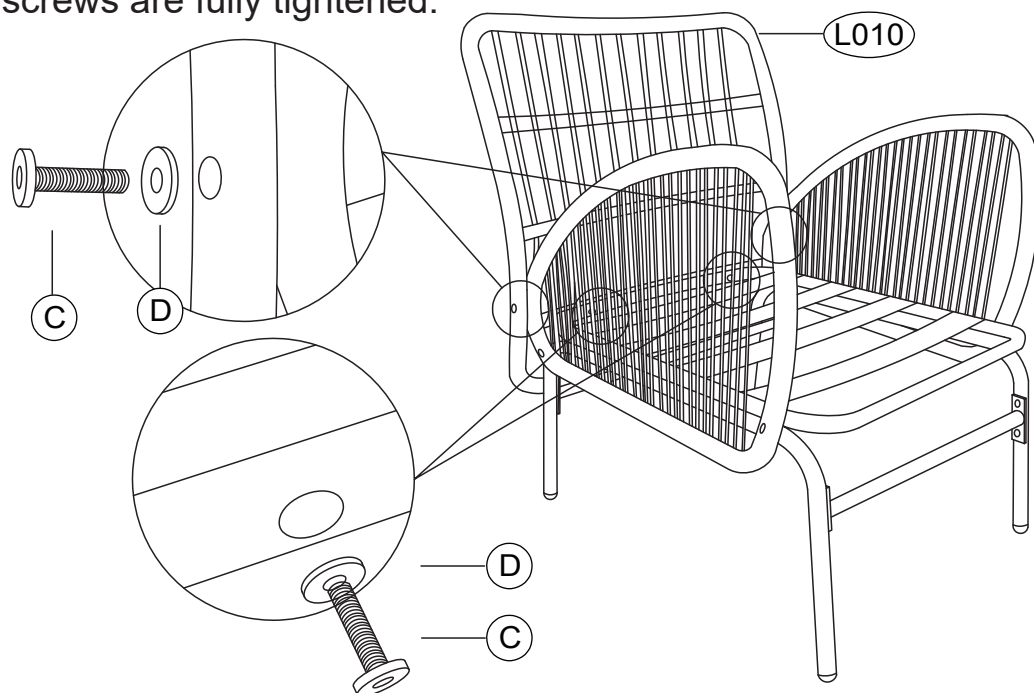
STEP 05: Secure the Seat Backrest(L010) to the left and right armrests and the rear section of the Seat Frame using screws.



NOTE: Ensure all screws are fully tightened.

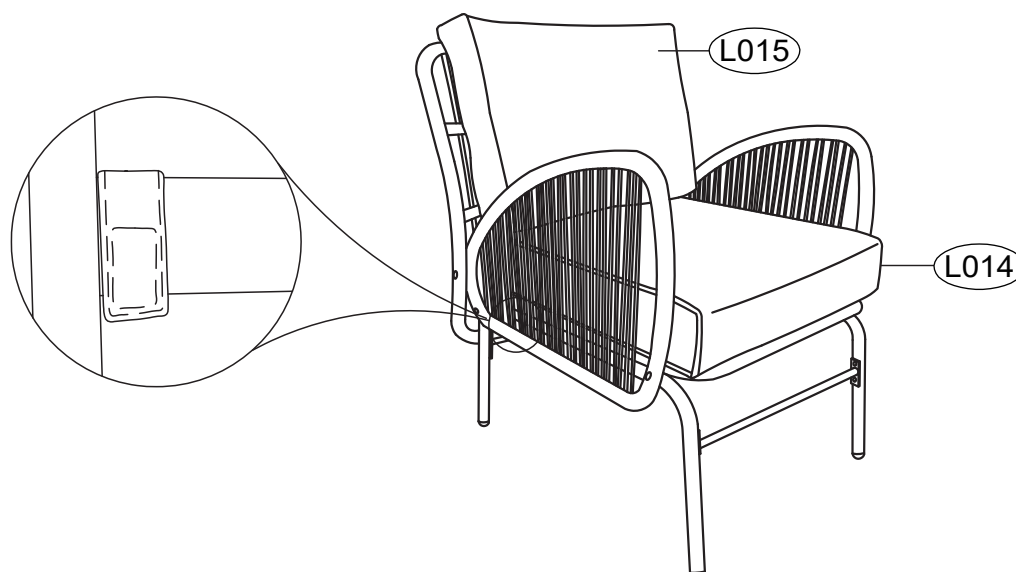

L010		x1	C		x4	D		x4	E		x1
				M6*35							

STEP 06: Place the Seat Cushion(L014) and Back Cushion(L015) on the newly assembled chair. Securing the Seat Cushion (L014) to the metal frame using the Velcro fasteners on the underside of the cushion.



L014		x2	L015		x2
------	---	----	------	---	----

3-teiliges Seil-Liegestuhl-Set

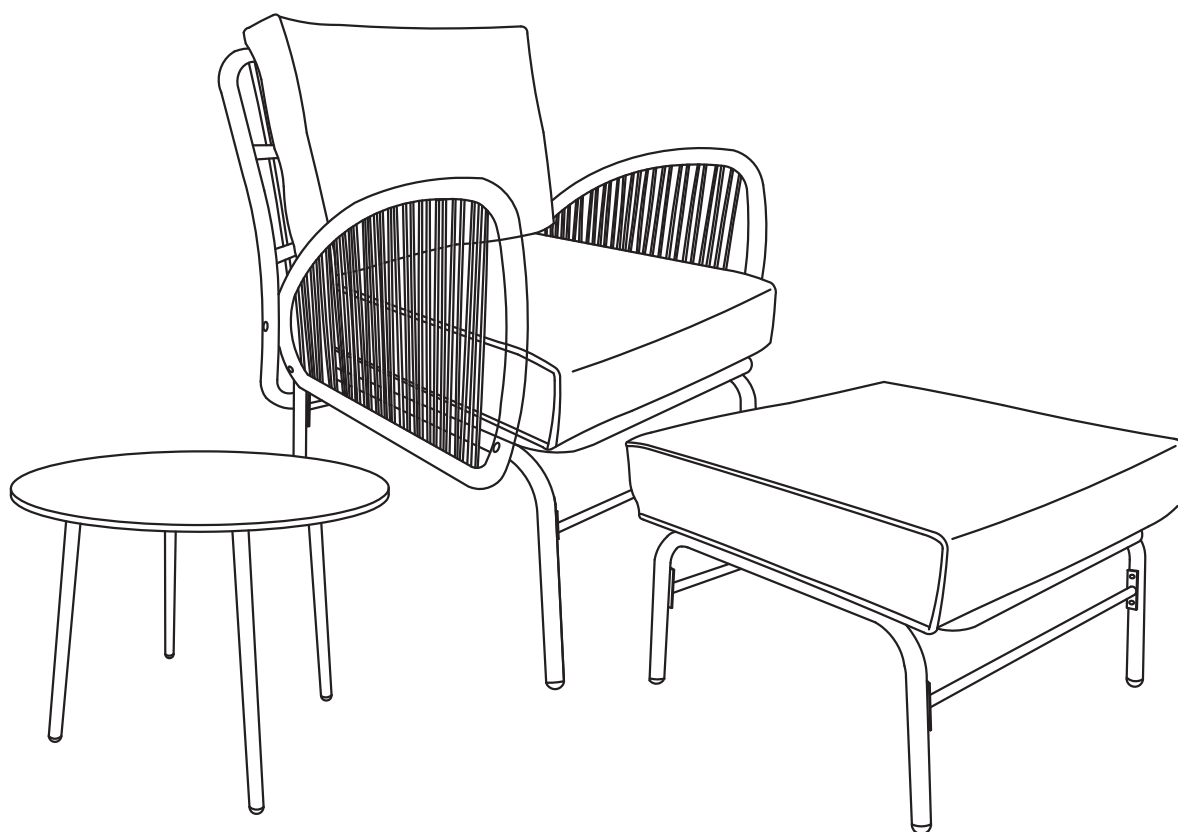

WICHTIG

BITTE VOR BEGINN DER MONTAGE LESEN

Befolgen Sie die Anweisungen in dieser Bedienungsanleitung, um eine korrekte Montage und Pflege dieses Produkts sicherzustellen.

3-teiliges Seil-Liegestuhl-Set

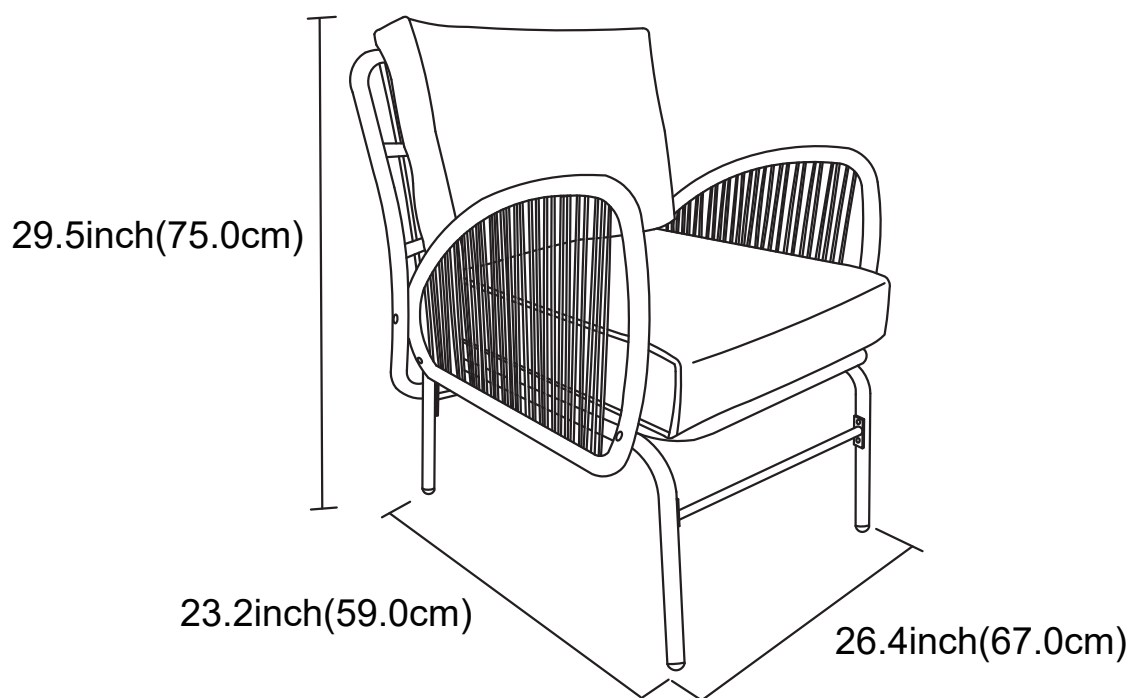
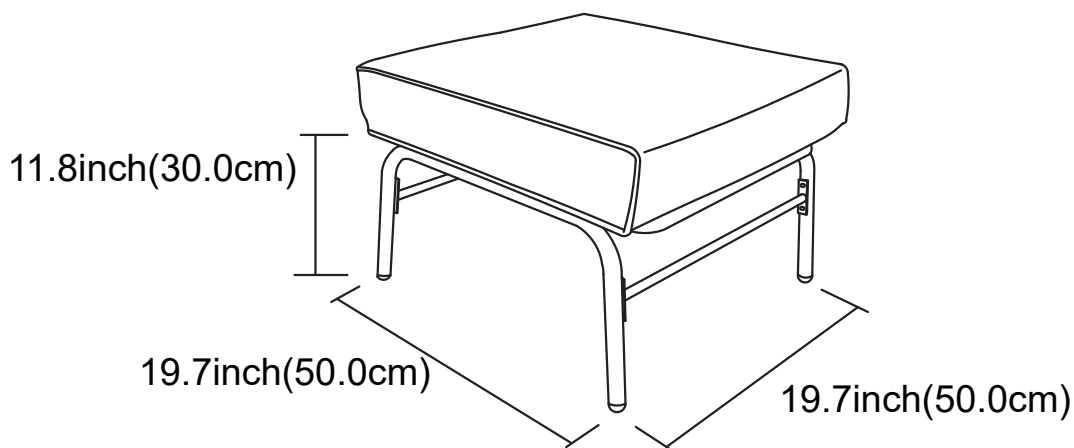

Katalog

Spezifikationen.....	01
Katalog.....	02
Hinweis.....	03
Teileliste und Schraubensatzliste.....	04
So bauen Sie den Beistelltisch zusammen.....	05
So bauen Sie die Fußstütze zusammen.....	06
So bauen Sie den Stuhl zusammen.....	08











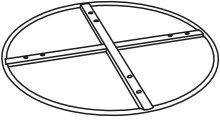
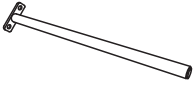
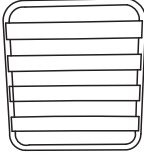

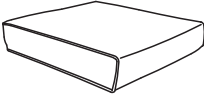
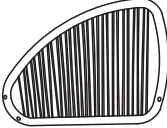
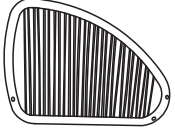

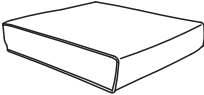
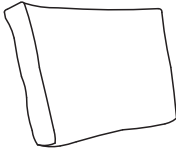

Bevor Sie beginnen

Die Anweisungen in diesem Handbuch enthalten alle relevanten Informationen zu Ihrem Produkt.

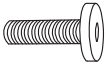
Lesen Sie alle Anweisungen vor Beginn und während der Montage sorgfältig durch und befolgen Sie die einzelnen Schritte genau, um ein korrektes Ergebnis zu erzielen.

1. Alle Teile sind im Karton verpackt. Sortieren Sie den Inhalt des Kartons anhand der Teilenummern, während Sie die Teileliste durchgehen. Vergewissern Sie sich, dass Sie alle für den Zusammenbau erforderlichen Teile haben.
2. Machen Sie sich mit den Beschlägen und Befestigungselementen vertraut, um den Zusammenbau zu erleichtern.
3. Die ersten Schritte zeigen, wie Sie verwandte Teile miteinander verbinden, um größere Baugruppen zu erhalten, die später verwendet werden.
4. Beachten Sie, dass Ihnen zusätzliche Befestigungselemente zur Verfügung gestellt wurden.
5. Wenn Sie einen Elektroschrauber besitzen, können Sie diesen anstelle des mitgelieferten Schraubendrehers verwenden. Mit einem Elektroschrauber können Sie die Montagezeit verkürzen.

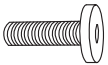
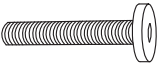
TEILELISTE

Teileliste				
L001 	L002 	L003 	L004 	
1PC	4PCS	1PC	2PCS	
L005 	L006 	L007 	L008 	
2PCS	1PC	1PC	1PC	
L009 	L010 	L011 	L012 	
1PC	1PC	1PC	1PC	
L013 	L014 	L015 		
2PCS	1PC	1PC		
Schraubensatz				
A 	B 	C 	D 	E 
M6*12	M6*15	M6*35	M6	4*4
8PCS	16PCS	16PCS	40PCS	1PC
Extra (Schraubensatz)				
A 	B 	C 	D 	
M6*12	M6*15	M6*35	M6	
1PC	2PCS	2PCS	5PCS	

So bauen Sie den Beistelltisch zusammen

SCHRITT 01: Drehen Sie die Tischplatte (L001) um, sodass die Unterseite nach oben zeigt, und befestigen Sie dann die Tischbeine (L002) mit Schrauben an der Tischplatte.

HINWEIS: Ziehen Sie beim Anbringen jedes Beins beide Schrauben gleichzeitig fest. Vergewissern Sie sich abschließend, dass alle Schrauben vollständig angezogen sind.

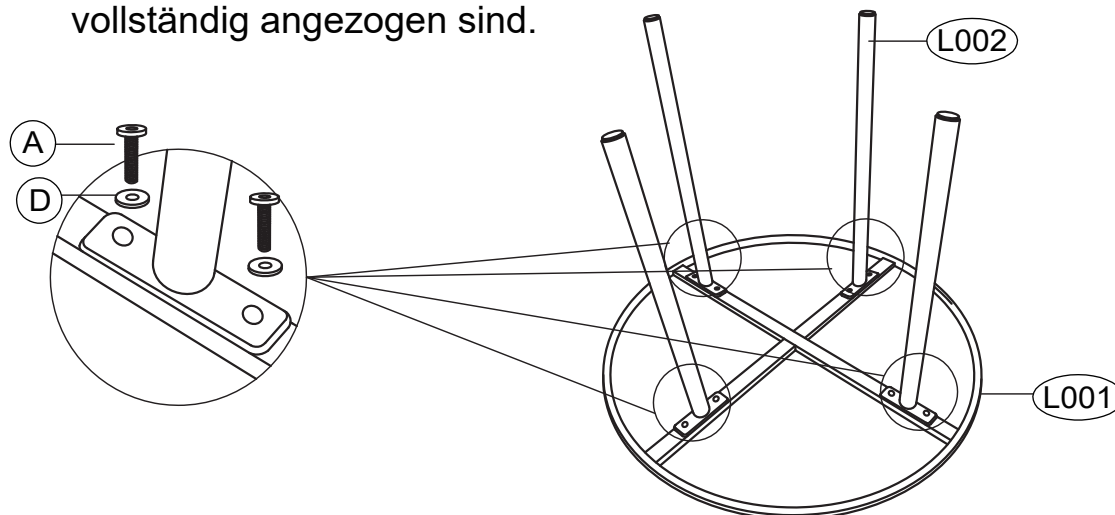

L001		x2	L002		x1	A		x8	D		x8	E		x1
							M6*12							

SCHRITT 02: Klappen Sie die Tischplatte wieder in ihre Position zurück und drehen Sie die verstellbaren Füße, um den Tisch zu stabilisieren.

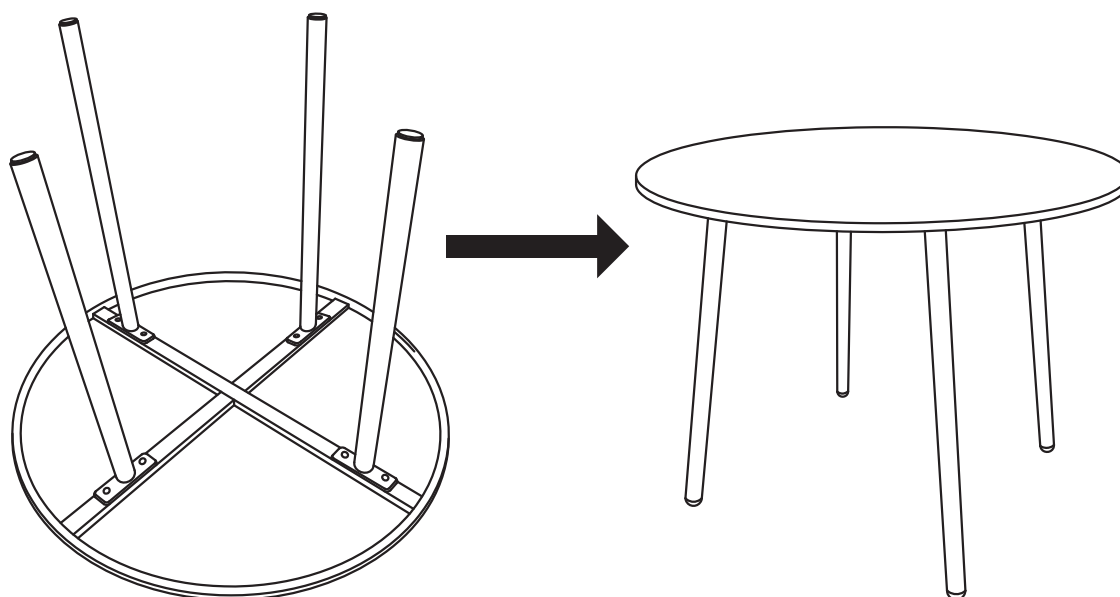



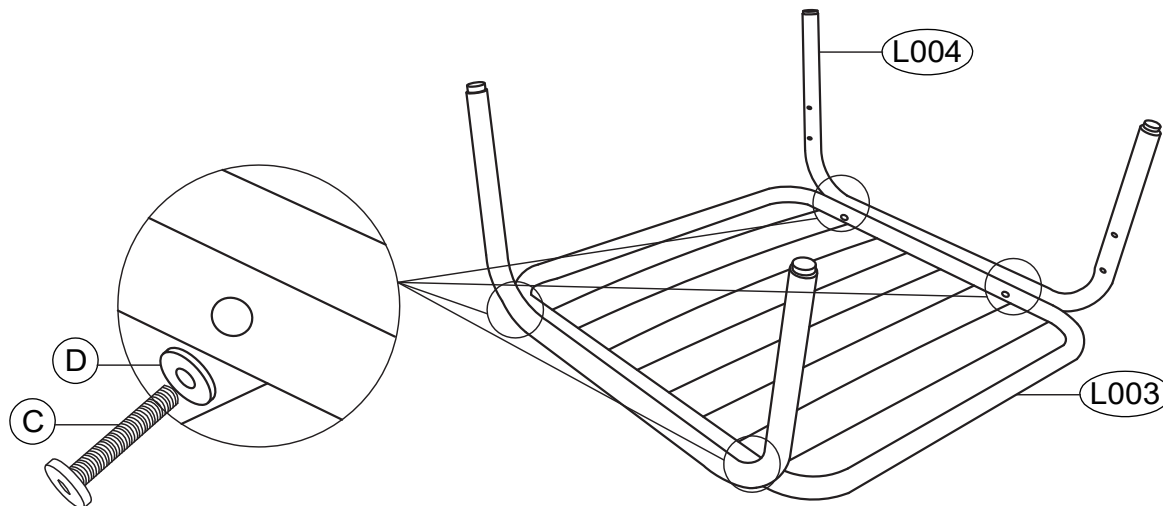

So montieren Sie die Fußstütze

SCHRITT 01: Drehen Sie den Fußstützenrahmen (L003) um, sodass die Rückseite nach oben zeigt. Befestigen Sie das Fußstützenbein (L004) mit Schrauben an der linken und rechten Seite des Fußstützenrahmens (L003).

HINWEIS: Ziehen Sie die Schrauben nicht vollständig fest.





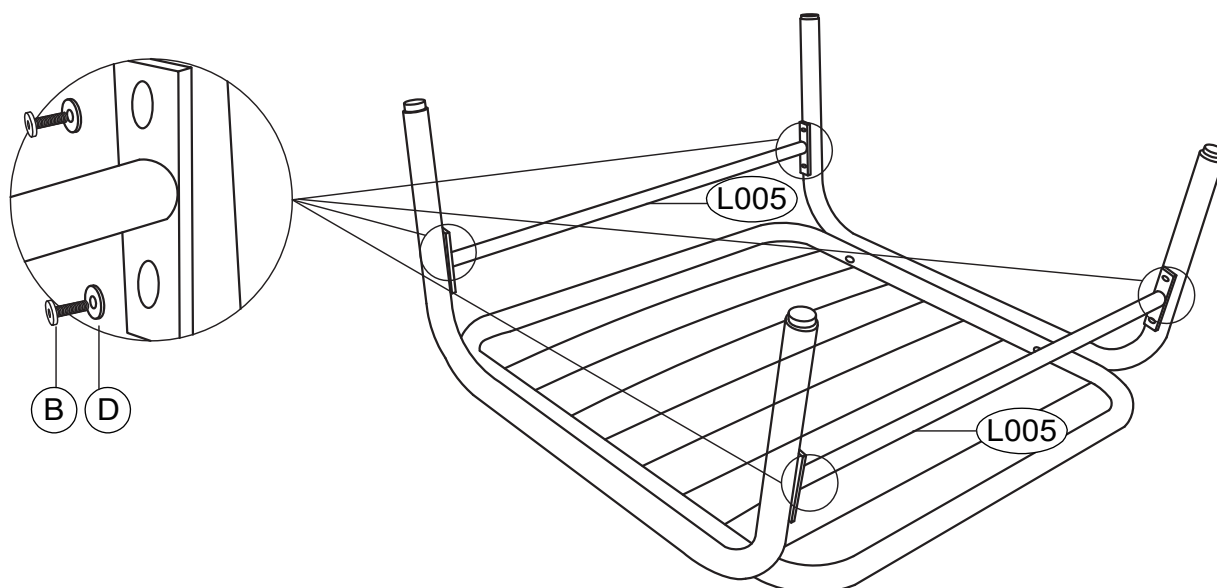

L003		x1	L004		x2	C		x4	D		x4	E		x1
M6*35														

SCHRITT 02: Befestigen Sie die beiden Fußstützen-Stützstangen (L005) jeweils in der Mitte der beiden neu installierten Beine und befestigen Sie sie an der Vorder- und Rückseite jedes Beins.

HINWEIS: Stellen Sie sicher, dass alle Schrauben vollständig angezogen sind.



L005		x2	B		x8	D		x8	E		x1
M6*15											

SCHRITT 03: Klappen Sie die Fußstütze wieder in ihre Position zurück. Legen Sie das Fußstützenkissen (L006) auf die neu installierte Fußstütze und befestigen Sie es mit den Klettverschlüssen an der Unterseite des Kissens am Metallrahmen.

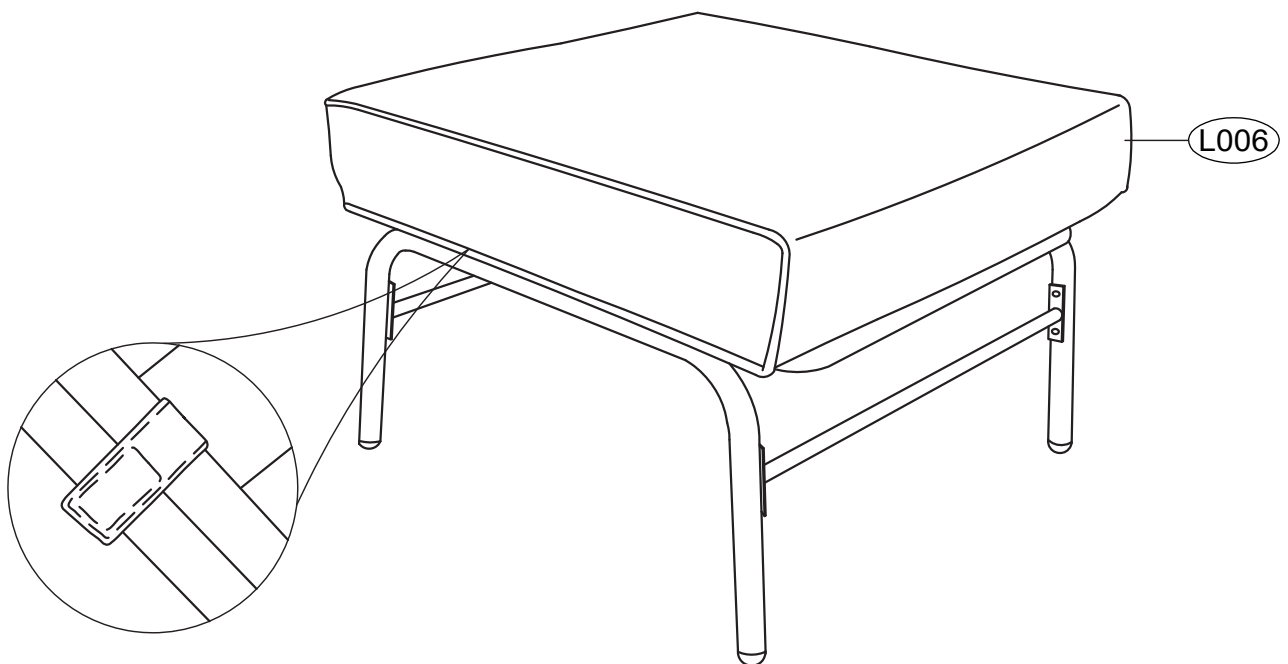

L006

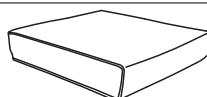

x1





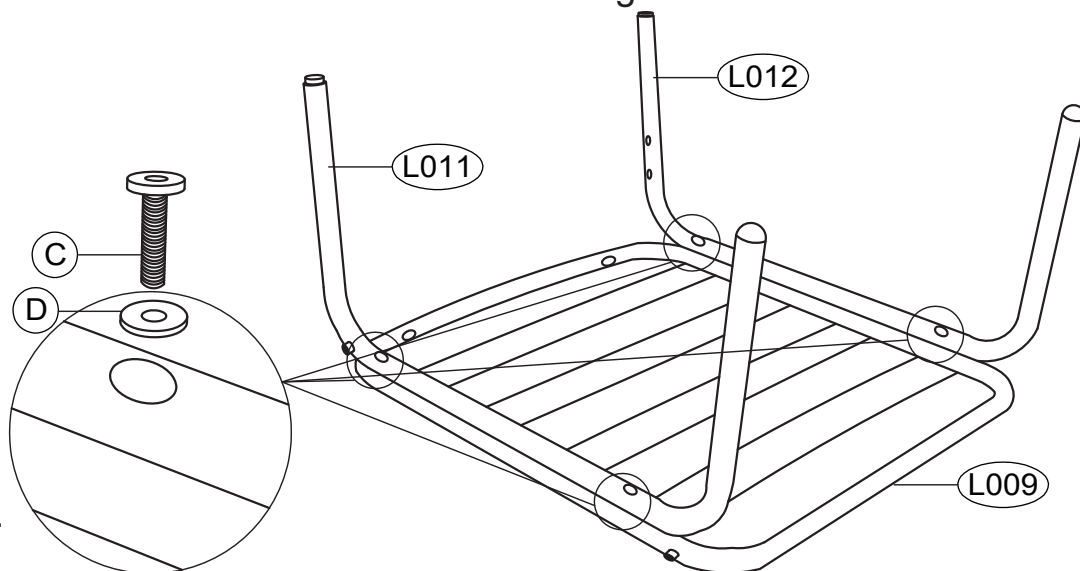

So bauen Sie den Stuhl zusammen

SCHRITT 01: Drehen Sie den Sitzrahmen (L009) um, sodass die Rückseite nach oben zeigt. Befestigen Sie das linke Bein (L011) und das rechte Bein (L012) mit Schrauben an beiden Seiten des Sitzrahmens (L009).

HINWEIS: Ziehen Sie die Schrauben nicht vollständig fest.

Die Stuhlbeine mit verstellbaren Fußpolstern sind die hinteren Beine, die näher an der Seite des Sitzrahmens mit den Löchern positioniert werden sollten.





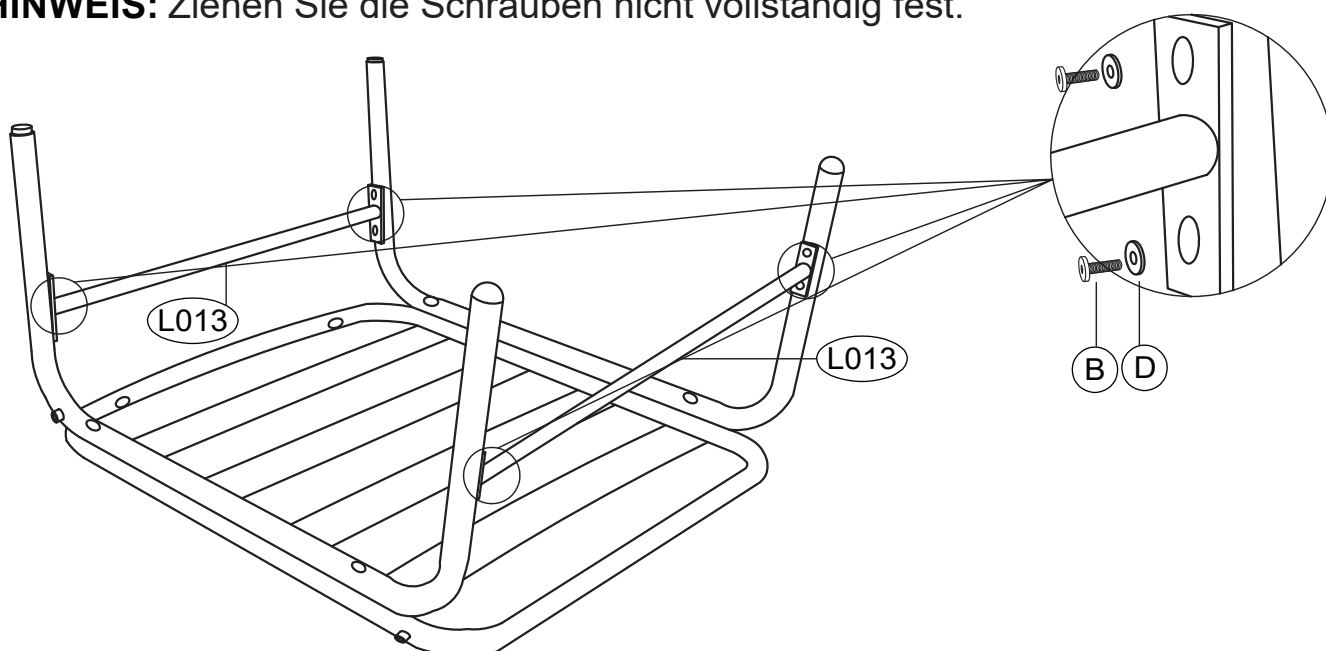

L009		x1	L011		x1	L012		x1	C		x4	D		x4	E		x1
									M6*35								

SCHRITT 02: Befestigen Sie die beiden Sitzstützstangen (L013) jeweils in der Mitte der neu installierten linken und rechten Beine und befestigen Sie sie an der Vorder- und Rückseite jedes Beins.

HINWEIS: Ziehen Sie die Schrauben nicht vollständig fest.



L013		x1	B		x8	D		x8	E		x1
				M6*15							

SCHRITT 03: Klappen Sie den Sitz wieder in seine Position zurück. Richten Sie die vorderen und hinteren Schraubenlöcher am unteren Teil der rechten Armlehne (L008) an den entsprechenden vorderen und hinteren Schraubenlöchern an der Außenseite des rechten Beins (L012) des neu installierten Sitzes aus und befestigen Sie sie dann mit Schrauben.

HINWEIS: Ziehen Sie die Schrauben nicht vollständig fest.

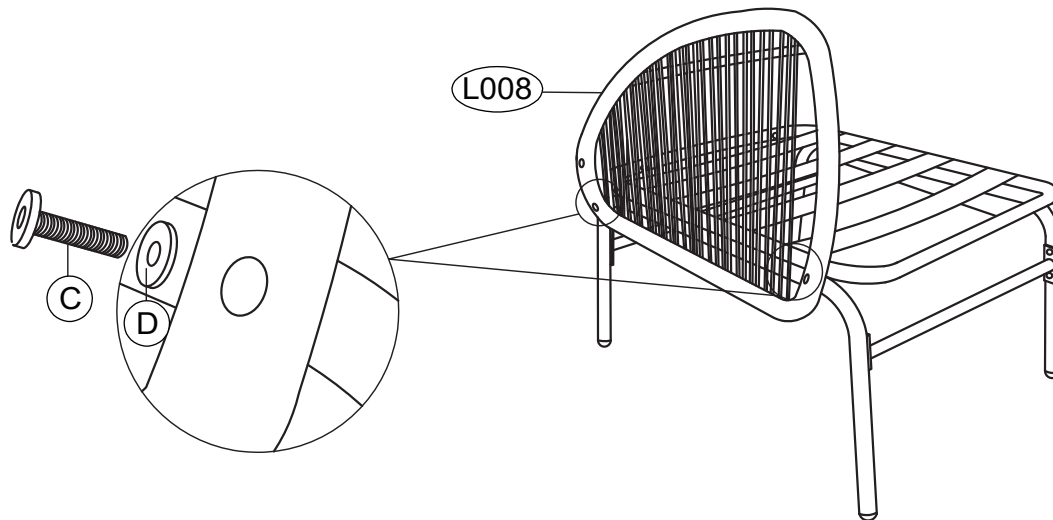

L008		x1	C		x2	D		x2	E		x1
				M6*35							

SCHRITT 04: Befestigen Sie die linke Armlehne (L007) wie im vorherigen Schritt mit Schrauben am linken Bein (L011) des Stuhls.

HINWEIS: Ziehen Sie die Schrauben nicht vollständig fest.

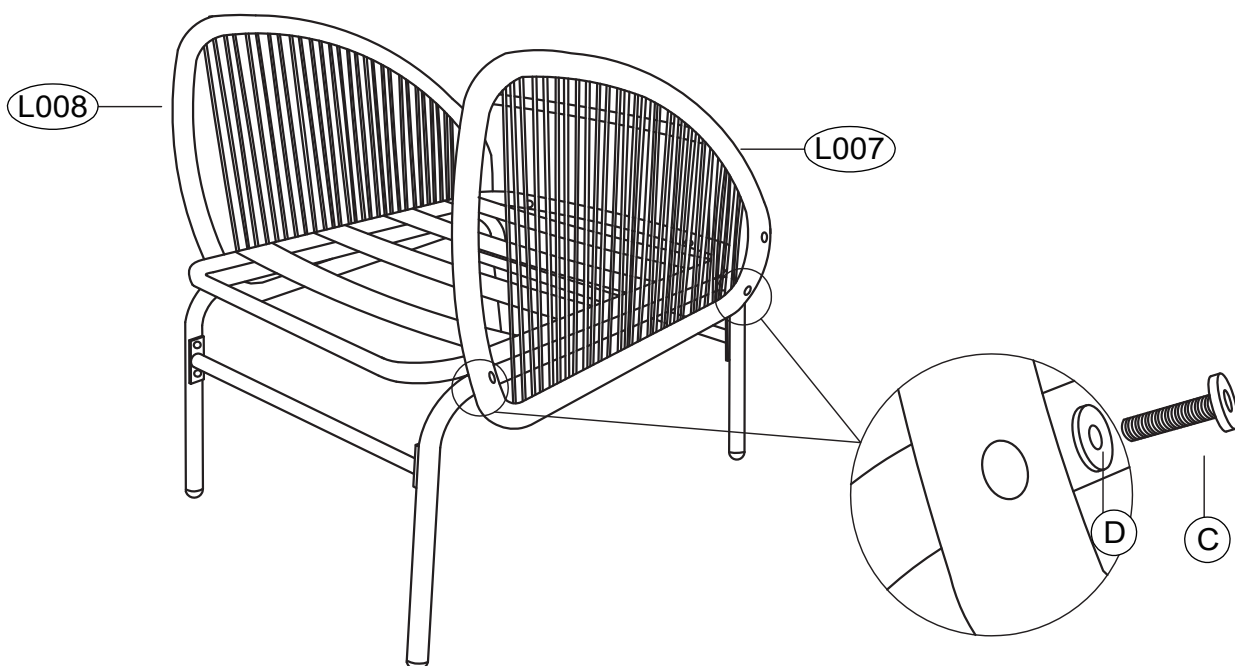



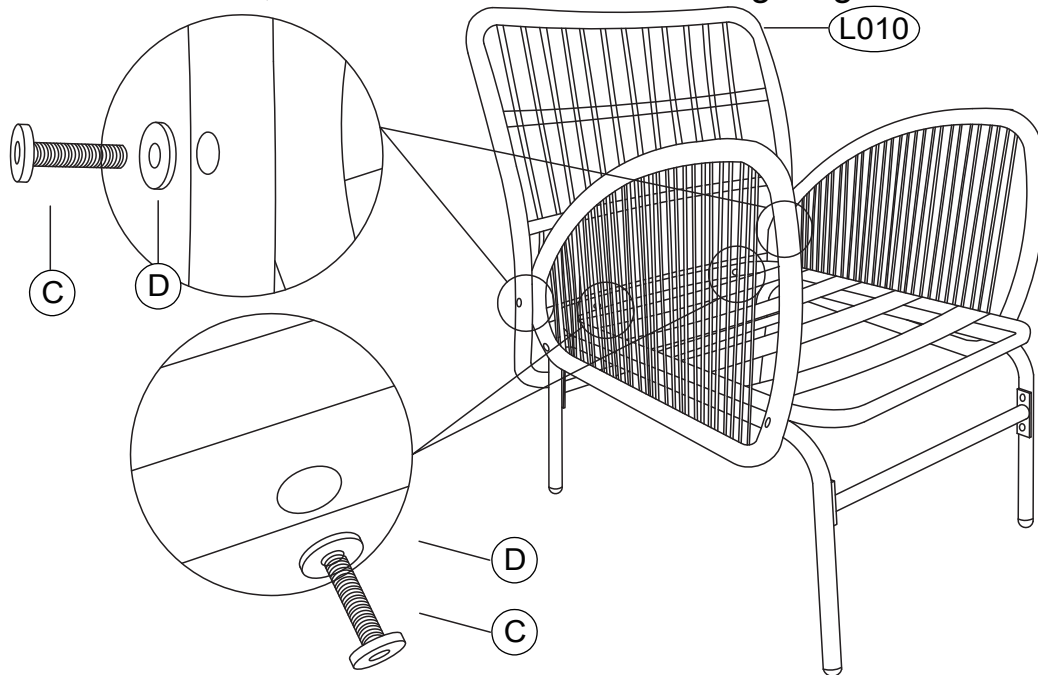

L008		x1	C		x2	D		x2	E		x1
				M6*35							

SCHRITT 05: Befestigen Sie die Rückenlehne (L010) mit Schrauben an den linken und rechten Armlehnen und am hinteren Teil des Sitzrahmens.



HINWEIS: Stellen Sie sicher, dass alle Schrauben fest angezogen sind.

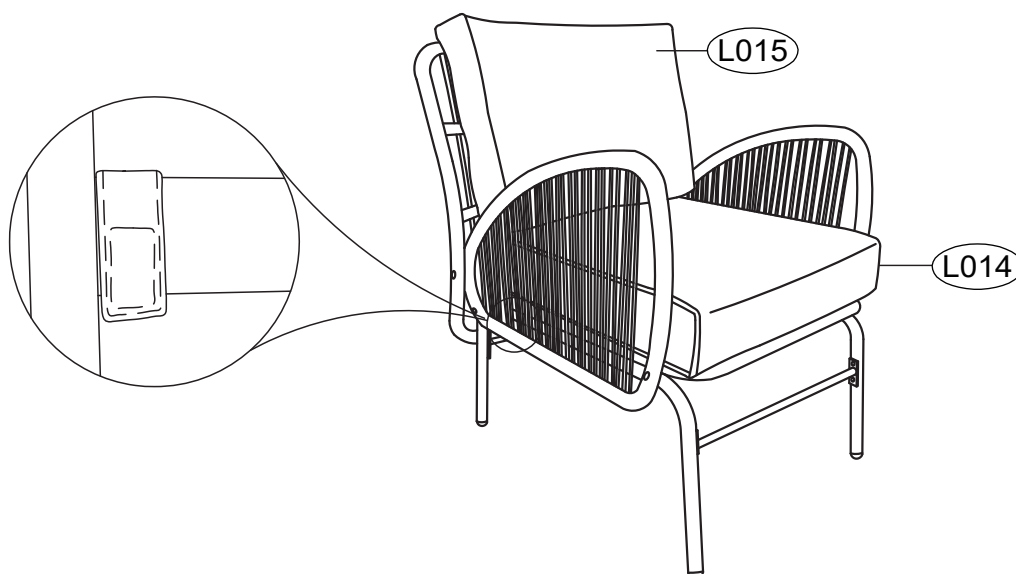

L010		x1	C		x4	D		x4	E		x1
				M6*35							

SCHRITT 06: Legen Sie das Sitzkissen (L014) und das Rückenkissen (L015) auf den neu zusammengebauten Stuhl. Befestigen Sie das Sitzkissen (L014) mit den Klettverschlüssen an der Unterseite des Kissens am Metallrahmen.



L014		x2	L015		x2
------	---	----	------	---	----

Ensemble de 3 fauteuils lounge en corde

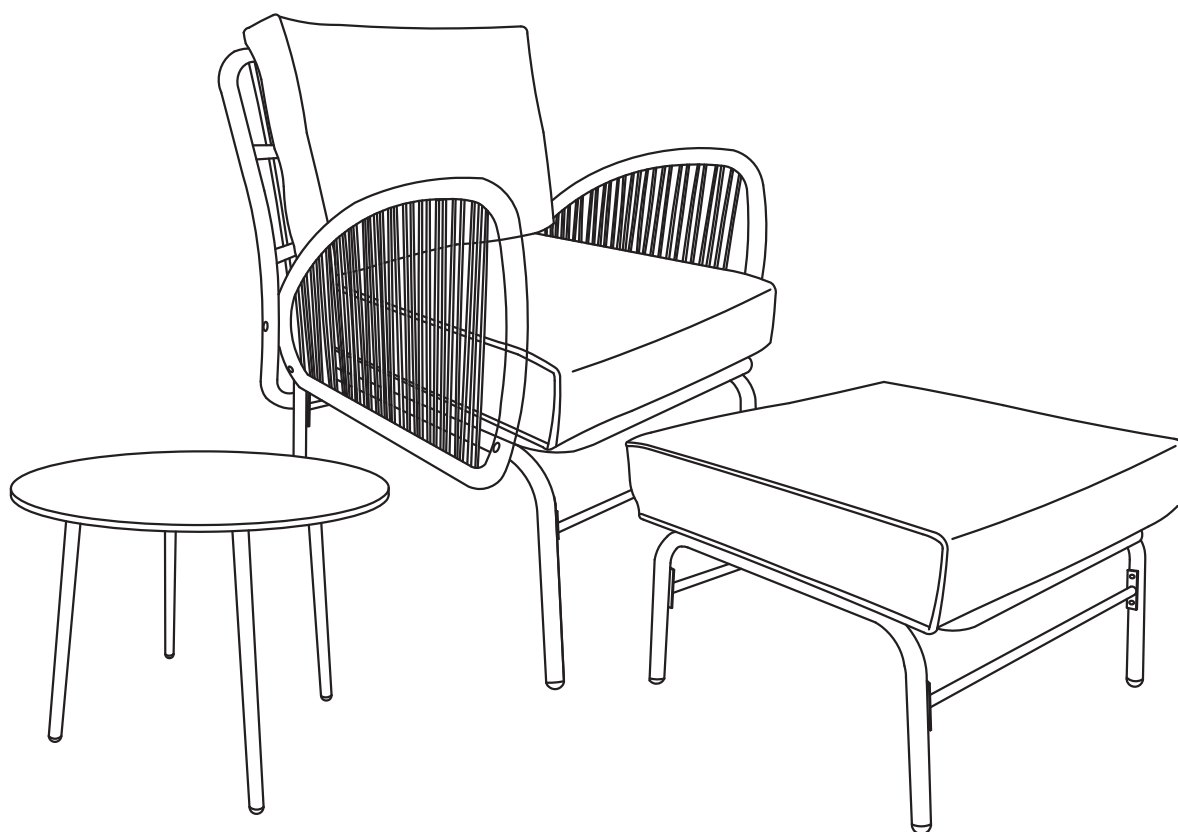

IMPORTANT

VEUILLEZ LIRE AVANT DE COMMENCER L'ASSEMBLAGE

Suivez les instructions contenues dans ce guide d'utilisation afin d'assurer un assemblage et un entretien corrects de ce produit.

Ensemble de 3 fauteuils lounge en corde

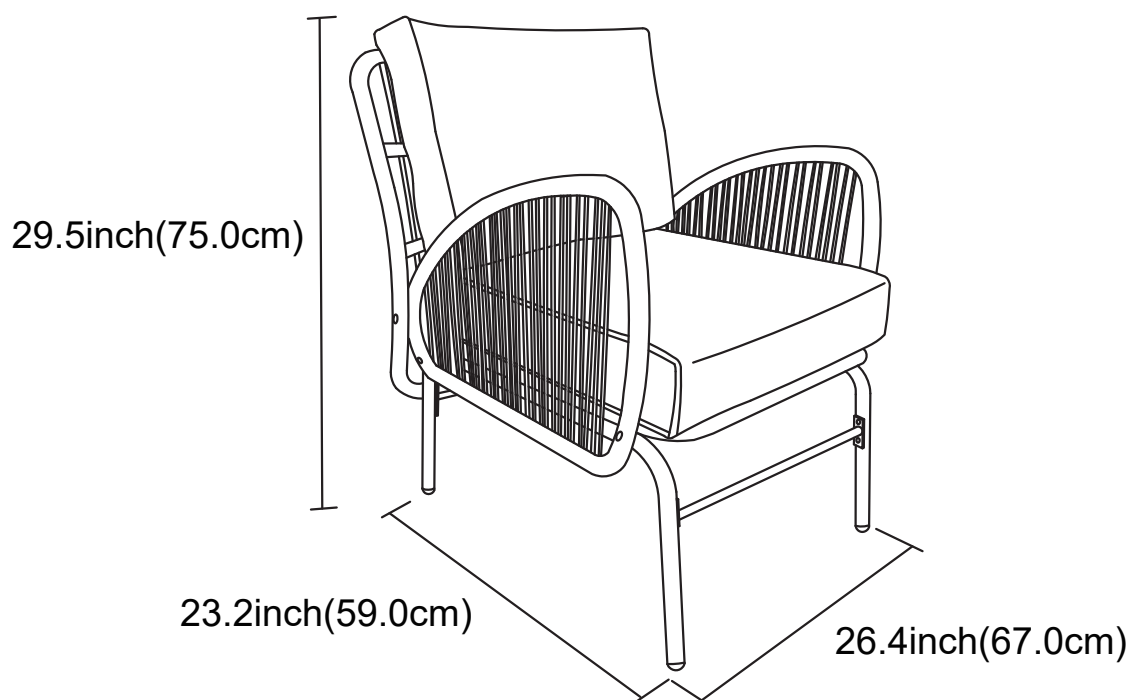
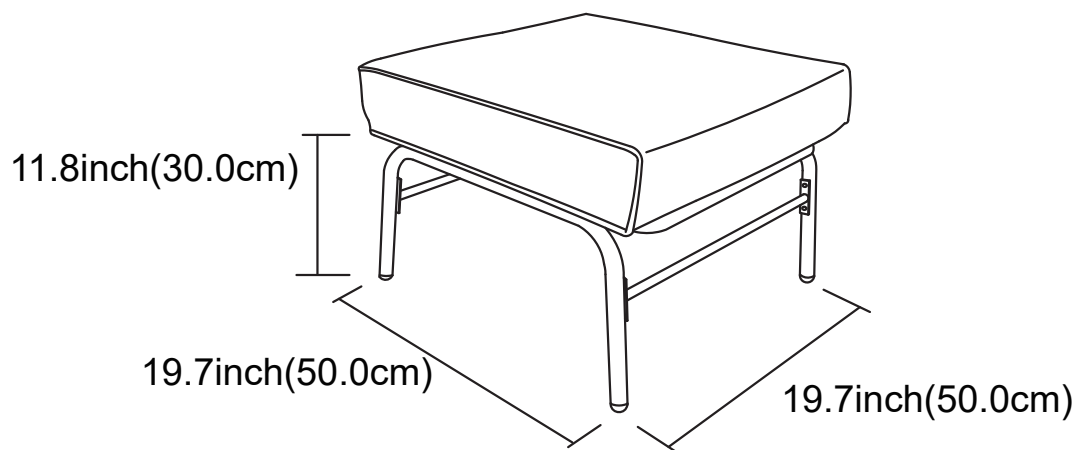
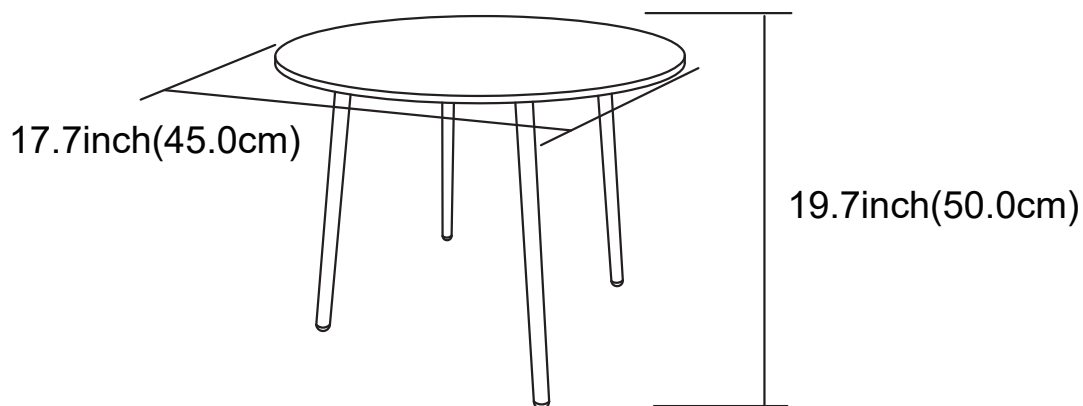

Catalogue

Spécifications.....	01
Catalogue.....	02
Avis.....	03
Liste des pièces et liste des vis.....	04
Comment assembler la table d'appoint.....	05
Comment assembler le repose-pieds.....	06
Comment assembler la chaise.....	08



Avant de commencer







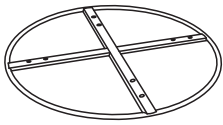

Les instructions fournies dans ce manuel contiennent toutes les informations nécessaires concernant votre produit.

Veillez lire attentivement toutes les instructions avant de commencer et, pendant l'assemblage, suivez scrupuleusement les étapes indiquées afin d'obtenir un résultat correct.

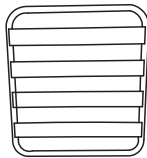
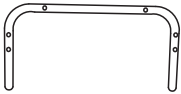

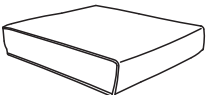
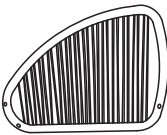
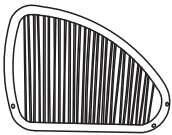
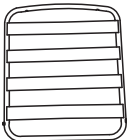

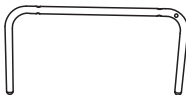
1. Toutes les pièces sont emballées dans le carton. Triez le contenu du carton par numéro de pièce tout en consultant la liste des pièces. Vérifiez que vous disposez de toutes les pièces nécessaires à la construction.
2. Familiarisez-vous avec le matériel et les fixations afin de faciliter leur utilisation pendant la construction.
3. Les premières étapes montrent comment assembler les pièces connexes afin d'obtenir des sous-ensembles plus grands qui seront utilisés ultérieurement.
4. Veuillez noter que des fixations supplémentaires ont été fournies pour votre commodité.
5. Si vous disposez d'un tournevis électrique, vous pouvez l'utiliser à la place du tournevis que nous fournissons. Un tournevis électrique peut vous aider à réduire le temps d'assemblage.

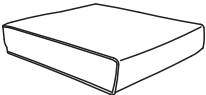
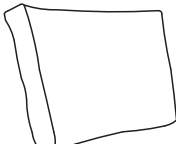
LISTE DES PIÈCES

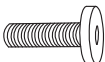

Liste des pièces

L001 	L002 	L003 	L004 
1PC	4PCS	1PC	2PCS
L005 	L006 	L007 	L008 
2PCS	1PC	1PC	1PC
L009 	L010 	L011 	L012 
1PC	1PC	1PC	1PC
L013 	L014 	L015 	
2PCS	1PC	1PC	

Jeu de vis

A 	B 	C 	D 	E 
M6*12	M6*15	M6*35	M6	4*4
8PCS	16PCS	16PCS	40PCS	1PC

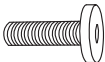
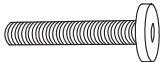
Supplément (jeu de vis)

A 	B 	C 	D 	
M6*12	M6*15	M6*35	M6	
1PC	2PCS	2PCS	5PCS	

Comment assembler la table d'appoint

ÉTAPE 01 : Retournez le plateau (L001) afin que la face inférieure soit tournée vers le haut, puis fixez les pieds de table (L002) au plateau à l'aide de vis.

REMARQUE : Lorsque vous fixez chaque pied, serrez les deux vis simultanément. Enfin, assurez-vous que toutes les vis sont bien serrées.

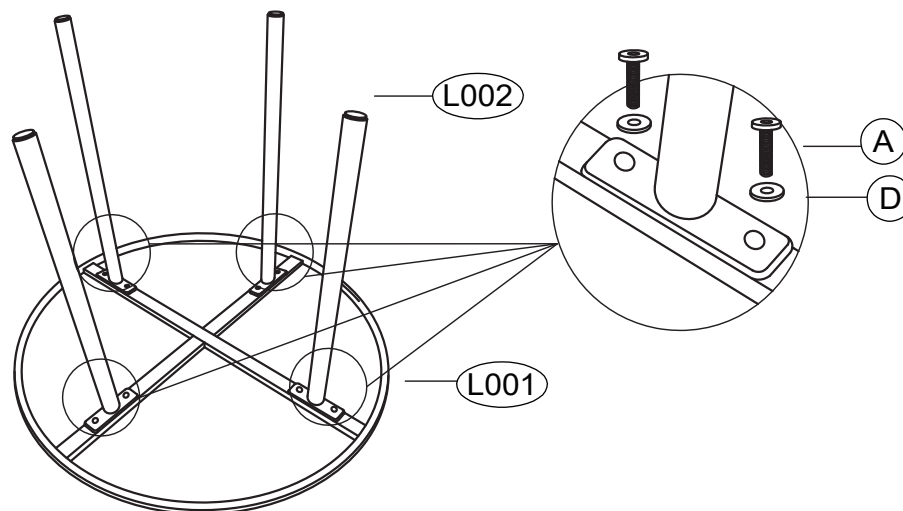

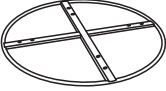
L001		x2	L002		x1	A		x8	D		x8	E		x1
							M6*12							

ÉTAPE 02 : Remettez le plateau en place et tournez les pieds réglables pour stabiliser la table.

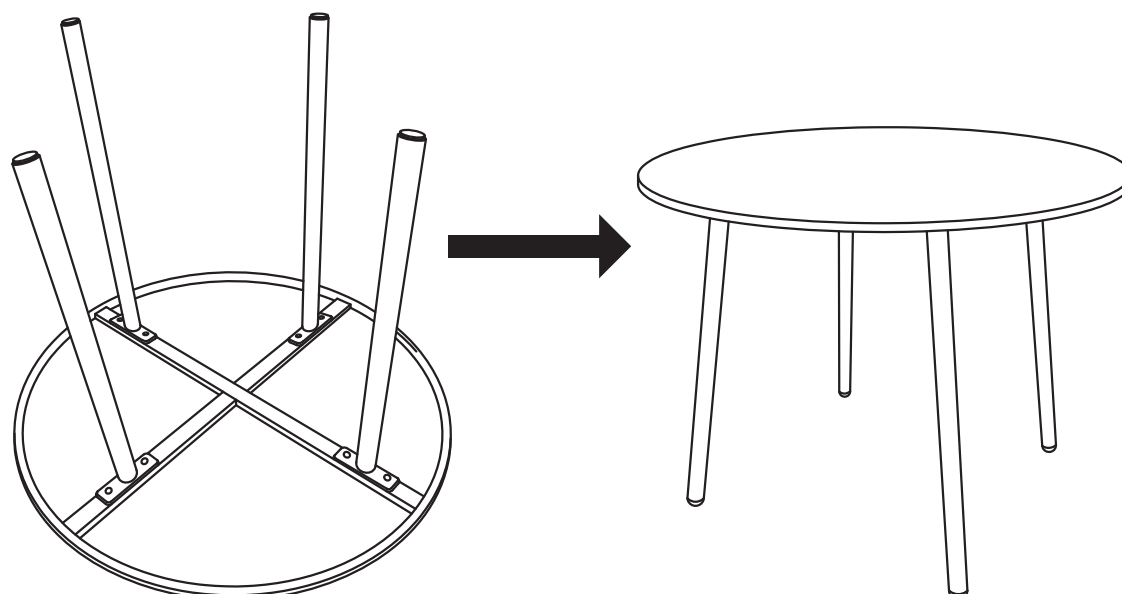



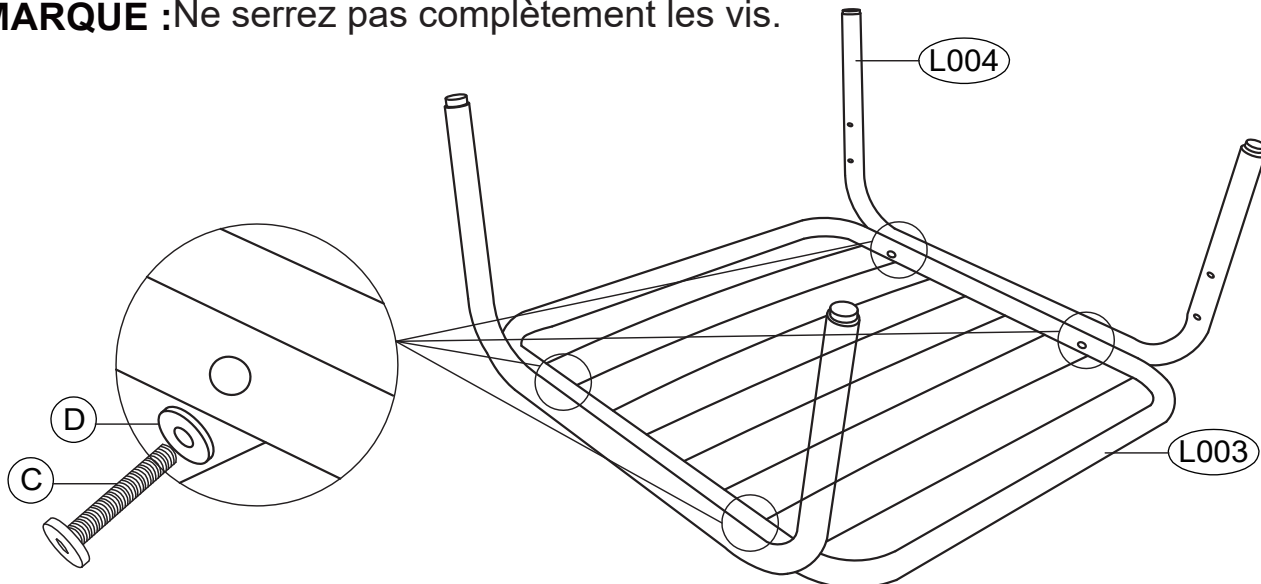

Comment assembler le repose-pieds

ÉTAPE 01 : Retournez le cadre du repose-pieds (L003) afin que l'envers soit tourné vers le haut. Fixez les pieds du repose-pieds (L004) aux côtés gauche et droit du cadre du repose-pieds (L003) à l'aide de vis.

REMARQUE : Ne serrez pas complètement les vis.





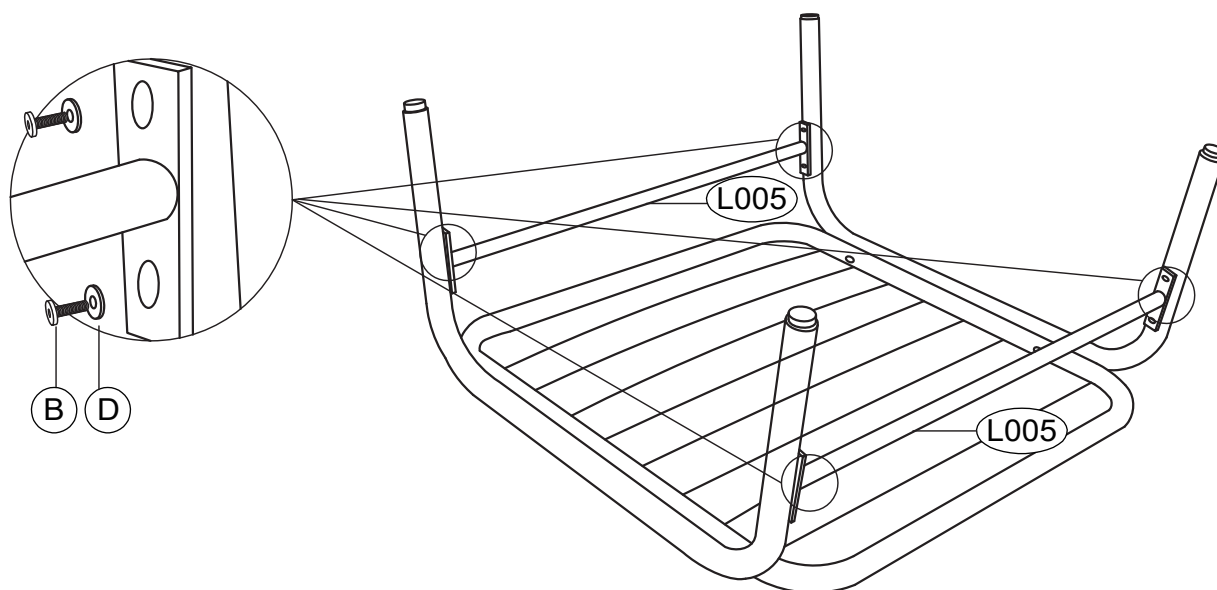

L003		x1	L004		x2	C		M6*35	x4	D		x4	E		x1
------	---	----	------	---	----	---	---	-------	----	---	---	----	---	---	----

ÉTAPE 02 : Fixez les deux tiges de support du repose-pieds (L005) au centre des deux pieds nouvellement installés, en les fixant à l'avant et à l'arrière de chaque pied.

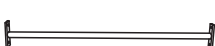
REMARQUE : Assurez-vous que toutes les vis sont bien serrées.



L005		x2	B		M6*15	x8	D		x8	E		x1
------	---	----	---	---	-------	----	---	---	----	---	---	----

Étapes d'installation

ÉTAPE 03 : Remettez le repose-pieds en place. Placez le coussin du repose-pieds (L006) sur le repose-pieds nouvellement installé, en le fixant au cadre métallique à l'aide des attaches Velcro situées sous le coussin.

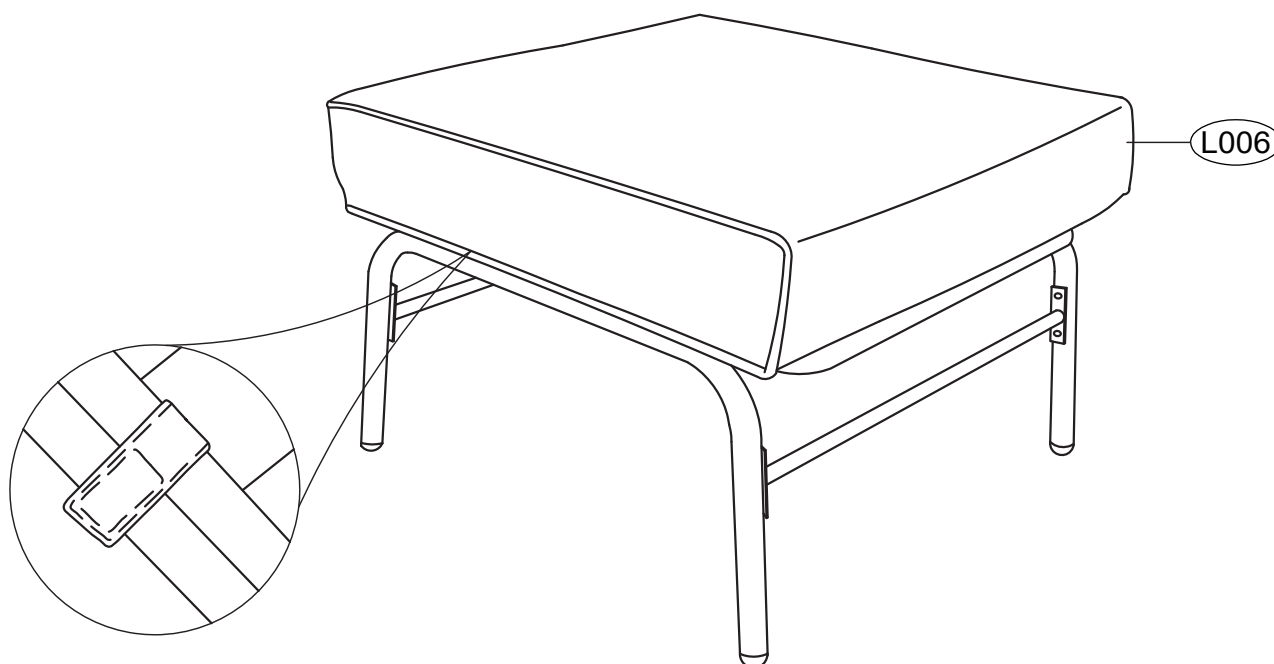

L006

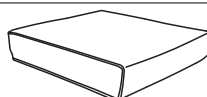

x1





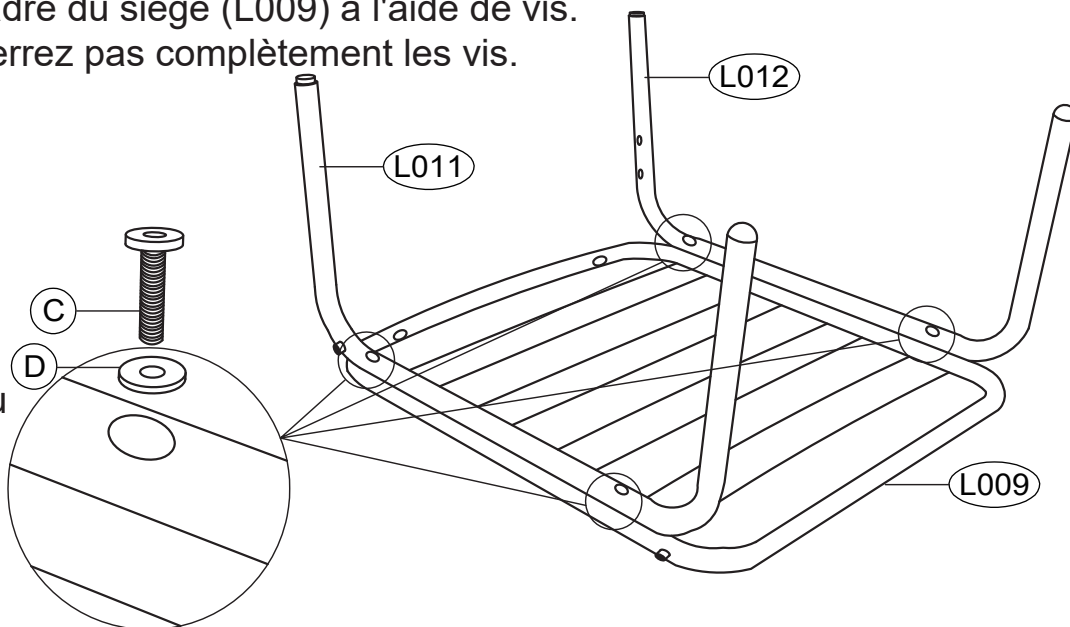

Comment assembler la chaise

ÉTAPE 01 : Retournez le cadre du siège (L009) afin que l'envers soit tourné vers le haut. Fixez les pieds gauche (L011) et droit (L012) de chaque côté du cadre du siège (L009) à l'aide de vis.

REMARQUE : Ne serrez pas complètement les vis.

Les pieds arrière de la chaise, équipés de patins réglables, doivent être placés plus près du côté du cadre du siège où se trouvent les trous.





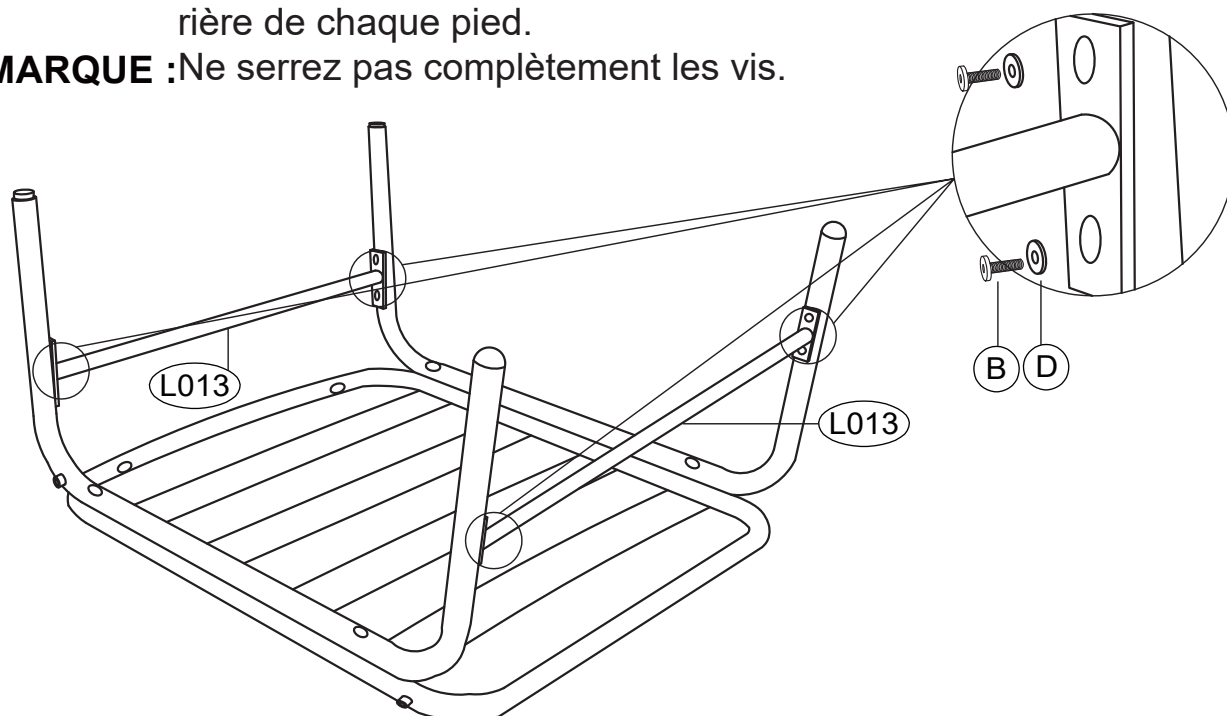

L009		x1	L011		x1	L012		x1	C		x4	D		x4	E		x1
									M6*35								

ÉTAPE 02 : Fixez les deux tiges de support de siège (L013) au centre des pieds gauche et droit nouvellement installés, en les fixant à l'avant et à l'arrière de chaque pied.

REMARQUE : Ne serrez pas complètement les vis.







L013		x1	B		x8	D		x8	E		x1
				M6*15							

Étapes d'installation

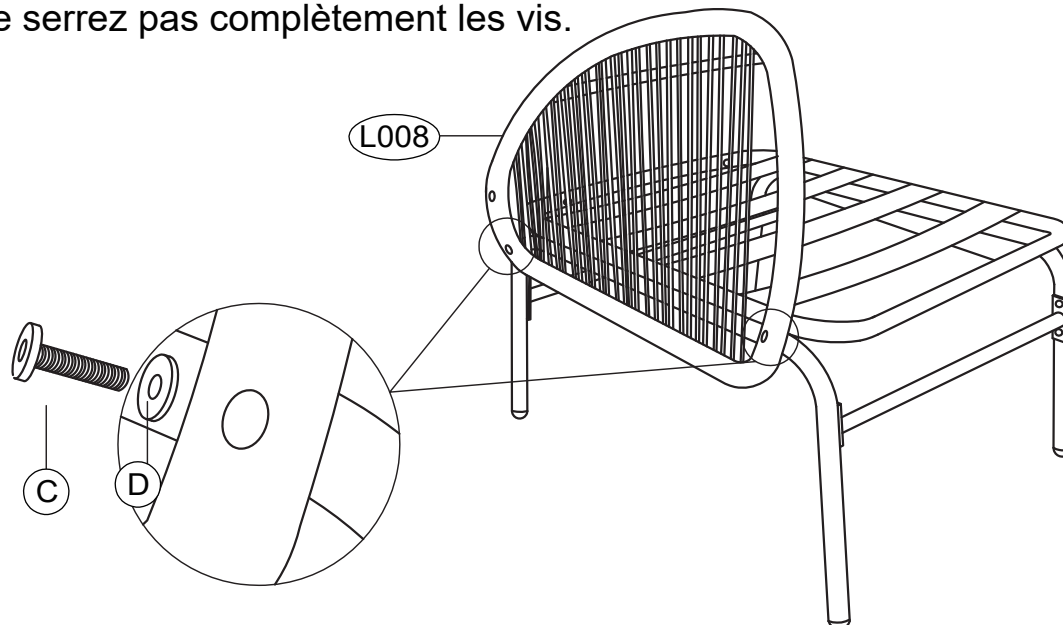
ÉTAPE 03 : Remettez le siège en place. Alignez les trous de vis avant et arrière situés sur la partie inférieure de l'accoudoir droit (L008) avec les trous de vis avant et arrière correspondants situés sur le côté extérieur du pied droit (L012) du siège nouvellement installé, puis fixez-les à l'aide de vis.

REMARQUE : Ne serrez pas complètement les vis.

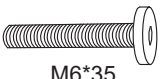



L008		x1	C		x2	D		x2	E		x1
				M6*35							

ÉTAPE 04 : De la même manière que lors de l'étape précédente, fixez l'accoudoir gauche (L007) à la jambe gauche (L011) du fauteuil à l'aide de vis.

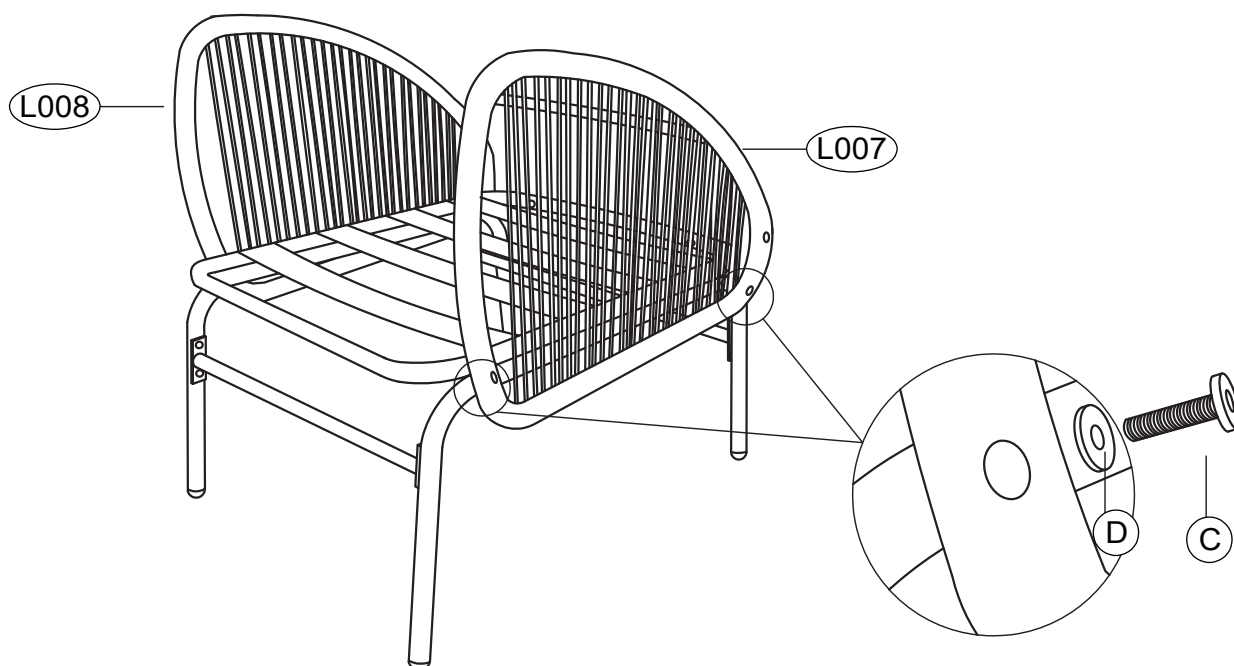
REMARQUE : Ne serrez pas complètement les vis.

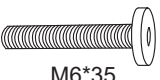





L008		x1	C		x2	D		x2	E		x1
				M6*35							

Étapes d'installation

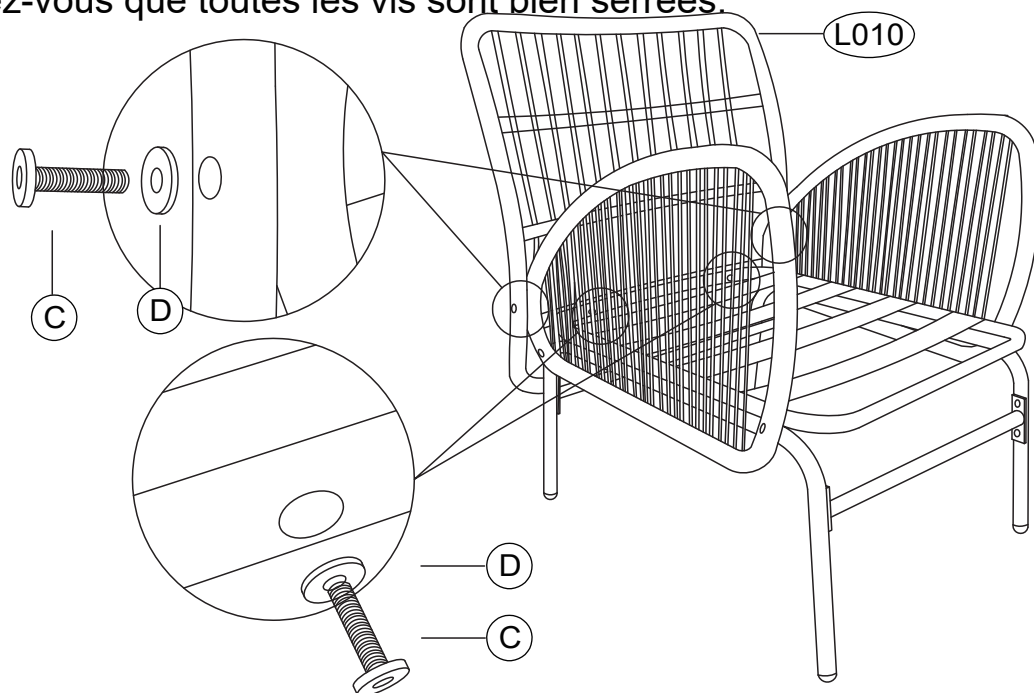
ÉTAPE 05 : Fixez le dossier du siège (L010) aux accoudoirs gauche et droit et à la partie arrière du cadre du siège à l'aide de vis.



REMARQUE : Assurez-vous que toutes les vis sont bien serrées.

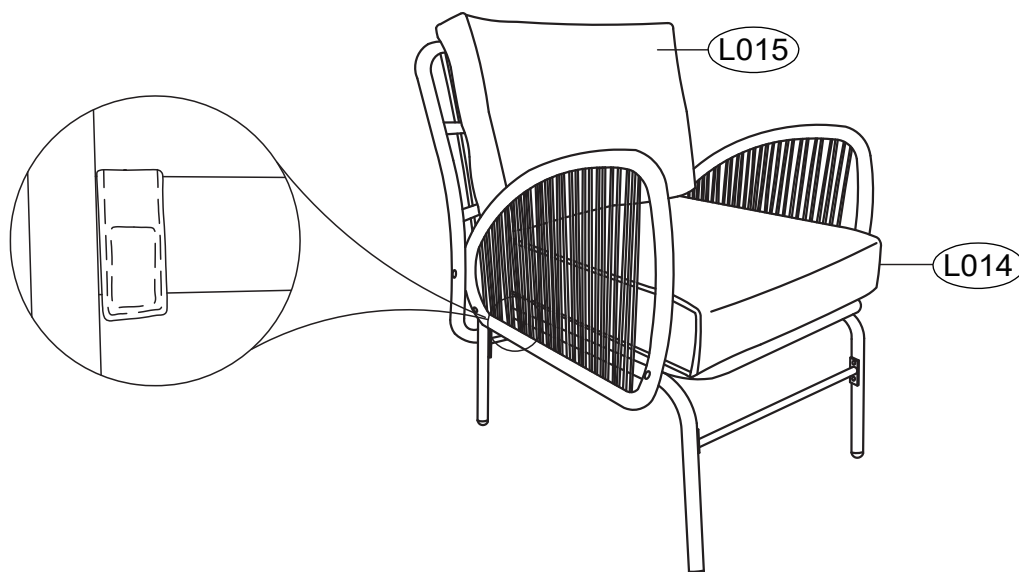

L010		x1	C		x4	D		x4	E		x1
				M6*35							

ÉTAPE 06 : Placez le coussin d'assise (L014) et le coussin de dossier (L015) sur la chaise nouvellement assemblée. Fixez le coussin d'assise (L014) au cadre métallique à l'aide des attaches Velcro situées sous le coussin.



L014		x2	L015		x2
------	---	----	------	---	----

Conjunto de 3 sillones de cuerda

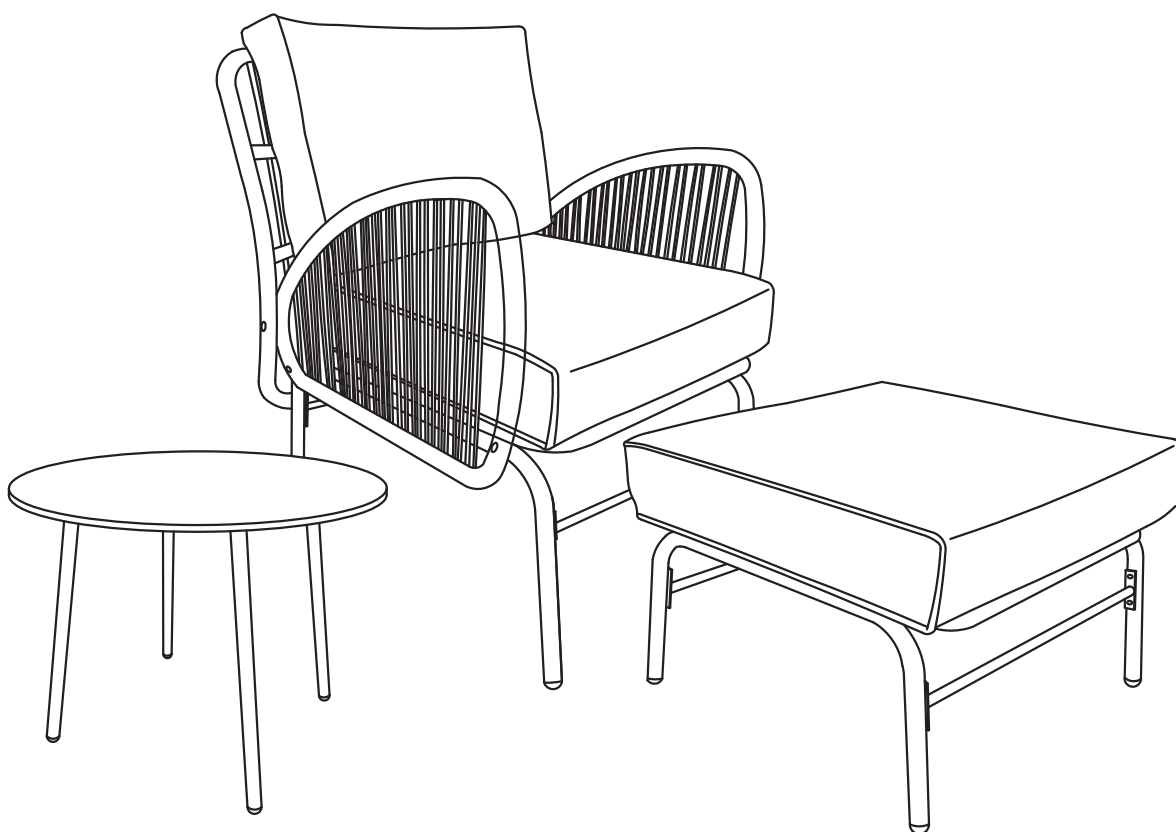

IMPORTANTE

LEA ANTES DE COMENZAR EL MONTAJE

Siga las instrucciones de esta guía del usuario para garantizar el montaje y cuidado correctos de este producto.

Conjunto de 3 sillones de cuerda

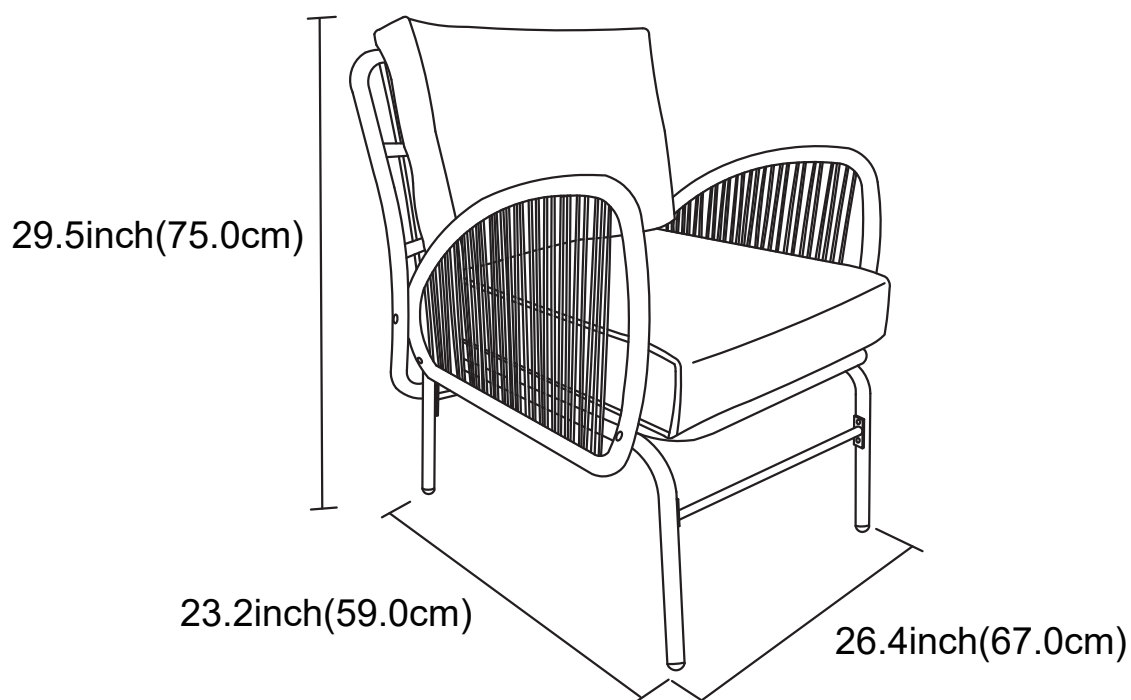
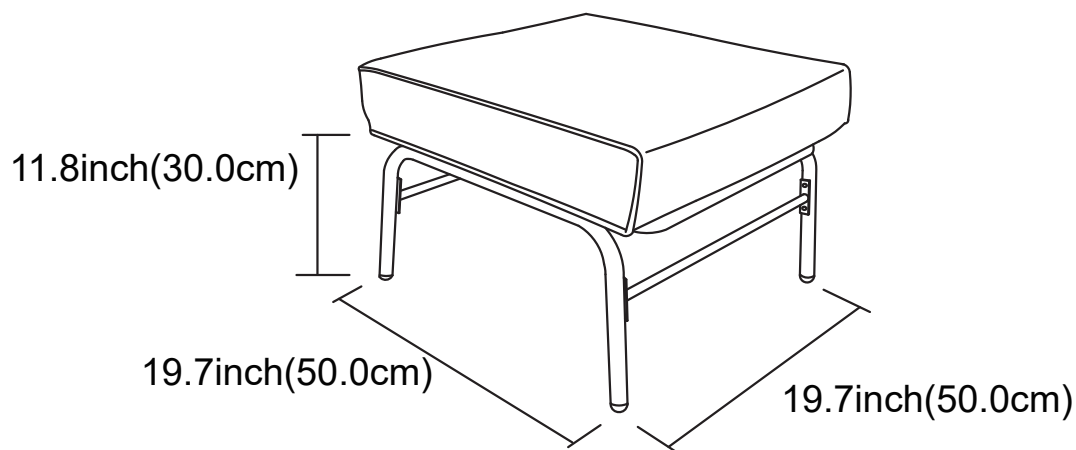
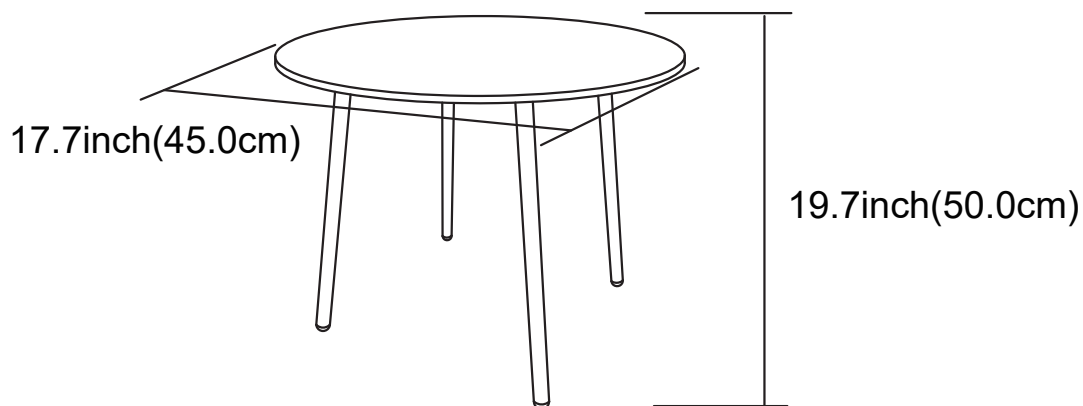

Catálogo

Especificaciones..... 01

Catálogo..... 02

Aviso..... 03

Lista de piezas y lista de tornillos..... 04

Cómo montar la mesa auxiliar..... 05

Cómo montar el reposapiés..... 06

Cómo montar la silla..... 08



Antes de comenzar







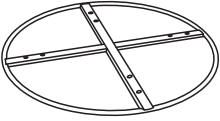
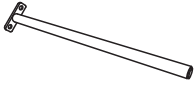
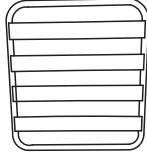

Las instrucciones se proporcionan en este manual y contienen toda la información pertinente para su producto.

Revise todas las instrucciones antes de comenzar y, durante el montaje, siga cuidadosamente la secuencia de pasos para obtener resultados correctos.

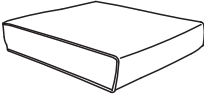
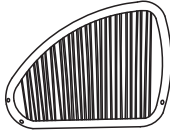
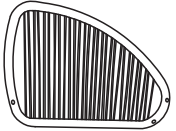

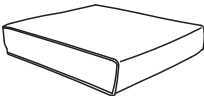
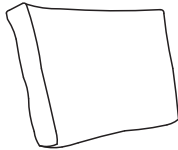

1. Todas las piezas están embaladas dentro de la caja de cartón. Separe el contenido de la caja por número de pieza mientras revisa la lista de piezas. Compruebe que tiene todas las piezas necesarias para el montaje.
2. Familiarícese con los herrajes y los elementos de fijación para facilitar su uso durante el montaje.
3. Los primeros pasos muestran cómo unir las piezas relacionadas para obtener subconjuntos más grandes que se utilizarán más adelante.
4. Tenga en cuenta que se han suministrado sujetadores adicionales para su comodidad.
5. Si dispone de un destornillador eléctrico, puede utilizarlo en lugar del destornillador que le proporcionamos. Un destornillador eléctrico puede ayudarle a reducir el tiempo de montaje.

LISTA DE PIEZAS

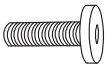

Lista de piezas

L001 	L002 	L003 	L004 
1PC	4PCS	1PC	2PCS
L005 	L006 	L007 	L008 
2PCS	1PC	1PC	1PC
L009 	L010 	L011 	L012 
1PC	1PC	1PC	1PC
L013 	L014 	L015 	
2PCS	1PC	1PC	

Juego de tornillos

A 	B 	C 	D 	E 
M6*12	M6*15	M6*35	M6	4*4
8PCS	16PCS	16PCS	40PCS	1PC

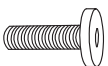
Extra (juego de tornillos)

A 	B 	C 	D 	
M6*12	M6*15	M6*35	M6	
1PC	2PCS	2PCS	5PCS	

Cómo montar la mesa auxiliar

PASO 01: Dé la vuelta al tablero (L001) para que la parte inferior quede hacia arriba y, a continuación, fije las patas de la mesa (L002) al tablero con tornillos.

NOTA: Al fijar cada pata, apriete ambos tornillos simultáneamente. Por último, asegúrese de que todos los tornillos estén bien apretados.

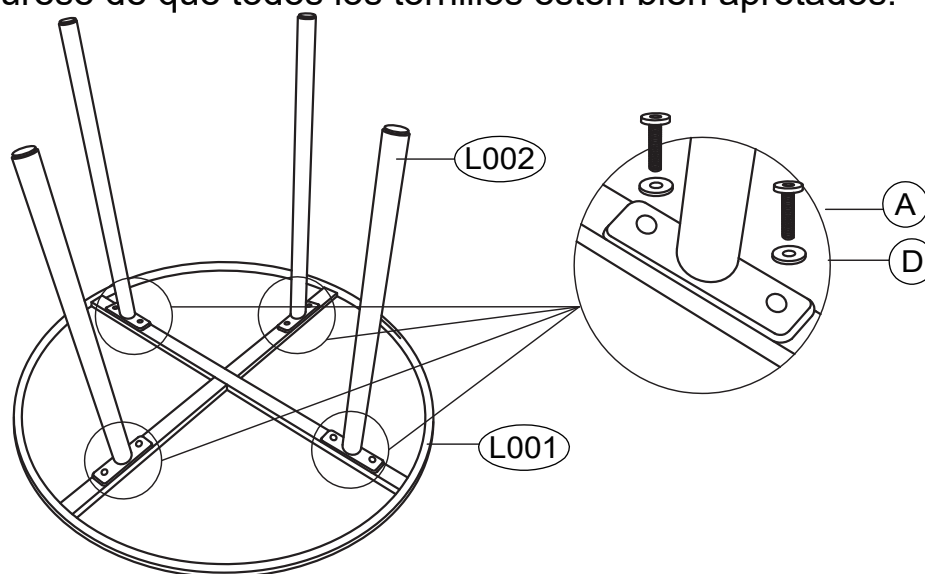

L001		x2	L002		x1	A		x8	D		x8	E		x1
							M6*12							

PASO 02: Vuelva a colocar el tablero en su posición y gire las patas ajustables para estabilizar la mesa.

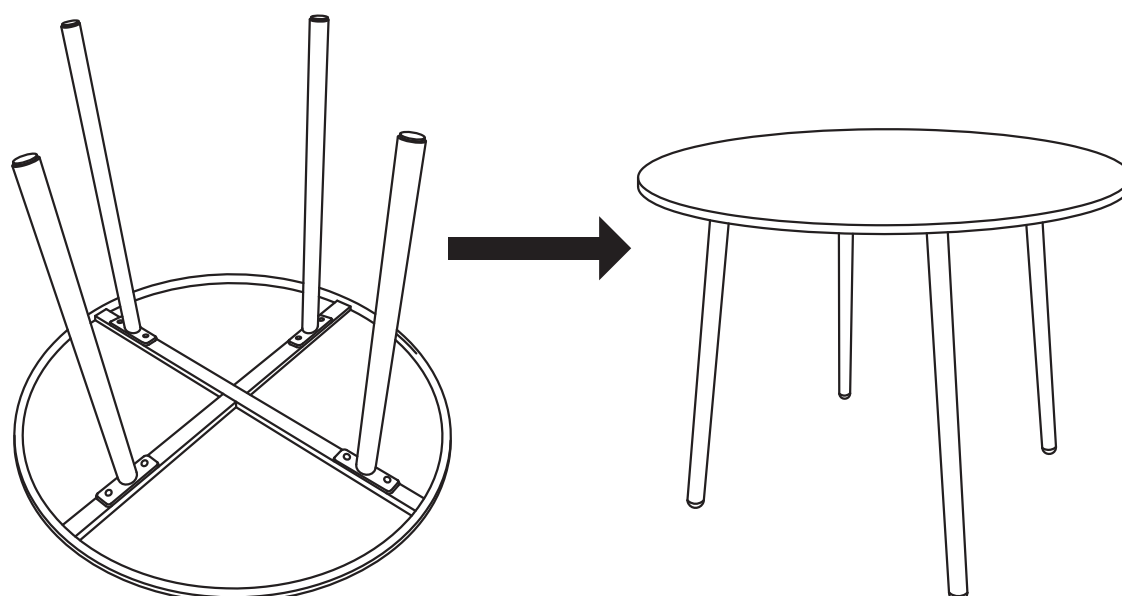



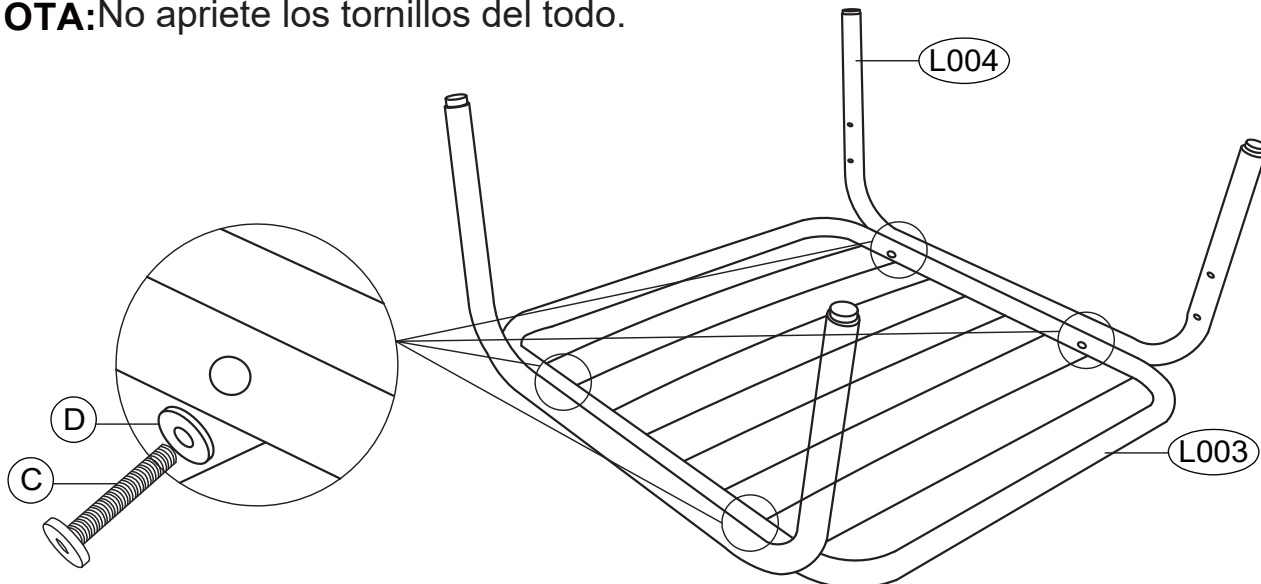

Cómo montar el reposapiés

PASO 01: Dé la vuelta al bastidor del reposapiés (L003) de modo que el reverso quede hacia arriba. Fije la pata del reposapiés (L004) a los lados izquierdo y derecho del bastidor del reposapiés (L003) con tornillos.

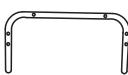
NOTA: No apriete los tornillos del todo.





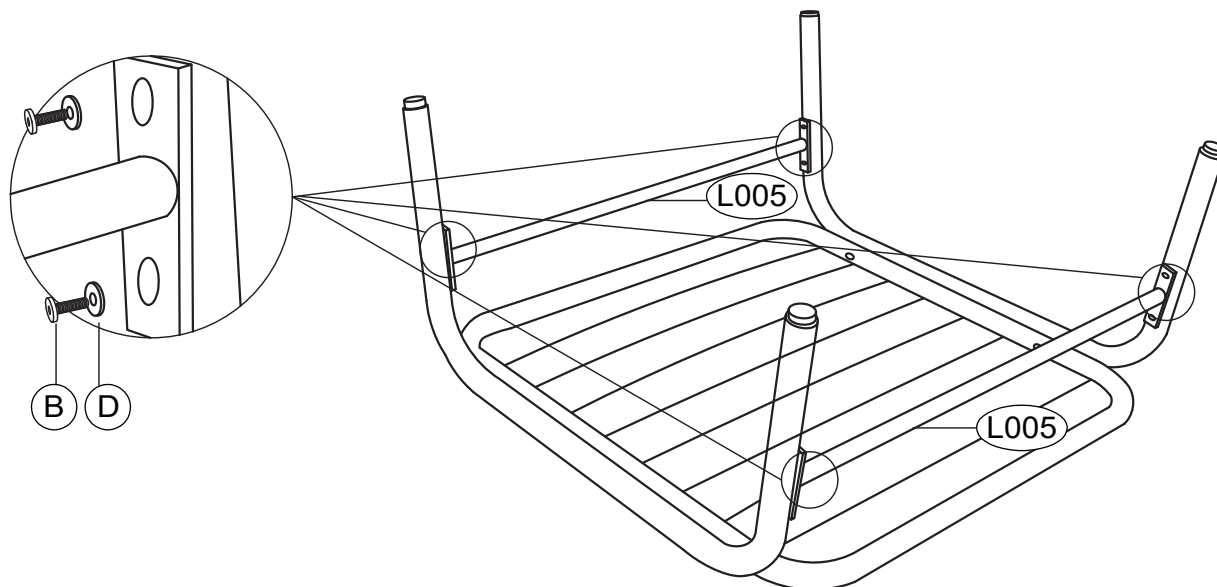

L003		x1	L004		x2	C		x4	D		x4	E		x1
							M6*35							

PASO 02: Fije las dos barras de soporte del reposapiés (L005) al centro de las dos patas recién instaladas, fijándolas a la parte delantera y trasera de cada pata.

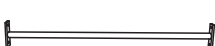
NOTA: Asegúrese de que todos los tornillos estén completamente apretados.



L005		x2	B		x8	D		x8	E		x1
				M6*15							

PASO 03: Vuelva a colocar el reposapiés en su posición. Coloque el cojín del reposapiés (L006) sobre el reposapiés recién instalado, fijándolo al marco metálico con los cierres de velcro situados en la parte inferior del cojín.

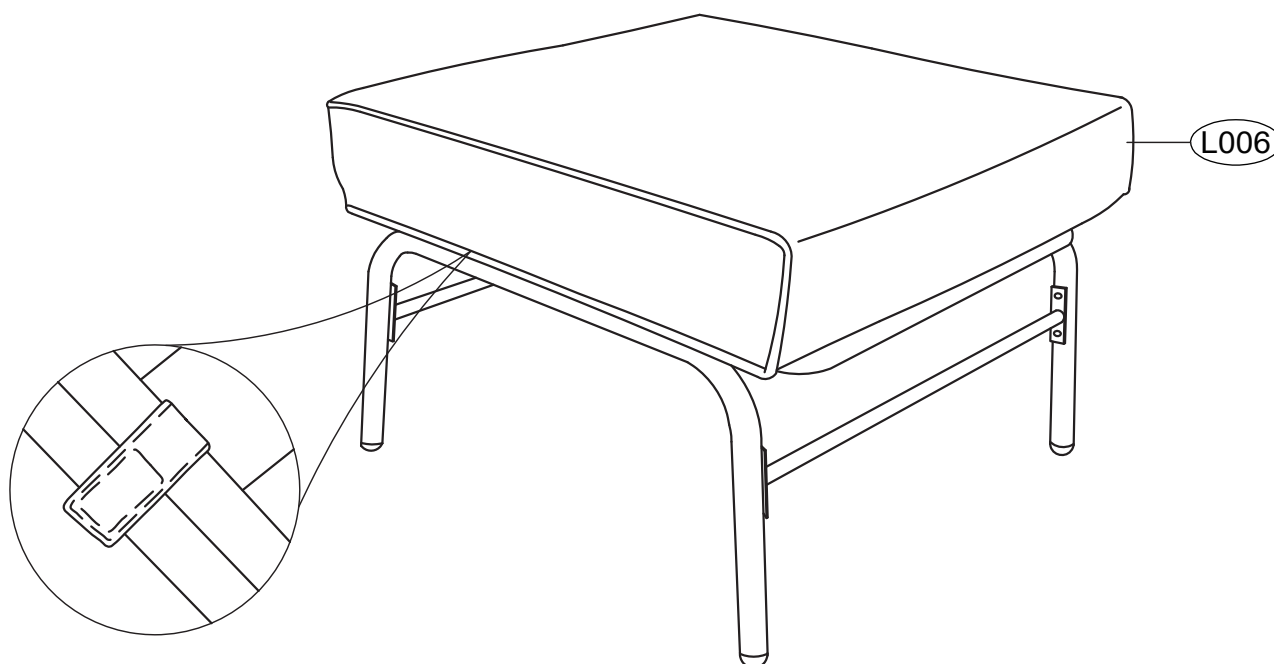

L006

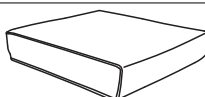

x1





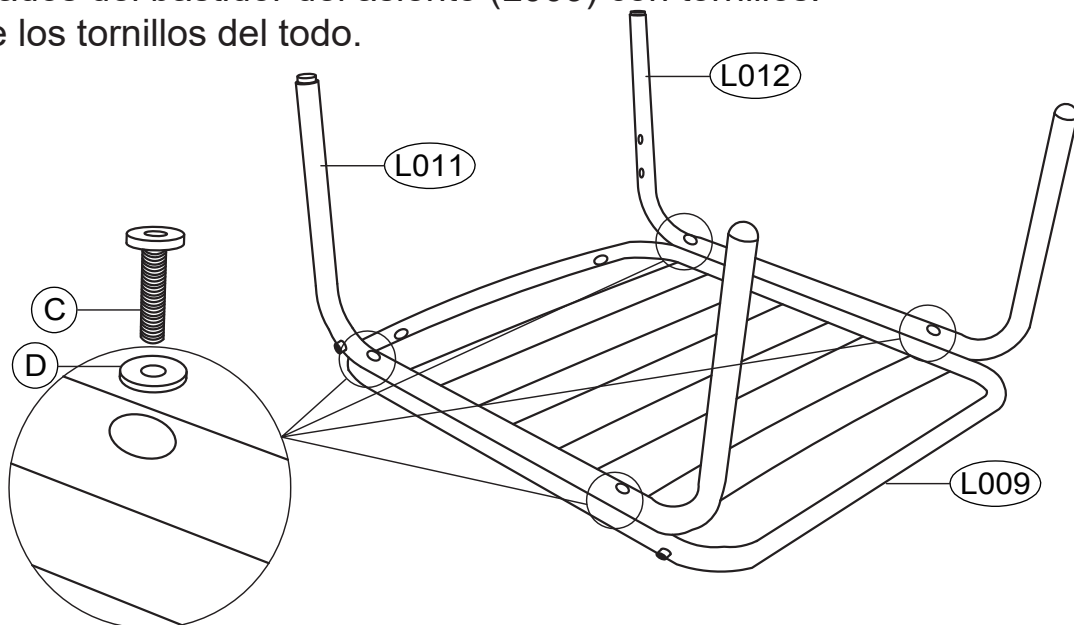

Cómo montar la silla

PASO 01: Dé la vuelta al bastidor del asiento (L009) de modo que la parte posterior quede hacia arriba. Fije la pata izquierda (L011) y la pata derecha (L012) a ambos lados del bastidor del asiento (L009) con tornillos.

NOTA: No apriete los tornillos del todo.

Las patas de la silla equipadas con almohadillas ajustables son las patas traseras, que deben colocarse más cerca del lado del armazón del asiento que tiene los orificios.





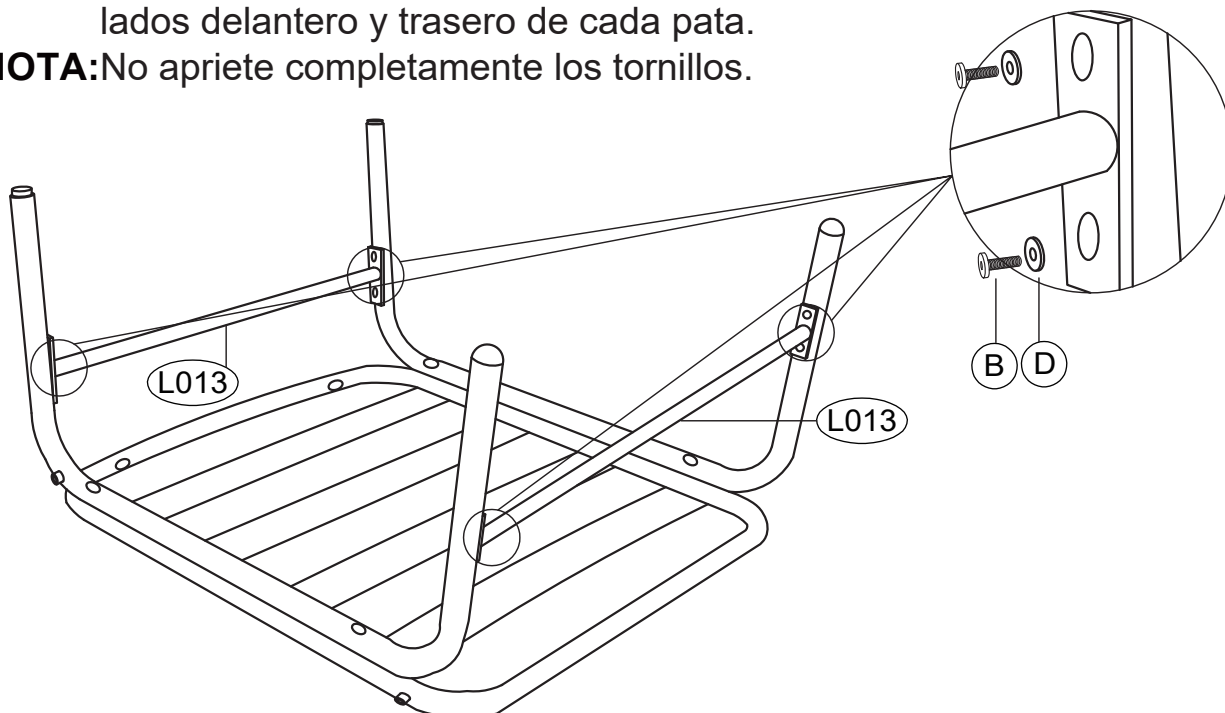

L009		x1	L011		x1	L012		x1	C		x4	D		x4	E		x1
									M6*35								

PASO 02: Fije las dos barras de soporte del asiento (L013) al centro de las patas izquierda y derecha recién instaladas, respectivamente, fijándolas a los lados delantero y trasero de cada pata.

NOTA: No apriete completamente los tornillos.







L013		x1	B		x8	D		x8	E		x1
				M6*15							

Pasos de instalación

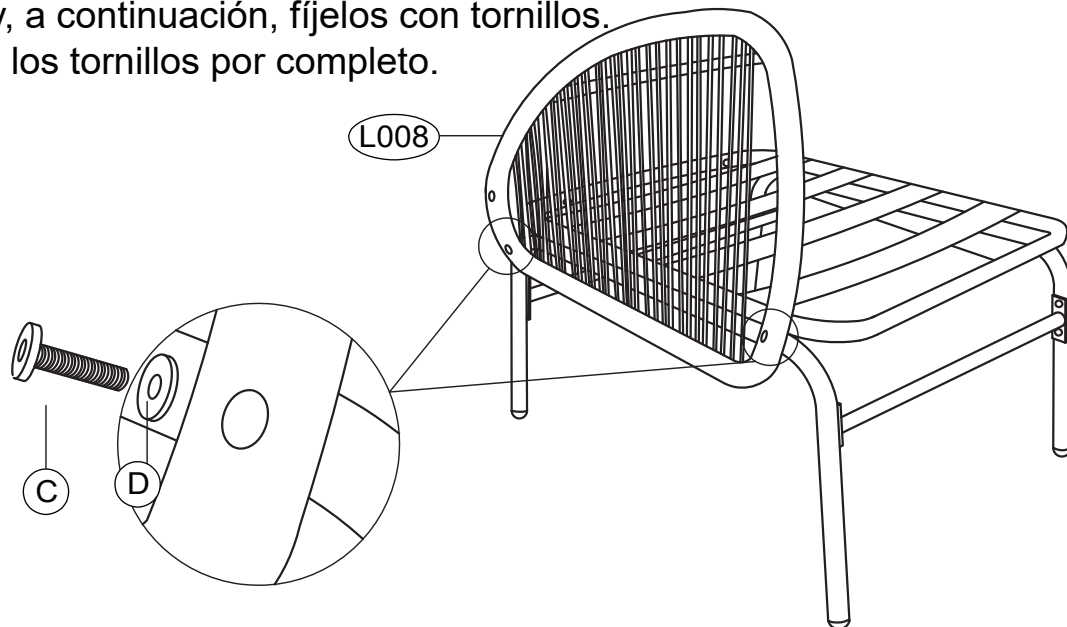
PASO 03: Vuelva a colocar el asiento en su posición. Alinee los orificios para tornillos delanteros y traseros de la sección inferior del reposabrazos derecho (L008) con los orificios para tornillos delanteros y traseros correspondientes del lado exterior de la pata derecha (L012) del asiento recién instalado y, a continuación, fíjelos con tornillos.

NOTA: No apriete los tornillos por completo.

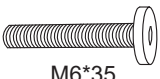



L008		x1	C		x2	D		x2	E		x1
				M6*35							

PASO 04: Del mismo modo que en el paso anterior, fije el reposabrazos izquierdo (L007) a la pata izquierda (L011) de la silla con tornillos.

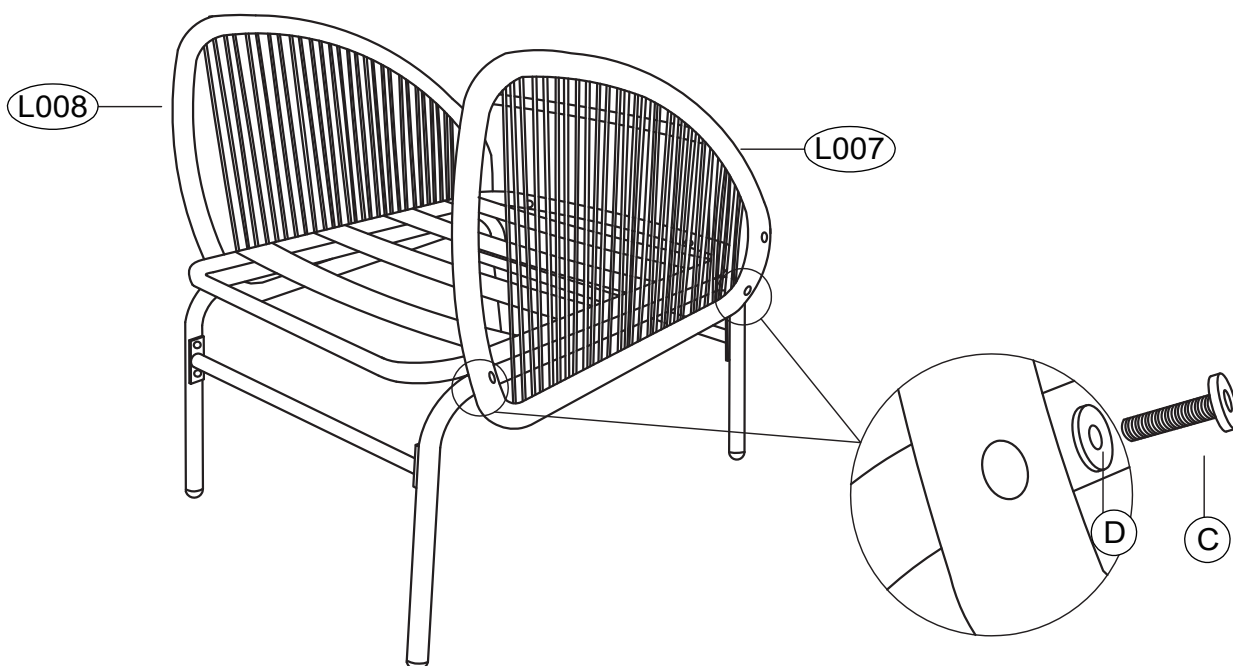
NOTA: No apriete los tornillos completamente.

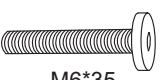





L008		x1	C		x2	D		x2	E		x1
				M6*35							

Pasos de instalación

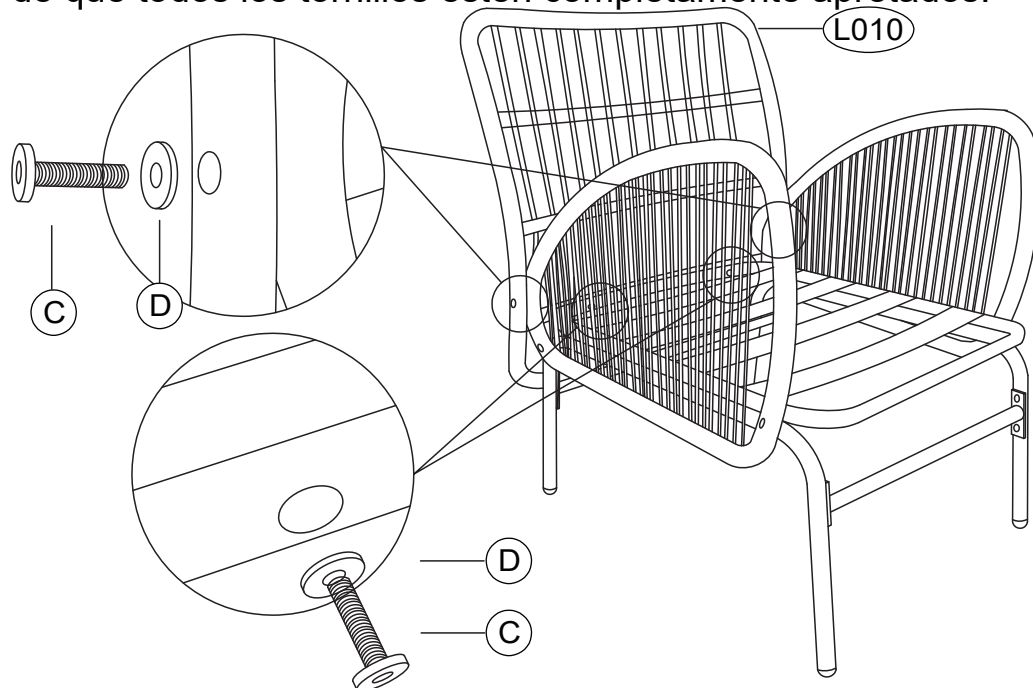
PASO 05: Fije el respaldo del asiento (L010) a los reposabrazos izquierdo y derecho y a la sección trasera del bastidor del asiento con tornillos.



NOTA: Asegúrese de que todos los tornillos estén completamente apretados.

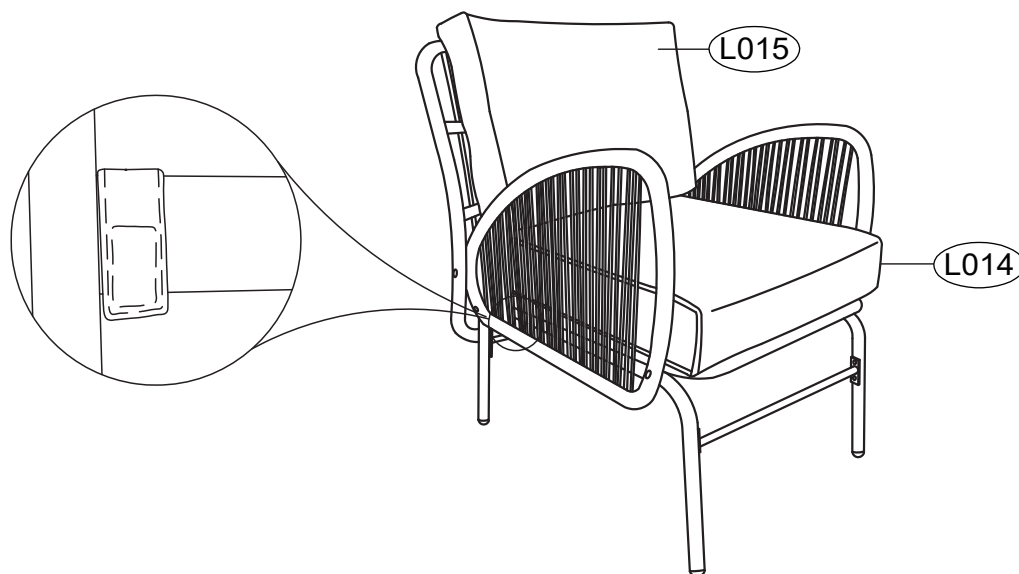

L010		x1	C		x4	D		x4	E		x1
				M6*35							

PASO 06: Coloque el cojín del asiento (L014) y el cojín del respaldo (L015) en la silla recién montada. Fije el cojín del asiento (L014) al marco metálico utilizando los cierres de velcro situados en la parte inferior del cojín.



L014		x2	L015		x2
------	---	----	------	---	----

Set di 3 sedie a sdraio con corda

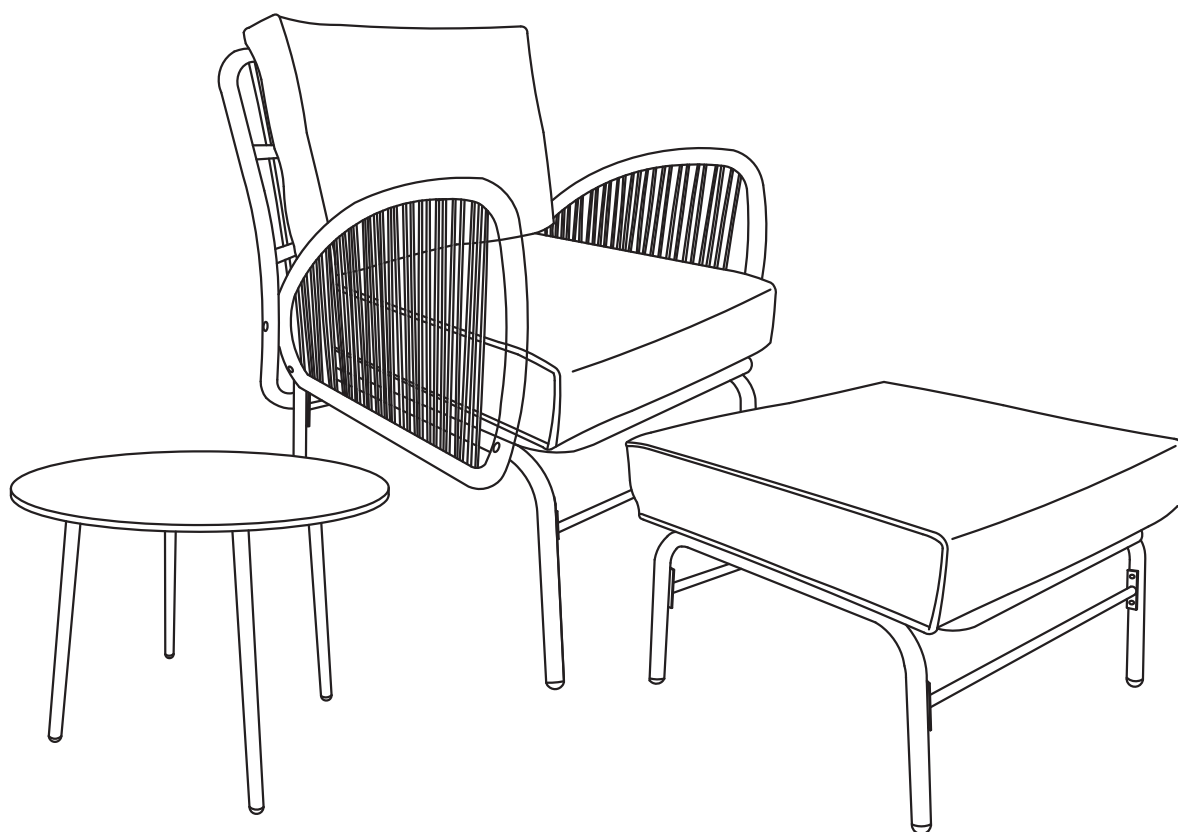

IMPORTANTE

LEGGERE PRIMA DI INIZIARE IL MONTAGGIO

Seguire le istruzioni contenute nel presente manuale d'uso per garantire il corretto montaggio e la corretta manutenzione del prodotto.

Set di 3 sedie a sdraio con corda

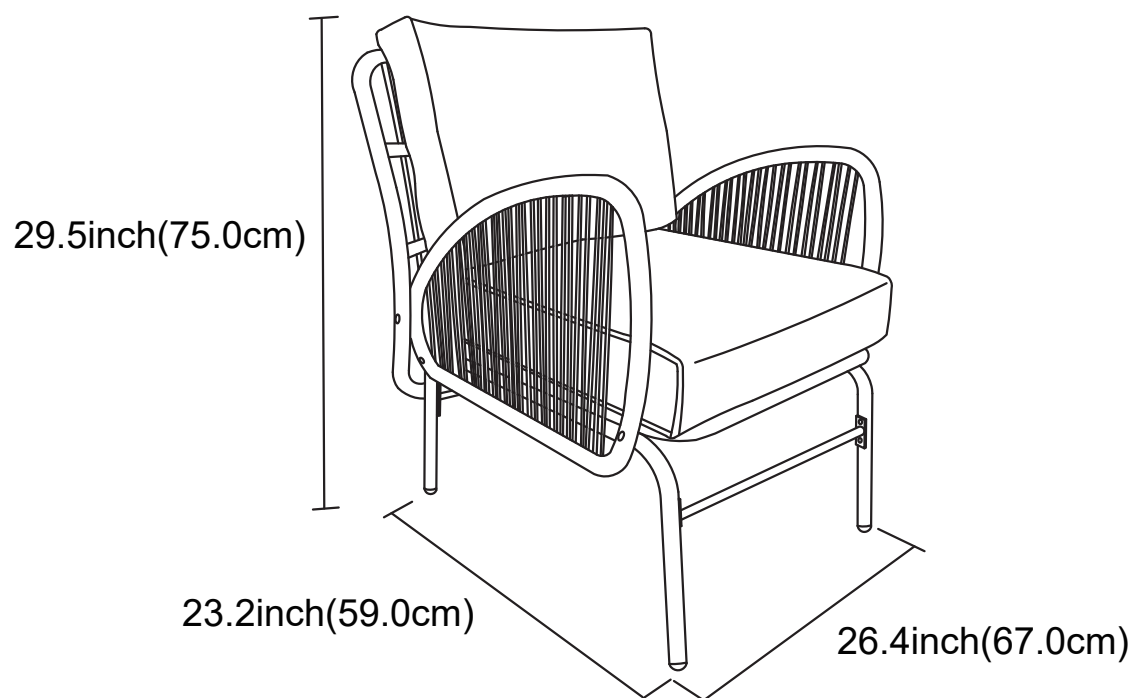
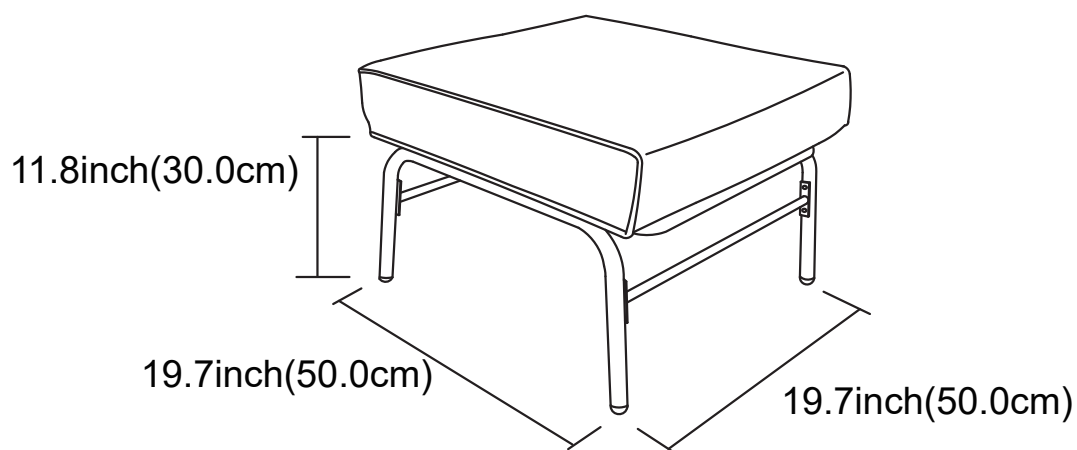

Catalogo

Specifiche.....	01
Catalogo.....	02
Avviso.....	03
Elenco dei componenti e delle viti.....	04
Come assemblare il tavolino.....	05
Come assemblare il poggiapiedi.....	06
Come assemblare la sedia.....	08







Prima di iniziare

Le istruzioni sono fornite in questo manuale e contengono tutte le informazioni necessarie per il vostro prodotto.

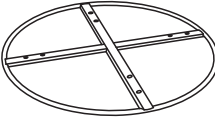

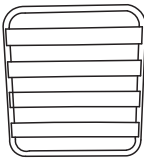
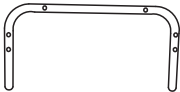

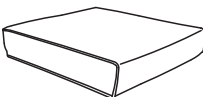
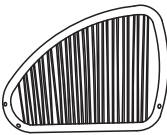
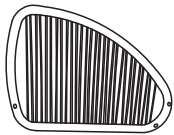
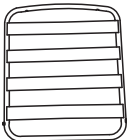
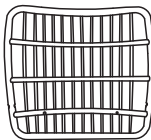
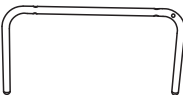
Leggete tutte le istruzioni prima di iniziare e durante il montaggio seguite attentamente la sequenza dei passaggi per ottenere risultati corretti.

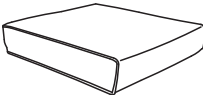
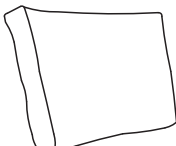
1. Tutti i componenti sono contenuti all'interno del cartone. Separare il contenuto del cartone in base al numero di serie, controllando l'elenco dei componenti. Verificare di avere tutti i componenti necessari per il montaggio.
2. Familiarizzare con la ferramenta e i dispositivi di fissaggio per facilitarne l'uso durante il montaggio.
3. I primi passaggi mostrano come unire i componenti correlati per ottenere sottogruppi più grandi da utilizzare in seguito.
4. Si noti che sono stati forniti elementi di fissaggio aggiuntivi per comodità.
5. Se si dispone di un cacciavite elettrico, è possibile utilizzarlo al posto del cacciavite in dotazione. Un cacciavite elettrico può aiutare a ridurre i tempi di assemblaggio.



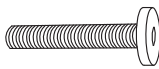

Elenco dei componenti

<p>L001</p> 	<p>L002</p> 	<p>L003</p> 	<p>L004</p> 
<p>1PC</p>	<p>4PCS</p>	<p>1PC</p>	<p>2PCS</p>
<p>L005</p> 	<p>L006</p> 	<p>L007</p> 	<p>L008</p> 
<p>2PCS</p>	<p>1PC</p>	<p>1PC</p>	<p>1PC</p>
<p>L009</p> 	<p>L010</p> 	<p>L011</p> 	<p>L012</p> 
<p>1PC</p>	<p>1PC</p>	<p>1PC</p>	<p>1PC</p>
<p>L013</p> 	<p>L014</p> 	<p>L015</p> 	
<p>2PCS</p>	<p>1PC</p>	<p>1PC</p>	

Set di viti

<p>A</p>  <p>M6*12</p>	<p>B</p>  <p>M6*15</p>	<p>C</p>  <p>M6*35</p>	<p>D</p>  <p>M6</p>	<p>E</p>  <p>4*4</p>
<p>8PCS</p>	<p>16PCS</p>	<p>16PCS</p>	<p>40PCS</p>	<p>1PC</p>

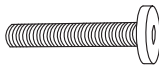
Extra (set di viti)

<p>A</p>  <p>M6*12</p>	<p>B</p>  <p>M6*15</p>	<p>C</p>  <p>M6*35</p>	<p>D</p>  <p>M6</p>	
<p>1PC</p>	<p>2PCS</p>	<p>2PCS</p>	<p>5PCS</p>	

Come assemblare il tavolino

FASE 01: Capovolgere il piano del tavolo (L001) in modo che la parte inferiore sia rivolta verso l'alto, quindi fissare le gambe del tavolo (L002) al piano utilizzando le viti.

NOTA: Quando si fissa ciascuna gamba, serrare entrambe le viti contemporaneamente. Infine, assicurarsi che tutte le viti siano completamente serrate.

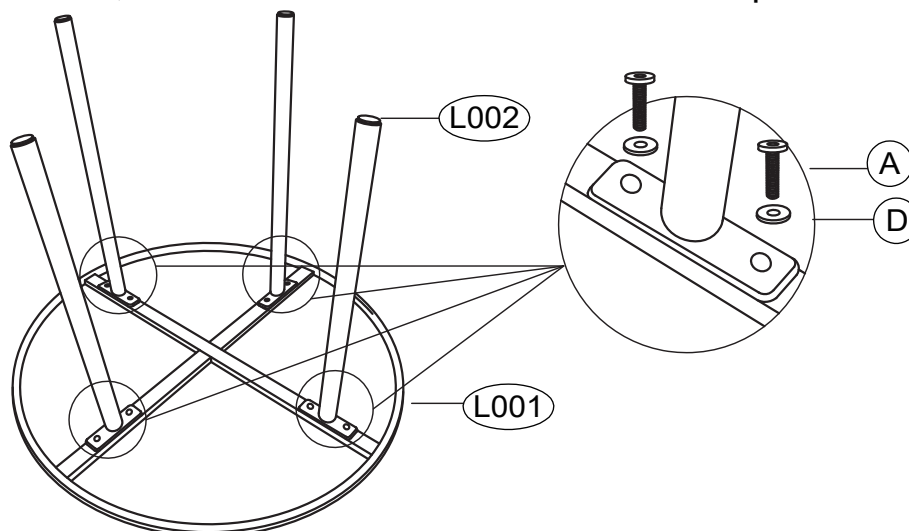

L001		x2	L002		x1	A		x8	D		x8	E		x1
							M6*12							

FASE 02: Riportare il piano del tavolo nella posizione originale e ruotare i piedini regolabili per stabilizzare il tavolo.

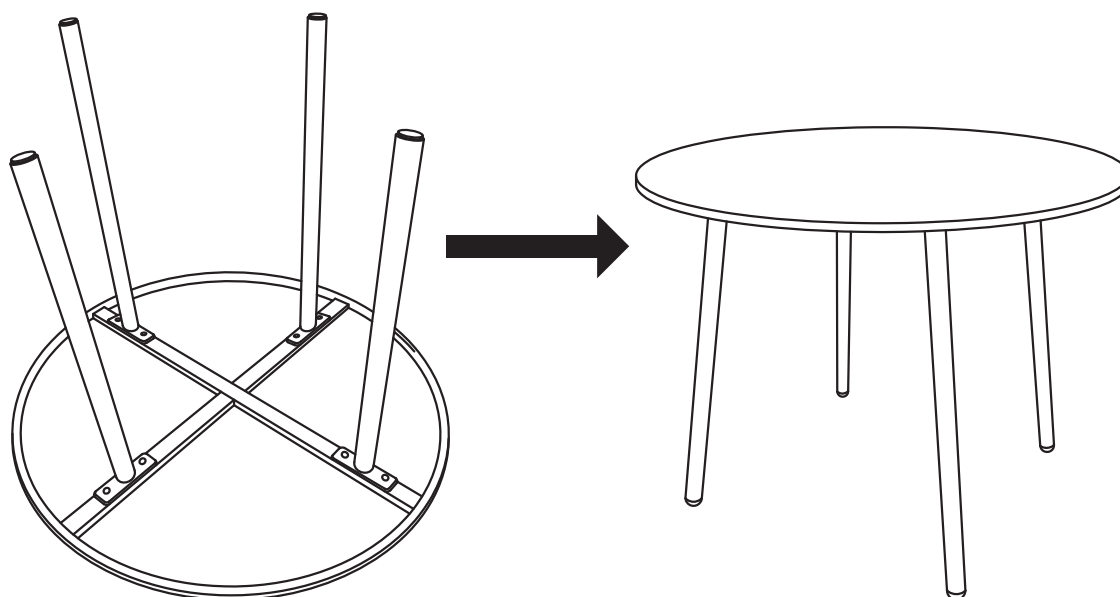

Come montare il poggiapiedi

FASE 01: Capovolgere il telaio del poggiapiedi (L003) in modo che il lato posteriore sia rivolto verso l'alto. Fissare la gamba del poggiapiedi (L004) ai lati sinistro e destro del telaio del poggiapiedi (L003) utilizzando le viti.

NOTA: Non serrare completamente le viti.

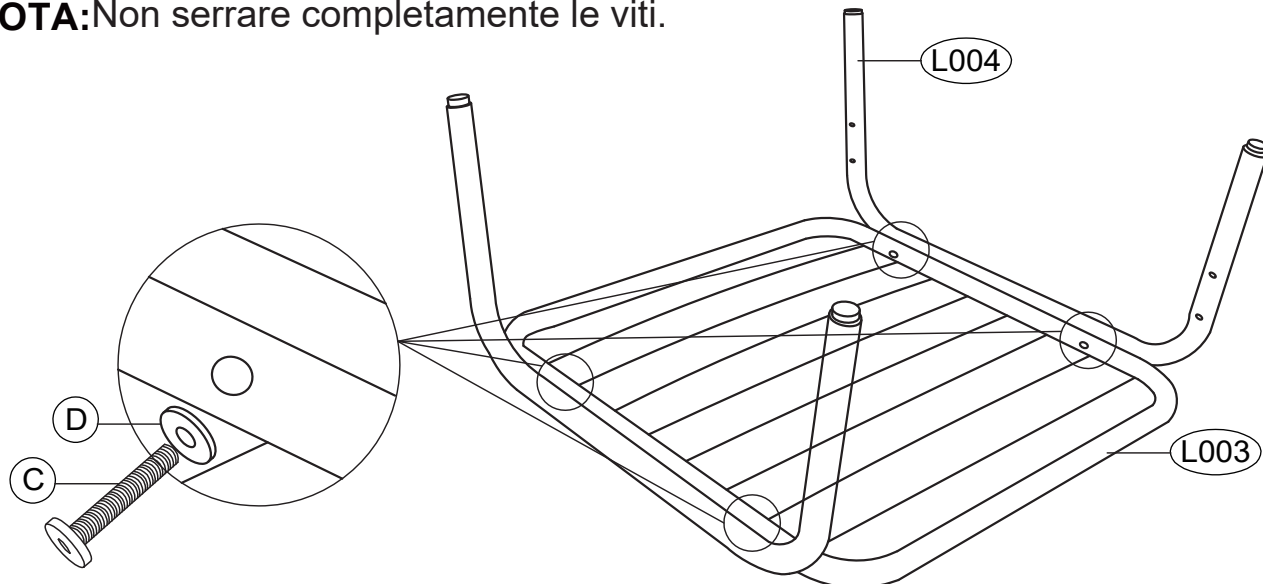

L003		x1	L004		x2	C		M6*35	x4	D		x4	E		x1
------	--	----	------	--	----	---	--	-------	----	---	--	----	---	--	----

FASE 02: Fissare le due aste di supporto del poggiapiedi (L005) al centro delle due gambe appena installate, fissandole rispettivamente alla parte anteriore e posteriore di ciascuna gamba.

NOTA: Assicurarsi che tutte le viti siano completamente serrate.

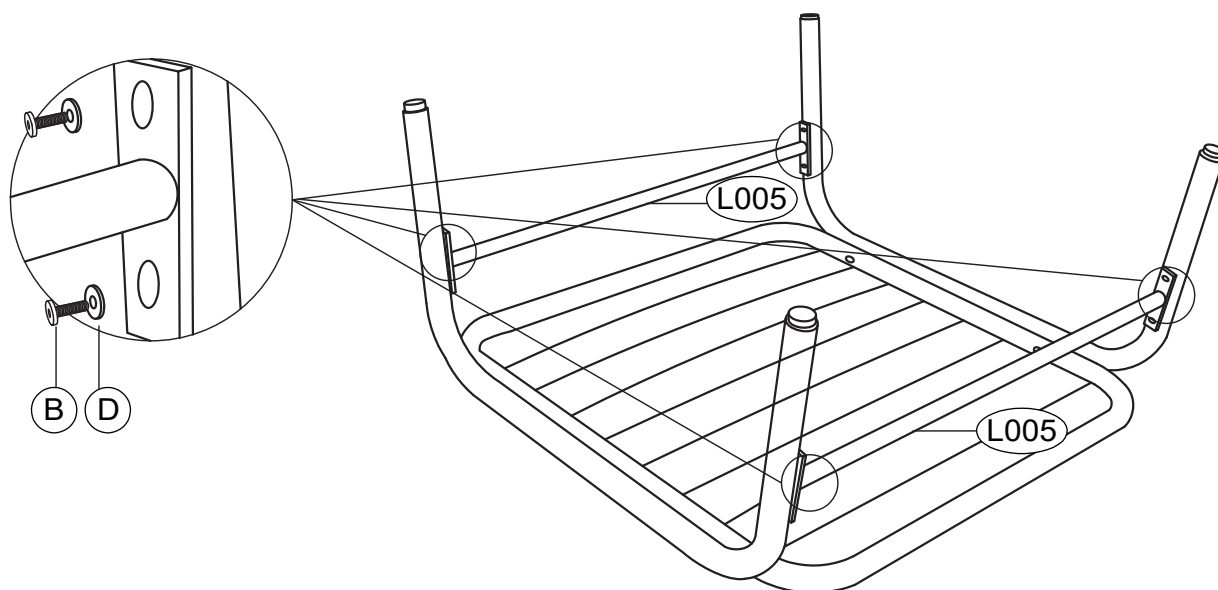

L005		x2	B		x8	D		x8	E		x1
------	--	----	---	--	----	---	--	----	---	--	----

FASE 03: Riportare il poggiatesta nella posizione originale. Posizionare il cuscino del poggiatesta (L006) sopra il poggiatesta appena installato, fissandolo al telaio metallico utilizzando le chiusure in velcro presenti sul lato inferiore del cuscino.

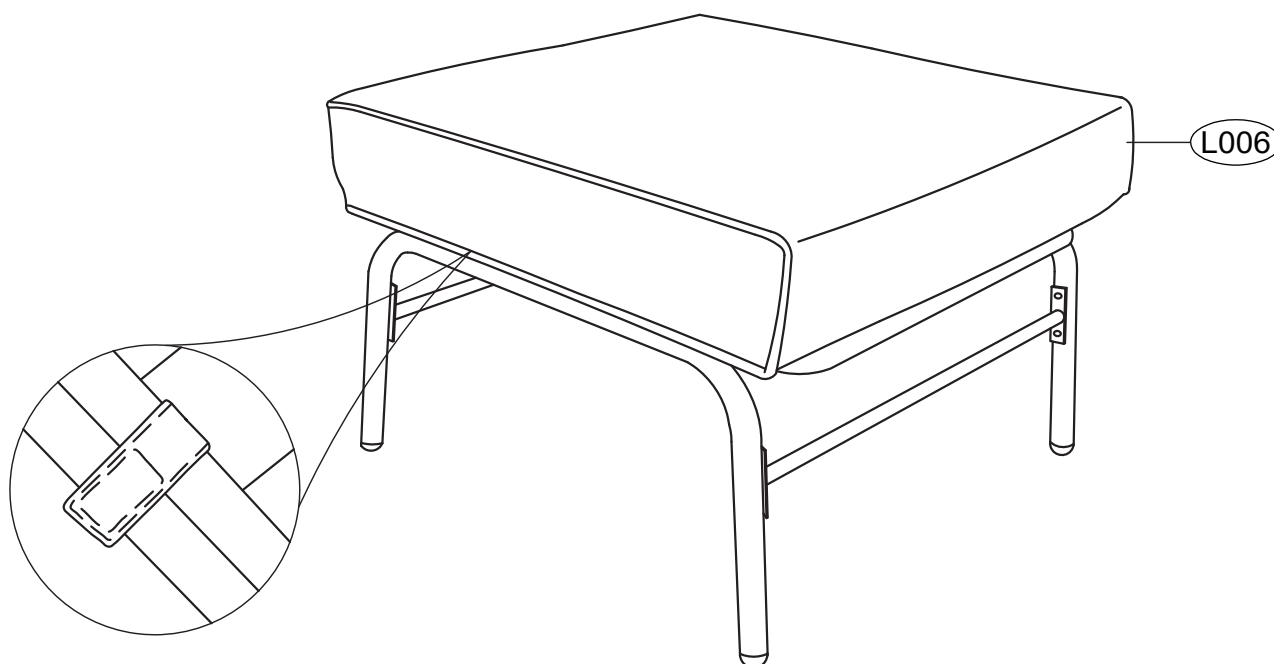

L006

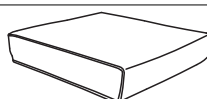

x1





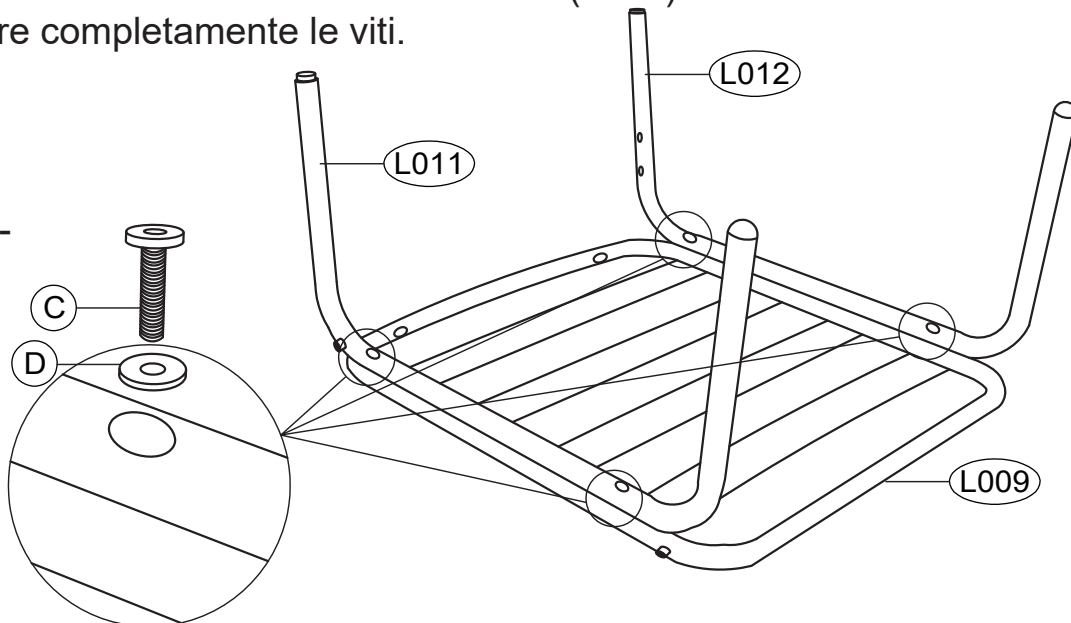

Come assemblare la sedia

FASE 01: Capovolgere il telaio del sedile (L009) in modo che il lato posteriore sia rivolto verso l'alto. Fissare la gamba sinistra (L011) e la gamba destra (L012) su entrambi i lati del telaio del sedile (L009) utilizzando le viti.

NOTA: Non serrare completamente le viti.

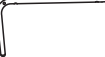
Le gambe della sedia dotate di piedini regolabili sono quelle posteriori, che devono essere posizionate più vicino al lato del telaio del sedile dotato di fori.





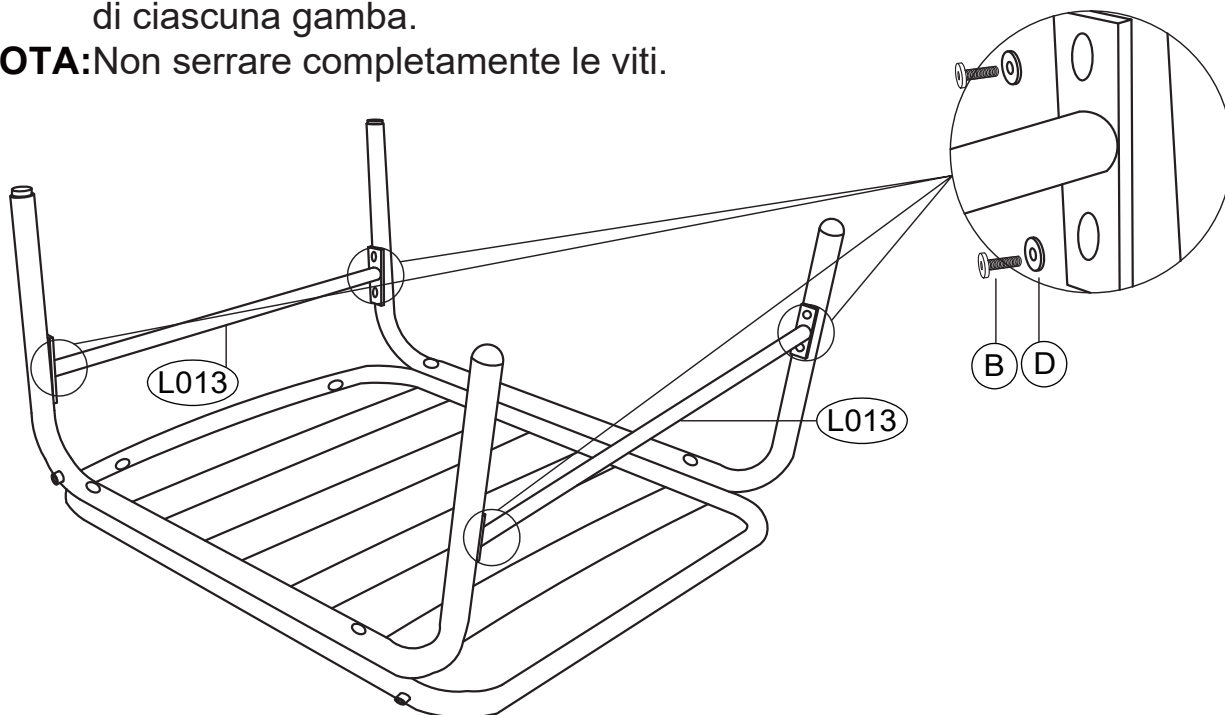

L009	 x1	L011	 x1	L012	 x1	C	 x4	D	 x4	E	 x1
						M6*35					

FASE 02: Fissare le due aste di supporto del sedile (L013) al centro delle gambe sinistra e destra appena installate, fissandole ai lati anteriore e posteriore di ciascuna gamba.

NOTA: Non serrare completamente le viti.





L013	 x1	B	 x8	D	 x8	E	 x1
			M6*15				

FASE 03: Riportare il sedile in posizione. Allineare i fori delle viti anteriori e posteriori sulla sezione inferiore del bracciolo destro (L008) con i corrispondenti fori delle viti anteriori e posteriori sul lato esterno della gamba destra (L012) del sedile appena installato, quindi fissarli con le viti.

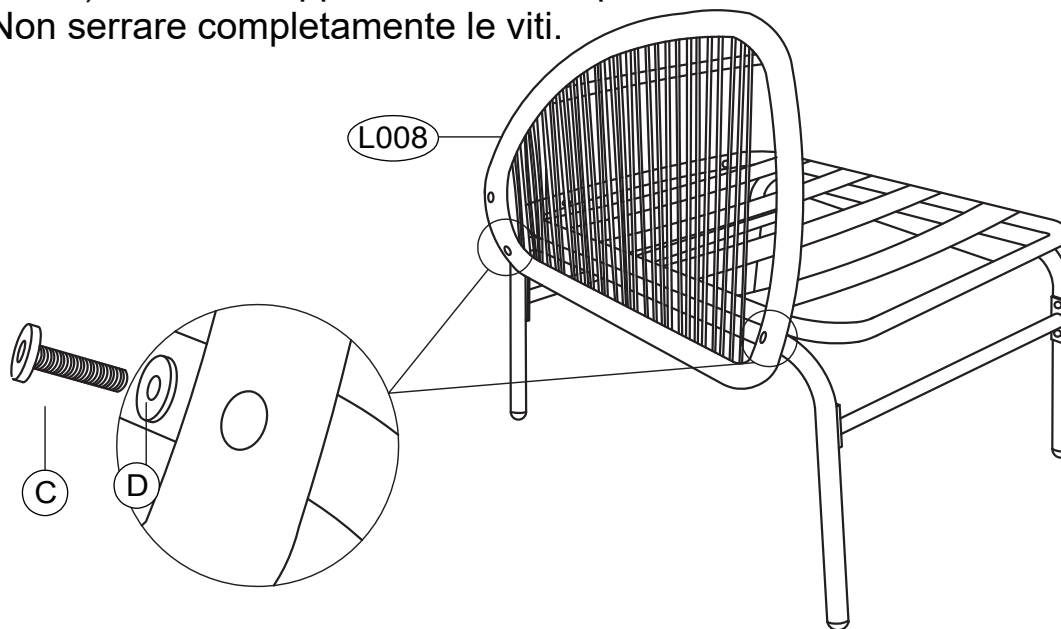
NOTA: Non serrare completamente le viti.

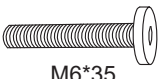



L008		x1	C		x2	D		x2	E		x1
				M6*35							

FASE 04: Come nel passaggio precedente, fissare il bracciolo sinistro (L007) alla gamba sinistra (L011) della sedia utilizzando le viti.

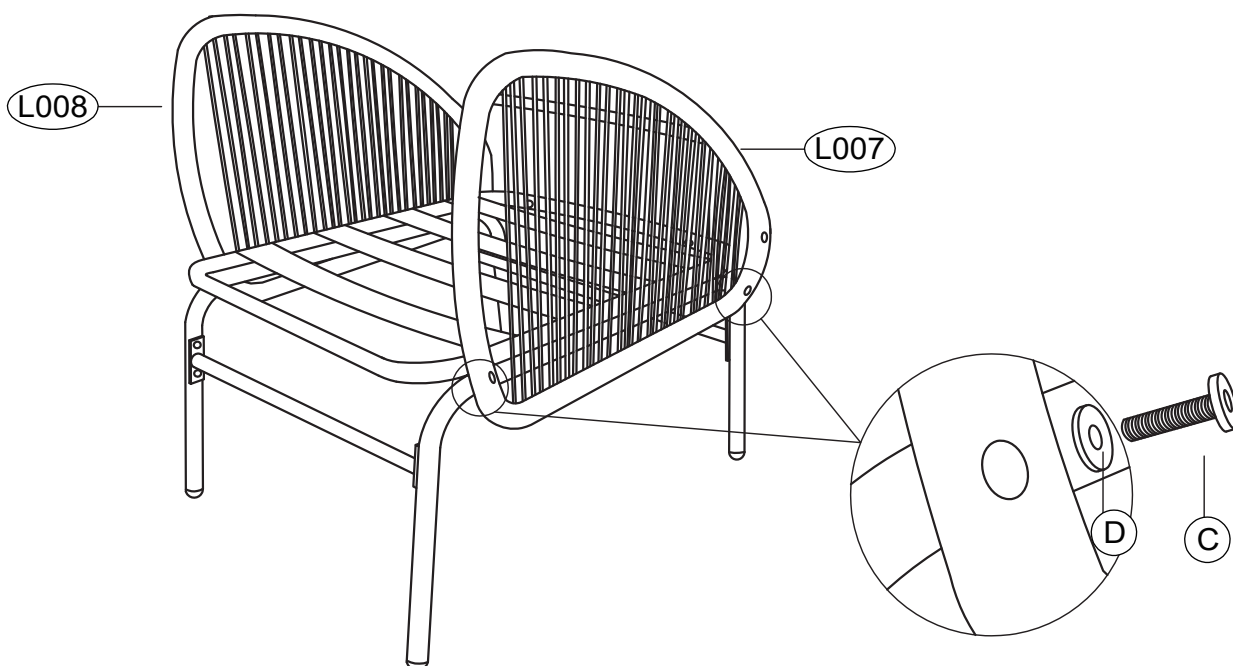
NOTA: Non serrare completamente le viti.

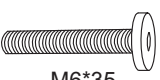



L008		x1	C		x2	D		x2	E		x1
				M6*35							

FASE 05: Fissare lo schienale del sedile (L010) ai braccioli sinistro e destro e alla sezione posteriore del telaio del sedile utilizzando le viti.

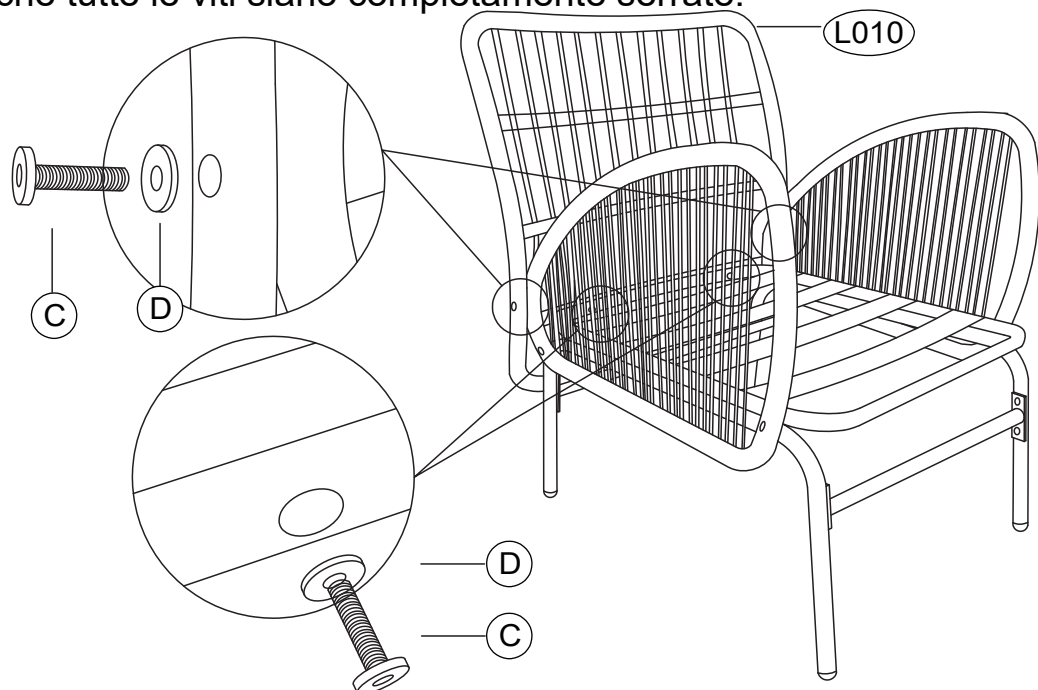

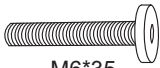
NOTA: Assicurarsi che tutte le viti siano completamente serrate.

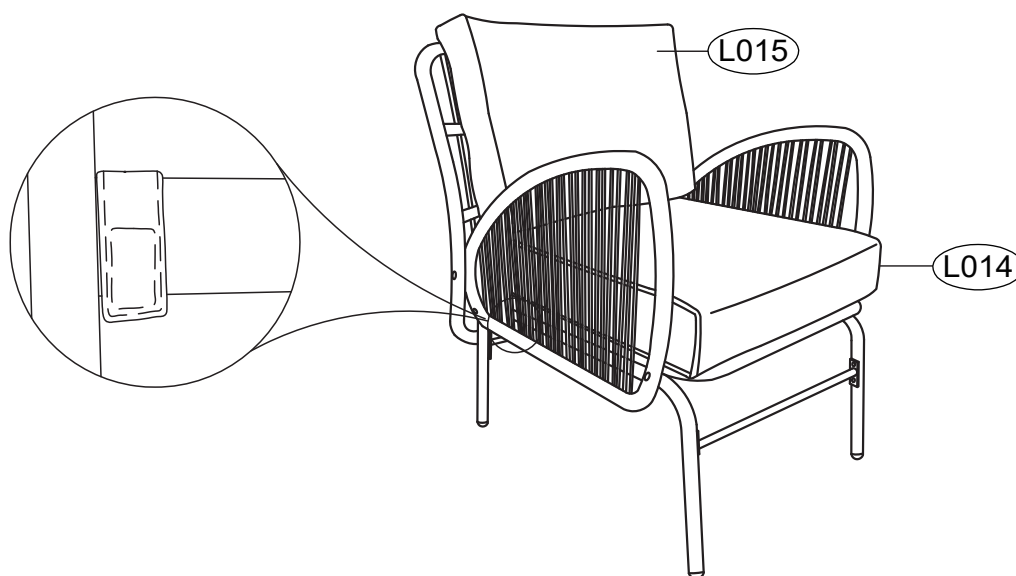

L010		x1	C		x4	D		x4	E		x1
				M6*35							

FASE 06: Posizionare il cuscino del sedile (L014) e il cuscino dello schienale (L015) sulla sedia appena assemblata. Fissare il cuscino del sedile (L014) al telaio metallico utilizzando le chiusure in velcro presenti sul lato inferiore del cuscino.



L014		x2	L015		x2
------	---	----	------	---	----