

Instruction Manual

User Guide

Make life better

Warm tips: We are proud of high-quality products and satisfactory service, but the goods may encounter special circumstances during transportation, if you receive the goods with missing or damaged parts, please take photos and contact our customer service before returning the goods , we will customize a solution that satisfies you, thank you.

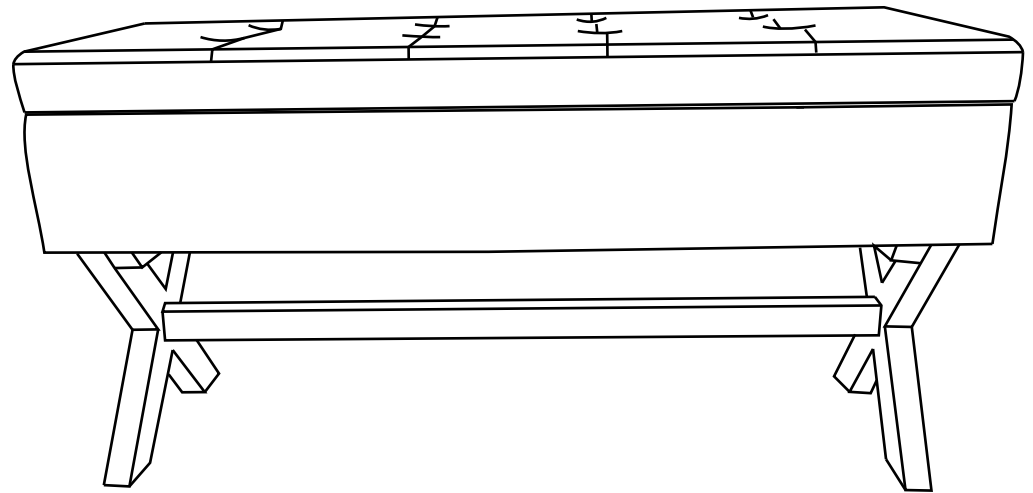



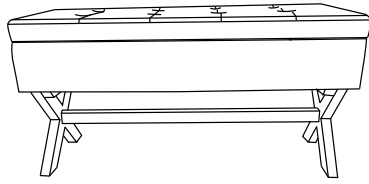

STORAGE ENTRYWAY BENCH

Instruction

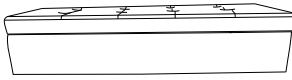
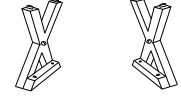
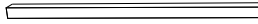
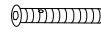

◀ STORAGE ENTRYWAY BENCH

▼ PARTS LIST

NO	DESCRIPTION		QTY
A	Top Frame		1
B	Leg		2
C	Rod		1
D	Screw	$\Phi 5/16 \times 2-3/8 \text{ "L}$ 	6
E	Black Flat Washer	$\Phi 5/16 \text{ "mm}$ 	2
F	Flat Washer	$\Phi 5/16 \times 22 \text{ mm}$ 	4
G	Lock Washer	$\Phi 5/16 \text{ mm}$ 	4
H	Allen Wrench	$\Phi 5 \text{ mm}$ 	1

Note:

1. During the assembly of the two components, if there are multiple screws that need to be installed, you can first align all the screws with the hole position and manually turn a few turns to fix the position, and then tighten them all with a wrench.

2. The Flat Washer and Lock Washer must be installed to prevent the screw from loosening and damaging the connection part.

Installation Method

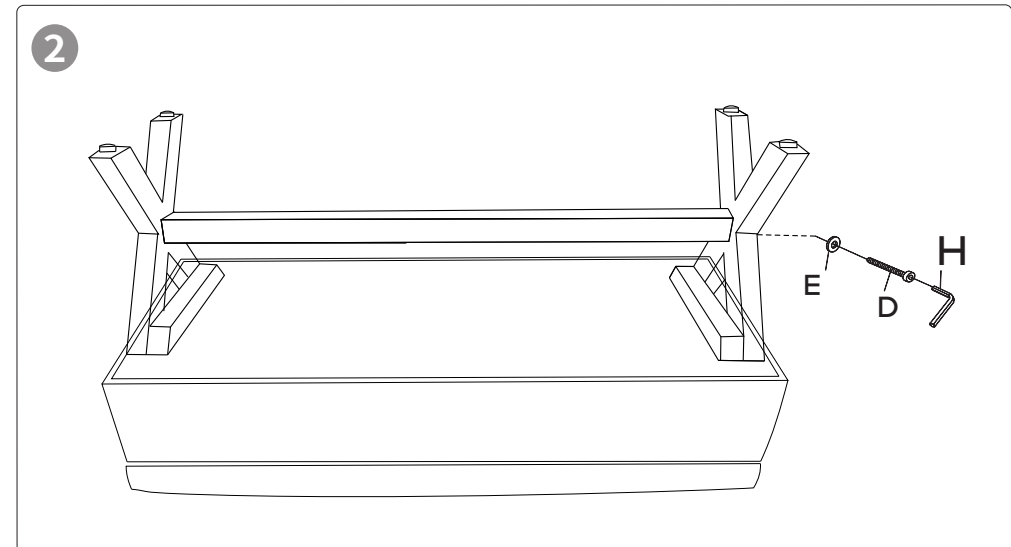
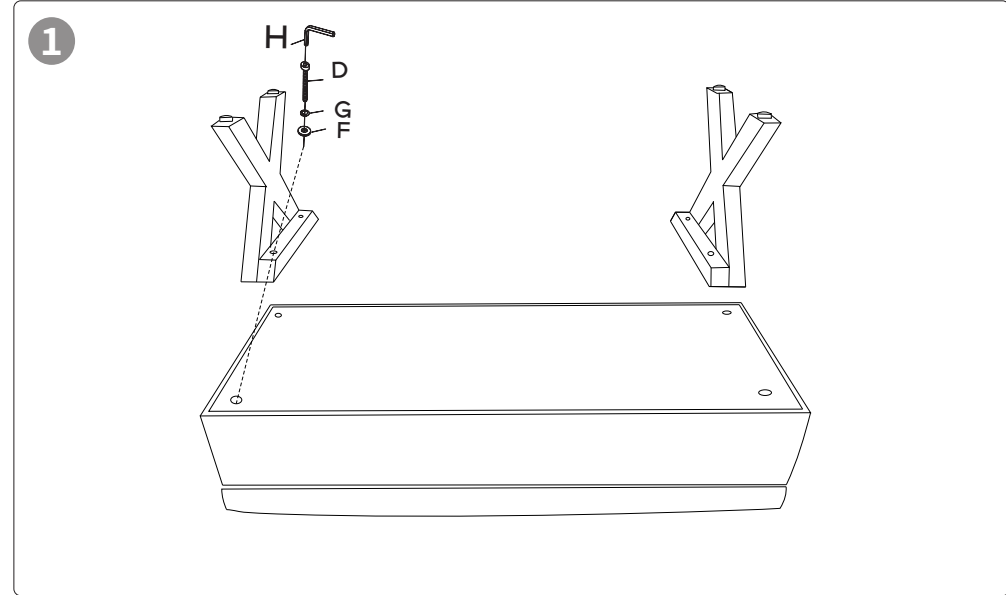

1. Open the top lid of the product, and take out the product legs and parts; First install the legs of B to A, align them with the holes, and the side with the big round hole faces inwards, as the picture shows, connect D, G, F. Note: Do not tighten the screws at this place, repeat this step for the next three screws;

2. Align C with the round holes in the middle of the two X-shaped legs, connect the black washer E to the screw D, and tighten both sides; Tighten the 4 screws mentioned in Step 1, and the installation is complete.