

ASSEMBLY INSTRUCTION

024-916 BARDEN ROUND TABLE

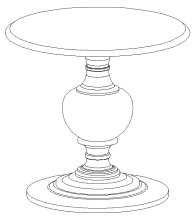

High 25"

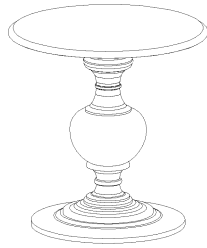



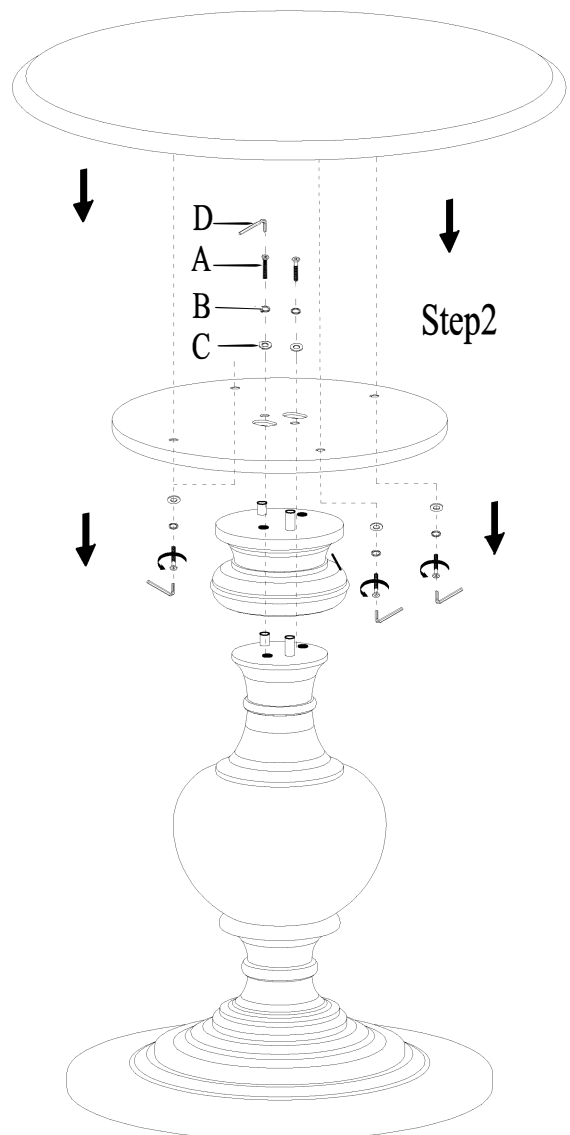
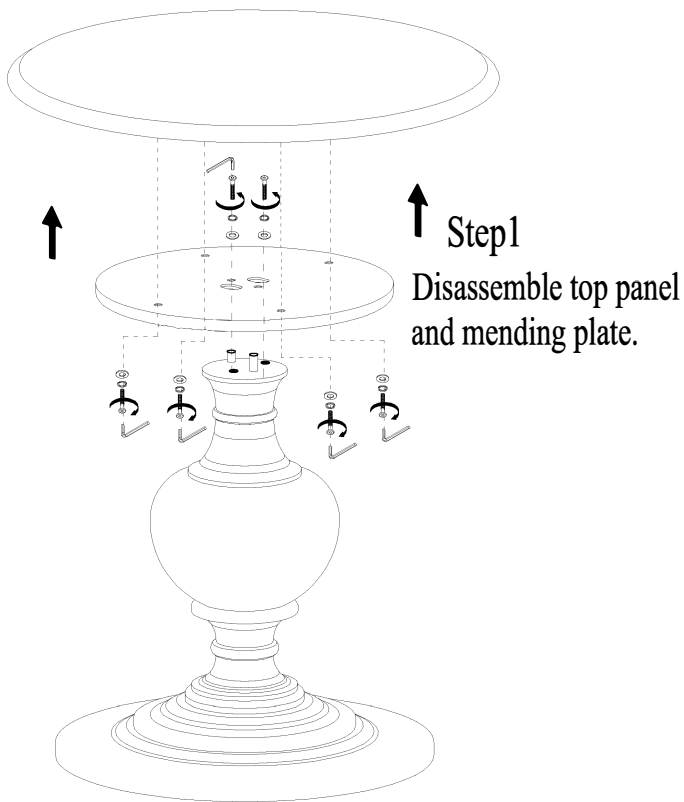

Assembly is now completed.
High 28-1/4"

IMPORTANT NOTES :

- . Place all wooden parts on a clean and smooth surface such as a rug or carpet to prevent the parts from being scratched.
- . Check to be sure that you have all parts and hardware.
- . Remove all wrapping materials, including staples and packing straps before you start to assemble.
- . Do not tighten all screws and bolts until completely assembled.
- . Keep all hardware out of the reach of children.



NO.	Dimension	Shape	Quantity
A	Flat Washer #5/16"*19		2pcs
B	Lock Washer Ø5/16"		2pcs
C	Bolt 5/16*125mm		2pcs
D	Allen Key 4mm		1pc