

COCKTAIL

Assembly Instructions

Top supports up to lb.

Shelf supports up to lb.

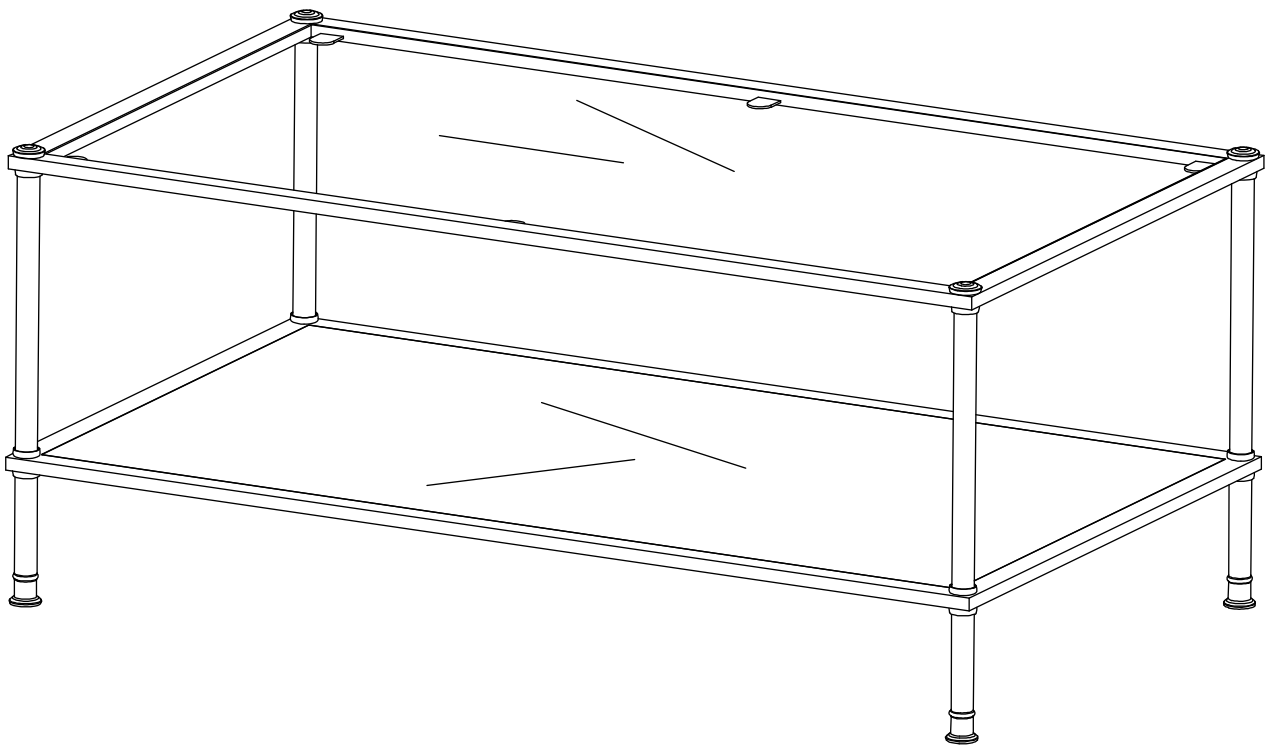

COCKTAIL

Parts List

Please review all parts and hardware before disposing of any packaging.

Call Customer Service if missing hardware.

Carefully study the diagrams below.

You may receive extra hardware with your unit.

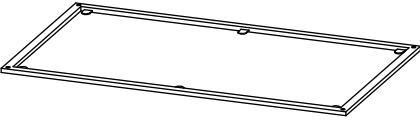
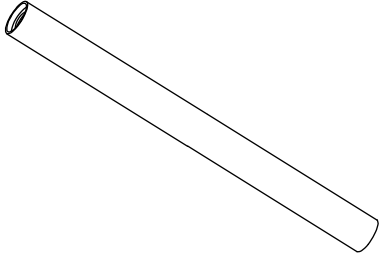
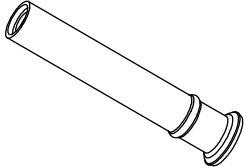
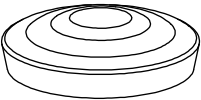
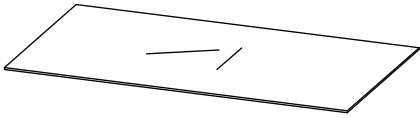
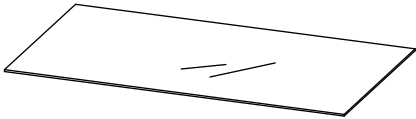
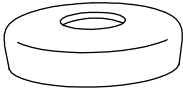
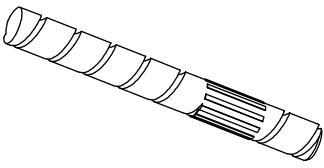
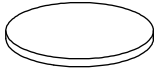
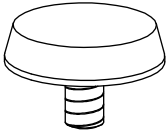
<p>1 2PCS</p>  <p>Frames</p>	<p>2 4PCS</p>  <p>Supports</p>	<p>3 4PCS</p>  <p>Legs</p>
<p>4 4PCS</p>  <p>Metal Caps</p>	<p>6 1PC</p>  <p>Glass Top</p>	<p>7 1PC</p>  <p>Mirror Shelf</p>
<p>5 12PCS</p>  <p>Metal Washers</p>	<p>A 8PCS</p>  <p>Bolts 5/16"x1-3/4"</p>	<p>B 12PCS</p>  <p>Glass Pads</p>
		<p>C 4PCS</p>  <p>Levelers</p>

Care and Cleaning Instructions:

Before using, wipe with a clean, dry cloth.
Avoid rubbing or scratching the surface with rough or abrasive objects.

For replacement parts or questions, please call customer service.

Assembly Tool Required
No.2 Phillips Screwdriver

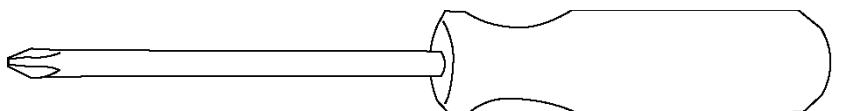

COCKTAIL

Assembly Instructions

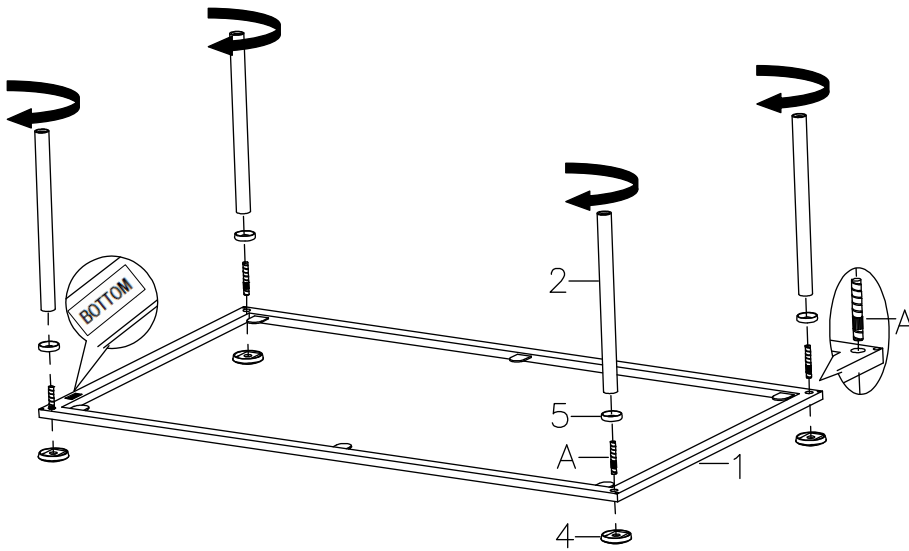

Figure 1

Step 1:

Unit assembly should begin with parts turned upside down for Step 1.

Attach Metal Caps (4), Metal Washers (5) and Supports (2) to Top Frame (1) connecting with Screws (A) as shown.

Please make sure the labels reading **BOTTOM** under Frames (1) are facing upwards.

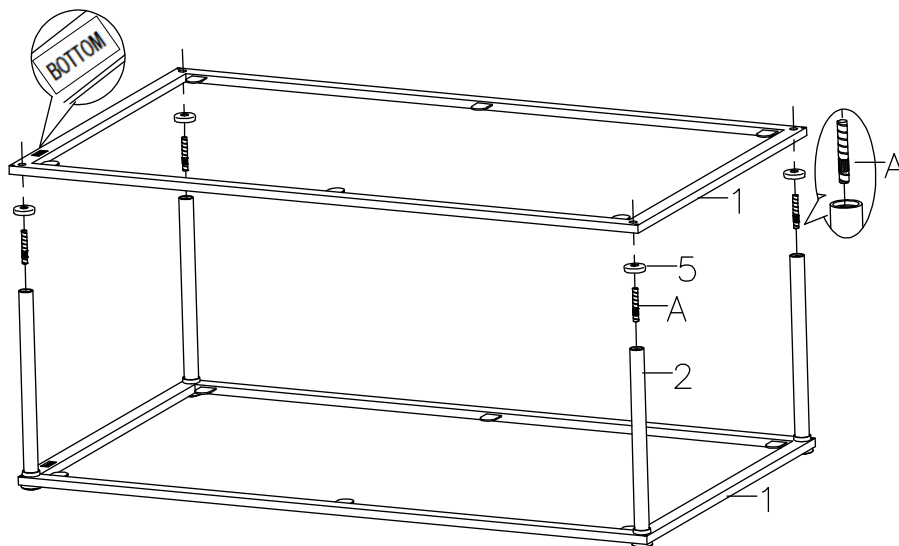
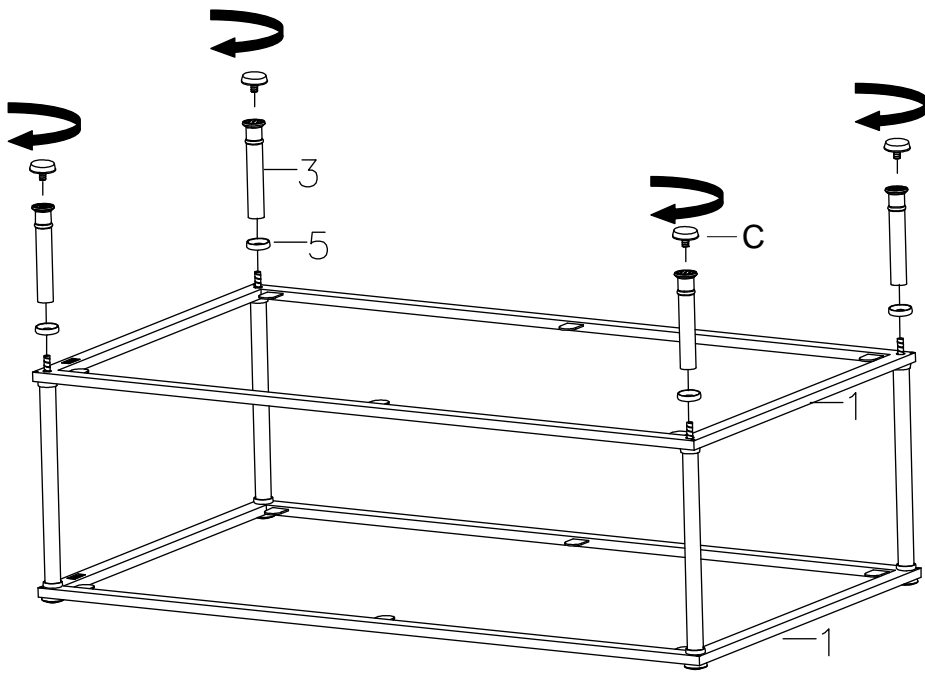

Figure 2

Step 2:

Attach Screws (A) to Supports (2), then, attach Metal Washers (5) and Shelf Frame (1) to Supports (2) connecting with Screws (A) as shown.



Step 3:

Attach Metal Washers **(5)** to Screws **(A)**, and then attach Legs **(3)** to Metal Washers **(5)**.

Clockwise to tighten the parts.

Screw Levelers **(C)** to Legs **(3)**.

Figure 3

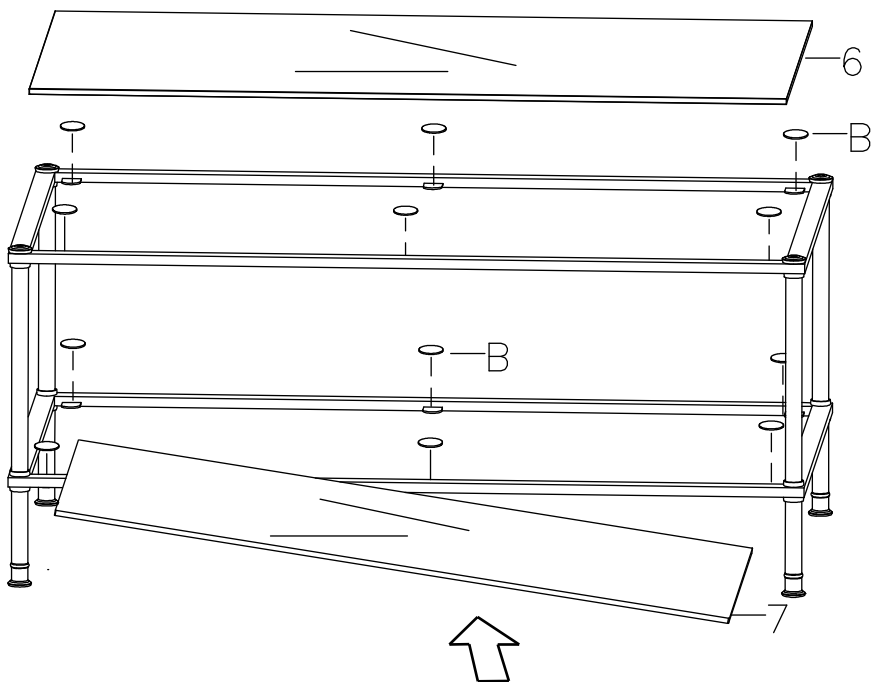

Step 4:

Attach Glass Pads **(B)** to the brackets on Frames **(1)**.

Place Glass Top **(6)** to Top Frame **(1)** and insert Mirror Shelf **(7)** to Shelf Frame **(1)** as shown.

Your Cocktail Table assembly is now complete.

Figure 4

Parts Replacement Form

Customer Information

Name _____

Address _____

City/State/Zip Code _____

Phone Number _____

Please indicate where you purchased this item: Store/Website/Catalog

Please indicate color/size/style number:

Style No	Parts Letter	Parts Description	Quantity Needed
----------	--------------	-------------------	-----------------
